

# ASEL



Position controller for RCA series  
Program controller

## Type List

Program controller capable of operating RCA series actuator. Various control functions are combined into a single unit.

Type	C	
Name	Program mode	Positioner mode
External view		
Description	Both actuator operation and communication with external equipment can be handled by a single controller. When two axes are connected, arc interpolation and path operation can be performed.	Up to 1,500 positioning points are supported. Push-motion operation and teaching operation are also possible.
Number of position points	1500	

## Model

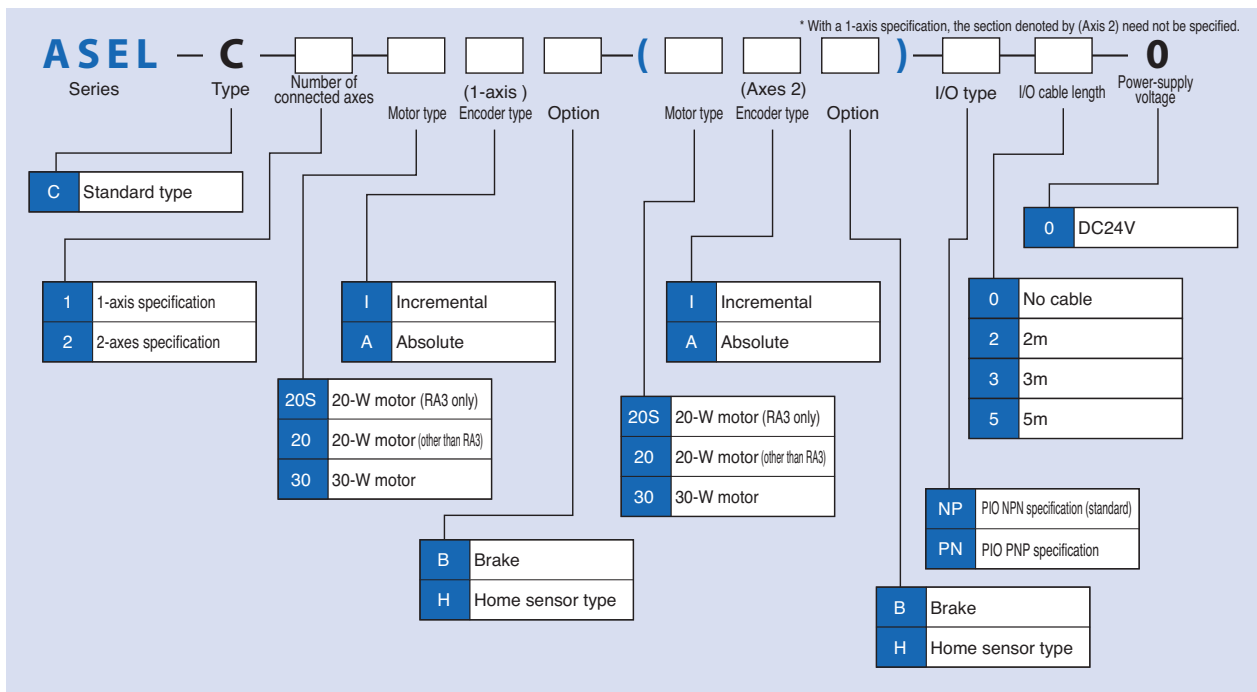

System Configuration

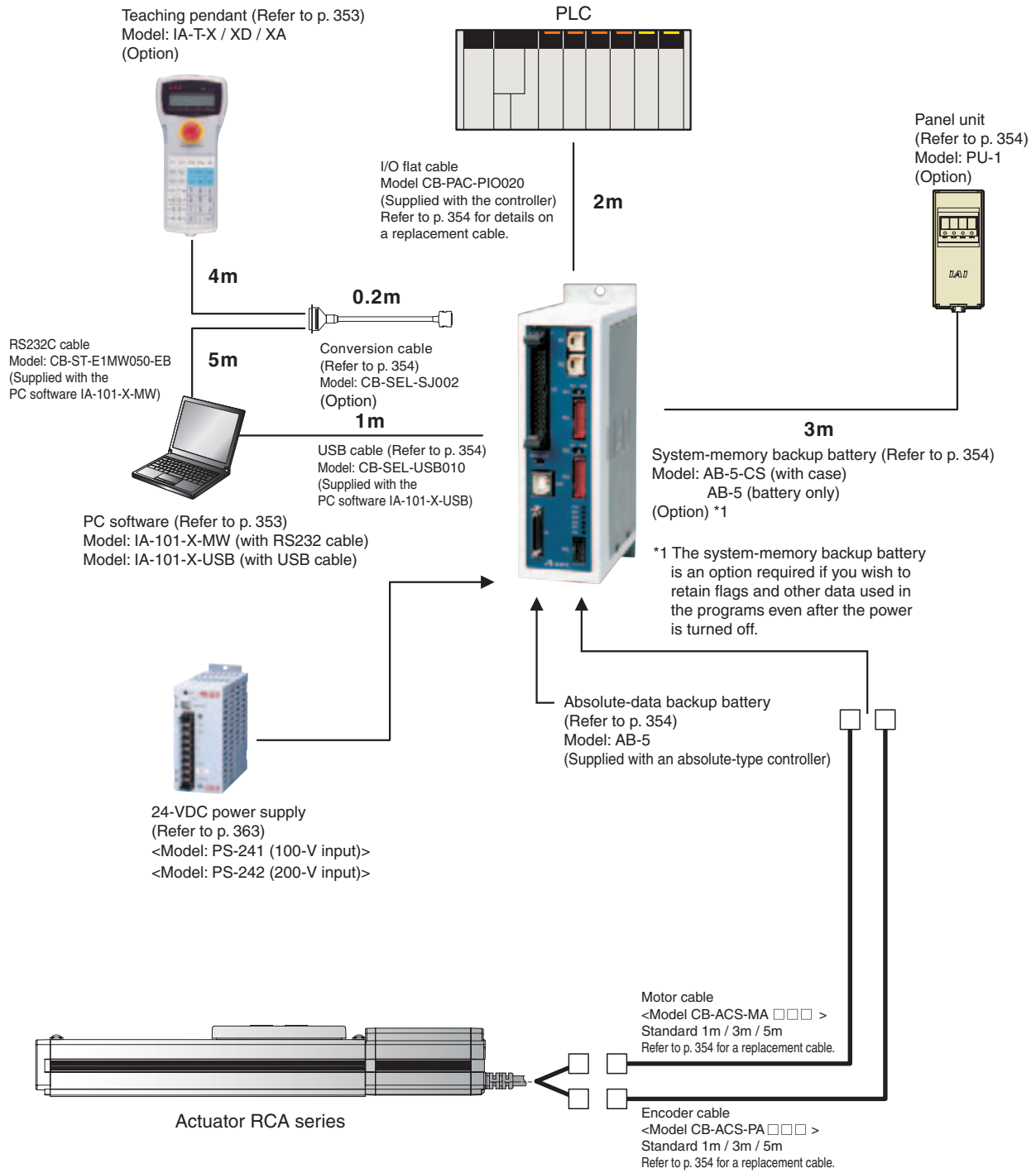

- Controller - Integrated type
- Slider Type
- Rod Type
- Arm / Flat Type
- Gripper / Rotary Type
- Cleanroom Type
- Splash Proof Type
- Controller
- Controller Models
- Gateway unit
- PS-24
- ERC2
- PCON
- ACON
- SCON
- PSEL
- ASEL
- SSEL
- XSEL

**I/O Specifications**

■ **Input Part External input specifications**

Item	Specification
Input voltage	DC24V ± 10%
Input current	7mA/1circuit
ON/OFF voltage	ON voltage (Min.) NPN:DC16V/PNP:DC8V OFF voltage (Max.) NPN:DC5V/PNP:DC19V
Insulation method	Photocoupler

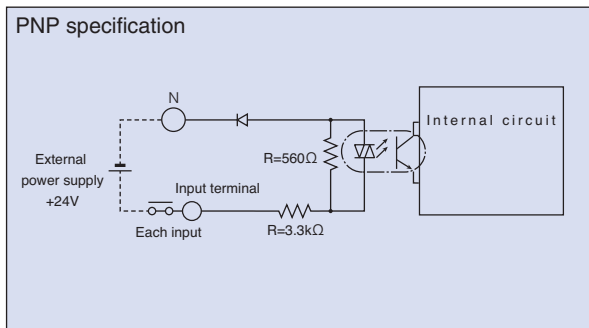
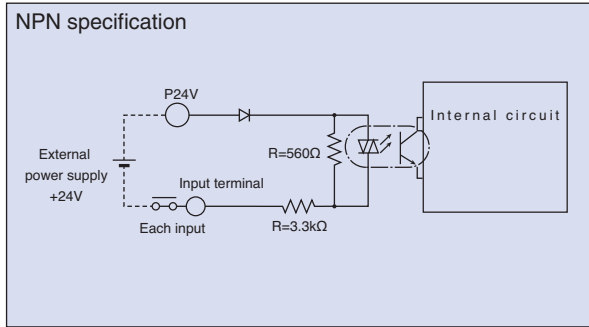

■ **Output Part External output specifications.**

Item	Specification
Load voltage	DC24V
Max. load current	1mA/point 400mA/8point total
Leak current	Max. 0.1mA/1point
Insulation method	Photocoupler

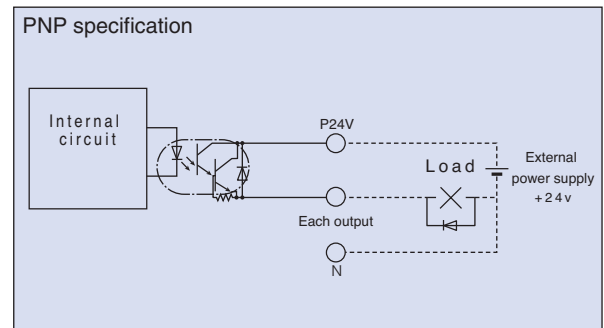
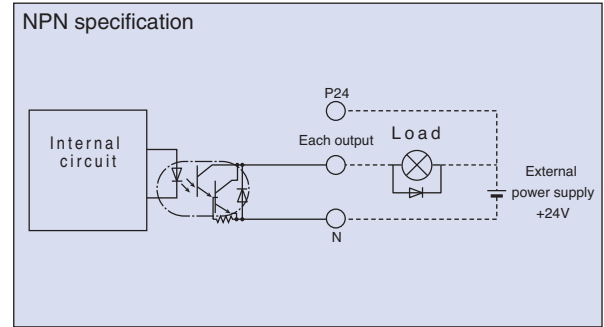

**Explanation of I/O Functions**

The ASEL controller lets you select either the “program mode” in which the actuator is operated by programs input to the controller, or the “positioner mode” in which the actuator moves to the positions specified by PLC signals received from the host. The positioner mode provides the following five input patterns each supporting different applications.

■ **Controller Functions by Type**

Operation mode		Features
Program mode		Various operations including linear/arc interpolation operation, path operation ideal for coating processes, etc., arch-motion operation and palletizing operation can be performed using the Super SEL language that lets you program complex control actions using simple commands.
Positioner mode	Standard mode	A basic operation mode in which a position number is specified and then a start signal is input to start operation. Push-motion operation and 2-axis linear interpolation operation are also supported.
	Product-type switchover mode	Multiple works of the same shape with slightly different hole positions can be handled using movement commands to the same position numbers by simply changing the product type number.
	2-axis independent mode	With a 2-axis controller, each axis can be commanded and operated separately.
	Teaching mode	The slider (rod) can be moved via an external signal to store the achieved position as position data.
	DS-S-C1 compatible mode	If you were using a DS-S-C1 controller before, you can replace it with a ASEL controller without having to change the host programs. * This mode does not ensure actuator compatibility.

- Controller - Integrated Type
- Slider Type
- Rod Type
- Arm / Flat Type
- Gripper / Rotary Type
- Cleanroom Type
- Splash Proof Type
- Controller**
- Controller Models
- Gateway unit
- PS-24
- ERC2
- PCON
- ACON
- SCON
- PSEL
- ASEL**
- SSEL
- XSEL

Explanation of I/O Functions

Program mode

Pin number	Category	Port number	Program mode	Function	Wiring diagram	
1A	P24		24-V input	Connect 24V.		
1B		016	Program No. 1 selection	These signals are used to select the program to be started. (BCD input using ports 016 to 022)		
2A		017	Program No. 2 selection			
2B		018	Program No. 4 selection			
3A		019	Program No. 8 selection			
3B		020	Program No. 10 selection			
4A		021	Program No. 20 selection			
4B		022	Program No. 40 selection			
5A		023	CPU reset			This signal is used to reset the system to create the same condition after power reconnection.
5B		000	Start			This signal is used to start the program selected by port Nos. 016 to 022.
6A		001	General-purpose input			These signals are used with a program command to wait for external input.
6B		002	General-purpose input			
7A		003	General-purpose input			
7B		004	General-purpose input			
8A		005	General-purpose input			
8B		006	General-purpose input			
9A		007	General-purpose input			
9B		008	General-purpose input			
10A		009	General-purpose input			
10B		010	General-purpose input			
11A		011	General-purpose input	These signals can be turned ON/OFF freely using program commands.		
11B		012	General-purpose input			
12A		013	General-purpose input			
12B		014	General-purpose input			
13A		015	General-purpose input			
13B		300	Alarm			This signal is output upon an alarm. (Contact B)
14A		301	Ready			This signal is output once the controller has started properly and entered a ready state.
14B		302	General-purpose output			These signals can be turned ON/OFF freely using program commands.
15A		303	General-purpose output			
15B		304	General-purpose output			
16A		305	General-purpose output			
16B		306	General-purpose output			
17A		307	General-purpose output	These signals can be turned ON/OFF freely using program commands.		
17B	N		0-V input			Connect 0V.

Positioner, Standard Mode

Pin number	Category	Port number	Positioner, standard mode	Function	Wiring diagram	
1A	P24		24-V input	Connect 24V.		
1B		016	Position input 10	Port Nos. 007 to 019 are used to specify a target position number. Numbers can be specified either as BCD or binary codes.		
2A		017	Position input 11			
2B		018	Position input 12			
3A		019	Position input 13			
3B		020	-			
4A		021	-			
4B		022	-			
5A		023	Error reset			This signal is used to reset minor errors. (The power must be reconnected to reset serious errors.)
5B		000	Start			This signal is used to cause the actuator to start moving to the selected position.
6A		001	Home return			This signal is used to perform home return.
6B		002	Servo ON	This signal is used to switch the servo on/off.		
7A		003	Push	This signal is used to perform push-motion operation.		
7B		004	Pause	When this signal is turned OFF while the actuator is moving, the actuator will pause. When the signal is turned ON, the actuator will resume and complete the remaining operation.		
8A		005	Cancellation	When this signal is turned OFF while the actuator is moving, the actuator will stop and the remaining operation will be cancelled.		
8B		006	Interpolation setting	With a 2-axis specification, turning ON this signal causes the actuator to move via linear interpolation.		
9A		007	Position input 1	Port Nos. 007 to 019 are used to specify a target position number. Numbers can be specified either as BCD or binary codes.		
9B		008	Position input 2			
10A		009	Position input 3			
10B		010	Position input 4			
11A		011	Position input 5			
11B		012	Position input 6			
12A		013	Position input 7			
12B		014	Position input 8			
13A		015	Position input 9			
13B		300	Alarm			This signal is output upon an alarm. (Contact B)
14A		301	Ready	This signal is output once the controller has started properly and entered a ready state.		
14B		302	Position complete	This signal is output upon completion of movement to the specified position.		
15A		303	Home return complete	This signal is output upon completion of home return.		
15B		304	Servo ON output	This signal is output while the servo is on.		
16A		305	Push motion complete	This signal is output upon completion of push-motion operation.		
16B		306	System-memory backup battery error	This signal is output when the system-memory backup battery voltage has dropped (to the warning level).		
17A		307	Absolute-data backup battery error	This signal is output when the absolute-data backup battery voltage has dropped (to the warning level).		
17B	N		0-V input	Connect 0V.		

Controller - Integrated type  
Slider Type  
Rod Type  
Arm / Flat Type  
Gripper / Rotary Type  
Cleanroom Type  
Splash Proof Type  
Controller  
Controller Models  
Gateway unit  
PS-24  
ERC2  
PCON  
ACON  
SCON  
PSEL  
ASEL  
SSEL  
XSEL

Explanation of I/O Functions

Positioner, Product-Type Switchover Mode

Pin number	Category	Port number	Positioner, product-type switchover mode	Function
1A	P24		24-V input	Connect 24V.
1B		016	Position/product type input 10	Port Nos. 007 to 022 are used to specify a target position number and a product type number. Position numbers and product type numbers are assigned by parameter settings. Numbers can be specified either as BCD or binary codes.
2A		017	Position/product type input 11	
2B		018	Position/product type input 12	
3A		019	Position/product type input 13	
3B		020	Position/product type input 14	
4A		021	Position/product type input 15	
4B		022	Position/product type input 16	
5A		023	Error reset	
5B		000	Start	
6A		001	Home return	
6B		002	Servo ON	This signal is used to switch the servo on/off.
7A		003	Push	This signal is used to perform push-motion operation.
7B		004	Pause	When this signal is turned OFF while the actuator is moving, the actuator will pause. When the signal is turned ON, the actuator will resume and complete the remaining operation.
8A		005	Cancellation	When this signal is turned OFF while the actuator is moving, the actuator will stop and the remaining operation will be cancelled.
8B		006	Interpolation setting	With a 2-axis specification, turning ON this signal causes the actuator to move via linear interpolation.
9A		007	Position/product type input 1	Port Nos. 007 to 022 are used to specify a target position number and a product type number. Position numbers and product type numbers are assigned by parameter settings. Numbers can be specified either as BCD or binary codes.
9B		008	Position/product type input 2	
10A		009	Position/product type input 3	
10B		010	Position/product type input 4	
11A		011	Position/product type input 5	
11B		012	Position/product type input 6	
12A		013	Position/product type input 7	
12B		014	Position/product type input 8	
13A		015	Position/product type input 9	
13B		300	Alarm	
14A		301	Ready	This signal is output once the controller has started properly and entered a ready state.
14B		302	Position complete	This signal is output upon completion of movement to the specified position.
15A		303	Home return complete	This signal is output upon completion of home return.
15B		304	Servo ON output	This signal is output while the servo is on.
16A		305	Push motion complete	This signal is output upon completion of push-motion operation.
16B		306	System-memory backup battery error	This signal is output when the system-memory backup battery voltage has dropped (to the warning level).
17A		307	Absolute-data backup battery error	This signal is output when the absolute-data backup battery voltage has dropped (to the warning level).
17B	N		0-V input	Connect 0V.

Wiring diagram

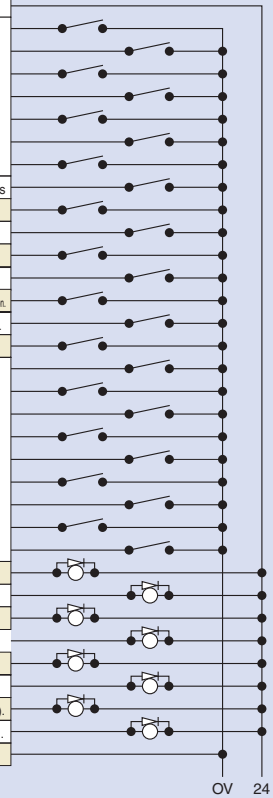

Positioner, 2-axis Independent Mode

Pin number	Category	Port number	Positioner	Function
1A	P24		24-V input	Connect 24V.
1B		016	Position input 10	Port Nos. 010 to 022 are used to specify a target position number. Position numbers for axis 1 and those for axis 2 are assigned by parameter settings. Numbers can be specified either as BCD or binary codes.
2A		017	Position input 11	
2B		018	Position input 12	
3A		019	Position input 13	
3B		020	Position input 14	
4A		021	Position input 15	
4B		022	Position input 16	
5A		023	Error reset	
5B		000	Start 1	
6A		001	Home return 1	
6B		002	Servo ON 1	This signal is used to switch on/off the servo for axis 1.
7A		003	Pause 1	When this signal is turned OFF while axis 1 is moving, the actuator will pause. When the signal is turned ON, the actuator will resume and complete the remaining operation.
7B		004	Cancellation 1	This signal is used to cancel the movement of axis 1.
8A		005	Start 2	
8B		006	Home return 2	
9A		007	Servo ON 2	This signal is used to switch on/off the servo for axis 2.
9B		008	Pause 2	When this signal is turned OFF while axis 2 is moving, the actuator will pause. When the signal is turned ON, the actuator will resume and complete the remaining operation.
10A		009	Cancellation 2	This signal is used to cancel the movement of axis 2.
10B		010	Position input 1	Port Nos. 010 to 022 are used to specify a target position number. Position numbers for axis 1 and those for axis 2 are assigned by parameter settings. Numbers can be specified either as BCD or binary codes.
11A		011	Position input 2	
11B		012	Position input 3	
12A		013	Position input 4	
12B		014	Position input 5	
13A		015	Position input 6	
13B		300	Alarm	This signal is output upon an alarm. (Contact B)
14A		301	Ready	This signal is output once the controller has started properly and entered a ready state.
14B		302	Position complete 1	This signal is output upon completion of movement of axis 1 to the specified position.
15A		303	Home return complete 1	This signal is output upon completion of home return of axis 1.
15B		304	Servo ON output 1	This signal is output while the servo for axis 1 is on.
16A		305	Position complete 2	This signal is output upon completion of movement of axis 2 to the specified position.
16B		306	Home return complete 2	This signal is output upon completion of home return of axis 2.
17A		307	Servo ON output 2	This signal is output while the servo for axis 2 is on.
17B	N		0-V input	Connect 0V.

Wiring diagram

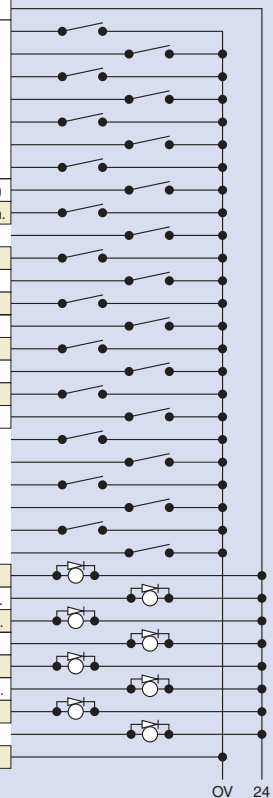

Explanation of I/O Functions

Positioner, Teaching Mode

Pin number	Category	Port number	Positioner	Function	
1A	Input	P24	24-V input	Connect 24V.	
1B			016	Axis 1 JOG-	While this signal is input, axis 1 moves in the negative direction.
2A			017	Axis 2 JOG+	While this signal is input, axis 2 moves in the positive direction.
2B			018	Axis 2 JOG-	While this signal is input, axis 2 moves in the negative direction.
3A			019	Inching specification (0.01mm)	These signals are used to specify an inching travel distance. (The travel distance is the sum of values specified by port Nos. 019 to 022.)
3B			020	Inching specification (0.1mm)	
4A			021	Inching specification (0.5mm)	
4B			022	Inching specification (1mm)	
5A			023	Error reset	
5B			000	Start	This signal is used to cause the actuator to start moving to the selected position.
6A			001	Servo ON	This signal is used to switch the servo on/off.
6B			002	Pause	When this signal is turned OFF while the actuator is moving, the actuator will pause. When the signal is turned ON, the actuator will resume and complete the remaining operation.
7A			003	Position input 1	Port Nos. 003 to 013 are used to specify a target position number and a position number under which to input the current position.
7B			004	Position input 2	
8A			005	Position input 3	
8B			006	Position input 4	
9A			007	Position input 5	
9B	008	Position input 6			
10A	009	Position input 7			
10B	010	Position input 8			
11A	011	Position input 9			
11B	012	Position input 10			
12A	013	Position input 11			
12B	014	Teaching mode specification	When the teaching mode specification signal at port No. 014 is ON, the current value will be written under the specified position number upon turning ON of the start signal at port No. 000.		
13A	015	Axis 1 JOG+	While this signal is input, axis 1 moves in the positive direction.		
13B	Output	300	Alarm	This signal is output upon an alarm. (Contact B)	
14A		301	Ready	This signal is output once the controller has started properly and entered a ready state.	
14B		302	Position complete	This signal is output upon completion of movement to the specified position.	
15A		303	Home return complete	This signal is output upon completion of home return.	
15B		304	Servo ON output	This signal is output while the servo is on.	
16A		305	-	-	
16B		306	System-memory backup battery error	This signal is output when the system-memory backup battery voltage has dropped (to the warning level).	
17A		307	Absolute-data backup battery error	This signal is output when the absolute-data backup battery voltage has dropped (to the warning level).	
17B	N	-	0-V input	Connect 0V.	

Wiring diagram

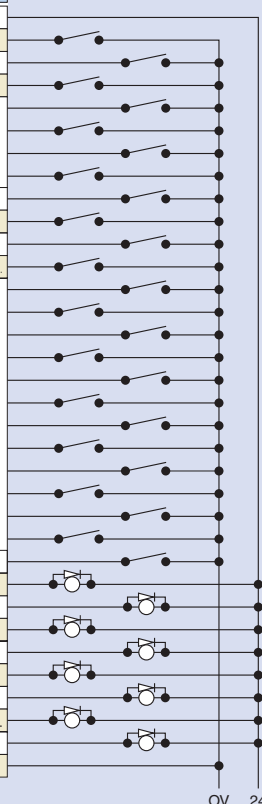

Positioner, DS-S-C1 Compatible Mode

Pin number	Category	Port number	Positioner	Function	
1A	Input	P24	24-V input	Connect 24V.	
1B			016	Position No.1000	(Same as port Nos. 004 to 015)
2A			017	-	-
2B			018	-	-
3A			019	-	-
3B			020	-	-
4A			021	-	-
4B			022	-	-
5A			023	CPU reset	This signal is used to reset the system to create the same condition after power reconnection.
5B			000	Start	This signal is used to cause the actuator to start moving to the selected position.
6A			001	Hold (pause)	When this signal is turned OFF while the actuator is moving, the actuator will pause. When the signal is turned ON, the actuator will resume and complete the remaining operation.
6B			002	Cancellation	When this signal is turned OFF while the actuator is moving, the actuator will stop and the remaining operation will be cancelled.
7A			003	Interpolation setting	With a 2-axis specification, turning ON this signal causes the actuator to move via linear interpolation.
7B			004	Position No.1	Port Nos. 004 to 016 are used to specify a target position number. Numbers can be specified either as BCD or binary codes.
8A			005	Position No.2	
8B			006	Position No.4	
9A			007	Position No.8	
9B	008	Position No.10			
10A	009	Position No.20			
10B	010	Position No.40			
11A	011	Position No.80			
11B	012	Position No.100			
12A	013	Position No.200			
12B	014	Position No.400			
13A	015	Position No.800			
13B	Output	300	Alarm	This signal is output upon an alarm. (Contact A)	
14A		301	Ready	This signal is output once the controller has started properly and entered a ready state.	
14B		302	Position complete	This signal is output upon completion of movement to the specified position.	
15A		303	-	-	
15B		304	-	-	
16A		305	-	-	
16B		306	System-memory backup battery error	This signal is output when the system-memory backup battery voltage has dropped (to the warning level).	
17A		307	Absolute-data backup battery error	This signal is output when the absolute-data backup battery voltage has dropped (to the warning level).	
17B	N	-	0-V input	Connect 0V.	

Wiring diagram

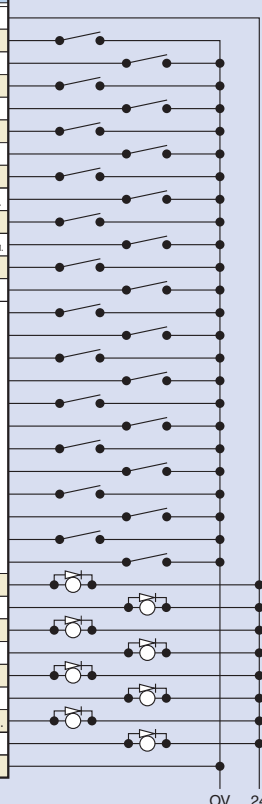

- Controller - Integrated type
- Slider Type
- Rod Type
- Arm / Flat Type
- Gripper / Rotary Type
- Cleanroom Type
- Splash Proof Type
- Controller
- Controller Models
- Gateway unit
- PS-24
- ERC2
- PCON
- ACON
- SCON
- PSEL
- ASEL
- SSEL
- XSEL

**Specification Table**

	Item	Specification	
Basic specifications	Connectable actuators	RCA series actuator	
	Input power supply	DC24V ±10%	
	Power-supply capacity	Control power: 1.2A max. Motor power: Rating 1.7A / Peak 5A (per axis)	
	Dielectric strength voltage	500VDC, 10MΩ or above	
	Breakdown resistance	500VAC, 1 minute	
	Rush current	30A max.	
	Vibration resistance	XYZ directions One-side amplitude 0.035 mm (continuous), 0.075 g 4.9m/s <sup>2</sup> (continuous), 0.8m/s <sup>2</sup> (continuous)	
Control specifications	Number of controlled axes	1 axis/2 axes	
	Maximum total output of connected axes	60W (30W+30W)	
	Position detection method	Incremental encoder / Absolute encoder	
	Speed setting	From 1mm/s. The maximum limit varies depending on the actuator.	
	Acceleration setting	From 0.01G. The maximum limit varies depending on the actuator.	
Program	Operation method	Program operation / Positioner operation (switchable)	
	Programming language	Super SEL language	
	Number of programs	64 programs	
	Number of program steps	2,000 steps	
	Number of multi-tasking programs	8 programs	
	Number of positioning points	1,500 points	
	Data storage device	Flash ROM (A system-memory backup battery can be added as an option)	
	Data input method	Teaching pendant or PC software	
	Communication	Number of I/O points	24 input points / 8 output points (NPN or PNP selectable)
		I/O power supply	Externally supplied 24VDC ± 10%
PIO cable		CB-DS-PIO□□□(supplied with the controller)	
Serial communication function		RS232C (D-sub, half-pitch connector) / USB connector	
Field network		(To be supported in the future)	
Motor cable		CB-ACS-MA□□□(20m max.)	
Encoder cable		CB-ACS-PA□□□(20m max.)	
General specifications	Protective functions	Motor overcurrent, motor driver temperature check, overload check, encoder open-circuit check, soft limit over, system error, battery error, etc.	
	Ambient operating temperature, humidity	0~40°C 10~95% (non-condensing)	
	Operating ambience	Free from corrosive gases. In particular, there shall be no significant powder dust.	
	Protection class	IP20	
	Weight	Approx. 450g	
	External dimensions	43mm (W) ×159mm (H) ×110mm (D)	

**External Dimensions**

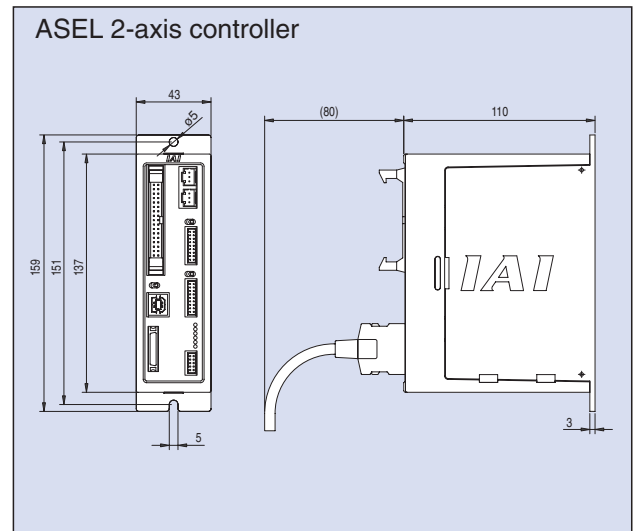
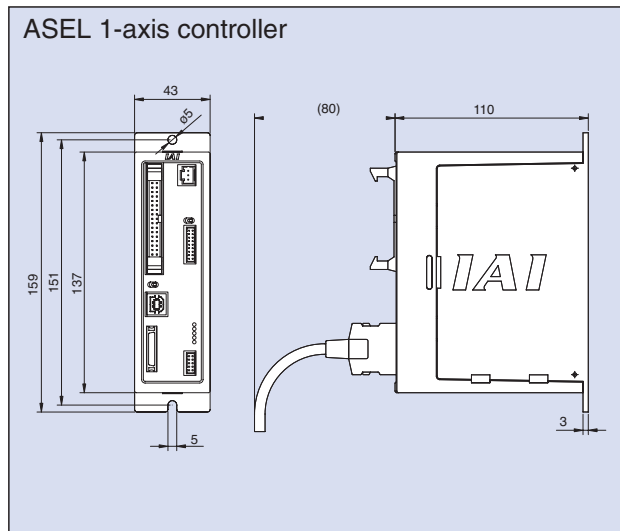

Name of Each Part

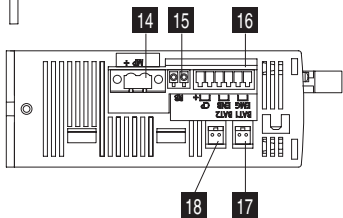
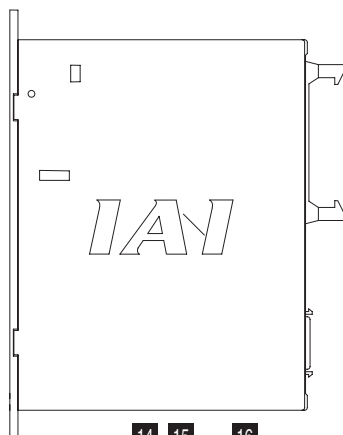
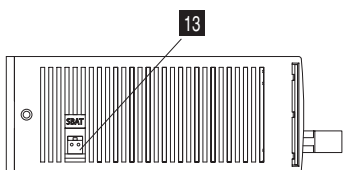
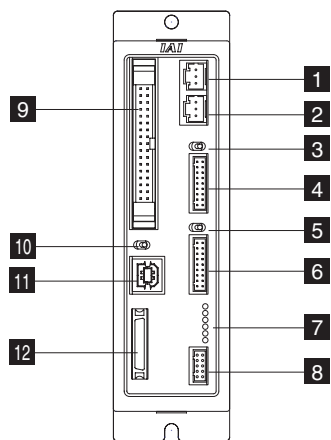

**1** Motor connector for axis 1

Connect the motor cable of the axis 1 actuator.

**2** Motor connector for axis 2

Connect the motor cable of the axis 2 actuator.

**3** Brake switch for axis 1

This switch is used to release the axis brake. Setting it to the left position (RLS side) forcibly releases the brake, while setting it to the right position (NOM side) causes the controller to automatically control the brake.

**4** Encoder connector for axis 1

Connect the encoder cable of the axis 1 actuator.

**5** Brake switch for axis 2

This switch is used to release the axis brake. Setting it to the left position (RLS side) forcibly releases the brake, while setting it to the right position (NOM side) causes the controller to automatically control the brake.

**6** Encoder connector for axis 2

Connect the encoder cable of the axis 2 actuator.

**7** Status indicator LEDs

These LEDs are used to indicate the operating condition of the controller.

Indication details are as follows:

PWR: This LED indicates that the controller is receiving power.

RDY: This LED indicates that the controller is ready to perform program operation.

ALM: This LED indicates that the controller is abnormal.

EMG: This LED indicates that an emergency stop is actuated and the drive source is cut off.

SV1: This LED indicates that the axis 1 actuator servo is on.

SV2: This LED indicates that the axis 2 actuator servo is on.

**8** Panel unit connector

A connector for the panel unit (optional) that displays the controller status and error numbers.

**9** I/O connector

A connector for interface I/Os.

A 34-pin flat connector is used for the DIO (24 IN/8 OUT) interface.

The I/O power is also supplied to the controller through this connector (pins 1 and 34).

**10** Mode switch

This switch is used to specify the running mode of the controller. The left position indicates the MANU (manual operation) mode, while the right position indicates the AUTO (automatic operation) mode. Teaching can only be performed as manual operation, and automatic operation using external I/Os is not possible in the MANU mode.

**11** USB connector

A connector for PC connection via USB. If the USB connector is connected, the TP connector is disabled and all communication inputs to the TP connector are cut off.

**12** Teaching pendant (TP) connector

A half-pitch I/O 26-pin connector that connects a teaching pendant when the running mode is MANU. A special conversion cable is needed to connect a conventional D-sub, 25-pin connector.

**13** System-memory backup battery connector

If you wish to retain the various data recorded in the SRAM of the controller even after the power is cut off, connect the necessary battery to this connector.

This battery is installed externally to the unit. The controller does not come standard with the battery (it must be specified as an option).

**14** Motor power input connector

This connector is used to input the motor power. It consists of a 2-pin, 2-piece connector by Phoenix Contact.

**15** External regenerative resistor connector

A connector for the regenerative resistor that must be connected when the built-in regenerative resistor alone does not offer sufficient capacity in high-acceleration/high-load operation, etc.

Whether or not an external regenerative resistor is necessary depends on the conditions of your specific application such as the axis configuration.

**16** Control power/system input connector

This connector is used to connect the control power input, emergency stop switch, and enable switch.

It consists of a 6-pin, 2-piece connector by Phoenix Contact.

**17** Absolute-data backup battery connector for axis 1

A connector for the battery that backs up absolute data when the actuator uses an absolute encoder. Secure installation of the battery is the customer's responsibility.

**18** Absolute-data backup battery connector for axis 2

A connector for the battery that backs up absolute data when the actuator uses an absolute encoder. Secure installation of the battery is the customer's responsibility.

- Controller - Integrated type
- Slider Type
- Rod Type
- Arm / Flat Type
- Gripper / Rotary Type
- Cleanroom Type
- Splash Proof Type
- Controller
- Controller Models
- Gateway unit
- PS-24
- ERC2
- PCON
- ACON
- SCON
- PSEL
- ASEL
- SSEL
- XSEL

## Teaching pendant

**Features** A teaching device providing program/position input function, test operation function, monitoring function, and more.

**Model**

Model	Description
IA-T-X-J	Standard type with connector conversion cable
IA-T-X	Standard type
IA-T-XD-J	Deadman switch type with connector conversion cable
IA-T-XD	Deadman switch type
IA-T-XA-J	ANSI type with connector conversion cable
IA-T-XA	ANSI type

IA-T-X/XD

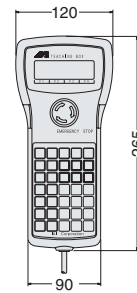

IA-T-XA

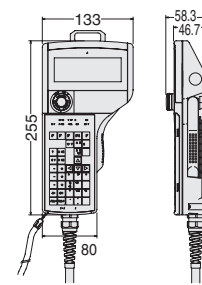

**Configuration**

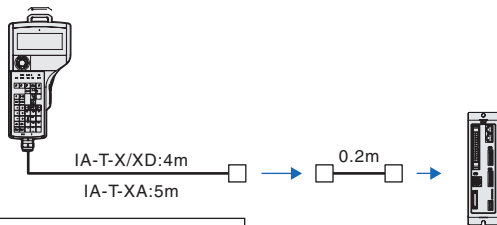

**NOTE**  
The PSEL controller is supported by version 1.40 or later (or 1.30 or later with the ANSI type).

Conversion cable:CB-SEL-SJ002

**Specifications**

Item	IA-T-X/XD	IA-T-XA
Ambient operating temperature, humidity	Temperature 0~40°C, Humidity 85% RH or below	
Operating ambience	Free from corrosive gases. In particular, there shall be no significant powder dust.	Protective structure conforming to IP54
Weight	Approx. 650g	Approx. 600g (excluding cable)
Cable length	4m	5m
Display	LCD with 20 characters x 4 lines	LCD with 32 characters x 8 lines

## PC Software (Windows Only)

**Features** A startup support software program offering program/position input function, test operation function, monitoring function, and more. The functions needed for debugging have been enhanced to help reduce the startup time.

**Model** IA-101-X-MW-J (with RS232C Cable + Connector Conversion Cable)

**Configuration**

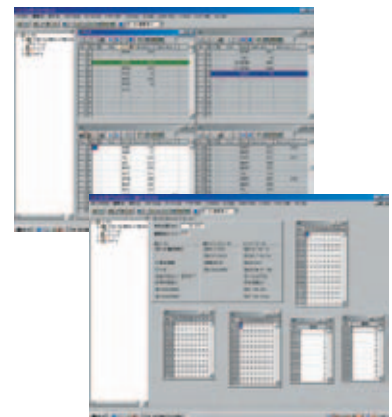
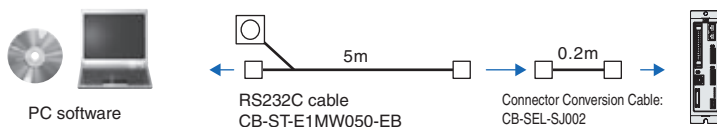

**NOTE**  
The PSEL controller is supported by version 7.0.0.0 or later.

**Model** IA-101-X-USB (with USB Cable)

**Configuration**

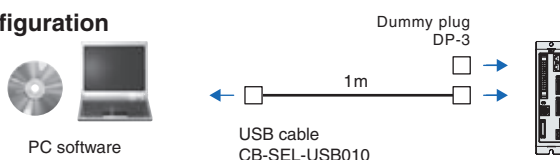

Options

Panel Unit

**Features** A display for checking controller error codes and active program numbers.

**Model** PU-1 (Cable Length 3m)

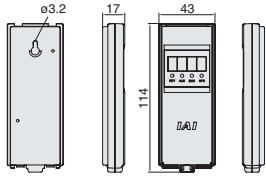

Absolute-Data Backup Battery

**Features** This battery backs up absolute data when an absolute-type actuator is operated. Same as the system-memory backup battery.

**Model** AB-5



System-Memory Backup Battery

**Features** If your programs use global flags, etc., you need this battery to retain data even after the power is turned off.

**Model** AB-5-CS (with Case)  
AB-5 (Battery Only)



Dummy plug

**Features** When connecting your SSEL controller to a PC using a USB cable, install this plug on the teaching port to cut off the enable circuit. (This plug comes with the PC software IA-101-X-USB.)

**Model** DP-3



USB cable

**Features** Use this cable to connect your controller with USB port to a PC. If your controller has no USB port (XSEL), connect a RS232C cable to a USB cable via a USB conversion adapter and connect the USB cable to the USB port on the PC.

**Model** CB-SEL-USB010 (Cable Length 1m)



Connector conversion cable

**Features** This conversion cable is used to connect a D-sub, 25-pin connector for teaching pendant or PC software to the teaching connector (half-pitch) on the ASEL controller.

**Model** CB-SEL-SJ002 (Cable Length 0.2m)



Spare Parts

Should you require spare parts after the purchase of your product for replacing the original cables, etc., refer to the model names specified below.

Motor Cable

Model **CB-ACS-MA** □ □ □

\* The standard motor cable is a robot cable. \* □ □ □ indicates the cable length (L). Lengths up to 20 m can be specified. Example) 080 = 8 m

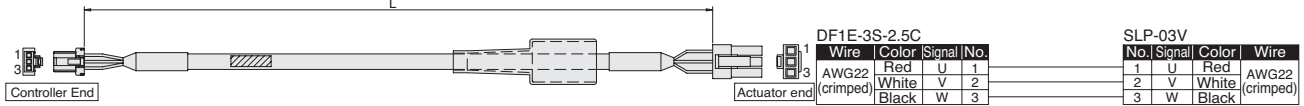

Encoder Cable/ Encoder Robot Cable

Model **CB-ACS-PA** □ □ □ / **CB-ACS-PA** □ □ □ -RB

\* The standard encoder cable is a normal cable. A robot cable can be specified as an option. \* □ □ □ indicates the cable length (L). Lengths up to 20 m can be specified. Example) 080 = 8 m

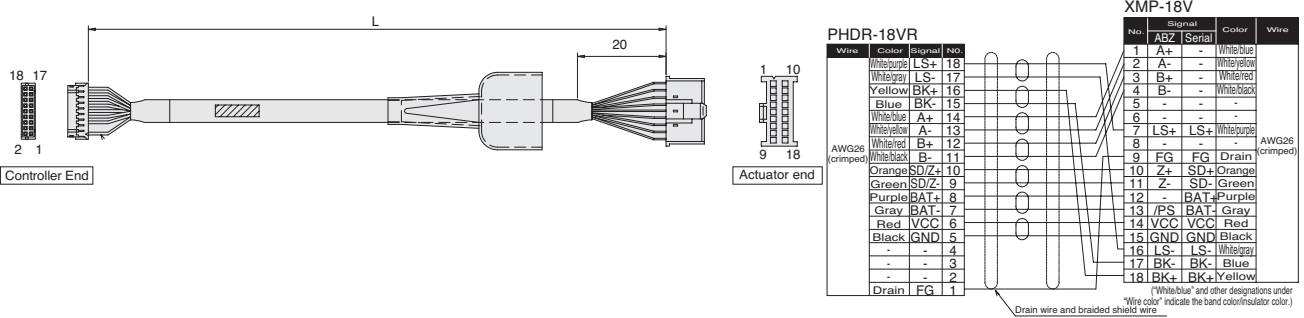

I/O Flat Cable

Model **CB-DS-PIO** □ □ □

\* □ □ □ indicates the cable length (L). Lengths up to 20 m can be specified. Example) 080 = 8 m

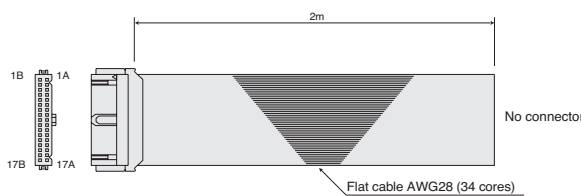

No.	Color	Wire	No.	Color	Wire
1A	Brown1		9B	Gray2	
1B	Red1		10A	White2	
2A	Orange1		10B	Black2	
2B	Yellow1		11A	Brown-3	
3A	Green1		11B	Red3	
3B	Blue1		12A	Orange3	
4A	Purple1		12B	Yellow3	
4B	Gray1	Flat cable	13A	Green3	Flat cable
5A	White1	pressure	13B	Blue3	pressure
5B	Black1	-welded	14A	Purple3	-welded
6A	Brown-2		14B	Gray3	
6B	Red2		15A	White3	
7A	Orange2		15B	Black3	
7B	Yellow2		16A	Brown-4	
8A	Green2		16B	Red4	
8B	Blue2		17A	Orange4	
9A	Purple2		17B	Yellow4	