

PROFIBUS-Gateway

*Interface for
Controlling of
RoboCylinders in a
PROFIBUS network*



Features

- Connection of decentralized RoboCylinder field bus equipment to upper level, existing Profibus installations
- On both sides transparent transition for input and output data between PROFIBUS and MODBUS
- Confirmation assurance by IAI as member of PROFIBUS user association



Application Diagram

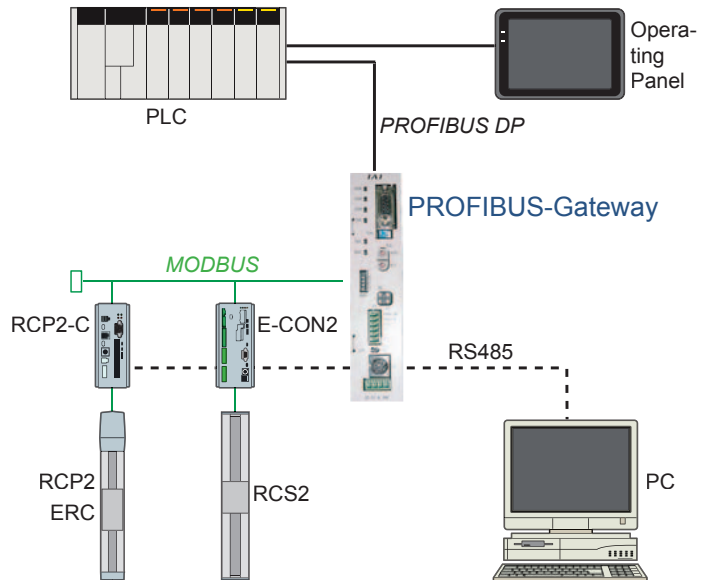

Single Axis Control

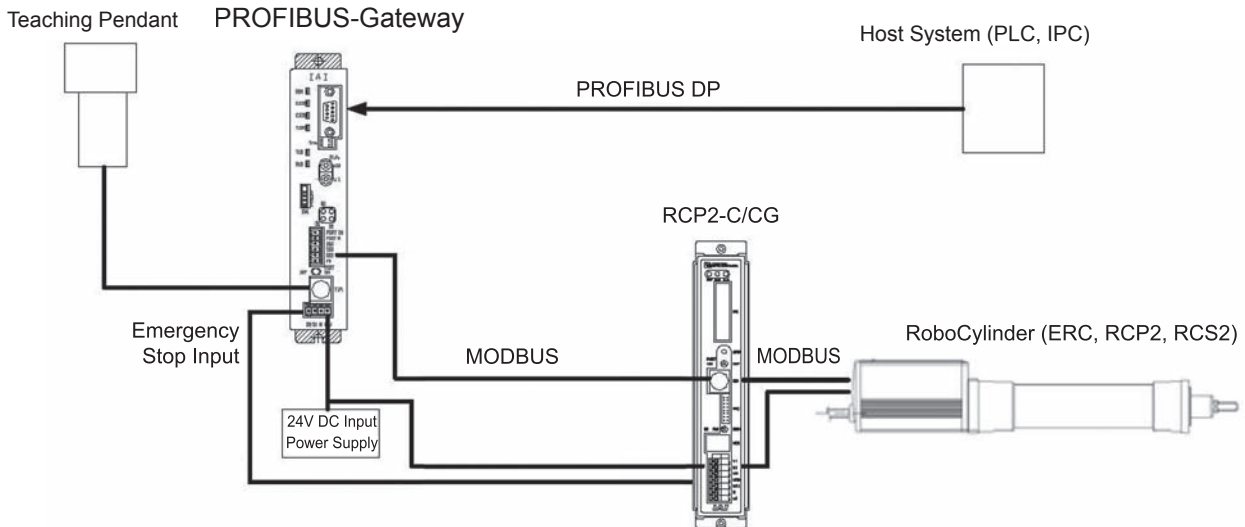

Multi Axes Control

The following explains how to connect multiple controllers using a PC or PLC with Profibus module as the host

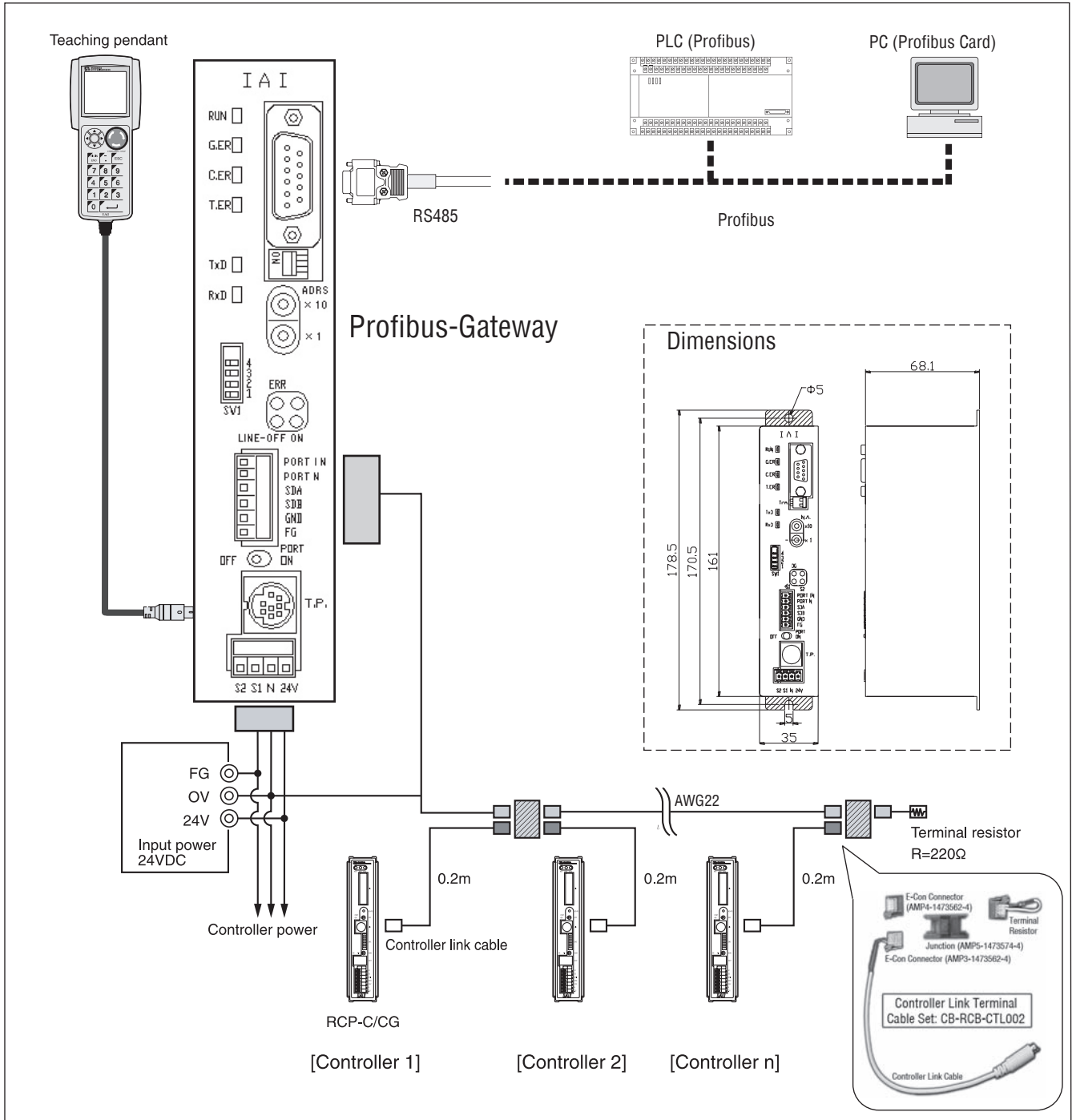

Basic Specifications

Specification Item	Description
Max. number of axes that can be connected	16 Axes
Max. cable length	100 m
Terminal resistor	220 Ω (provide a communication path via profibus connection and a terminal resistor at the end)
Power supply	24 V DC ±10 % (max. 0,3 A)
Operating temperature and humidity	0 ~ 40 °C, 85 % RH or less (non-condensing)
Protection degree	IP 20
Weight	480 g
External dimensions	35 mm (W) x 178.5 mm (H) x 68.1 mm (D)