

Clean Room Type ROBO Cylinder **RCP2CR**



A New, Clean Room Type ROBO Cylinder Conforming to Cleanliness Class 10

The RCP2CR is a clean room type motorized slider that achieves a cleanliness level of class 10 by incorporating an air-suction mechanism as well as a stainless steel enclosure that prevents internal dust generation.



Features

- Maximum 64 positioning points**
A maximum of 64 positioning points can be registered to support various types of loads.
- Positioning repeatability of ± 0.02 mm**
The built-in linear guide and ball screw will maintain accurate positioning performance for an extended period.
- Same control action as an air cylinder (air cylinder mode)**
By changing the controller setting, the RCP2CR can be operated in the same manner as turning on/off of the electromagnetic valve of an air cylinder.
- AQ seal (resin-solidified lubricating oil) for long maintenance-free period**
AQ seal reduces the greasing frequency and thus significantly improves maintainability.
- Conformance to cleanliness class 10, achieved by internal air suction and a modified slider structure**
Compared with the standard specification, the RCP2CR adopts clean room grease, a modified slider roller structure and an internal air-suction port to meet the requirements of a cleanliness class 10 equipment (*1).

*1 Cleanliness class 10 is guaranteed only in a horizontal application. Cleanliness level of class 10 may not be achieved if the actuator is positioned sideways in a horizontal application, or used in a vertical application.

Models

Actuator model

RCP2CR — SA5 — A — PM — 12 — 500 — P1 — M — NM

Series
RCP2CR

Encoder type
A: Absolute
I: Incremental

Lead
3: 3mm
4: 4mm
5: 5mm
6: 6mm
8: 8mm
10: 10mm
12: 12mm
16: 16mm
20: 20mm

Applicable controller
P1: RCP2-C□
RCP2-CG

Options
B: Brake
BE: Brake (Cable outlet direction: End) (*)
BL: Brake (Cable outlet direction: Left) (*)
BR: Brake (Cable outlet direction: Right) (*)

Type

SA5: Slider width 52mm
SA6: Slider width 58mm
SA7: Slider width 73mm
SS: Slider width 60mm
SM: Slider width 80mm

Motor

PM: Pulse motor

Stroke (mm)

50 ~ 1000 (*)
*Range varies depending on the model

Cable length

N: No cable
P: 1m
S: 3m
M: 5m
X□□: Specify the desired length
R□□: Robot cable

NM: Reversed-home specification
VR: Suction-pipe joint R/L-reversed
*BE, BL and BR are exclusively for SA5, SA6 and SA7

Controller model

Refer to the back cover.

* Selectable leads vary depending on the model

Specification Table

	Slider type	Stroke (mm), maximum speed (mm/s)													Load capacity		Lead (mm)	Suction rate (N/l/min)	Model	
		50	100	150	200	250	300	350	400	450	500	550	600	700	800	900				1000
															(kg)	(kg)				
	Motor straight type	600													4	1□	12□	50□	RCP2CR-SA5-I-PM-12-***	
		300													8	2.5□	6□	30□	RCP2CR-SA5-I-PM-6-***	
		150													8	4.5□	3□	15□	RCP2CR-SA5-I-PM-3-***	
	Slider type	600													6	1.5 ~ 0.5□	12□	50□	RCP2CR-SA6-I-PM-12-***	
		300													12□	3 ~ 1.5□	6□	30□	RCP2CR-SA6-I-PM-6-***	
		150													12□	6 ~ 3□	3	15□	RCP2CR-SA6-I-PM-3-***	
		533(400)													25 ~ 5□	5 ~ 1□	16□	70□	RCP2CR-SA7-I-PM-16-***	
		266													30 ~ 5□	10 ~ 1□	8□	40□	RCP2CR-SA7-I-PM-8-***	
		133													30□	15 ~ 3□	4□	30□	RCP2CR-SA7-I-PM-4-***	
		600													30 ~ 3□	4 ~ 0.5□	12□	50□	RCP2CR-SS-I-PM-12-***	
		300													30 ~ 20	8 ~ 2□	6□	30□	RCP2CR-SS-I-PM-6-***	
		150													30 ~ 20□	12 ~ 1□	3□	15□	RCP2CR-SS-I-PM-3-***	
		666(500)													40 ~ 5□	5 ~ 0.5□	20□	80□	RCP2CR-SM-I-PM-20-***	
		333(300)													50 ~ 4□	12 ~ 0.5□	10□	40□	RCP2CR-SM-I-PM-10-***	
		165(150)													55 ~ 8	20 ~ 0.5	5□	20	RCP2CR-SM-I-PM-5-***	

RCP2CR-SA6

Clean Room Type ROBO Cylinder, Slider Type,
Slider Width 58mm, Pulse Motor, Straight Shape

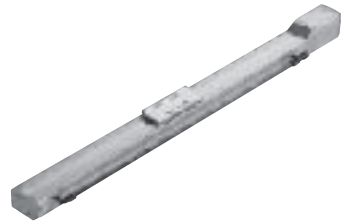

Type / Slider (58mm wide) Stroke / 50 ~600mm Load capacity / 12kg (horizontal)/6kg (vertical)

Model Specification Items Series — Type — Encoder type — Motor output — Lead — Stroke — Applicable controller — Cable length — Option
(Example) : RCP2CR — SA6□ □ □ □ — □ PM□ — □□ — □□□□ — □ □ P□ — □ □ S□ — □ BE

Models/Specifications

* The maximum speed of the RCP2 series will vary according to the weight of the load installed on the slider (or rod). Refer to the diagram on the back cover for the relationship of speed and load capacity.

Model	Encoder type	Motor type	Lead (mm)	Stroke 50mm increments (mm)	Speed (Note 1) (mm/s)	Load capacity (Note 2)		Suction rate (Nℓ / min)
						Horizontal (kg)	Vertical (kg)	
RCP2CR-SA6- 1 -PM-12- 2 -P1- 3 - 4	Absolute Incremental	Pulse motor	12	50 ~ 600	10 ~ 600	6	1.5 ~ 0.5	50
RCP2CR-SA6- 1 -PM-6- 2 -P1- 3 - 4			5 ~ 300		12	3 ~ 1.5	30	
RCP2CR-SA6- 1 -PM-3- 2 -P1- 3 - 4			1 ~ 150		12	6 ~ 3	15	

* In the above model names, **1** indicates the encoder type, **2** the stroke, **3** the cable length, and **4** the applicable options.

Options

Name	Type	Reference Page
Brake (Cable outlet direction: End)	BE	—
Brake (Cable outlet direction: Left)	BL	—
Brake (Cable outlet direction: Right)	BR	—
Reversed-home specification	NM	—
Suction-pipe joint R/L-reversed	VR	—

Common Specifications

Drive system	Ball screw ϕ 10mm, rolled C10
Positioning repeatability	\pm 0.02mm
Backlash	0.1mm or less
Guide	Integrated with base
Allowable load moment (Note 3)	Ma: 8.9N · m Mb: 12.7N · m Mc: 18.6N · m
Overhung load length	Ma/Mb/Mc directions: 220mm or less
Base	Material: Aluminum with white alumite treatment
Cable length (Note 4)	N: No cable, P: 1m, S: 3m, M: 5m, X□□: Length Specification, R□□: Robot cable

Dimensions

* With the reversed-home specification, the specification on the motor side (distance to the home) and that on the counter-motor side are reversed.

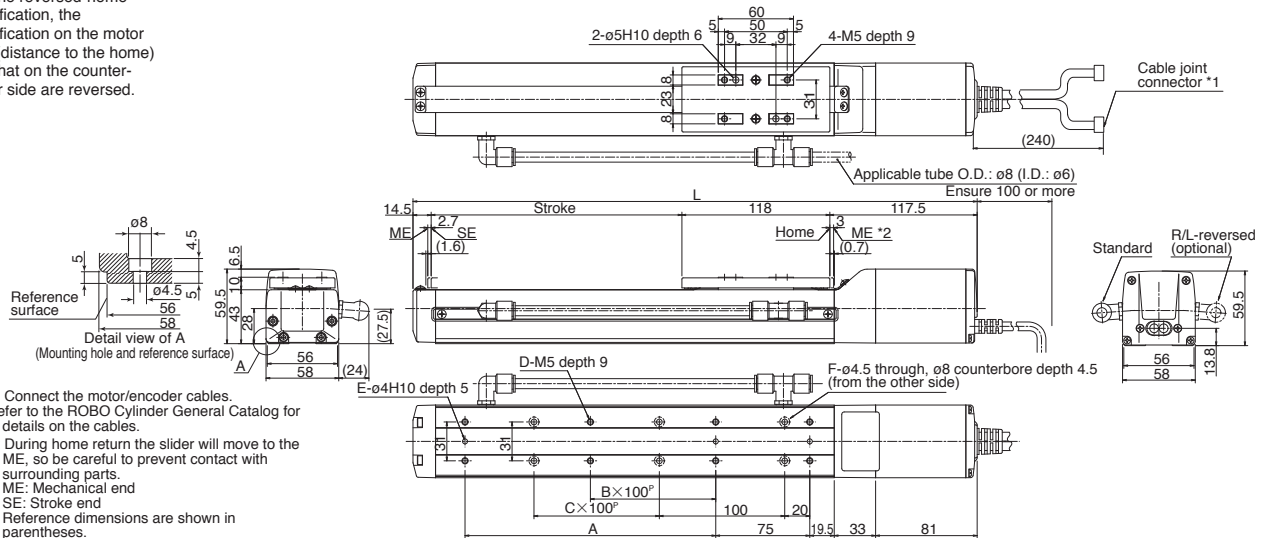

*1 Connect the motor/encoder cables. Refer to the ROBO Cylinder General Catalog for details on the cables.

*2 During home return the slider will move to the ME, so be careful to prevent contact with surrounding parts.
ME: Mechanical end
SE: Stroke end
Reference dimensions are shown in parentheses.

Brake Dimensions

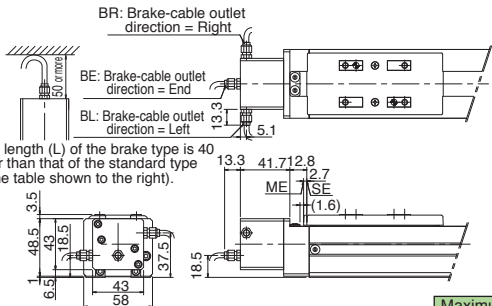

* The overall length (L) of the brake type is 40 mm longer than that of the standard type (refer to the table shown to the right).

Dimensions, Weight and Maximum Speed by Stroke (Note 1)

Stroke	50	100	150	200	250	300	350	400	450	500	550	600
L	300	350	400	450	500	550	600	650	700	750	800	850
A	0	100	100	200	200	300	300	400	400	500	500	600
B	0	0	0	1	1	2	2	3	3	4	4	5
C	0	0	1	1	2	2	3	3	4	4	5	5
D	4	6	6	8	8	10	10	12	12	14	14	16
E	2	3	3	3	3	3	3	3	3	3	3	3
F	4	4	6	6	8	8	10	10	12	12	14	14
Weight (kg)	2.0	2.2	2.3	2.4	2.6	2.7	2.9	3.0	3.1	3.3	3.4	3.6
Maximum speed (mm/s)	Lead: 12 600											
	Lead: 6 300											
	Lead: 3 150											

* Varies depending on the stroke.

Applicable Controller Specifications

Applicable controller	Maximum number of controlled axes	Compatible encoder type	Program Operation	Power supply voltage
RCP2-C	1 axis	Absolute	Positioner	DC24V
RCP2-CG	1 axis	Incremental		



Caution

(Note 1) A longer stroke will result in a lower maximum speed to prevent the ball screw from reaching a dangerous speed. (Refer to the above table for the maximum speed at a given stroke.)
(Note 2) Load capacity based on an acceleration of 0.3 G (or 0.2 G if the lead is 3 or in the case of a vertical application).
(Note 3) Based on a traveling life of 5,000 km.
(Note 4) The maximum cable length is 15 m for the absolute type and 20 m for the incremental type. Specify the desired length in meters (ex. X08 = 8 m).

RCP2CR-SS

Clean Room Type ROBO Cylinder, Slider Type with Iron Base, Slider Width 60mm, Pulse Motor, Straight Shape



Type / Slider (60mm wide) Stroke / 100 ~600mm Load capacity / 30kg (horizontal)/12kg (vertical)

Model Specification Items Series Type Encoder type Motor output Lead Stroke Applicable controller Cable length Option
 (Example) : RCP2CR - SS□ - □ □ □ - □ PM□ - □6□ - B□0□ - □ □ P□ - □ □ S□ - □B

Models/Specifications

* The maximum speed of the RCP2 series will vary according to the weight of the load installed on the slider (or rod). Refer to the diagram on the back cover for the relationship of speed and load capacity.

Model	Encoder type	Motor type	Lead (mm)	Stroke 50mm increments (mm)	Speed (Note 1) (mm/s)	Load capacity (Note 2)		Suction rate (N / min)
						Horizontal (kg)	Vertical (kg)	
RCP2CR-SS- 1 -PM-12- 2 -P1- 3 - 4	Absolute Incremental	Pulse motor	12	100 ~ 600	10 ~ 600	30 ~ 3	4 ~ 0.5	50
RCP2CR-SS- 1 -PM-6- 2 -P1- 3 - 4			6		5 ~ 300	30 ~ 20	8 ~ 2	30
RCP2CR-SS- 1 -PM-3- 2 -P1- 3 - 4			3		1 ~ 150	30 ~ 20	12 ~ 1	15

* In the above model names, **1** indicates the encoder type, **2** the stroke, **3** the cable length, and **4** the applicable options.

Options

Name	Type	Reference Page
Brake	B	—
Reversed-home specification	NM	—
Suction-pipe joint R/L-reversed	VR	—

Common Specifications

Drive system	Ball screw ϕ 12mm, rolled C10
Positioning repeatability	\pm 0.02mm
Backlash	0.05mm or less
Guide	Integrated with base
Allowable load moment (Note 3)	Ma: 14.7N · m Mb: 14.7N · m Mc: 33.3N · m
Overhung load length	Ma/Mb/Mc directions: 300mm or less
Base	Material: Special alloy steel
Cable length (Note 4)	N: No cable, P: 1m, S: 3m, M: 5m, X□□: Length Specification, R□□: Robot cable

Dimensions

* With the reversed-home specification, the specification on the motor side (distance to the home) and that on the counter-motor side are reversed.

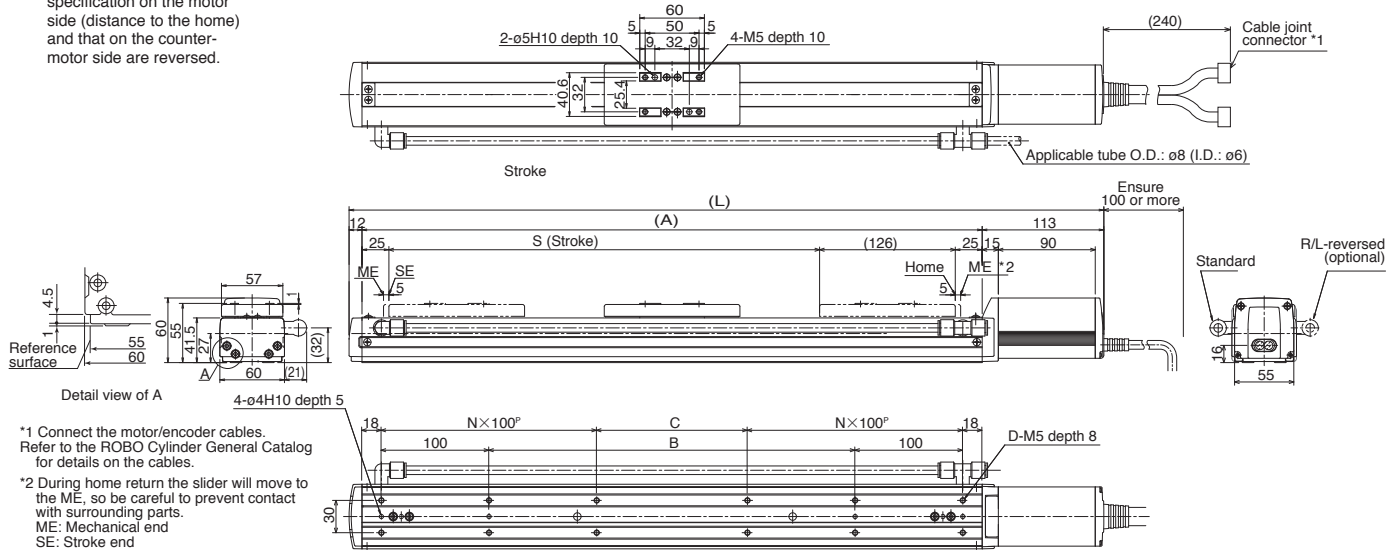

*1 Connect the motor/encoder cables. Refer to the ROBO Cylinder General Catalog for details on the cables.

*2 During home return the slider will move to the ME, so be careful to prevent contact with surrounding parts.
 ME: Mechanical end
 SE: Stroke end
 Reference dimensions are shown in parentheses.

Brake Dimensions

* The overall length (L) of the brake type is 24.5 mm longer than that of the standard type (refer to the table shown to the right).

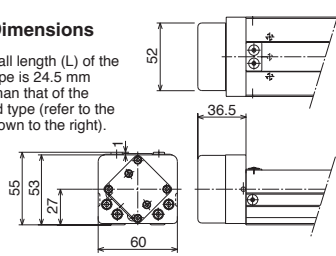

* The brake cable is routed inside the slider and is connected to the motor cable.

Dimensions, Weight and Maximum Speed by Stroke (Note 1)

Stroke	100	200	300	400	500	600
L	401	501	601	701	801	901
A	276	376	476	576	676	776
B	40	140	240	340	440	540
C	40	140	40	140	40	140
D	8	8	12	12	16	16
N	1	1	2	2	3	3
Weight (kg)	3.6	4.2	4.9	5.6	6.3	6.9
Maximum speed (mm/s)	Lead: 12 600 470 Lead: 6 300 230 Lead: 3 150 115					



Caution

(Note 1) A longer stroke will result in a lower maximum speed to prevent the ball screw from reaching a dangerous speed. (Refer to the above table for the maximum speed at a given stroke.)
 (Note 2) Load capacity based on an acceleration of 0.3 G (or 0.2 G if the lead is 3 or in the case of a vertical application).
 (Note 3) Based on a travel life of 10,000 km.
 (Note 4) The maximum cable length is 15 m for the absolute type and 20 m for the incremental type. Specify the desired length in meters (ex. X08 = 8 m).

Applicable Controller Specifications

Applicable controller	Maximum number of controlled axes	Compatible encoder type	Program Operation	Power supply voltage
RCP2-C	1 axis	Absolute	Positioner	DC24V
RCP2-CG	1 axis	Incremental		

Correlation Diagram of Speed and Load Capacity

Maximum speed
600mm/sec



High-Speed Type

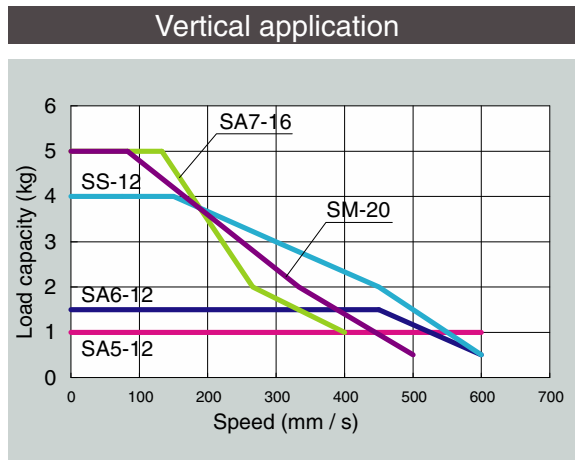
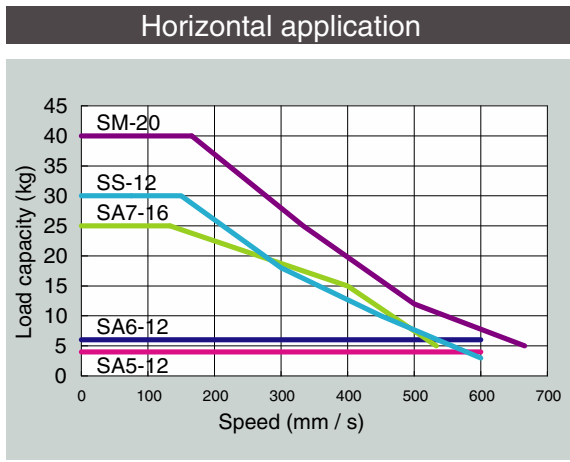

300mm/sec

Medium-Speed Type

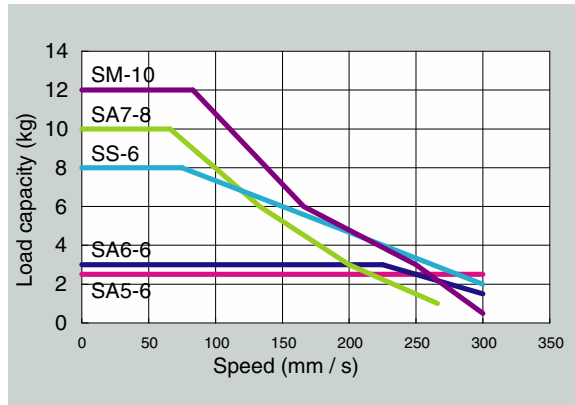
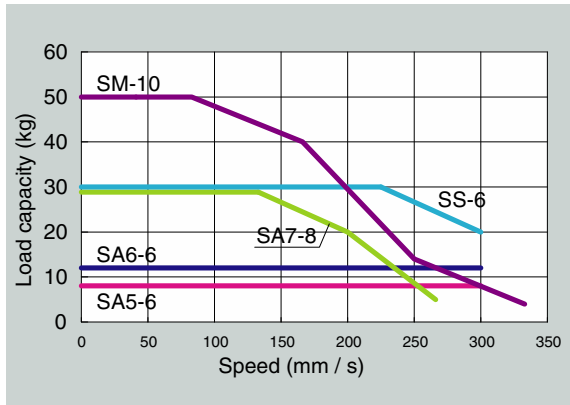

150mm/sec

Low-Speed Type

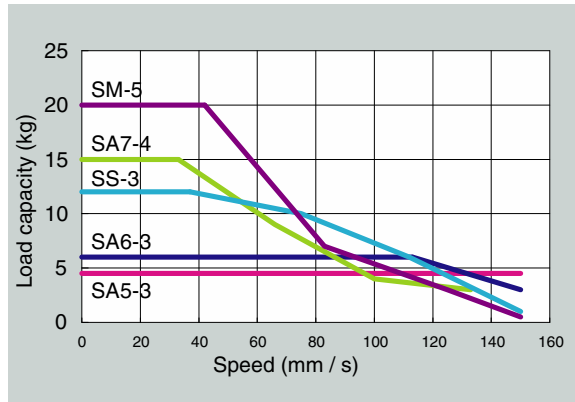
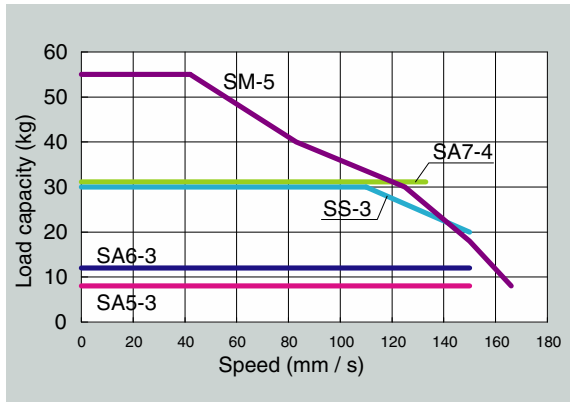

(Note) The number shown after the type in the above graphs indicates the lead specification.

(Note 1) If the RCP2CR is operated at the maximum load capacity for a given speed, overshoot may occur due to vibration. Therefore, when selecting a model provide an allowance of approximately 70%.

Controller

Refer to the ROBO Cylinder General Catalog for details on the controller.

Controller model

RCP2CR — C — SA6 — A — PM — O — P

Series

RCP2CR

Type

C: Internal drive-power cutoff relay type
CG: External drive-power cutoff relay type

Actuator type

Enter the (type of the actuator) — (encoder type) — (motor type)

I/O signal specification

(Blank): NPN
P : PNP

* This field may be left blank unless you require the PNP specification.

Power supply voltage

O: DC24V

