

Rotary-Type Robo Cylinder

RCP2-RT

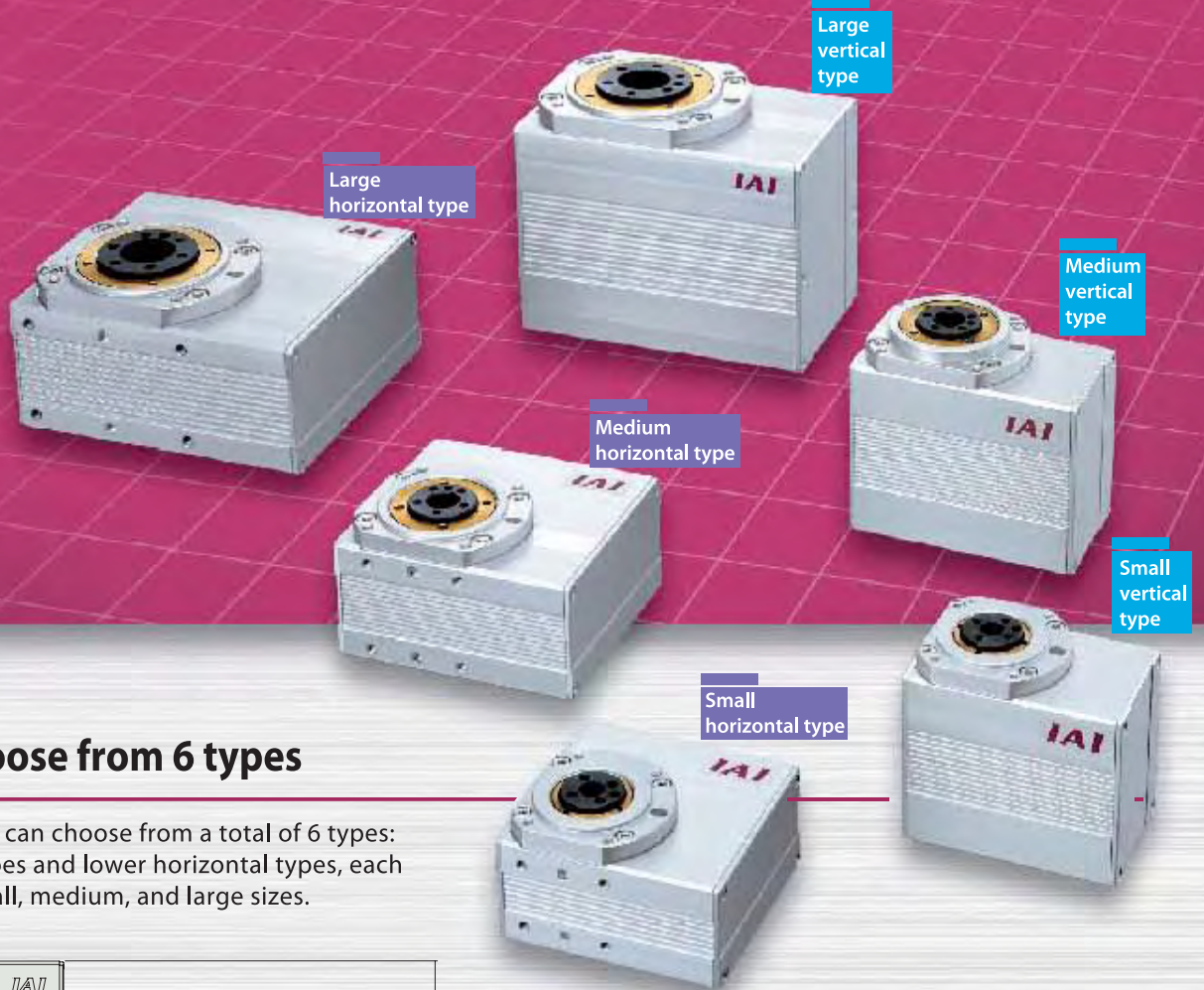

Now with the addition of the small and large types, our line-up is even stronger



1 Choose from 6 types

Now customers can choose from a total of 6 types: slim vertical types and lower horizontal types, each available in small, medium, and large sizes.

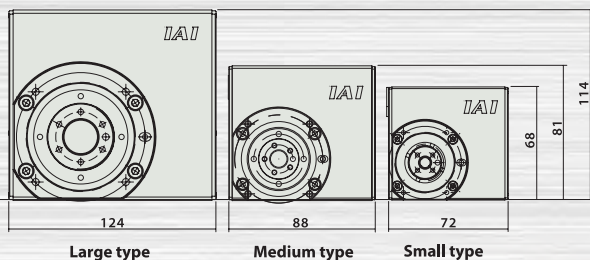

4 High-precision positioning

The output axis of the horizontal type has a hollow structure, so wires from devices installed along the output axis can be passed through it.

(*2) The small model is ± 0.05 degrees.

2 Hollow structure

The output axis of the horizontal type has a hollow structure, so wires from devices installed along the output axis can be passed through it.



3 Multiple rotation specifications

All models have multiple rotation specifications that allow rotations exceeding 360 degrees. They can be operated in the same rotational direction, like a conveyor (*1).

(*1) One rotation is within ± 360 degrees.

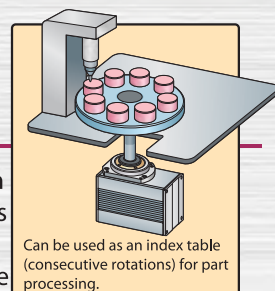

5 Can use up to 1500 positions

If a PSEL controller is used, up to 1500 positions can be used. (*3)

Customers can choose from the following controller types: positioner, serial communication, pulse line, electromagnetic valve, and program types.

(*3) Please note that the maximum number of positions varies depending on the controller



Specifications

Type	Small				Medium				Large				
	Vertical		Horizontal		Vertical		Horizontal		Vertical		Horizontal		
Shape	RTBS (standard specifications)		RTCS (standard specifications)		RTB (standard specifications)		RTC (standard specifications)		RTBB (standard specifications)		RTCB (standard specifications)		
Type	RTBSL (multiple rotation specifications)		RTCSL (multiple rotation specifications)		RTBL (multiple rotation specifications)		RTCL (multiple rotation specifications)		RTBBL (multiple rotation specifications)		RTCBL (multiple rotation specifications)		
Speed reduction ratio	1/30	1/45	1/30	1/45	1/20	1/30	1/20	1/30	1/20	1/30	1/20	1/30	
Operating range	Degrees												
Reverse rotation specifications	Standard specifications: 330 degrees. Multiple rotation specifications: ±9999 degrees (*1)												
Max. torque (*2)	Standard specifications: none. Multiple rotation specifications: yes												
Max. operating speed (*3)	N • m	0.24	0.36	0.24	0.36	1.1	1.7	1.1	1.7	3	4.6	3	4.6
Repeat stop precision (*4)	Degrees/sec	400	266	400	266	600	400	600	400	600	400	600	400
Backlash	Degrees	±0.05				±0.01				±0.01			
Allowable thrust load (*5)	Degrees	±0.1				±0.1				±0.1			
Allowable load moment (*5)	N	30				50				200			
Allowable load moment (*5)	N • m	3.6				3.9				17.7			
Detection method	Electromagnetic encoder (incremental)												
Origin point detection method	Standard specifications: mechanical stopper method. Multiple rotation specifications: proximity sensor method												
Precision to restore to the original point	Degrees	Standard specifications: Within ±0.05 Multiple rotation specifications: Within ±0.05				Standard specifications: Within ±0.01 Multiple rotation specifications: Within ±0.05				Standard specifications: Within ±0.01 Multiple rotation specifications: Within ±0.03			
Usage environment	Temperature: 0-40°C, Humidity: 20-85% RH or less (no condensation)												
Outer dimensions of main unit (thickness x width x height)	mm	45×72×70		68×72×45		50×88×83.5		81×88×55		76×124×107		114×124×68	
Mass of main unit	kg	0.52		0.48		0.86		0.92		2.3		2.2	
Motor cable type	CB-PCS-MPA□□□□ (Cable with motor and encoder in one) CB-RCP2-MA□□□□ * The standard motor cable is a robot cable.												
Encoder cable type	CB-RCP2-PB□□□□ (CB-RCP2-PB-RB) (*1)												

- (*1) Multiple rotation specifications: in normal mode, it is possible to move up to ± 9999 degrees of consecutive travel.
 (*2) Maximum torque changes depending on the speed. (See the front and back sides of the model selection document)
 (*3) The maximum speed changes depending on the load.
 (*4) Shows the repeat positioning precision from one direction.
 (*5) If loads exceeding these values are used, it may cause damage or shorten the lifespan of the unit. (See the diagram on the right for the direction of force)
 (*6) Robot cable types are inside ().

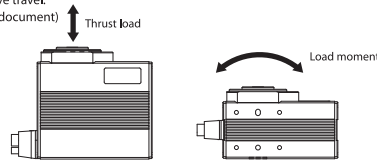

Type criteria

□ Type categories

RCP2	—	□	—	I	—	□	—	□	—	□	—	P1	—	□	—	□
Series	—	Type	—	Encoder type	—	Motor type	—	Speed reduction ratio	—	Vibration angle	—	Applicable controller	—	Cable length	—	Options
		RTBS : Small vertical standard		I: Incremental		20P: Pulse motor 20 size		20: Speed reduction ratio 1/20		330: 330 degrees		P1: PCON		N: None		SA: Shaft adapter
		RTBSL : Small vertical multiple rotation				28P: Pulse motor 28 size		30: Speed reduction ratio 1/30		360: 360 degrees (Multiple rotation)		PSEL		P: 1 m		TA: Table adapter
		RTCS : Small horizontal standard				35P: Pulse motor 35 size		45: Speed reduction ratio 1/45						S: 3 m		
		RTCSL : Small horizontal multiple rotation												M: 5 m		
		RTB : Medium vertical standard												X □ □ : Length designation		
		RTBL : Medium vertical multiple rotation												R □ □ : Robot cable		
		RTC : Medium horizontal standard												* Robot cables are standard for small types.		
		RTCL : Medium horizontal multiple rotation														
		RTBB : Large vertical standard														
		RTBBL : Large vertical multiple rotation														
		RTCB : Large horizontal standard														
		RTCBL : Large horizontal multiple rotation														

Type

Type	Type	Type	
Small	Vertical	Standard specifications	RCP2-RTBS-I-20P-30(45)-330-P1
		Multiple rotation specifications	RCP2-RTBSL-I-20P-30(45)-360-P1
	Horizontal	Standard specifications	RCP2-RTCS-I-20P-30(45)-330-P1
		Multiple rotation specifications	RCP2-RTCSL-I-20P-30(45)-360-P1
Medium	Vertical	Standard specifications	RCP2-RTB-I-28P-20(30)-330-P1
		Multiple rotation specifications	RCP2-RTBL-I-28P-20(30)-360-P1
	Horizontal	Standard specifications	RCP2-RTC-I-28P-20(30)-330-P1
		Multiple rotation specifications	RCP2-RTCL-I-28P-20(30)-360-P1
Large	Vertical	Standard specifications	RCP2-RTBB-I-35P-20(30)-330-P1
		Multiple rotation specifications	RCP2-RTBBL-I-35P-20(30)-360-P1
	Horizontal	Standard specifications	RCP2-RTCB-I-35P-20(30)-330-P1
		Multiple rotation specifications	RCP2-RTCBL-I-35P-20(30)-360-P1

Cable Length

Type	Type
Standard type	P (1m)
	S (3m)
	M (5m)
Special lengths	X06 (6m) -X10 (10m)
	X11 (11m) -X15 (15m)
	X16 (16m) -X20 (20m)
Robot cable	R01 (1m) -R03 (3m)
	R04 (4m) -R05 (5m)
	R06 (6m) -R10 (10m)
	R11 (11m) -R15 (15m)
	R16 (16m) -R20 (20m)

Options

Name	Option Symbol
Reverse rotation specifications	NM
Shaft adapter	SA
Table adapter	TA

*Option pricing is the same for small, medium, and large types.

Applicable Controller

Name	Type
Positioner type	PCON-C-□I-NP-2-0
Safety category compatible type	PCON-CG-□I-NP-2-0
Electromagnetic valve type	PCON-CY-□I-NP-2-0
Pulse line type (differential)	PCON-PL-□I-NP-2-0
Pulse line type (open collector)	PCON-PO-□I-NP-2-0
Serial type	PCON-SE-□I-N-0-0
Field network type	RPCON-□
Program control type	PSEL-C-1-□I-NP-2-0

* The □ in the above model designations denote numbers representing the motor of the main rotary unit.

Example: When operating a large type: PCON-C-35PI-NP-2-0

Medium vertical type



Note:

* The diagonal lines on the right top view show the rotating areas.

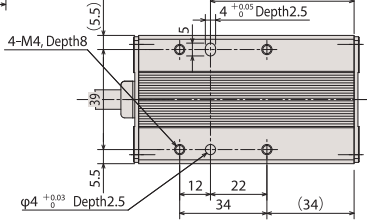
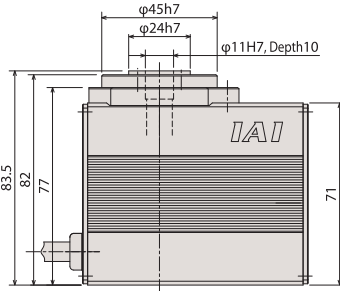
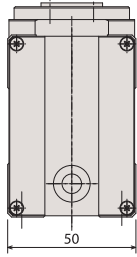
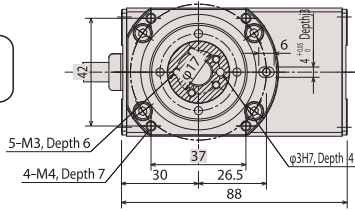

CAD drawing can be downloaded from the website.

www.intelligentactuator.com

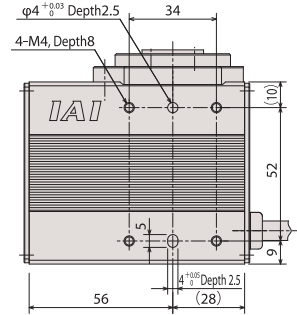

Note:

The position on the left top view is the origin point position.
 * When going back to the origin point, the unit rotates from the current position to a position 1 degree to the left, so be careful of interference in the surrounding area.
 * The operating range is 330 degrees rotating to the right, looking from the top.

Mass (kg)	0.86
-----------	------

Medium horizontal type



Note:

The diagonal lines on the right top view show the rotating areas.

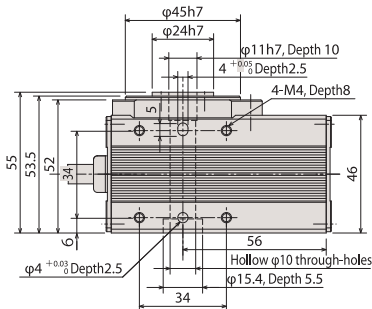
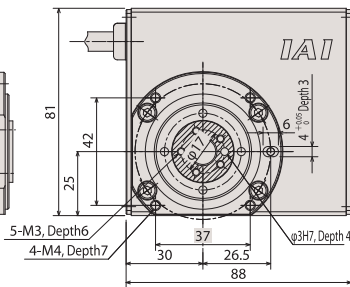
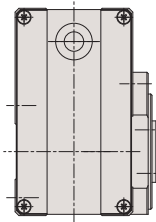
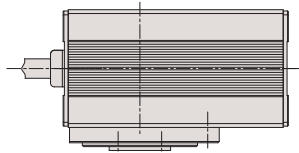

CAD drawing can be downloaded from the website.

www.intelligentactuator.com

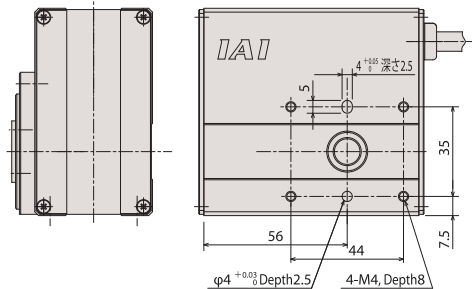

Note:

The position on the left top view is the origin point position.
 * When going back to the origin point, the unit rotates from the current position to a position 1 degree to the left, so be careful of interference in the surrounding area.
 * The operating range is 330 degrees rotating to the right, looking from the top.

Mass (kg)	0.92
-----------	------

Large vertical type

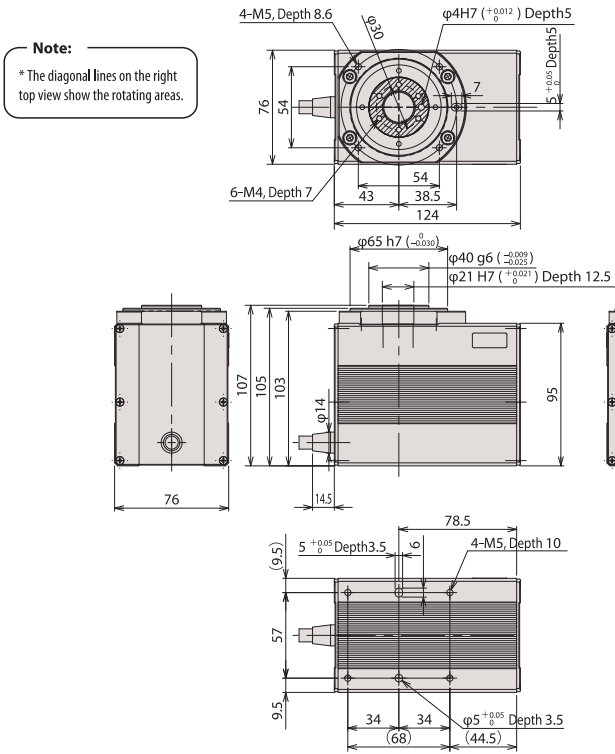

CAD drawing can be downloaded from the website. www.intelligentactuator.com

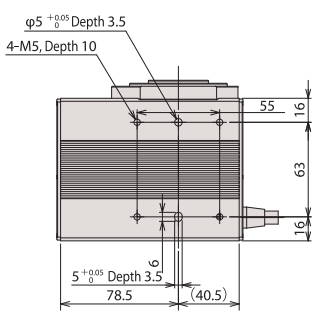

Note:
The position on the left top view is the origin point position.
 * When going back to the origin point, the unit rotates from the current position to a position 1 degree to the left, so be careful of interference in the surrounding area.
 * The operating range is 330 degrees rotating to the right, looking from the top.

Mass (kg)	2.3
-----------	-----

Large horizontal type

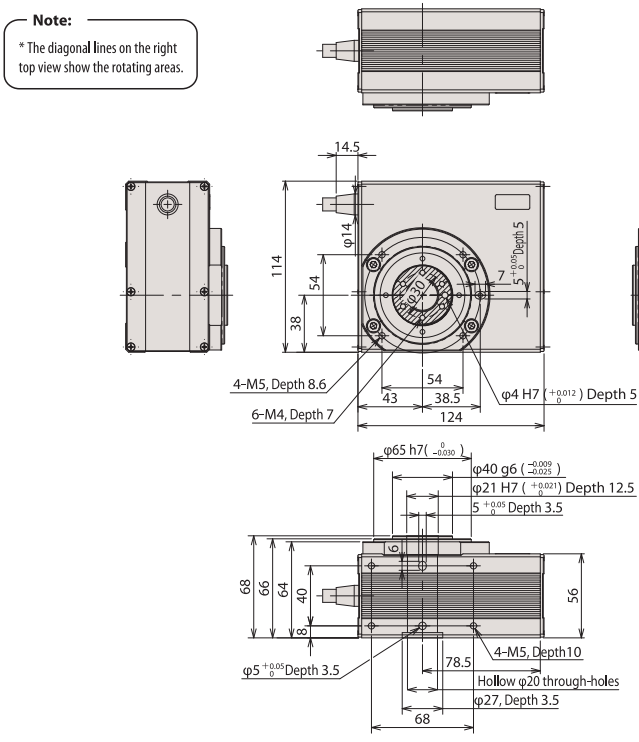

CAD drawing can be downloaded from the website. www.intelligentactuator.com

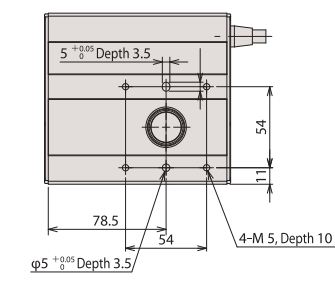

Note:
The position on the left top view is the origin point position.
 * When going back to the origin point, the unit rotates from the current position to a position 1 degree to the left, so be careful of interference in the surrounding area.
 * The operating range is 330 degrees rotating to the right, looking from the top.

Mass (kg)	2.2
-----------	-----

Options

Shaft adapter

□ Model SA

This is a shaft-shaped adapter for attaching jigs, etc. to the rotating areas of the rotary type unit.

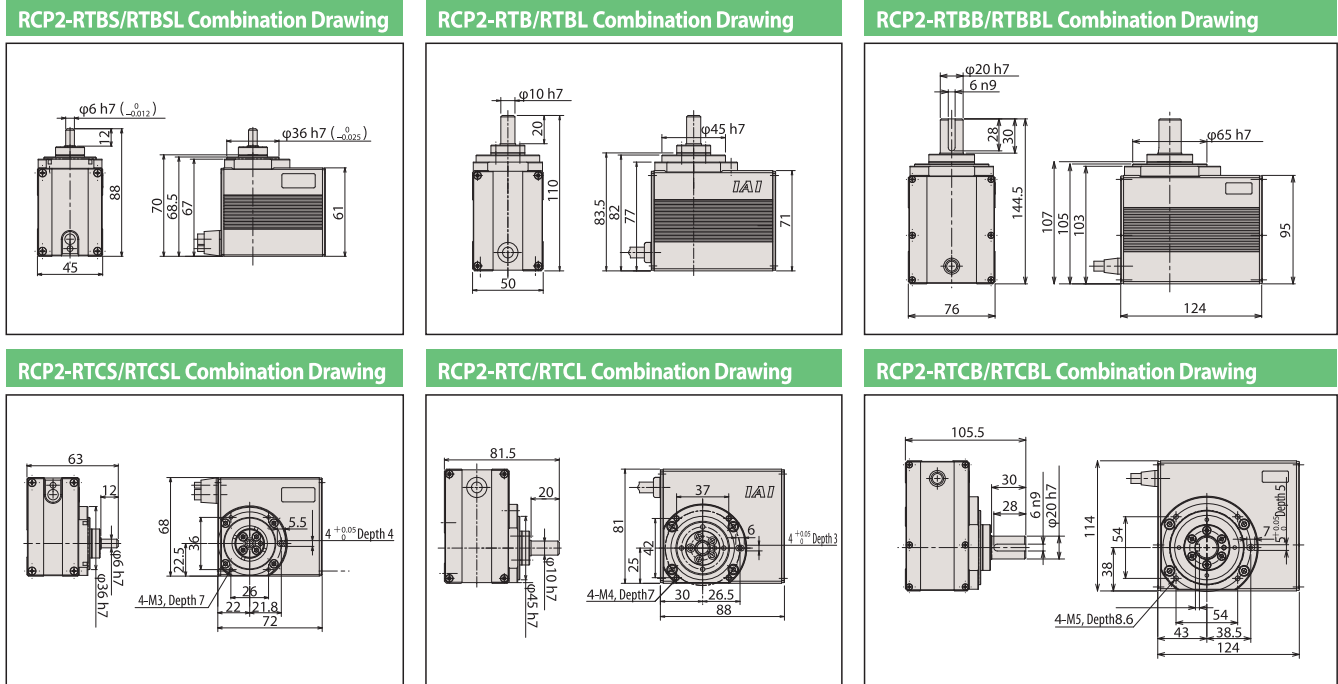
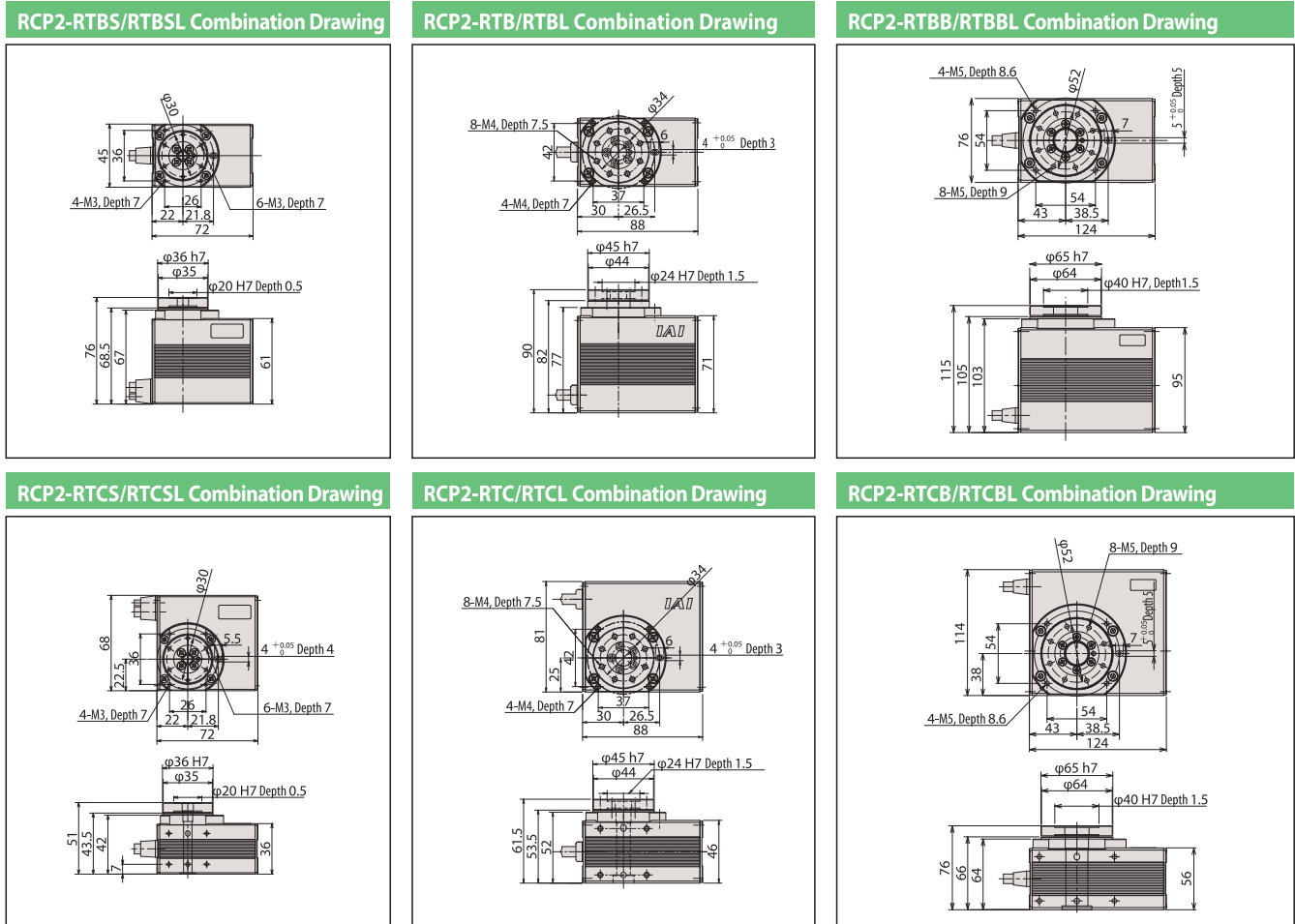

Table adapter

□ Model TA

This is a table-shaped adapter for attaching jigs, etc. to the rotating areas of the rotary-type unit.



Selection goals

Output torque

Output torque decreases as rotational speed increases.

* Please use the bottom graph to verify whether you can get enough necessary speed torque for operation.

Small vertical type RTBS/RTBSL Small horizontal type RTC/RTC SL

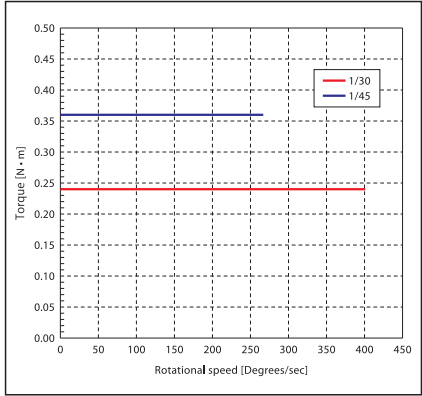

Medium vertical type RTB/RTBL Medium horizontal type RTC/RTCL

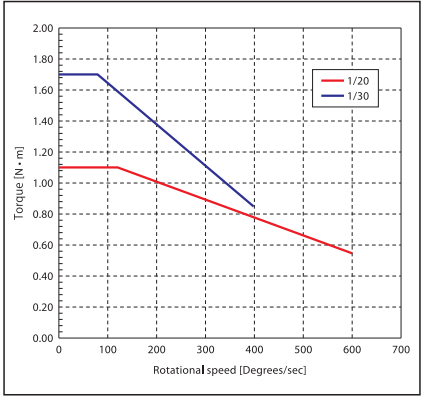

Large vertical type RTBB/RTBBL Large horizontal type RTCB/RTCLB

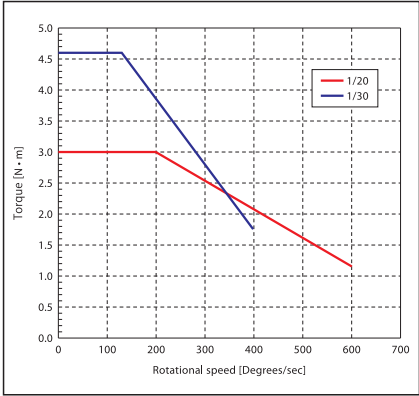

Allowable inertial moment

The allowable inertial moment for workpieces that can be rotated differs based on the rotational speed.

* Please verify the operating conditions and inertial moment of workpieces that can be rotated.

Small vertical type RTBS/RTBSL Small horizontal type RTC/RTC SL

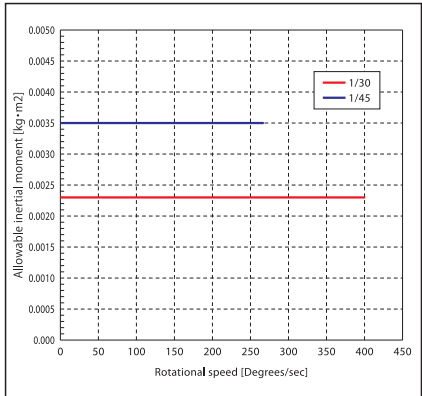

Medium vertical type RTB/RTBL Medium horizontal type RTC/RTCL

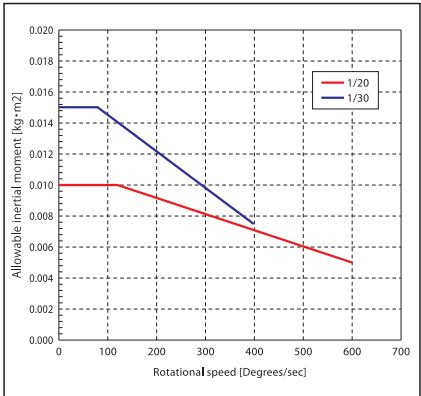

Large vertical type RTBB/RTBBL Large horizontal type RTCB/RTCLB

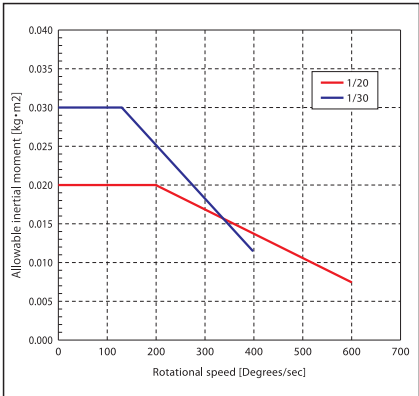

Inertial moment

Inertial moment expresses the amount of inertia in the rotational motion, and is equivalent to the mass for linear motion.

The larger the inertial moment, the more difficult it is for that object to move and stop.

That is, when choosing a rotary-type unit, whether or not the inertial moment (of the object that can be rotated) can be controlled or not is a decision-making factor.

* This type can be used if the inertial moment found in the calculation is smaller than the allowable inertial moment of the rotary type.

• Calculation method for inertial moment for main shapes

J: Inertial moment (kg · m²)/M: Mass (kg)/r: Radius (m)/a.

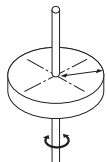

(1) Cylinder (includes thin disc)
Position of axis of rotation: center axis

$$J = M \cdot \frac{r^2}{2}$$

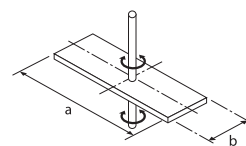

(2) Thin rectangular plate (rectangular solid)
Position of axis of rotation: Pass one end perpendicular to the plate.
(Same, if using a rectangular solid with a thick plate)

$$J = M \cdot \frac{a^2 + b^2}{12}$$

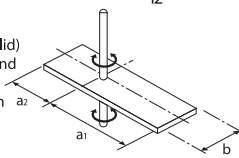

(3) Thin rectangular plate (rectangular solid)
Position of axis of rotation: Pass one end perpendicular to the plate.
M1: Mass (kg) on a1 side
M2: Mass (kg) on a2 side

$$J = M_1 \cdot \frac{4a_1^2 + b^2}{12} + M_2 \cdot \frac{4a_2^2 + b^2}{12}$$

