

# ROBO NET

## ROBONET Extension Unit

---

Addendum to Manual First Edition

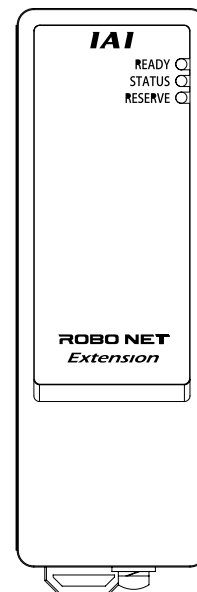

**IAI Industrieroboter GmbH**

Ober der Röth 4

D-65824 Schwalbach / Taunus

Phone: 06196/8895-0 / Fax: 06196/8895-24

E-Mail: [info@iai-gmbh.de](mailto:info@iai-gmbh.de)

Internet: <http://www.eu.iai-gmbh.de>

Document BA\_extension-ROBONET-EU-E

ROBONET Extension Unit

Version 1 E, October 2007



## 1. Overview

Under normal circumstances, the ROBONET system consists of a Gateway R unit in the leftmost slot and RPCON or RACON controller units installed side by side, adjacent to the Gateway R unit. However, due to the width of the control panel or other physical limitations, it may not be possible to arrange the modules in a single row. In that case, the (optional) Extension unit can be used to arrange the modules into several rows (multi-row arrangement). The controller units are normally RPCON or RACON units, but the Extension unit allows SCON (positioner mode) or PCON-CF units to be connected to the ROBONET system (via external SIO link).

(1) ROBONET system in a multi-row arrangement

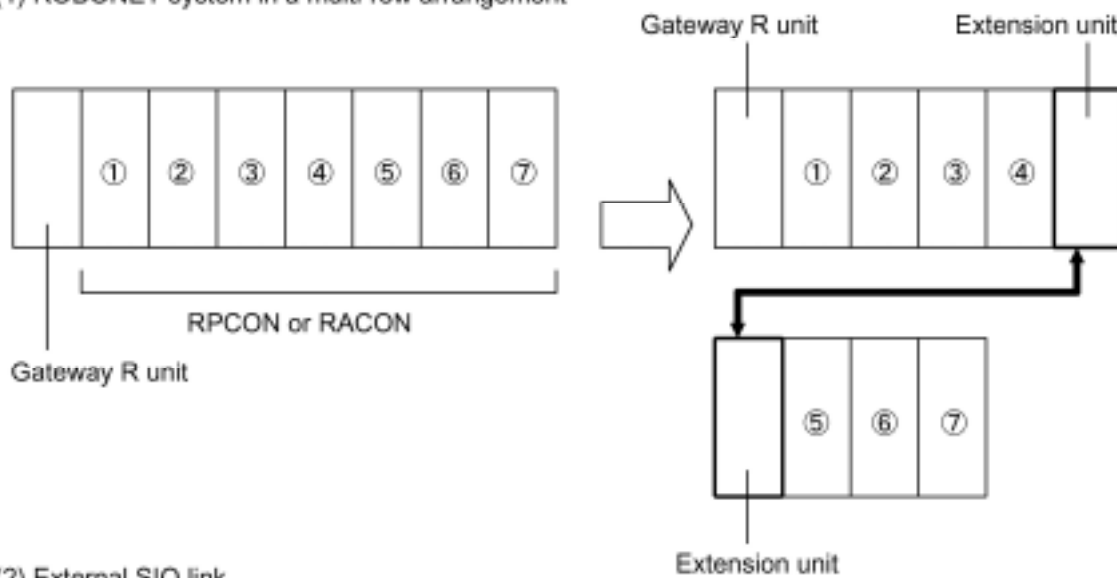

(2) External SIO link

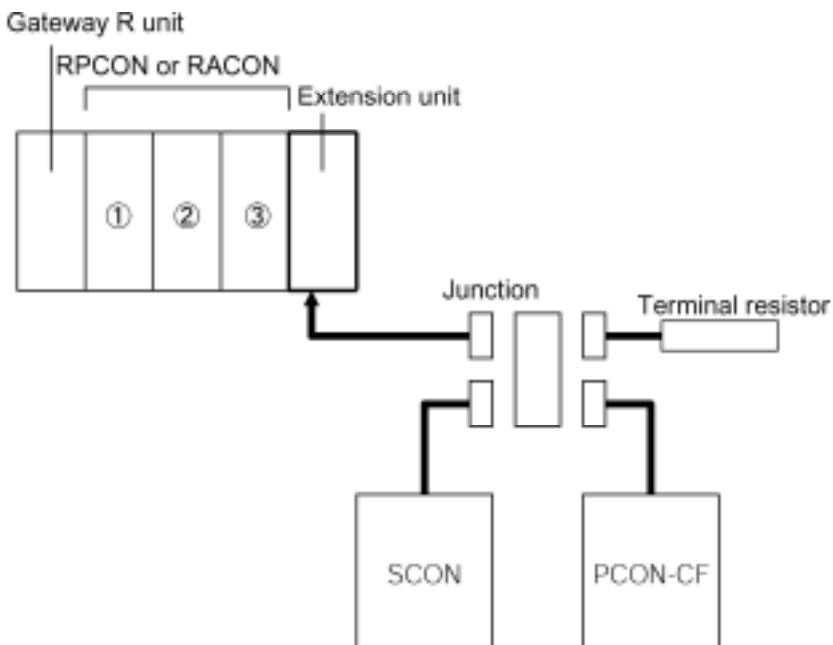

## 2. Specifications

Type	REXT (Main unit)	
Power supply	DC24V±10%	
Current consumption	Max. 200mA	
Environmental conditions	Ambient operating temperature	0~40°C
	Ambient operating humidity	Max. 95% RH (non-condensing)
	Operating ambience	Free of corrosive gases and dust
	Storage temperature	0~40°C
	Storage humidity	Max. 95% RH (non-condensing)
	Vibration resistance	XYZ directions: 10~57Hz half amplitude 0.035 mm (continuous) 0.075 mm (intermittent) 57~150Hz 4.9m/s <sup>2</sup> (continuous) 9.8m/s <sup>2</sup> (intermittent)
	Impact resistance	XYZ directions: 147 mm/s <sup>2</sup> 11 ms half sign-wave pulse
Protection degree:	IP20	
Weight	140g (main unit only)	
External dimensions	34W×100H×73.3D mm	

## 3. Product configuration

Name	Type	Contents	Application	Figure
ROBONET Extension unit	REXT	<ul style="list-style-type: none"> <li>Main unit x 1</li> <li>Power supply connection plate x 2</li> <li>Communication connection circuit board x 1</li> </ul>	<ul style="list-style-type: none"> <li>ROBONET multi-row arrangement</li> <li>External SIO link</li> </ul>	Fig.1
ROBONET Extension set A	REXT-SIO	<ul style="list-style-type: none"> <li>Main unit x 2</li> <li>Power supply connection plate x 2</li> <li>Communication connection circuit board x 1</li> <li>ROBONET Extension A cable (standard 1 m)</li> </ul>	Multi-row arrangement set	Fig.2
ROBONET Extension set B	REXT-CTL	<ul style="list-style-type: none"> <li>Main unit x 1</li> <li>Power supply connection plate x 2</li> <li>Communication connection circuit board x 1</li> <li>ROBONET Extension B cable (standard 1 m)</li> </ul>	External SIO link set	Fig.3
ROBONET Extension A cable	CB-REXT-SIO□□□		Cable for interconnecting ROBONET Extension units	Fig.4
ROBONET Extension B cable	CB-REXT-CTL□□□		Cable to connect the external SIO link	Fig.5

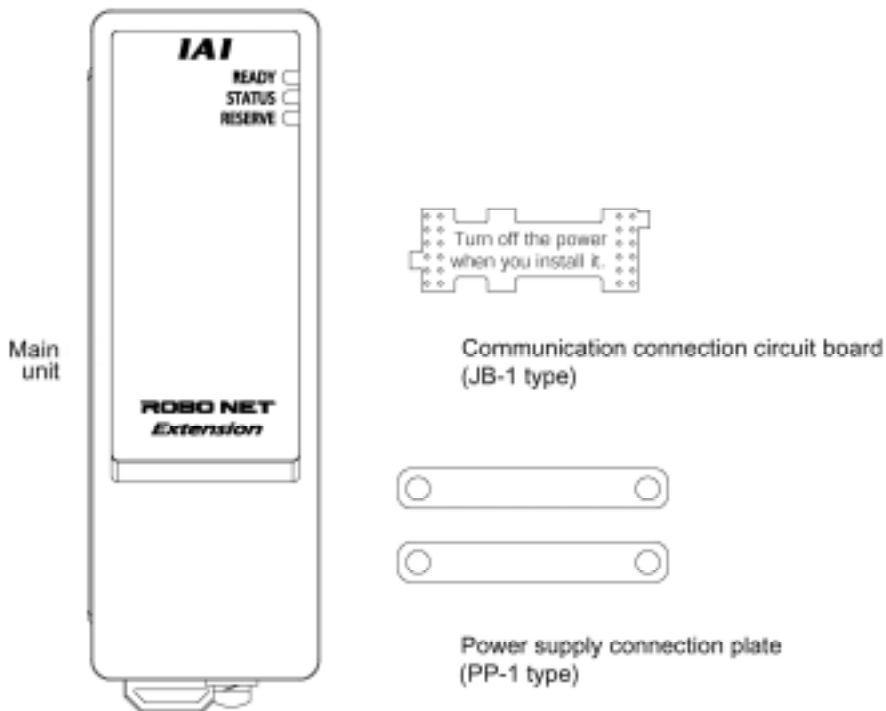

Fig.1 ROBONET Extension unit (REXT)

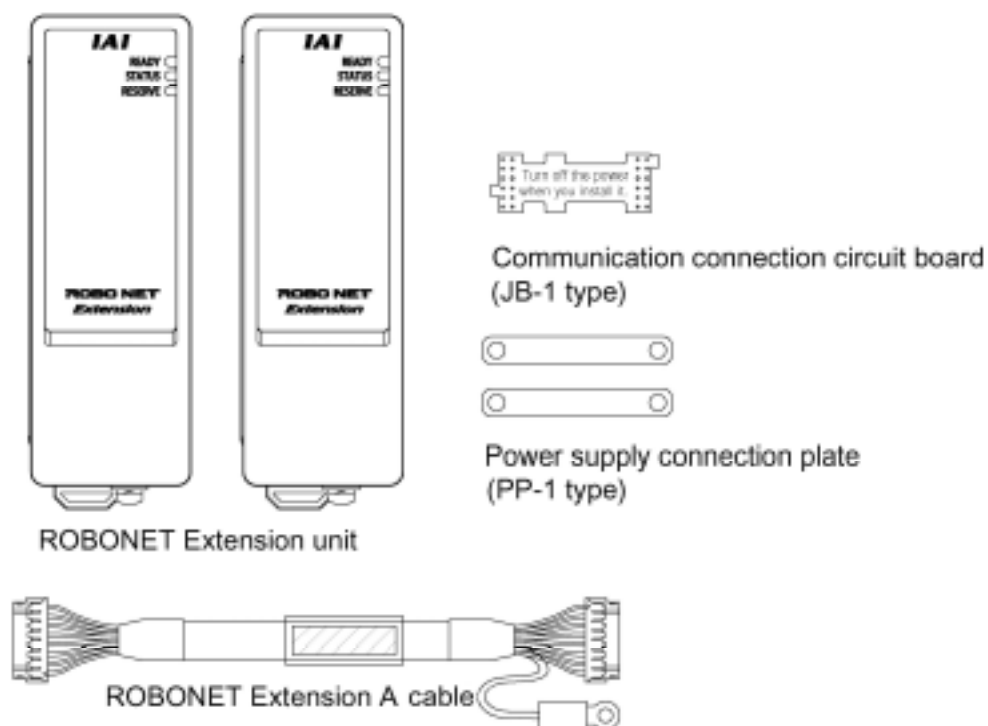

Fig.2 ROBONET Extension set A (REXT-SIO)

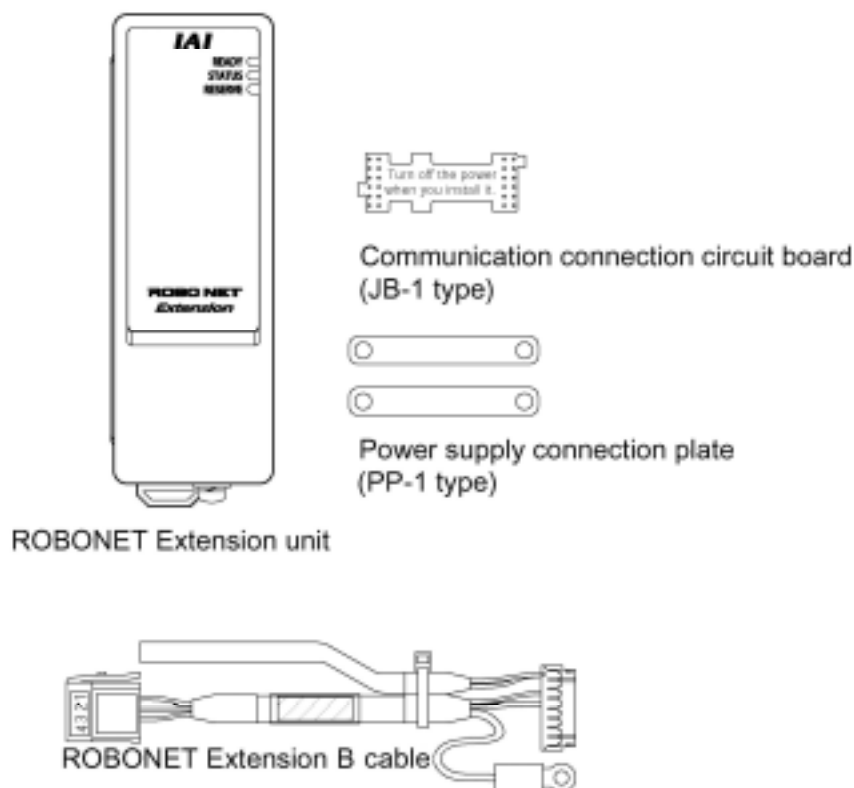
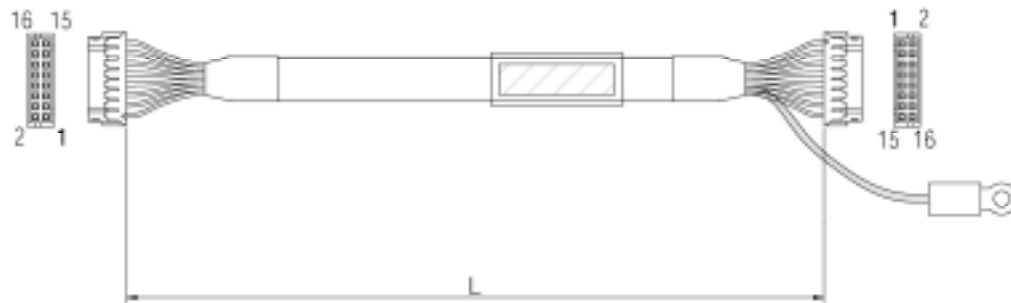
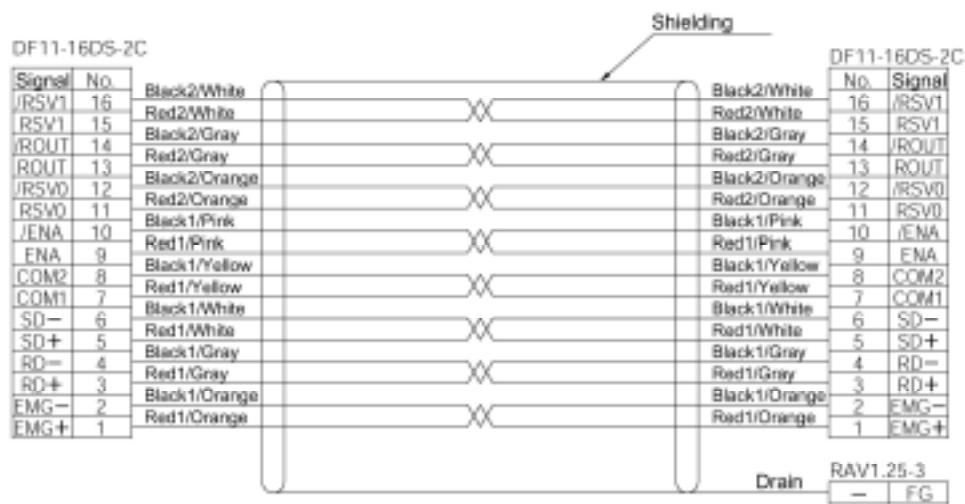

Fig.3 ROBONET Extension set B (REXT-CTL)



**Harness assembly**



Wiring color explanation: dot color, number/insulation color  
**Connection diagram**

※□□□ is the cable length (L)  
Example: 010 = 1 m

**Fig.4 ROBONET Extension A cable (CB-REXT-SIO□□□)**

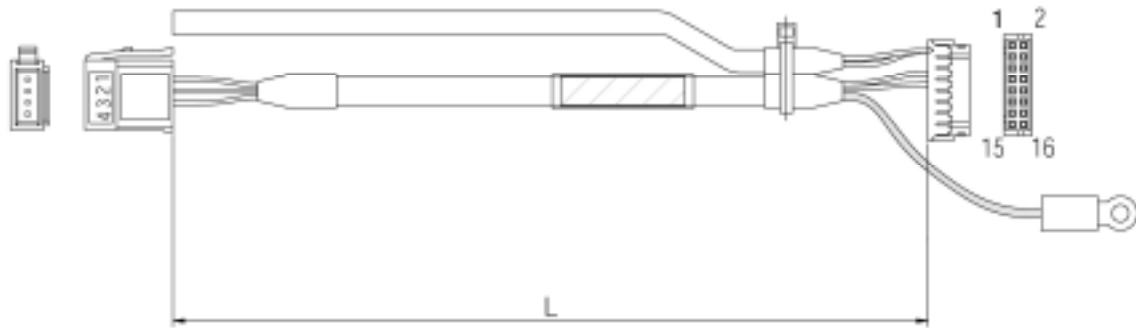

Harness assembly

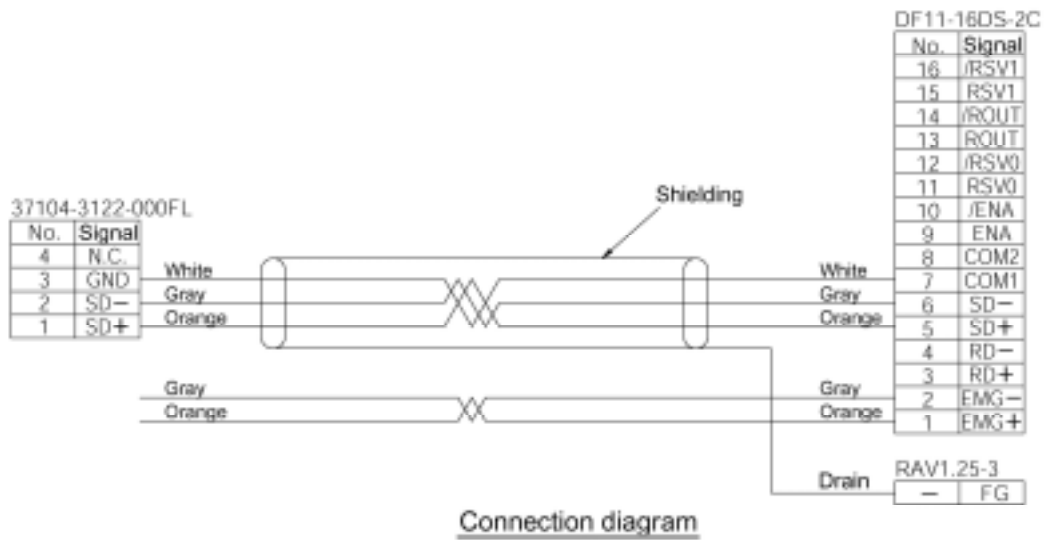

Connection diagram

※□□□ is the cable length (L)

Example: 010 = 1 m

Fig.5 ROBOTNET Extension B cable (CB-REXT-CTL□□□)

## 4. Part names and external dimensions

### 4.1 Part names

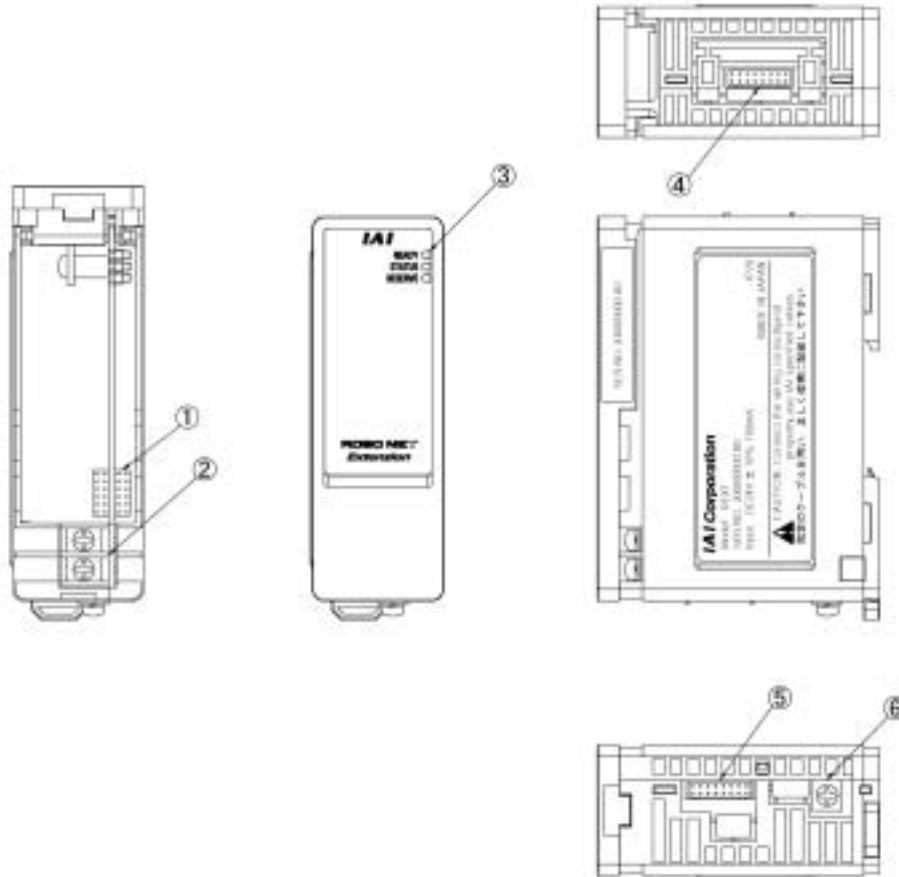

Number	Name	Description
	ROBONET communication connector	Communication connector for connecting units in the same row. Connect with the ROBONET communication connection circuit board (JB-1).
	Power supply terminal block	Use this input terminal block to connect DC 24V to the unit. The top terminal is for the +24V, the bottom terminal is for the 0V connection. Use a maximum of 6 mm wide M3 round terminals to connect the power supply wires. Use the power supply connection plates (PP-1) for interconnecting units in the same row.
	Indicator LED READY	Displays the status of the internal power (5V) • Green light : Normal      • No light : internal power failure
	STATUS	Displays the connection status of connectors and . • Green light : Normal (only one of the connectors is connected) • Red light : Error (both connectors are connected) • No light : Error (none of the connectors are connected) If the external SIO link connection is used, this LED is not lit.
	RESERVE	Not used Normally not lit

Number	Name	Description
	Connector to upstream units	This connector is used to connect to the upstream (upper row) units via the ROBONET Extension A cable (CB-REXT-SIO).
	Connector to downstream units	This connector is used to connect to the downstream (lower row) units via the ROBONET Extension A cable (CB-REXT-SIO). If the external SIO link connection is used, then the ROBONET Extension B cable (CB-REXT-CTL) should be used.
	FG terminal block	Use this terminal block to connect the ground wire (M3 round terminal). Use this terminal block to connect the shield wire of the ROBONET Extension A cable (CB-REXT-SIO) or the ROBONET Extension B cable (CB-REXT-CTL).

## 4.2 External dimensions

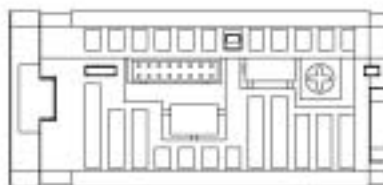
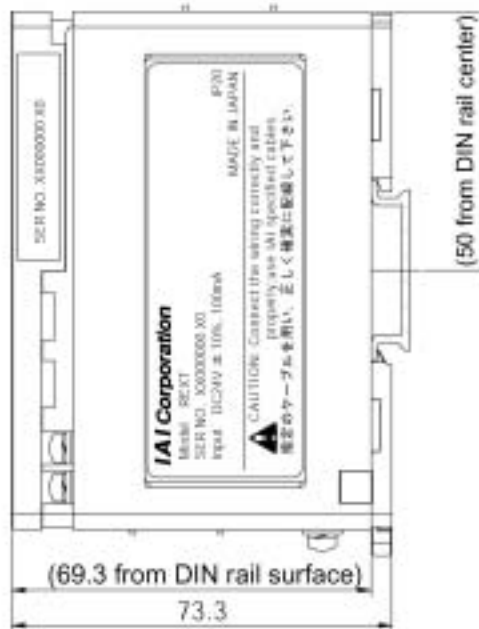
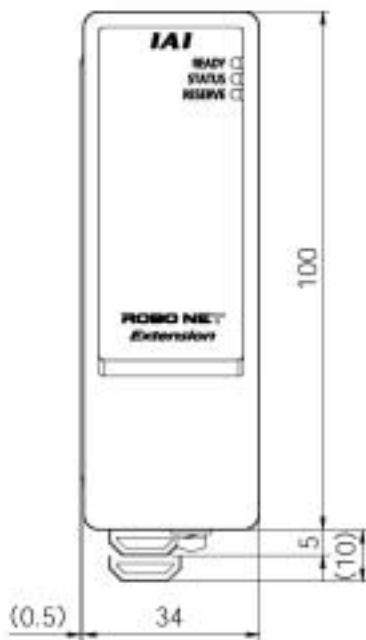
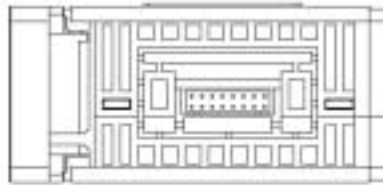

## 5. Connection procedures

### 5.1 ROBONET system in a multi-row arrangement

The illustration on the right shows an example of a multi-row arrangement.

- (1) The units are connected to a DIN rail.
- (2) Install the Extension unit connecting downstream (to the lower row) in the rightmost position.  
(Extension units , )
- (3) Install the Extension unit connecting upstream (to the upper row) in the leftmost position.  
(Extension units , )
- (4) Connect the upstream (upper row) and downstream (lower row) Extension units using the ROBONET Extension A cable (CB-REXT-SIO), and connect the grounding wire with an M3 round terminal to the FG terminal block of the upstream Extension unit.  
(Extension units , )  
Connect the FG terminals of the downstream Extension unit ( , ) to the ground terminal of the control panel, the same way as the Gateway R unit is connected.
- (5) The terminal resistor board that is enclosed with the Gateway R unit should be installed on the rightmost unit of the last downstream row (bottom row).
- (6) Connect the Extension unit to the adjacent unit using the enclosed power supply connection plate and the communication connection circuit board.
- (7) Connect the power supply (+24V, 0V) to the leftmost unit of each row. Make sure the power-up time is the same for all rows.

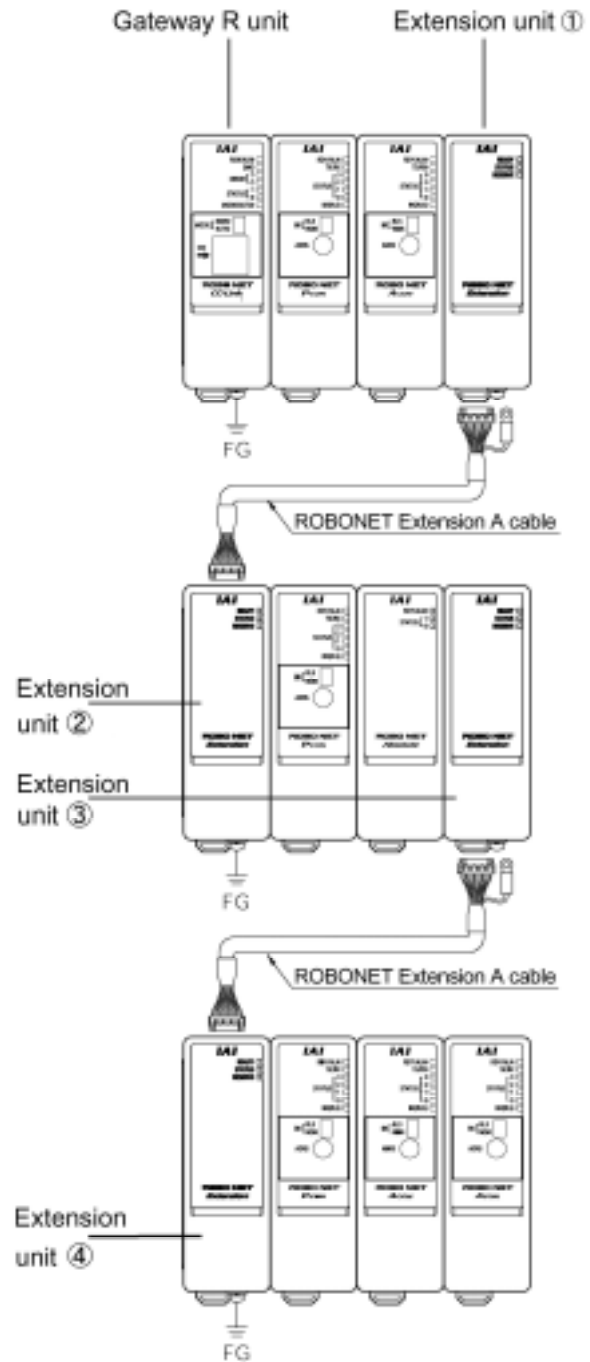

- Warning:**
1. The 0V of the supply power (+24V, 0V) to each row should be common.
  2. The RABU unit (Simple absolute R unit) paired with the RPCON or RACON unit must be installed in the same row.

## 5.2 External SIO link

The illustration on the right shows an example of the external SIO link.

The first row and the second row are in a multi-row arrangement, where the SCON or the PCON-CF is connected to the last unit of the second row (Extension unit ) via SIO link.

- (1) The various units are connected to a DIN rail.
- (2) The first and second rows of the multi-row arrangement are the same as under 5.1, please refer to the explanation presented there.
- (3) Connect the Extension unit to the adjacent unit using the enclosed power supply connection plate and the communication connection circuit board.
- (4) Place the Extension unit that is used for the external SIO link (Extension unit ) in the last slot of the last downstream row (bottom row). Connect the ROBONET Extension B cable (CB-REXT-CTL) to the downstream connector of the Extension unit. Connect the grounding wire with an M3 round terminal to the FG terminal block.
- (5) Connect the e-CON side of the Extension B cable to the 4-way junction.
- (6) Use the optional controller link cable (CBRCB-CTL002) to connect the SCON or the PCON-CF to the 4-way junction. Use the following accessories that are supplied with the controller link cable (CBRCB-CTL002) to make the connections illustrated on the right.
  - 4-way junction (AMP 5-1473574-4) x 1
  - e-CON connector (AMP 4-1473562-4) x 1
  - Terminal resistor 220Ω (with e-CON connector) x 1

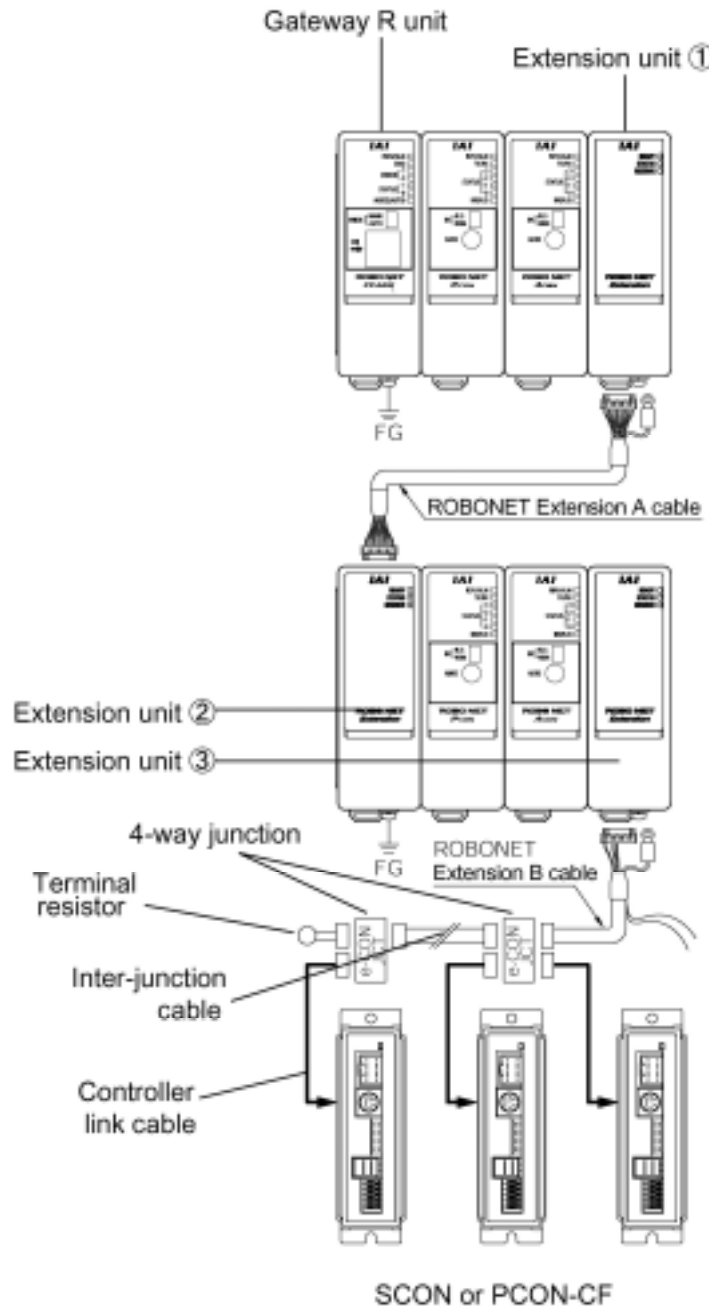

- (7) There is no need to use the supplied terminal resistor with the Gateway R unit. (Do not install it on the ROBONET controller.)  
Install the 220Ω terminal resistor supplied with the controller link cable to the last 4-way junction of the SIO link.

### <Creating the intra-junction cable>

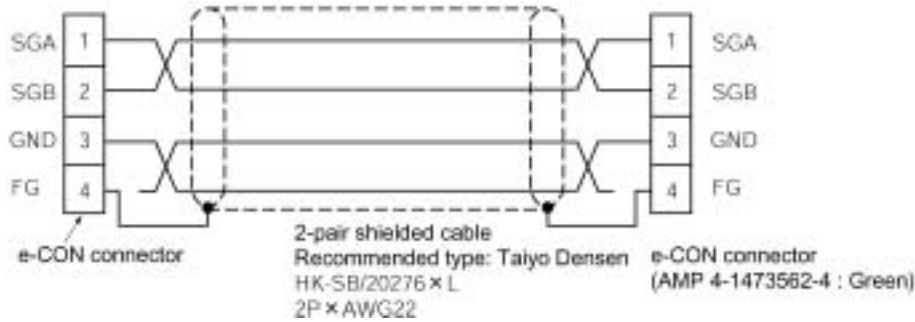

Strip 15-20mm off of the external coating of the 2-pair shielded cable.  
 Pull the cable protector tube over the cable.  
 With the internal wire coatings intact, insert the 4 wires into the holes.  
 While the cable is inserted, compress the housing from the top.  
 Heat-treat the cable protecting tube.

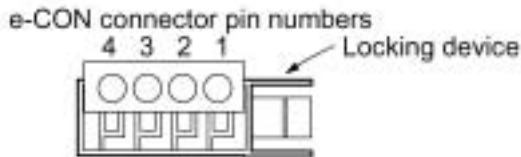
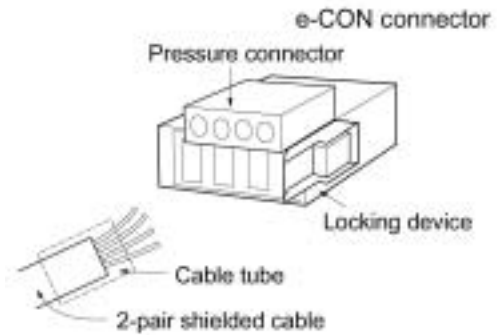

Always install a terminal resistor (220Ω, 1/4W) to the end of the main communication line (between Pin 1 and Pin 2 of the e-CON connector).

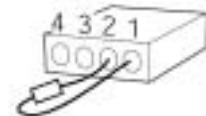

### <Controller link cable> (CB-RCB-CTL002)

This cable can be purchased separately as an optional accessory to the controller.

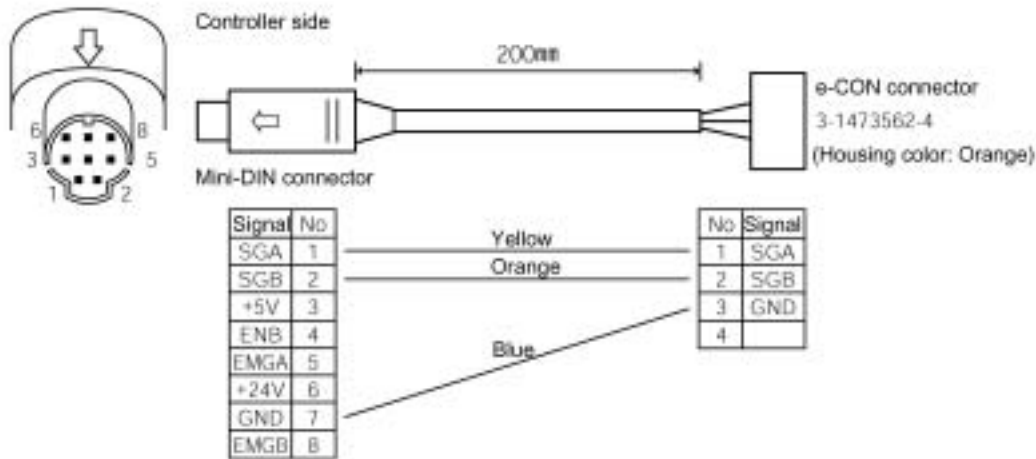

The following parts are supplied with the cable:

4-way junction	Type: 5-1473574-4	Manufacturer: AMP	x 1
e-CON connector	4-1473562-4	Manufacturer: AMP	x 1
	Compatible wire diameter including insulation: 1.35~1.6mm		
Terminal resistor	220Ω 1/4W	Supplied with the e-CON connector	x 1

## 5.3 Emergency stop circuit

The diagram below shows the emergency stop circuit for the external SIO link.

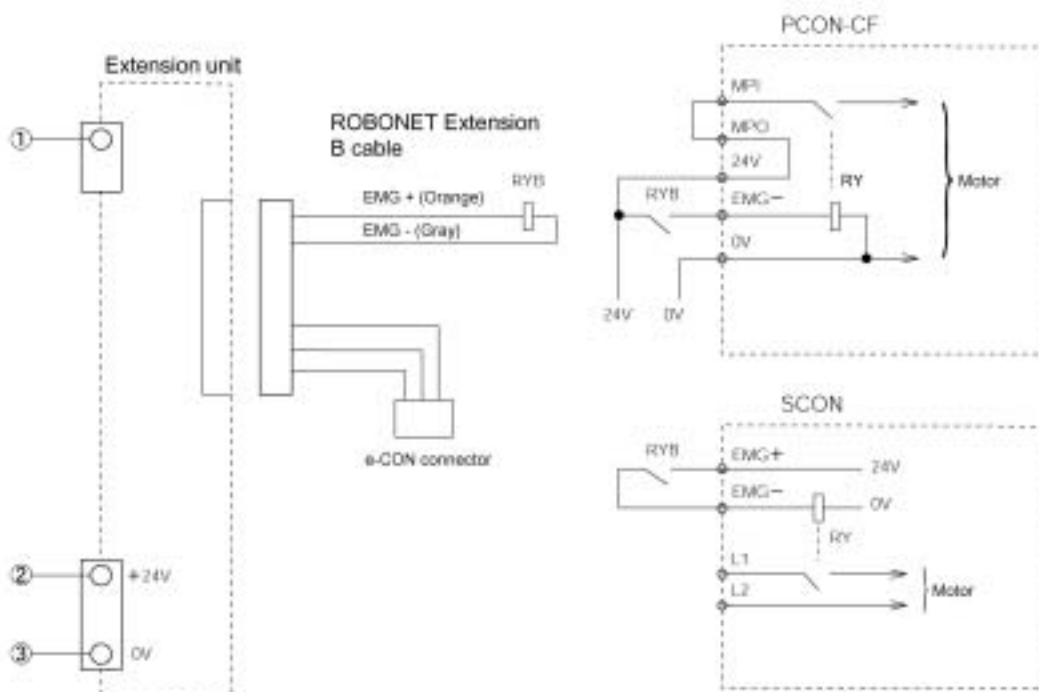
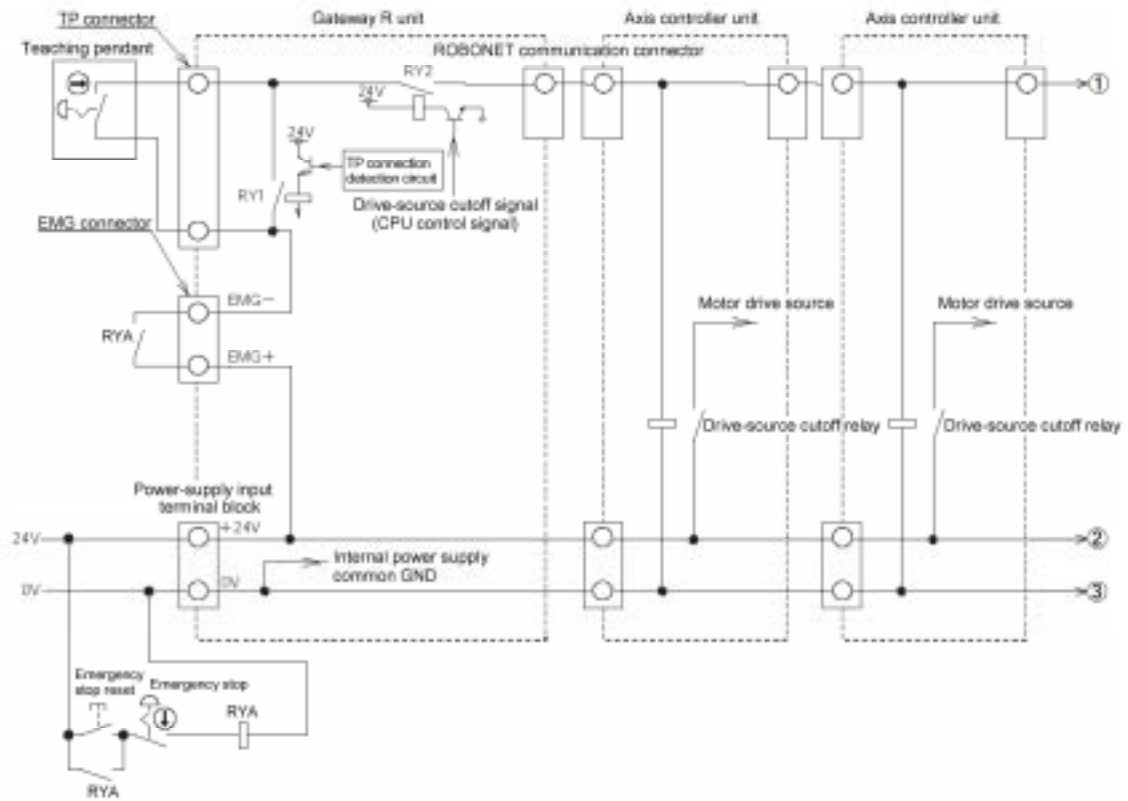



- Warning:
1. Select the RYA relay with a minimum rated contact capacity of 160mA.
  2. Select the RYB relay so the coil current rated value satisfies the following formula:  
 $10\text{mA} \times \text{No. of ROBONET controllers} + \text{RYB coil current rating} \leq 160\text{mA}$ .
  3. The 0V side of the 24V power supply of the ROBONET controller and the 0V side of the PCON-CF power supply should be common.

## 6. Other important points

The followings must be noted regarding the status of the SW1 user setting switch of the Gateway R unit:

- (1) If SW1 = OFF (TP enable switch signal disabled)

Regardless of the enable operation parameter of the Gateway parameter setting tool, the connected RPCON, RACON, PCON-CF, SCON does not respond to the TP enable switch signal.

- (2) If SW1 = ON (TP enable switch signal enabled)

When the enable operation parameter setting is "Shutdown control":

The TP enable switch becomes disabled, and the connected RPCON, RACON, PCON-CF, SCON units go into stop status (servo off → drive source cutoff).

When the enable operation parameter setting is "Servo control":

The TP enable switch becomes disabled, and the connected RPCON, RACON units go into stop status (servo off), but the PCON-CF, SCON units don't stop, they continue their operation.

## 7. SCON/PCON-CF settings and signal allocation when using the external SIO link

The SCON can only operate in positioner mode. It cannot be operated in pulse train input mode. The following settings are required for operation:

### (1) User parameters

Number	Name	Setting (change) description	SCON	PCON-CF
16	SIO communication speed	38400bps (Default value) →change to 230400bps	Yes	Yes
17	Slave transmitter activation Minimum delay time	5msec (Default value) →change to 2msec	Yes	Yes
25	PIO pattern selection	Default value 0 (Standard type) →Set to 0~3 (*See Note)	Yes	Yes
74	PIO power monitor	Default value 0 (Enabled) →change to 1 (Disabled)	Yes	No

\*Note: The 4 and 5 solenoid valve mode settings cannot be used. The maximum number of positions that can be registered depends on the selected mode.

### (2) Piano switch (SCON only)

Set the SCON to positioner mode by turning the first piano switch OFF on the front panel.

### (3) Mode switch

Set the mode switch on the front panel of the SCON/PCON-CF to AUTO.

### (4) Signal allocation

The signal allocation of the SCON/PCON-CF is the same as of the RPCON/RACON. Refer to the specifications in the ROBONET user manual.

### (5) Use the rotary switch for setting the axis number.



