



RS

Rotary System Series



Rotary Actuator

Features

- We offer 6 basic models and 11 different types of rotary actuator to choose from.
4 DC servo models
2 AC servo models
* Speed reduction ratio of 1/100, 1/50 (1/10)
- The RS Series rotary actuator is compact in design and lightweight.
- The RS Series can be used as a Theta axis together with our AS and FS Series actuators in a multi-axis positioning system.
- When used with our M-SEL (standard DC servo version) or M-ACSEL (AC servo version) controller, the RS Series rotary actuator can provide simultaneous motion.
- The RS Series rotary actuator can be installed easily using the standard T-slots on our AS Series actuators.
(Some models require the use of installation brackets.)
- Arms or other end-effectors are easily attached. Some application examples are shown to the right.
- A "Key-Slot" option is also available. (Except for the RS-35, economy type)

Application Examples

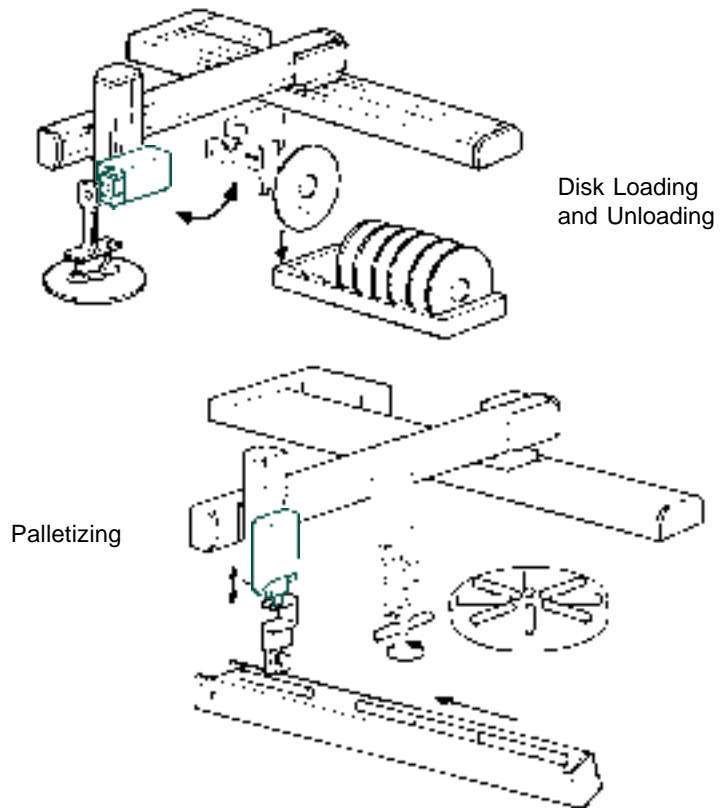

Model

12RS - 30 - 360 - 50 - AC - K

1 2 3 4 5 ⊕

1 Type

2 Motor Output

20 : 20W
30 : 30W
35 : 35W (Economy Type)
50 : 50W
60 : 60W

3 Movement Range

360 : 360 degree

4 Speed Reduction Ratio

10 : 1/10 (Kobatec)
50 : 1/50 (Harmonic)
100 : 1/100 (Harmonic)

5 Motor Type

DC (or no indicator): DC motor
AC: AC motor
ISAC: AC motor for IS actuator

⊕ Options

K : Key-Slot Option (Output Shaft)



Mounting example

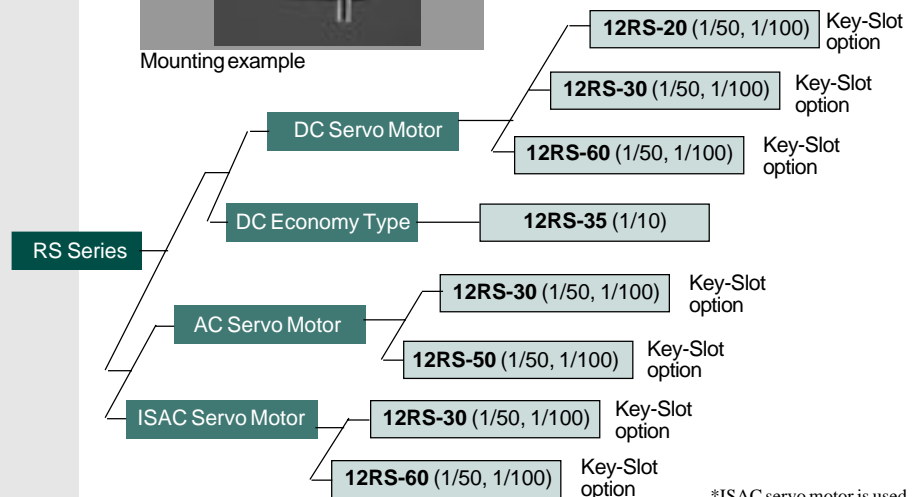

*ISAC servo motor is used with the IS Series actuators

DC Type

Specifications and Dimensions

Model		12RS-20-DC	12RS-30-DC	12RS-60-DC	12RS-35-DC	
Speed Reduction		Harmonic drive • 1/50, 1/100			Kobatec • 1/10	
Movement Range	degree	0 ~ 360°				
Rated Output	W	20	30	60	35	
Rated Speed	degree/sec	1/50	300	360	1800	
		1/100	150	180		
Rated Torque	N-m(Kgf-cm)	1/50	2.1(21)	3.3(34)	6.7(68)	0.87(8.91)
		1/100	4.1(42)	6.3(64)	13.3(136)	
Repeatability	degree	±0.028			±0.15	
Weight	kg	1.1	2.2	3.7	1.2	
Maximum Speed	degree/sec	1/50	450		2400	
		1/100	225			
Maximum Torque	N-m(Kgf-cm)	1/50	4.9(50)	6.3(64)	13.3(136)	1.98(20.25)
		1/100	7.8(80)	12.5(128)	26.7(272)	
Load Moment	N-m(Kgf-cm)	4.9(50) or less	98(100) or less	24.5(250) or less	9.8(10) or less	
Load Inertia	kg · m ² (Kgf-cm-s ²)	1/50	0.0306(0.3125) or less	0.0578(0.59) or less	0.196(2) or less	0.00469 or less
		1/100	0.1225(1.25) or less	0.2303(2.35) or less	0.784(8) or less	(0.04789) or less

12RS-20-DC

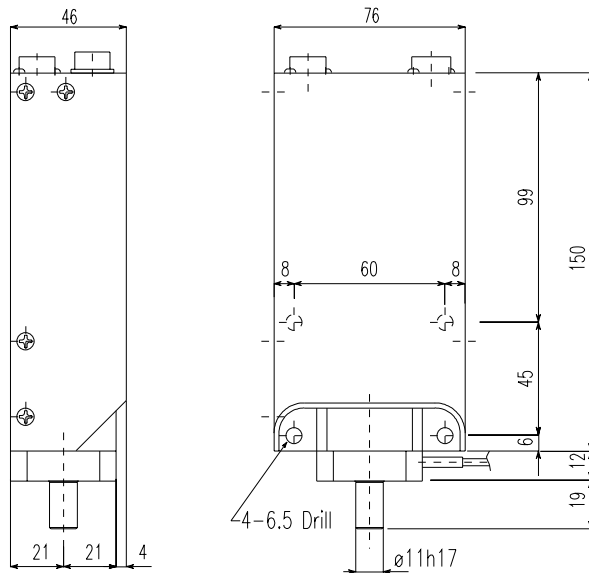

Key-Slot Shaft Measurements

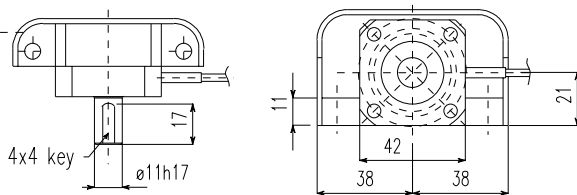

12RS-30-DC

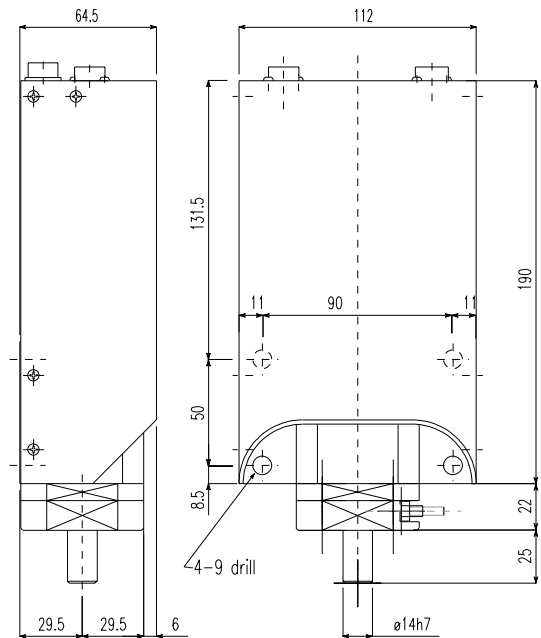

Key-Slot Shaft Measurements

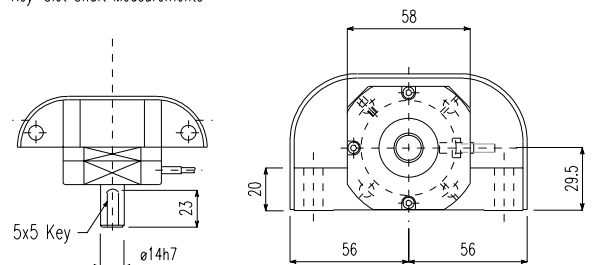

DC Type

Dimensions

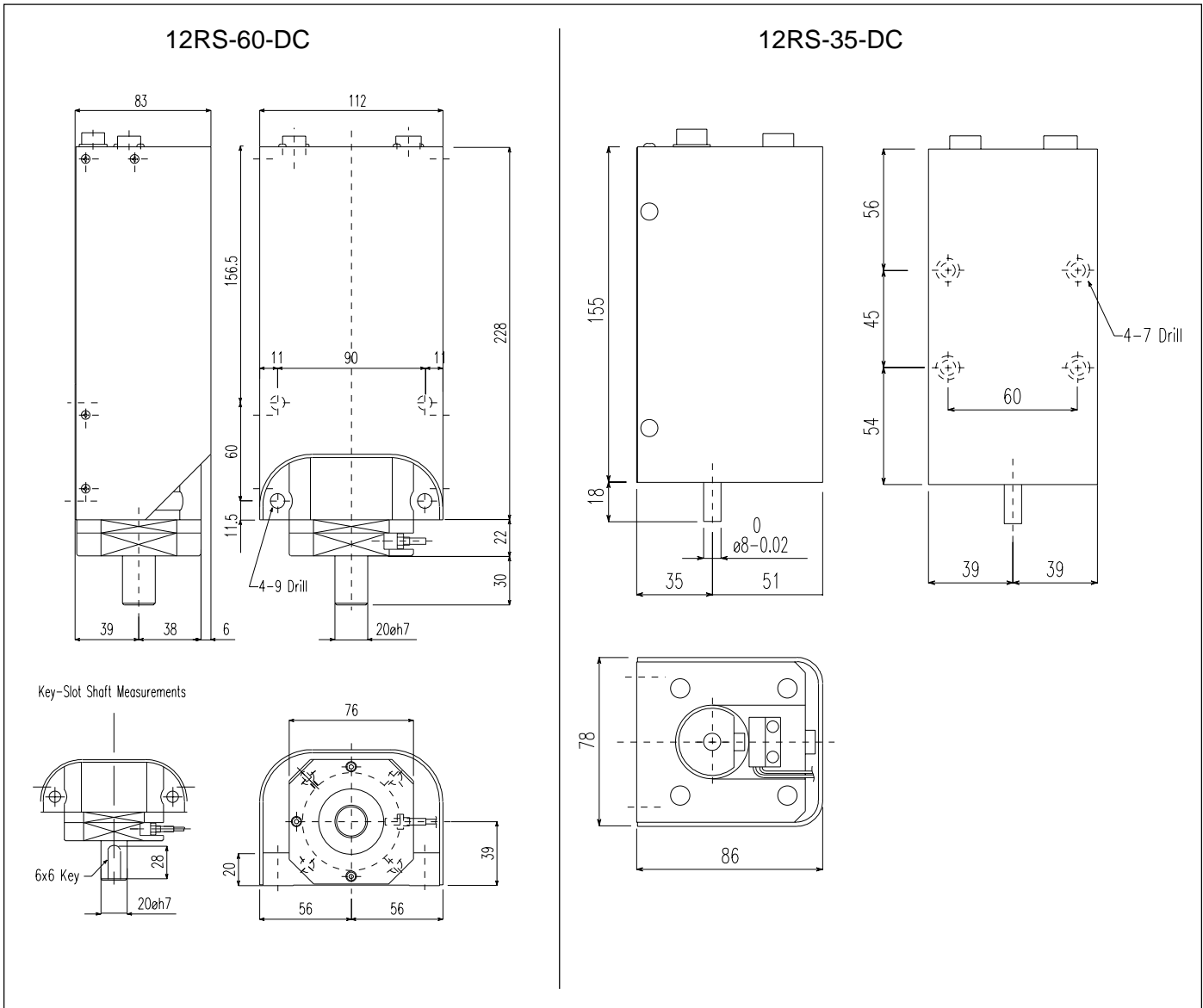

Installation of Arm or Other End-Effectors

To install an arm or other end-effectors onto your RS Series rotary actuator, use a split clamping method or a shaft-hub locking device as shown below:

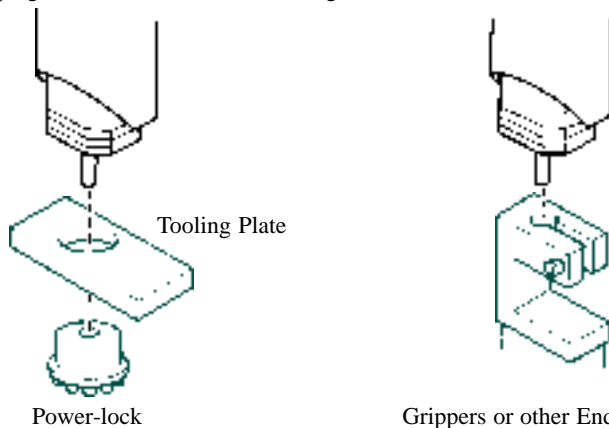

Rotary Actuator
RS SERIES

AC Type

Specifications and Dimensions

Model		12RS-30-AC[ISAC]	12RS-50[60]-AC[ISAC]
Speed Reduction		Harmonic drive • 1/50, 1/100	
Movement Range	degree	0 ~ 360°	
Rated Output	W	30	50
Rated Speed	degree/sec	1/50	360
		1/100	180
Rated Torque	N-m(Kgf-cm)	1/50	3.3(34.1)
		1/100	6.65(68.2)
Repeatability	degree	±0.028	
Weight	kg	2.0	3.2
Maximum Speed	degree/sec	1/50	450
		1/100	225
Maximum Torque	N-m(Kgf-cm)	1/50	6.6(68.2)
		1/100	13.3(136.4)
Load Moment	N-m(Kgf-cm)	9.8(100) or less	23.5(240) or less
Load Inertia	kg · m ² (Kgf-cm-s ²)	1/50	0.0578(0.59) or less
		1/100	0.2303(2.35) or less

12RS-30-AC[ISAC]

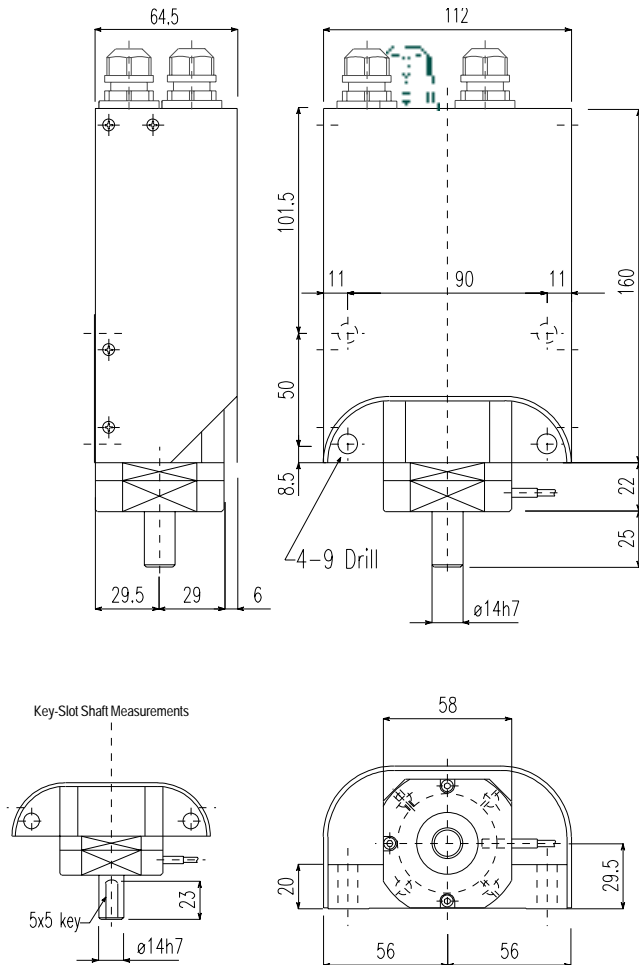

12RS-50[60]-AC[ISAC]

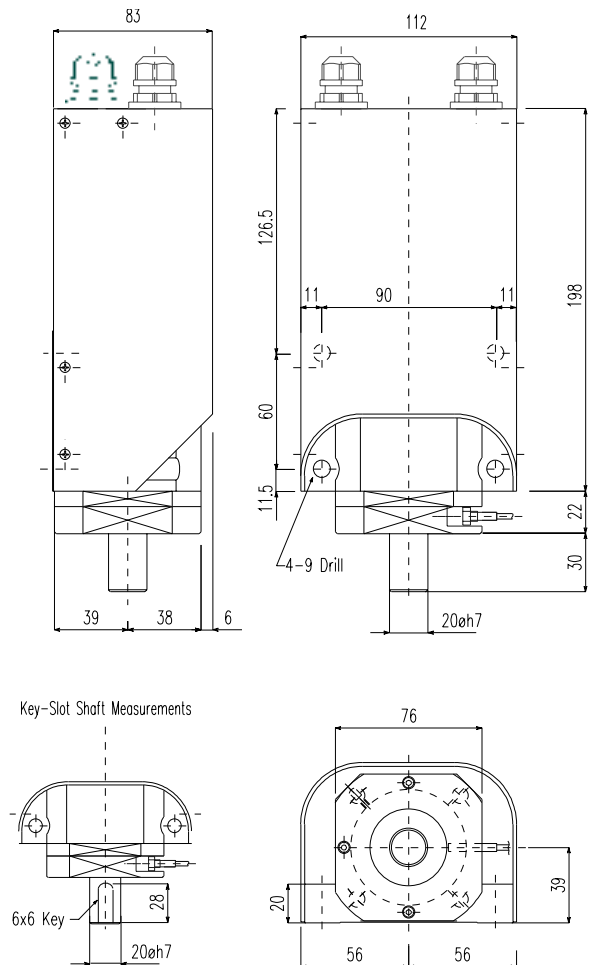

Selecting the Right RS Series Model for Your Particular Application

Speed and Load Inertia

First, determine the actuator speed required in your application. Second, determine the load inertia based on the shape and the weight of the arm, chuck, or other end-effector to be attached to the rotating axis of your RS Series rotary actuator. Third, refer to the table below and select an actuator model with a larger load inertia than that required in your system.

Model	12RS-20-DC		12RS-30-DC		12RS-60-DC		12RS-30-AC [ISAC]		12RS-50[60] AC[ISAC]		12RS-35-D-C
	1/50	1/100	1/50	1/100	1/50	1/100	1/50	1/100	1/50	1/100	1/10 (economy)
Speed Reduction Ratio	1/50	1/100	1/50	1/100	1/50	1/100	1/50	1/100	1/50	1/100	1/10 (economy)
Rated Speed (degree/s)	300	150	360	180	360	180	360	180	360	180	1800
Maximum Speed (degree/s)	540	225	450	225	450	225	450 [360]	225 [180]	450 [360]	225 [180]	2400
Load Inertia kg•m ² (kgf-cm-S ²)	0.031 (0.31)	0.123 (1.25)	0.058 (0.59)	0.23 (2.35)	0.2 (2)	0.78 (8)	0.058 (0.59)	0.23 (2.35)	0.11 (1.1)	0.42 (4.3)	0.0047 (0.048)

Load Capacity and Load Inertia of the Motor

Load inertia is determined by the weight and the shape of the body, and is expressed as $J = \int r^2 dm$. The load inertia of a simple shaped body is expressed as $J = MK^2$. With the RS series rotary actuators, rotating force is applied to the payload which causes it to spin around. This rotating force is expressed as torque. Torque is also called the moment of force.

In linear motion, when force is applied to a weight (inertia), acceleration is generated in the direction of the force.

$$F = M \cdot \alpha$$

F : Force N(kgf)
 M : Weight (kg)
 α : Acceleration (cm/s²)



In a rotational motion, when torque is applied to a body which has a load inertia, angular acceleration is generated. Therefore, the load capacity of a rotary actuator is expressed in terms of load inertia.

$$T = J \cdot \omega$$

T : Torque N-m(kgf-cm)
 J : Load Inertia kg-m² (kgf-cm-s²)
 ω : Angular Acceleration (rad/s²)

Determining the Load Inertia of a Typical Shaped Body

J : Load Inertia (kg-m²) W : Load Weight (kg) g : Gravity Speed (9.8m/s²)

① Cylinder (Thin Circular Plate)	② Thin Rectangle (Rectangular Parallelepiped)	③ Thin Rectangle Plate (Rectangular Parallelepiped)
Rotating axis is at the center of the axis.  $J = M \cdot \frac{r^2}{2}$	Rotating axis goes through the center of gravity of the plate, and is perpendicular to the axis.  $J = M \cdot \frac{a^2 + b^2}{12}$	Rotating axis goes through a point on the plate, which is perpendicular to the axis.  $J = M_1 \cdot \frac{4a_1^2 + b^2}{12}$ $M_2 \cdot \frac{4a_2^2 + b^2}{12}$

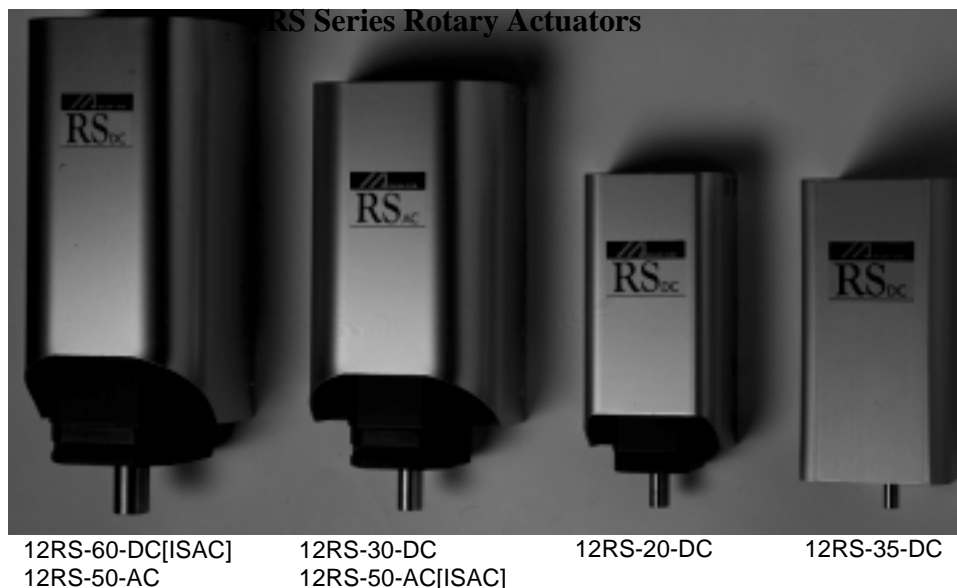

Guidelines for Rotary Actuator Model Selection

To select the right RS Series actuator for your application, consider the position of the payload to be attached to the output shaft of the actuator. Refer to the model selection guidelines below:

A. Payload is centered and located directly below the actuator.

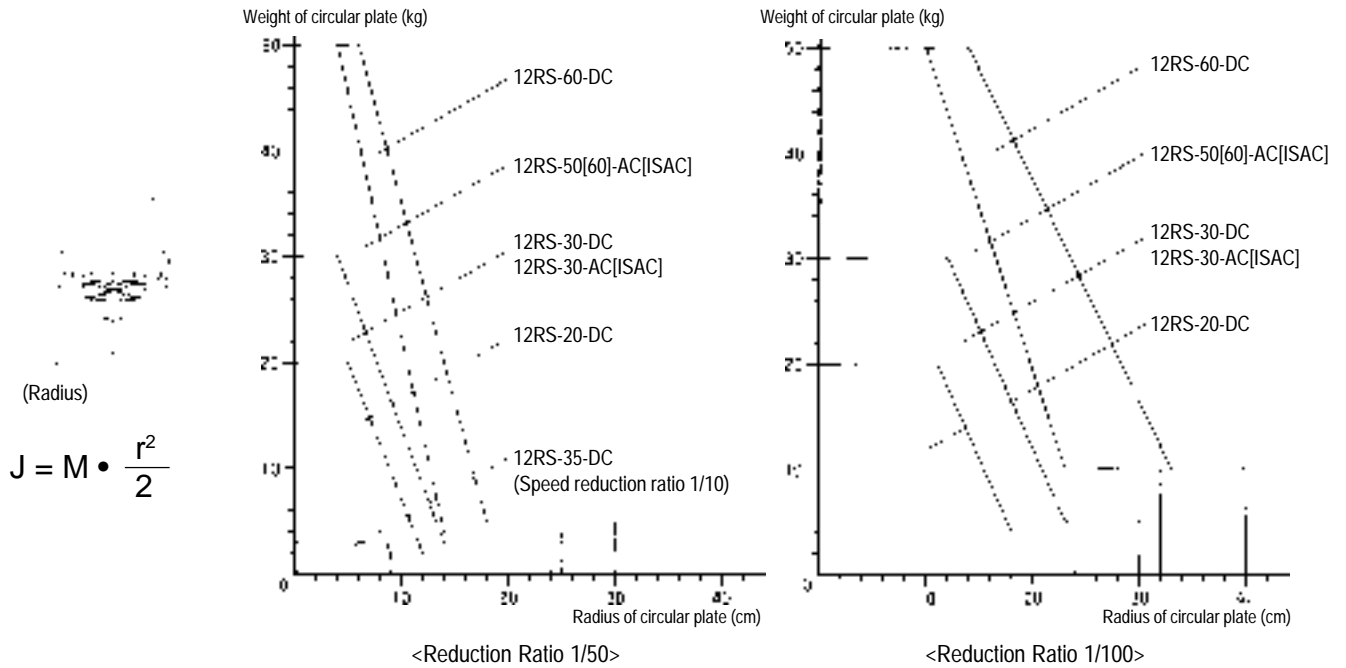

B. Payload is offset from the rotating axis shaft of the actuator.

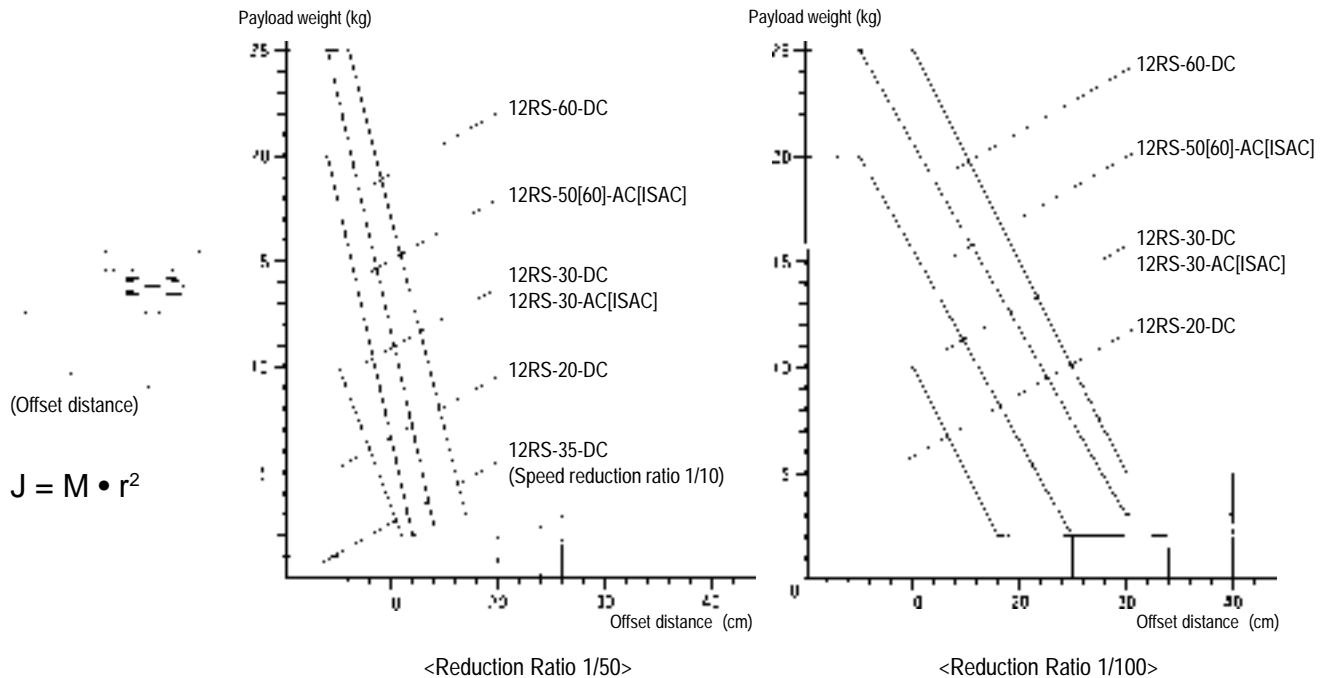

**RS Series (second edition)
Catalog No. 0998**

Providing Quality Products since 1986.

U.S. Sales Offices



IAI America, Inc. (U.S. Headquarters)
2690 West 237th Street, Torrance, CA 90505
(800) 736-1712 (310) 891-0815 FAX

IAI America, Inc. (Illinois Regional Office)
1261 Hamilton Parkway, Itasca, IL 60143
(800) 944-0333 (630) 467-9912 FAX

IAI America, Inc. (New Jersey Regional Office)
7 South Main Street Suite-F, Marlboro, NJ 07746
(732) 683-9101 (732) 683-9103 FAX

www.intelligentactuator.com