

PROMESS electro-mechanical assembly presses are particularly suitable for demanding joining, forming or testing tasks with integrated force-distance monitoring. A typical area of application is automated assembly processes that require high repeatability and monitoring of the joining quality, as well as documentation options.

DESIGN

The assembly press is based on a spindle with guidance, which is installed in a solid steel housing. The systems consist of robust mechanical components with AC servo motor, ball or roller gear drive spindle for converting rotational movement into linear movement, integrated force transducer for direct measurement of the joining forces, as well as the control.

KEY FEATURES

- Integrated force, position and signal control
- Real-time force-distance analysis directly in the servo amplifier
- No external analysis system required
- Safety brake for category 4 optional
- Envelope and window functions
- Robust, tried-and-tested servo drive technology, no special hollow shaft motor solution

ADDITIONAL FEATURES

- Absolute encoder eliminates the need for a reference run
- Positioning by means of external position transducers possible
- Only one measurement range required, thanks to high-precision force transducer
- Drift-free force measurement with high-precision strain gauge force transducer for push and pull forces
- All customary bus systems are supported
- Compensation against bending
- Service life of bearings and threaded drive >12 million cycles
- In-house production
- Most comprehensive range of assembly presses
- Modular design allows versatile equipment configurations



FUNCTIONAL PRINCIPLE

Actuation is performed by an AC servo motor. The rotational movement of the servo motor is transferred to the ball or roller gear drive and the press ram, where it is converted to linear movement. With the spindle drive, the assembly press is able to apply the full force both in push and pull directions. The sequence of movements can be easily specified using the included control and monitoring software. The envelope and window functions make full monitoring and documentation of the assembly process possible.



| MAIN FUNCTIONS | |
|--|-----------------------------------|
| Nominal load | +/- 40 kN |
| Stroke | 330 mm |
| Nominal speed | 240 mm/s |
| Acceleration | 1000 mm/s ² |
| Dwell time of nominal load | at least 4 s |
| Weight | 161,6 kg |
| Max. tool weight | 20 kg * |
| FORCE MEASURING | |
| Characteristic value | 1 mV / V |
| Transducer accuracy (dismantled) | 0,5 % |
| System accuracy | < 1 % |
| Smallest measuring step | 10,74 N |
| Amplifier / W*H*D | Alu. die-cast hous. / 64*35*58 mm |
| Output signal | +/- 10 VDC |
| Protection class | IP 54 |
| DISTANCE MEASURING | |
| Resolution | 0,06 µm |
| Repeatability of positioning | < 0,01 mm ** |
| Drive / (W*H*D) | SP2401 / (155*389*260 mm) |
| Mains voltage | 3 AC 380 V - 480 V, +/-10% |
| Cable cross sectional – area | 4 / 2,5 mm ² |
| Protection class | IP 20 |
| Weight | 7 kg |
| Recommended protection | IEC gG / 20 A |
| Temperature range | - 10 ... + 50 °C |
| Thermal power loss | 266 W |
| ADDITIONAL INPUTS | |
| 1x Analog / 1x Incremental | 11 Bit / Encoder (max. 410 kHz) |
| INTERFACE PC | |
| Ethernet / RS 485 | |
| PLC INTERFACE (24 VDC) | |
| Standard (Option) | 3I / 4O (16I / 16O) |
| OPTION: PLC FIELDBUS INTERFACE | |
| Profibus, CANOpen, Interbus, DeviceNet | |

* if using a holding break = nominal load / ** at thermal steady-state

SCOPE OF SUPPLY AND SERVICE

A complete package consisting of press mechanics with drive chain, servo amplifier and the Windows-based operating software is included in the scope of supply of an assembly unit. The entire system is completely preconfigured and calibrated by PROMESS and ready for operation.

The system can be optionally modified using cable sets, field busses, press frames, mounting plates or electric cabinets.

PROMESS offers first-rate support with spare parts and service from a single source. This includes pilot testing, process analysis, start-up support and maintenance contracts.

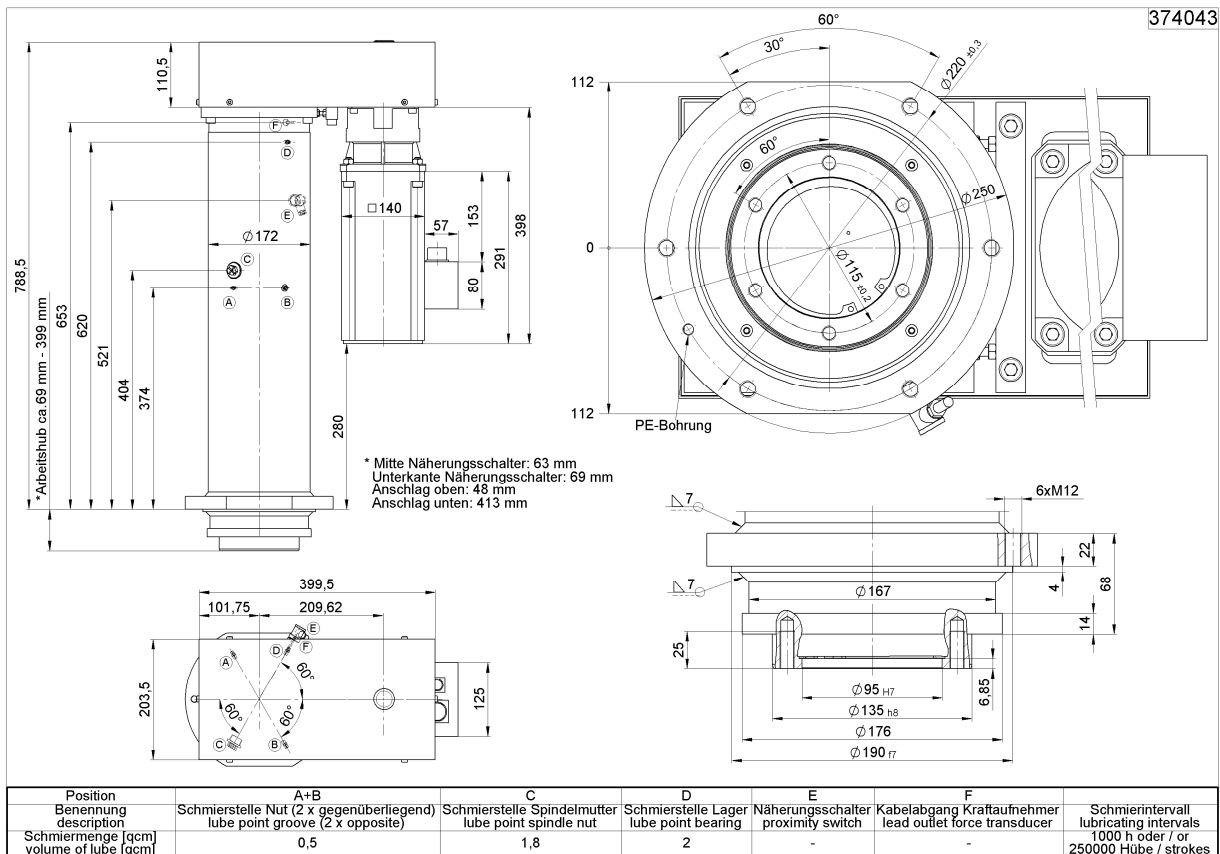

PROMESS Gesellschaft für Montage- und Prüfsysteme mbH
 Nunsdorfer Ring 29 | D-12277 Berlin
 Telefon +49 (0)30 / 62 88 72-0
 Fax +49 (0)30 / 62 88 72-59
 promess@promessmontage.de
 www.promessmontage.de

Geschäftsführung
 Dr.-Ing. Gerhard Lechler
 Dipl.-Ing. oec. Florian Köhnen
 Amtsgericht Charlottenburg
 HRB 68 818

BLZ 100 700 24 | Deutsche Bank
 Kto.-Nr. 162 674 600
 IBAN DE41 1007 0024 0162 674 600
 BIC DEUTDE33
 Ust-Ident-Nr. DE 812 448237

All specifications in the data sheets are valid at the print date. Before basing your own calculations/usage on the listed information, please inform yourself whether the information at your disposal is up-to-date. We do not accept any liability for correctness of the information.. Status: Sept. 2009