

Simple Dust-proof Type

ISDA/ISPDA

Cleanroom Type

ISDACR/ISPDACR

Significantly improved maintainability and acceleration
Cleanroom specification with a maximum stroke of 2500 mm

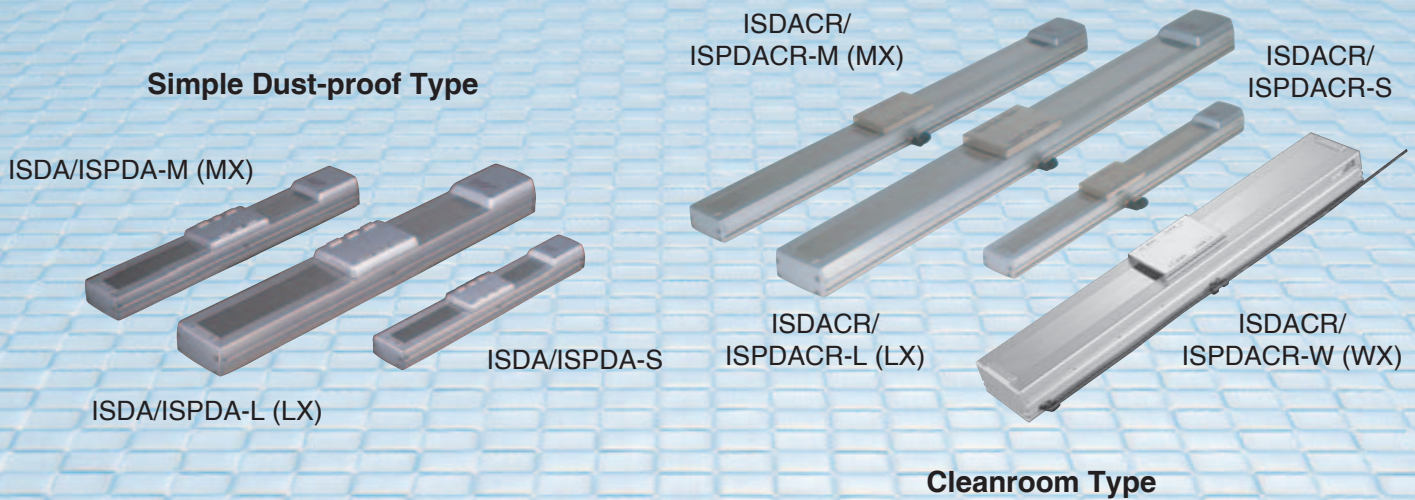

Features

1. Increased maximum acceleration of 1G (9800 mm/sec²)

As with the ISA Series, you can now set a maximum acceleration/deceleration of up to 1 G.

2. New simple dust-proof type (IP40) and cleanroom type (ISO class 4)

The new simple dust-proof type and cleanroom type both adopt protection structure made of stainless sheet.

3. Cleanroom type with a long maximum stroke of 2500 mm

The improvement of the mid-support mechanism and stainless sheet structure realized a long maximum stroke of 2500mm.

4. All models now adopt coupling specification

The motor/ball screw assembly was changed to coupling connection, without changing the overall length. This allows easy replacement in the event of motor failure.

Example of Use

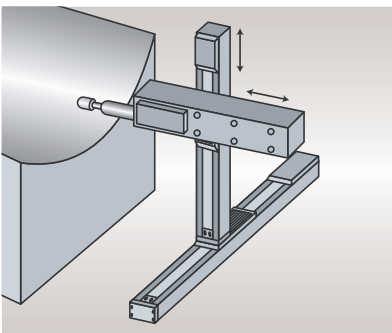

Simple dust-proof type (ISDA/ISPDA)
[For deburring applications]

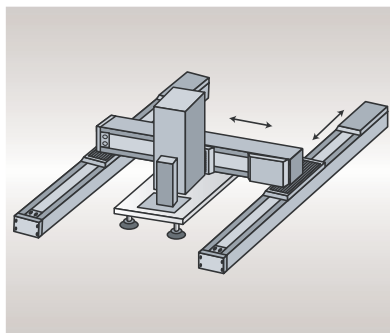

Cleanroom type (ISDACR/ISPDACR)
[For transferring glass substrates]

Model

● Specification Items for Simple Dust-proof Type and Cleanroom Type

ISDA - M - A - 200 - 20 - 500 - T1 - M - RT

<p>Series</p> <p>ISDA: Standard dust-proof specification</p> <p>ISPDA: High-precision dust-proof specification</p> <p>ISDACR: Standard cleanroom specification</p> <p>ISPDACR: High-precision cleanroom specification</p>	<p>Encoder type</p> <p>A: Absolute I: Incremental</p>	<p>Type</p> <p>S: Actuator width 94mm M: Actuator width 125mm MX: Actuator width 125mm Mid-support type L: Actuator width 155mm LX: Actuator width 155mm Mid-support type W: Actuator width 198mm WX: Actuator width 198mm Mid-support type</p>	<p>Motor</p> <p>60: 60W 100: 100W 200: 200W 400: 400W 600: 600W 750: 750W</p>	<p>Lead (mm)</p> <p>4: 4mm 5: 5mm 8: 8mm 10: 10mm 16: 16mm 20: 20mm 25: 25mm 40: 40mm 50: 50mm</p> <p>* The selectable leads vary depending on the model.</p>	<p>Stroke (mm)</p> <p>100 ~ 2500</p> <p>* The stroke range varies depending on the model.</p>	<p>Applicable controller</p> <p>T1: XSEL-KE/KT E - Con T2: XSEL-P/Q SSEL S - Con</p>	<p>Cable length</p> <p>N: No cable S: 3m M: 5m X□□: Specified length</p> <p>* The standard cable is a robot cable.</p>	<p>Options</p> <p>AQ: AQ seal B: Brake C: Creep sensor L: Home limit switch LM: Master-axis designation for synchronized operation NM: Reversed home S: Slave-axis designation for synchronized operation RT: Guide with ball-retaining mechanism VR: Suction duct joint on opposite side ESD: Anti-electrostatic specification EU: Metal cable joint connector (see page 2 and back)</p>
--	--	--	--	--	--	---	---	--

Specification Table

Type	Stroke (mm) and maximum speed (mm/sec) (Note 1)															Load capacity (Note 2)		Motor capacity (w)	Lead (mm)	Model
	100 ~ 500	600	700	800	900	1000	1100	1200	1300	1400	1500	1600	1700 ~ 2000	2100 ~ 2500	(kg)	(kg)				
Simple dust-proof type	800	760														12		60	16	IS (P) DA-S-□-60-16-□□□
	400	380														25		60	8	IS (P) DA-S-□-60-8-□□□
	200	190														50		60	4	IS (P) DA-S-□-60-4-□□□
	1000	915	735	600	500											20		100	20	IS (P) DA-M-□-100-20-□□□
	500	455	365	300	250											40		100	10	IS (P) DA-M-□-100-10-□□□
	250	225	180	150	125											80		100	5	IS (P) DA-M-□-100-5-□□□
	1000	915	735	600	500											40		200	20	IS (P) DA-M-□-200-20-□□□
	500	455	365	300	250											80		200	10	IS (P) DA-M-□-200-10-□□□
						1000				950	800	700				40		200	20	IS (P) DA-MX-□-200-20-□□□
		1000	930	765	640	545	465									40	9	200	20	IS (P) DA-L-□-200-20-□□□
		500	465	380	320	270	230									80	19	200	10	IS (P) DA-L-□-200-10-□□□
	Cleanroom type	800	760														12	3	60	16
400		380														25	6	60	8	IS (P) DACR-S-□-60-8-□□□
200		190														50	14	60	4	IS (P) DACR-S-□-60-4-□□□
1000		915	735	600	500											20	3.5	100	20	IS (P) DACR-M-□-100-20-□□□
500		455	365	300	250											40	9	100	10	IS (P) DACR-M-□-100-10-□□□
250		225	180	150	125											80	19	100	5	IS (P) DACR-M-□-100-5-□□□
1000		915	735	600	500											40	9	200	20	IS (P) DACR-M-□-200-20-□□□
500		455	365	300	250											80	19	200	10	IS (P) DACR-M-□-200-10-□□□
						1000				950	800	700	600 ~ 450			40	-	200	20	IS (P) DACR-MX-□-200-20-□□□
		1000	930	765	640	545	465									40	9	200	20	IS (P) DACR-L-□-200-20-□□□
		500	465	380	320	270	230									80	19	200	10	IS (P) DACR-L-□-200-10-□□□
		1000	930	765	640	545	465									80	19	400	20	IS (P) DACR-L-□-400-20-□□□
										1000	950	830	740 ~ 540	490 ~ 340		40	-	200	20	IS (P) DACR-LX-□-200-20-□□□
										1000	950	830	740 ~ 540	490 ~ 340		80	-	400	20	IS (P) DACR-LX-□-400-20-□□□
		2000	1965	1605	1335	1130	970	840								60	14	600	40	IS(P)DACR-W-□-600-40-□□□
		1000	980	800	685	565	485	420								120	29	600	20	IS(P)DACR-W-□-600-20-□□□
		500	490	400	330	280	240	210								150	60	600	10	IS(P)DACR-W-□-600-10-□□□
		2000				1780	1525	1320								60	14	750	50	IS(P)DACR-W-□-750-50-□□□
	1250				1050	890	760	660							120	29	750	25	IS(P)DACR-W-□-750-25-□□□	
					2000	1965	1725	1530	1385 ~ 1005	915 ~ 655					60	-	600	40	IS(P)DACR-WX-□-600-40-□□□	
					1000	980	860	765	680 ~ 500	455 ~ 325					120	-	600	20	IS(P)DACR-WX-□-600-20-□□□	
					2000				2000 ~ 1580	1440 ~ 1035					60	-	750	50	IS(P)DACR-WX-□-750-50-□□□	
					1250				1200	1075 ~ 790	720 ~ 515				120	-	750	25	IS(P)DACR-WX-□-750-25-□□□	

ISDA-S Single-Axis Robot: Compact Dust-proof Type, Actuator Width 94mm, 60W Straight Shape

ISPDA-S Single-Axis Robot: Compact Dust-proof Type, Actuator Width 94mm, 60W Straight Shape, High-Precision Specification

Type/Compact dust-proof (94 mm wide) Stroke/100~600mm Load capacity/50kg (horizontal)/14kg (vertical)

Model specification items Series Type Encoder type Motor output Lead Stroke Applicable controller Cable length Options

(Example) ISDA - S - A - 60 - 16 - 600 - T1 - S - B

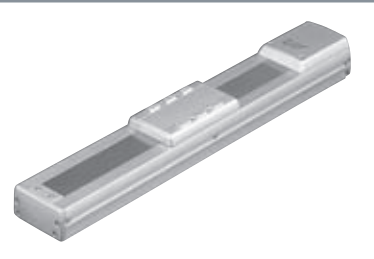

* Refer to page 1 for the details of model specification items.

Model/Specifications

Model	Encoder Type	Motor output (W)	Lead (mm)	Stroke 50mm increments (mm)	Speed (mm/s) (Note 1)	Load capacity (Note2)				Rated thrust (N)	Positioning repeatability (mm) (Note 3)
						Horizontal (kg)		Vertical (kg)			
						Rated acceleration	Maximum acceleration	Rated acceleration	Maximum acceleration		
ISDA [ISPDA]-S- [1]-60-16- [2]- [3]- [4]- [5]	Absolute Incremental	60	16	100 ~ 600	1 ~ 800	12	3.5	3	2	63.7	0.02 [0.01]
ISDA [ISPDA]-S- [1]-60-8- [2]- [3]- [4]- [5]			8		1 ~ 400	25	12	6	5	127.4	
ISDA [ISPDA]-S- [1]-60-4- [2]- [3]- [4]- [5]			4		1 ~ 200	50	30	14	12	254.8	

* In the above model names, [1] indicates the encoder type, [2] the stroke, [3] the applicable controller, [4] the cable length, and [5] the applicable options.

Options

Name	Code	Page	Remarks
AQ seal	AQ	→P22	
Brake	B	→P22	
Reversed home specification	NM	→P22	
Guide with ball-retaining mechanism	RT	→P22	
Metal cable joint connector	EU	→Back	

Common Specifications

Drive system (Note 4)	Ball screw ϕ 12mm, rolled C10 [equivalent to rolled C5]
Backlash (Note 5)	0.05mm or less [0.02mm or less]
Guide	Integrated with base
Allowable load moment	Ma: 28.4Nm, Mb: 40.2Nm, Mc: 65.7Nm
Overhang load length	Ma/Mb/Mc directions: 450mm or less
Base	Material: Special aluminum with white alumite treatment
Applicable controller	T1: XSEL-KE/KT, E-Con; T2: XSEL-P/Q, SSEL, S-Con
Cable length (Note 6)	S: 3m, M: 5m, X□□: Length specification
Ambient operating temperature/humidity	0~40°C, 85%RH (non-condensing)

Dimensions

* Note that changing the home direction will require the actuator to be returned to IAI for adjustment.

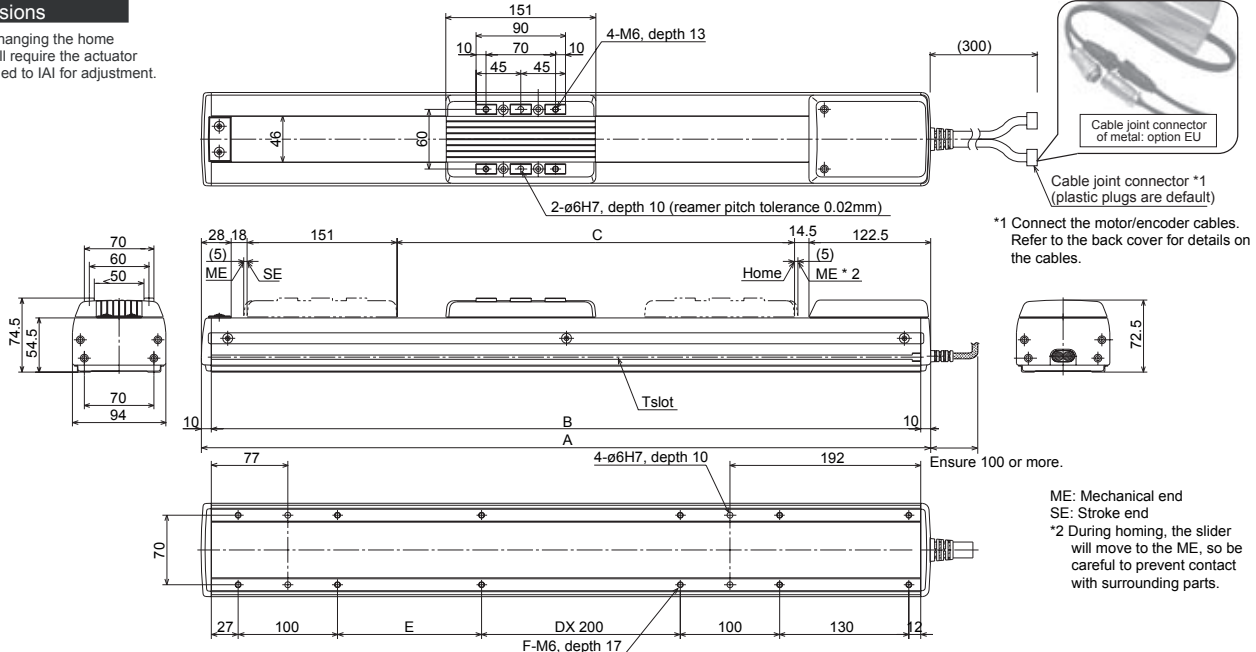

*1 Connect the motor/encoder cables. Refer to the back cover for details on the cables.

ME: Mechanical end
SE: Stroke end
*2 During homing, the slider will move to the ME, so be careful to prevent contact with surrounding parts.

Brake type (optional)

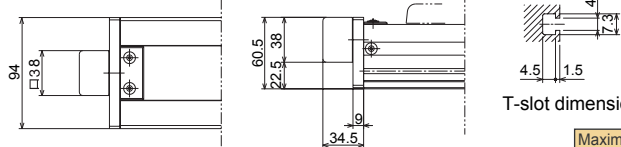

* Actuators with the brake are longer by 24.5 mm and heavier by 0.3 kg than their non-brake counterparts.

Stroke	100	150	200	250	300	350	400	450	500	550	600
A	434	484	534	584	634	684	734	784	834	884	934
B	414	464	514	564	614	664	714	764	814	864	914
C	100	150	200	250	300	350	400	450	500	550	600
D	-	-	-	-	1	1	1	1	2	2	2
E	45	95	145	195	45	95	145	195	45	95	145
F	10	10	10	10	12	12	12	12	14	14	14
Weight (kg)	3.8	4.1	4.4	4.7	5.1	5.4	5.7	6.0	6.3	6.6	7.0

Maximum speed (mm/s) * Varies depending on the stroke.	Lead 16	800	760
	Lead 8	400	380
	Lead 4	200	190

Applicable Controller Specifications

Applicable controller	Maximum number of controlled axes	Compatible encoder type	Operating method	Supply voltage	Maximum Output
X-SEL-P/Q	6 axes	Absolute /incremental	Program/ Positioner	1-phase 230VAC/ 3-phase 200VAC	1600W/ 2400W
X-SEL-KE/KT	4 axes			1-phase 100VAC/ 230VAC	1600W
S-SEL	2 axes				800W
S-/E-Con	1 axis				750W

Caution

(Note 1) When the stroke increases, the maximum speed drops in order to prevent the ball screw from reaching a dangerous speed. (Refer to the above table for the maximum speed at each stroke.)

(Note 2) Refer to page 22 for the relationship of acceleration and load capacity.

(Notes 3, 4, 5) The figures in [] apply to the ISPDA Series.

(Note 6) The maximum cable length is 30 m. Specify a desired length in meters. (Example: X08 = 8 m)

ISDA-M-100

Single-Axis Robot: Medium Dust-proof Type, Actuator Width 125mm, 100W, Straight Shape

ISPDA-M-100

Single-Axis Robot: Medium Dust-proof Type, Actuator Width 125mm, 100W, Straight Shape, High-Precision Specification

Type / Medium dust-proof (125 mm wide) Stroke / 100~1000mm Load capacity / 80kg (horizontal)/19kg (vertical)

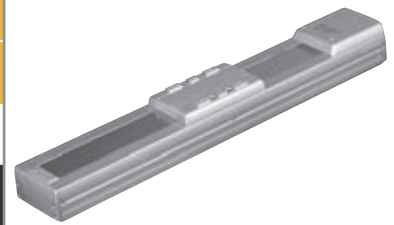

Model specification items Series Type Encoder type Motor output Lead Stroke Applicable controller Cable length Options

(Example) ISDA - M - A - 100 - 20 - 1000 - T1 - S - B

* Refer to page 1 for the details of model specification items.

Model/Specifications

Model	Encoder Type	Motor output (W)	Lead (mm)	Stroke 50mm increments (mm)	Speed (mm/s) (Note 1)	Load capacity (Note 2)				Rated thrust (N)	Positioning repeatability (mm) (Note 3)
						Horizontal (kg)		Vertical (kg)			
						Rated acceleration	Maximum acceleration	Rated acceleration	Maximum acceleration		
ISDA [ISPDA]-M-[1]-100-20-[2]-[3]-[4]-[5]	Absolute	100	20	100 ~ 1000	1 ~ 1000	20	6	3.5	2	84.3	0.02 [0.01]
ISDA [ISPDA]-M-[1]-100-10-[2]-[3]-[4]-[5]	Incremental		10		1 ~ 500	40	20	9	7	169.5	
ISDA [ISPDA]-M-[1]-100-5-[2]-[3]-[4]-[5]			5		1 ~ 250	80	45	19	15	340.1	

* In the above model names, [1] indicates the encoder type, [2] the stroke, [3] the applicable controller, [4] the cable length, and [5] the applicable options.

Options

Name	Code	Page	Remarks
AQ seal	AQ	→P22	
Brake	B	→P22	
Reversed home specification	NM	→P22	
Guide with ball-retaining mechanism	RT	→P22	
Metal cable joint connector	EU	→Back,P2	

Common Specifications

Drive system (Note 4)	Ball screw ϕ 16mm, rolled C10 [equivalent to rolled C5]
Backlash (Note 5)	0.05mm or less [0.02mm or less]
Guide	Integrated with base
Allowable load moment	Ma: 69.6Nm, Mb: 99.0Nm, Mc: 161.7Nm
Overhang load length	Ma/Mb/Mc directions: 600mm or less
Base	Material: Aluminum with white alumite treatment
Applicable controller	T1: XSEL-KE/KT, E-Con; T2: XSEL-P/Q, SSEL, S-Con
Cable length (Note 6)	S: 3m, M: 5m, X□□: Length specification
Ambient operating temperature/humidity	0~40°C, 85%RH (non-condensing)

Dimensions

* Note that changing the home direction will require the actuator to be returned to IAI for adjustment.

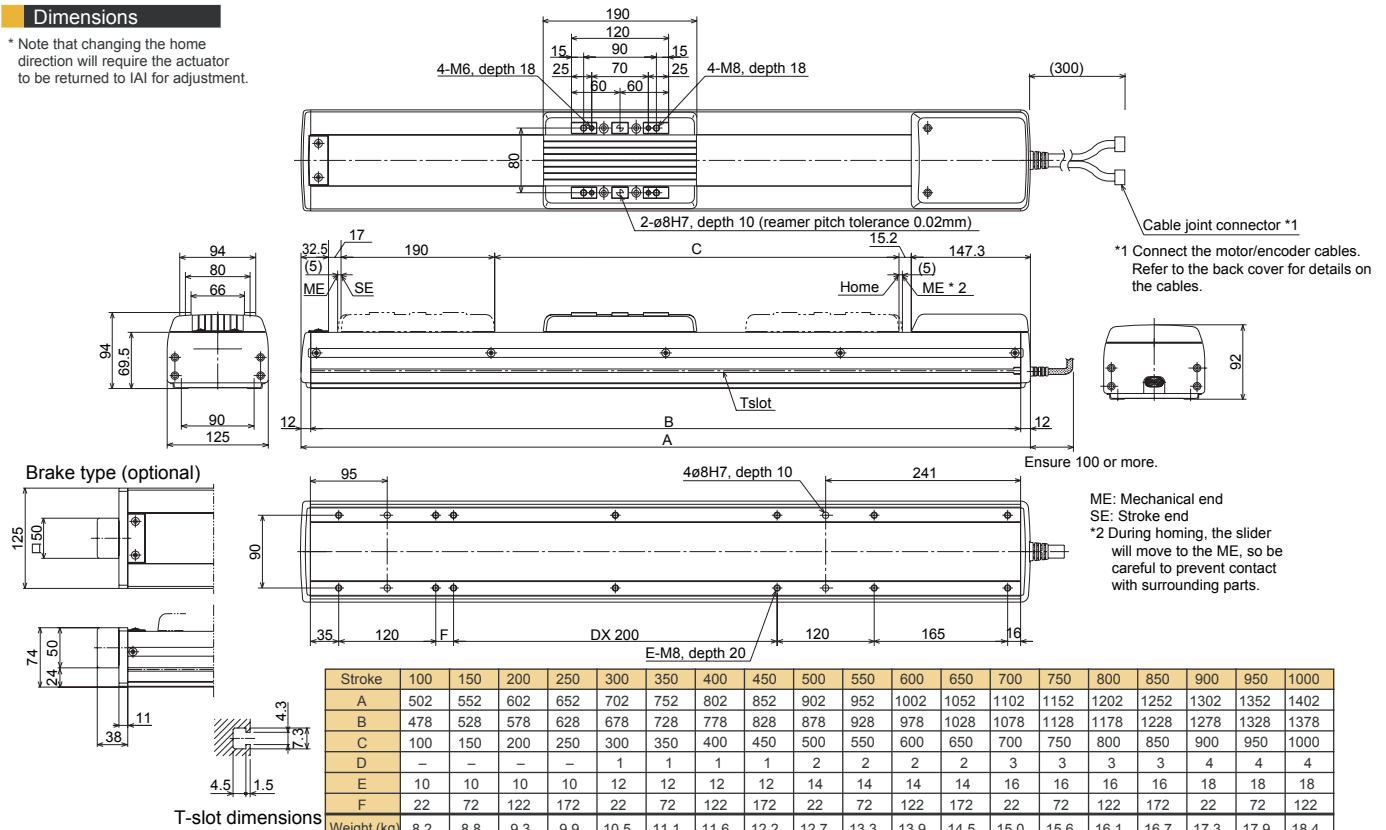

Stroke	100	150	200	250	300	350	400	450	500	550	600	650	700	750	800	850	900	950	1000
A	502	552	602	652	702	752	802	852	902	952	1002	1052	1102	1152	1202	1252	1302	1352	1402
B	478	528	578	628	678	728	778	828	878	928	978	1028	1078	1128	1178	1228	1278	1328	1378
C	100	150	200	250	300	350	400	450	500	550	600	650	700	750	800	850	900	950	1000
D	-	-	-	-	1	1	1	1	2	2	2	2	3	3	3	3	4	4	4
E	10	10	10	10	12	12	12	12	14	14	14	14	16	16	16	16	18	18	18
F	22	72	122	172	22	72	122	172	22	72	122	172	22	72	122	172	22	72	122
Weight (kg)	8.2	8.8	9.3	9.9	10.5	11.1	11.6	12.2	12.7	13.3	13.9	14.5	15.0	15.6	16.1	16.7	17.3	17.9	18.4
Maximum speed (mm/s)	Lead 20														1000	915	735	600	500
	Lead 10														500	455	365	300	250
	Lead 5														250	225	180	150	125

* Actuators with the brake are longer by 26 mm and heavier by 0.6 kg than their non-brake counterparts.

* Varies depending on the stroke.

Applicable Controller Specifications

Applicable controller	Maximum number of controlled axes	Compatible encoder type	Operating method	Supply voltage	Maximum Output
X-SEL-P/Q	6 axes	Absolute /incremental	Program/ Positioner	1-phase 230VAC/ 3-phase 200VAC	1600W/ 2400W
X-SEL-KE/KT	4 axes			1600W	
S-SEL	2 axes			800W	
S-E-Con	1 axis			750W	



(Note 1) When the stroke increases, the maximum speed drops in order to prevent the ball screw from reaching a dangerous speed. (Refer to the above table for the maximum speed at each stroke.)

(Note 2) Refer to page 22 for the relationship of acceleration and load capacity.

(Notes 3, 4, 5) The figures in [] apply to the ISPDA Series.

(Note 6) The maximum cable length is 30 m. Specify a desired length in meters. (Example: X08 = 8 m)

ISDA-M-200

Single-Axis Robot: Medium Dust-proof Type,
Actuator Width 125mm, 200W, Straight Shape

ISPDA-M-200

Single-Axis Robot: Medium Dust-proof Type,
Actuator Width 125mm, 200W, Straight Shape, High-Precision Specification

Type / Medium dust-proof (125 mm wide) Stroke / 100~1000mm Load capacity / 80kg (horizontal)/19kg (vertical)

Model specification items Series Type Encoder type Motor output Lead Stroke Applicable controller Cable length Options

(Example) ISDA - M - A - 200 - 20 - 1000 - T1 - S - B

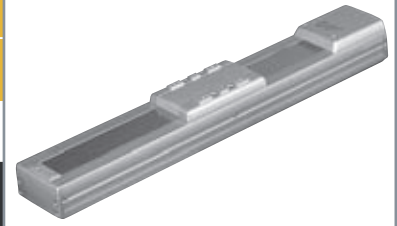

* Refer to page 1 for the details of model specification items.

Model/Specifications

Model	Encoder Type	Motor output (W)	Lead (mm)	Stroke 50mm increments (mm)	Speed (mm/s) (Note 1)	Load capacity (Note2)				Rated thrust (N)	Positioning repeatability (mm) (Note 3)
						Horizontal (kg)		Vertical (kg)			
						Rated acceleration	Maximum acceleration	Rated acceleration	Maximum acceleration		
ISDA [ISPDA]-M- [1]-200-20- [2]- [3]- [4]- [5]	Absolute	200	20	100 ~ 1000	1 ~ 1000	40	12	9	5	169.5	0.02 [0.01]
ISDA [ISPDA]-M- [1]-200-10- [2]- [3]- [4]- [5]	Incremental		10		1 ~ 500	80	40	19	15	340.1	

* In the above model names, [1] indicates the encoder type, [2] the stroke, [3] the applicable controller, [4] the cable length, and [5] the applicable options.

Options

Name	Code	Page	Remarks
AQ seal	AQ	→P22	
Brake	B	→P22	
Reversed home specification	NM	→P22	
Guide with ball-retaining mechanism	RT	→P22	
Metal cable joint connector	EU	→Back,P2	

Common Specifications

Drive system (Note 4)	Ball screw ϕ 16mm, rolled C10 [equivalent to rolled C5]
Backlash (Note 5)	0.05mm or less [0.02mm or less]
Guide	Integrated with base
Allowable load moment	Ma: 69.6Nm, Mb: 99.0Nm, Mc: 161.7Nm
Overhang load length	Ma/Mb/Mc directions: 600mm or less
Base	Material: Aluminum with white alumite treatment
Applicable controller	T1: XSEL-KE/KT, E-Con; T2: XSEL-P/Q, SSEL, S-Con
Cable length (Note 6)	S: 3m, M: 5m, X□□: Length specification
Ambient operating temperature/humidity	0~40°C, 85%RH (non-condensing)

Dimensions

* Note that changing the home direction will require the actuator to be returned to IA1 for adjustment.

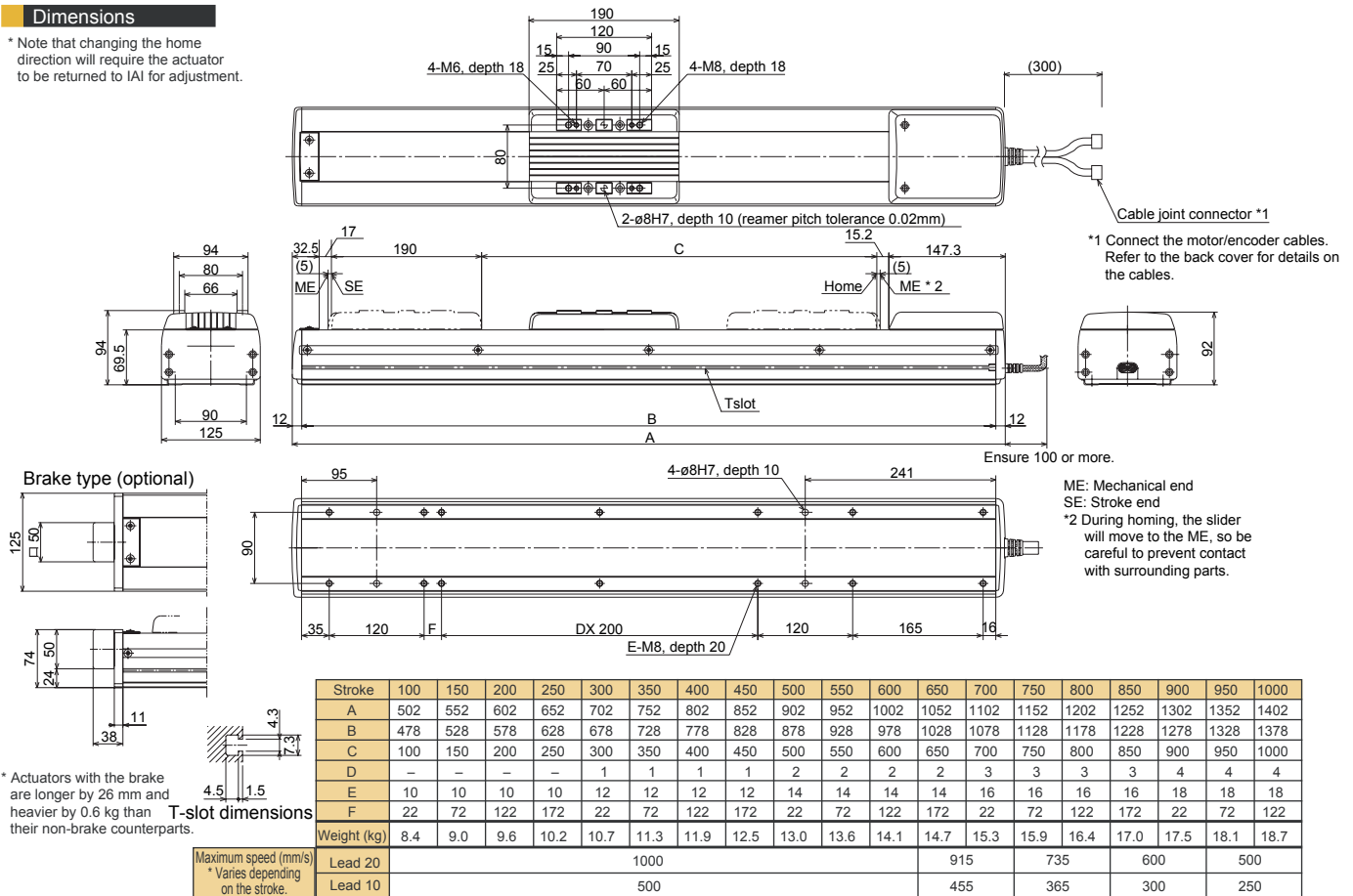

Applicable Controller Specifications

Applicable controller	Maximum number of controlled axes	Compatible encoder type	Operating method	Supply voltage	Maximum Output
X-SEL-P/Q	6 axes	Absolute /incremental	Program/ Positioner	1-phase 230VAC/ 3-phase 200VAC	1600W/ 2400W
X-SEL-KE/KT	4 axes			1600W	
S-SEL	2 axes			800W	
S-/E-Con	1 axis			750W	



(Note 1) When the stroke increases, the maximum speed drops in order to prevent the ball screw from reaching a dangerous speed. (Refer to the above table for the maximum speed at each stroke.)
(Note 2) Refer to page 22 for the relationship of acceleration and load capacity.
(Notes 3, 4, 5) The figures in [] apply to the ISPDA Series.
(Note 6) The maximum cable length is 30 m. Specify a desired length in meters. (Example: X08 = 8 m)

ISDA-MX-200 Single-Axis Robot: Medium Dust-proof Mid-support Type, Actuator Width 125mm, 200W, Straight Shape

ISPDA-MX-200 Single-Axis Robot: Medium Dust-proof Mid-support Type, Actuator Width 125mm, 200W, Straight Shape, High-Precision Specification

Type / Medium dust-proof (125 mm wide) Mid-support Type Stroke / 800~1600mm Load capacity / 40kg (horizontal)

Model specification items Series Type Encoder type Motor output Lead Stroke Applicable controller Cable length Options

(Example) ISDA - MX - A - 200 - 20 - 1600 - T1 - S - B

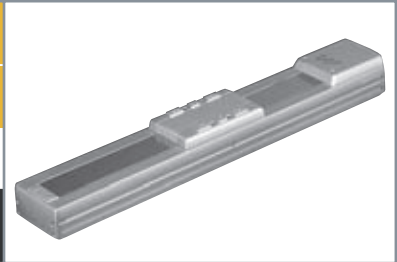

* Refer to page 1 for the details of model specification items.

Model/Specifications

Model	Encoder Type	Motor output (W)	Lead (mm)	Stroke 100mm increments (mm)	Speed (mm/s) (Note 1)	Load capacity (Note2)				Rated thrust (N)	Positioning repeatability (mm) (Note 3)
						Horizontal (kg)		Vertical (kg)			
						Rated acceleration	Maximum acceleration	Rated acceleration	Maximum acceleration		
ISDA [ISPDA]-MX-[1]-200-20-[2]-[3]-[4]	Absolute Incremental	200	20	800 ~ 1600	1 ~ 1000	40	Horizontal only		169.5	0.02 [0.01]	

* In the above model names, [1] indicates the encoder type, [2] the stroke, [3] the applicable controller, [4] the cable length, and [5] the applicable options.

Options

Name	Code	Page	Remarks
AQ seal	AQ	→P22	
Brake	B	→P22	
Reversed home specification	NM	→P22	
Guide with ball-retaining mechanism	RT	→P22	
Metal cable joint connector	EU	→Back,P2	

Common Specifications

Drive system (Note 4)	Ball screw ϕ 16mm, rolled C10 [equivalent to rolled C5]
Backlash (Note 5)	0.05mm or less [0.02mm or less]
Guide	Integrated with base
Allowable load moment	Ma: 69.6Nm, Mb: 99.0Nm, Mc: 161.7Nm
Overhang load length	Ma/Mb/Mc directions: 600mm or less
Base	Material: Aluminum with white alumite treatment
Applicable controller	T1: XSEL-KE/KT, E-Con; T2: XSEL-P/Q, SSEL, S-Con
Cable length (Note 6)	S: 3m, M: 5m, X□□: Length specification
Ambient operating temperature/humidity	0~40°C, 85%RH (non-condensing)

Dimensions

* Note that changing the home direction will require the actuator to be returned to IA1 for adjustment.

* Due to their structure, the mid-support type cannot be positioned horizontally on their side, or in vertical direction.

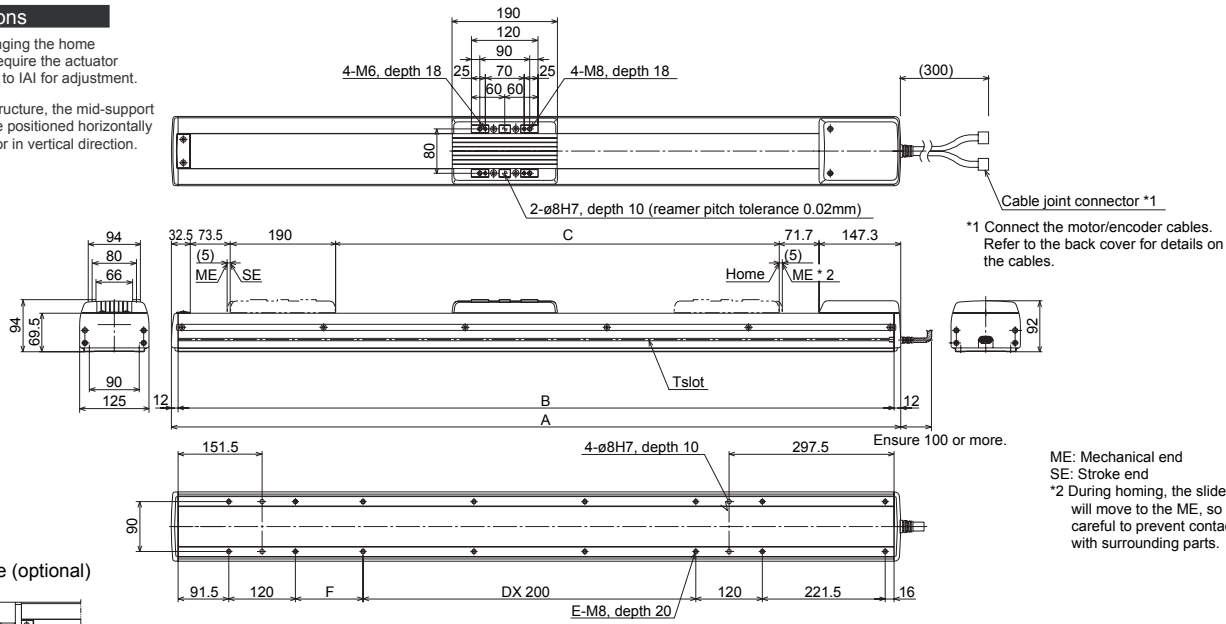

Brake type (optional)

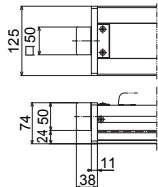

T-slot dimensions

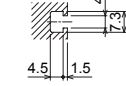

Stroke	800	900	1000	1100	1200	1300	1400	1500	1600	
A	1315	1415	1515	1615	1715	1815	1915	2015	2115	
B	1291	1391	1491	1591	1691	1791	1891	1991	2091	
C	800	900	1000	1100	1200	1300	1400	1500	1600	
D	3	3	4	4	5	5	6	6	7	
E	16	16	18	18	20	20	22	22	24	
F	122	222	122	222	122	222	122	222	122	
Weight (kg)	18.2	19.3	20.5	21.6	22.7	23.9	25.0	26.2	27.3	
Lead 20	1000						950	800	700	

* Actuators with the brake are longer by 26 mm and heavier by 0.6 kg than their non-brake counterparts.

Maximum speed (mm/s)
* Varies depending on the stroke.

Applicable Controller Specifications

Applicable controller	Maximum number of controlled axes	Compatible encoder type	Operating method	Supply voltage	Maximum Output
X-SEL-P/Q	6 axes	Absolute /incremental	Program/ Positioner	1-phase 230VAC/ 3-phase 200VAC	1600W/ 2400W
X-SEL-KE/KT	4 axes			1600W	
S-SEL	2 axes			800W	
S-/E-Con	1 axis			750W	



(Note 1) When the stroke increases, the maximum speed drops in order to prevent the ball screw from reaching a dangerous speed. (Refer to the above table for the maximum speed at each stroke.)
(Note 2) Refer to page 22 for the relationship of acceleration and load capacity.
(Notes 3, 4, 5) The figures in [] apply to the ISPDA Series.
(Note 6) The maximum cable length is 30 m. Specify a desired length in meters. (Example: X08 = 8 m)

ISDA-L-200

Single-Axis Robot: Large Dust-proof Type,
Actuator Width 155mm, 200W, Straight Shape

ISPDA-L-200

Single-Axis Robot: Large Dust-proof Type,
Actuator Width 155mm, 200W, Straight Shape, High-Precision Specification

Type / Large dust-proof (155 mm wide) Stroke / 100~1200mm Load capacity / 80kg (horizontal)/19kg (vertical)

Model specification items Series Type Encoder type Motor output Lead Stroke Applicable controller Cable length Options

(Example) ISDA - L - A - 200 - 20 - 1200 - T1 - S - B

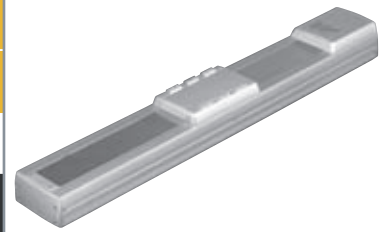

* Refer to page 1 for the details of model specification items.

Model/Specifications

Model	Encoder Type	Motor output (W)	Lead (mm)	Stroke 50mm increments (mm)	Speed (mm/s) (Note 1)	Load capacity (Note2)				Rated thrust (N)	Positioning repeatability (mm) (Note 3)
						Horizontal (kg)		Vertical (kg)			
						Rated acceleration	Maximum acceleration	Rated acceleration	Maximum acceleration		
ISDA [ISPDA]-L-[1]-200-20-[2]-[3]-[4]-[5]	Absolute	200	20	100 ~ 1200	1 ~ 1000	40	12	9	4	169.5	0.02 [0.01]
ISDA [ISPDA]-L-[1]-200-10-[2]-[3]-[4]-[5]	Incremental		10		1 ~ 500	80	40	19	14	340.1	

* In the above model names, [1] indicates the encoder type, [2] the stroke, [3] the applicable controller, [4] the cable length, and [5] the applicable options.

Options

Name	Code	Page	Remarks
AQ seal	AQ	→P22	
Brake	B	→P22	
Reversed home specification	NM	→P22	
Guide with ball-retaining mechanism	RT	→P22	
Metal cable joint connector	EU	→Back,P2	

Common Specifications

Drive system (Note 4)	Ball screw ϕ 20mm, rolled C10 [equivalent to rolled C5]
Backlash (Note 5)	0.05mm or less [0.02mm or less]
Guide	Integrated with base
Allowable load moment	Ma: 104.9Nm, Mb: 149.9Nm, Mc: 248.9Nm
Overhang load length	Ma/Mb/Mc directions: 750mm or less
Base	Material: Aluminum with white alumite treatment
Applicable controller	T1: XSEL-KE/KT, E-Con; T2: XSEL-P/Q, SSEL, S-Con
Cable length (Note 6)	S: 3m, M: 5m, X□□: Length specification
Ambient operating temperature/humidity	0~40°C, 85%RH (non-condensing)

* Note that changing the home direction will require the actuator to be returned to IA1 for adjustment.

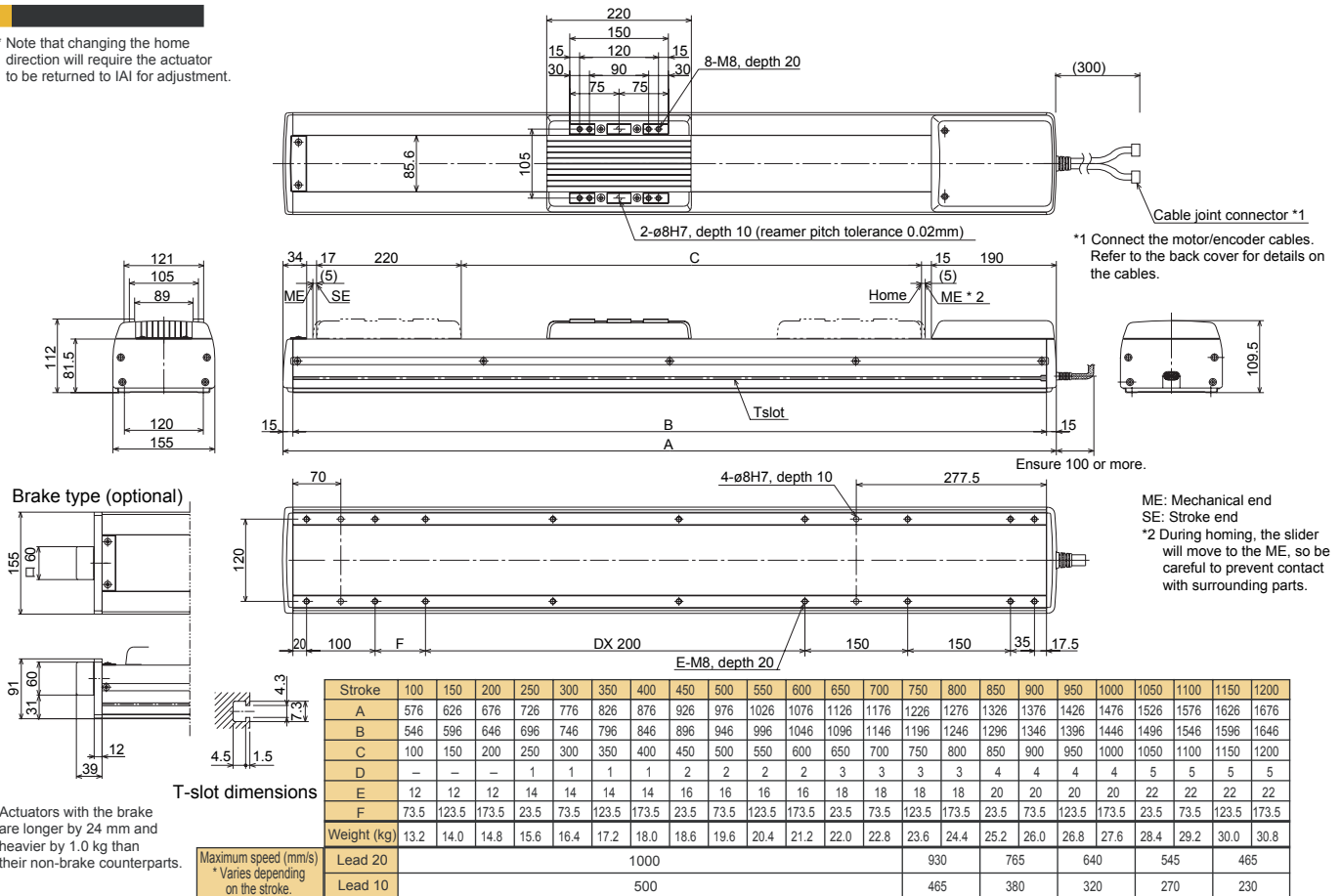

* Actuators with the brake are longer by 24 mm and heavier by 1.0 kg than their non-brake counterparts.

Maximum speed (mm/s)
* Varies depending on the stroke.

Applicable Controller Specifications

Applicable controller	Maximum number of controlled axes	Compatible encoder type	Operating method	Supply voltage	Maximum Output
X-SEL-P/Q	6 axes	Absolute / incremental	Program/ Positioner	1-phase 230VAC/ 3-phase 200VAC	1600W/ 2400W
X-SEL-KE/KT	4 axes			1600W	
S-SEL	2 axes			800W	
S-/E-Con	1 axis			750W	



(Note 1) When the stroke increases, the maximum speed drops in order to prevent the ball screw from reaching a dangerous speed. (Refer to the above table for the maximum speed at each stroke.)

(Note 2) Refer to page 22 for the relationship of acceleration and load capacity.

(Notes 3, 4, 5) The figures in [] apply to the ISPDA Series.

(Note 6) The maximum cable length is 30 m. Specify a desired length in meters. (Example: X08 = 8 m)

ISDA-L-400

Single-Axis Robot: Large Dust-proof Mid-support Type, Actuator Width 155mm, 400W, Straight Shape

ISPDA-L-400

Single-Axis Robot: Large Dust-proof Mid-support Type, Actuator Width 155mm, 400W, Straight Shape, High-Precision Specification

Type / Large dust-proof (155 mm wide) Stroke / 100~1200mm Load capacity / 80kg (horizontal)/19kg (vertical)

Model specification items Series Type Encoder type Motor output Lead Stroke Applicable controller Cable length Options

(Example) ISDA - L - A - 400 - 20 - 1200 - T1 - S - B

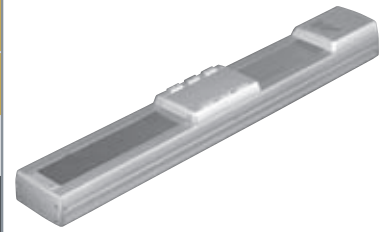

Model/Specifications

Model	Encoder Type	Motor output (W)	Lead (mm)	Stroke 50mm increments (mm)	Speed (mm/s) (Note 1)	Load capacity (Note2)				Rated thrust (N)	Positioning repeatability (mm) (Note 3)
						Horizontal (kg)		Vertical (kg)			
						Rated acceleration	Maximum acceleration	Rated acceleration	Maximum acceleration		
ISDA [ISPDA]-L- ¹ 400-20- ² ³ - ⁴ ⁵	Absolute Incremental	400	20	100 ~ 1200	1 ~ 1000	80	24	19	10	340.1	0.02 [0.01]

* In the above model names, ¹ indicates the encoder type, ² the stroke, ³ the applicable controller, ⁴ the cable length, and ⁵ the applicable options.

Options

Name	Code	Page	Remarks
AQ seal	AQ	→P22	
Brake	B	→P22	
Reversed home specification	NM	→P22	
Guide with ball-retaining mechanism	RT	→P22	
Metal cable joint connector	EU	→Back,P2	

Common Specifications

Drive system (Note 4)	Ball screw ϕ 20mm, rolled C10 [equivalent to rolled C5]
Backlash (Note 5)	0.05mm or less [0.02mm or less]
Guide	Integrated with base
Allowable load moment	Ma: 104.9Nm, Mb: 149.9Nm, Mc: 248.9Nm
Overhang load length	Ma/Mb/Mc directions: 750mm or less
Base	Material: Aluminum with white alumite treatment
Applicable controller	T1: XSEL-KE/KT, E-Con; T2: XSEL-P/Q, SSEL, S-Con
Cable length (Note 6)	S: 3m, M: 5m, X□□: Length specification
Ambient operating temperature/humidity	0~40°C, 85%RH (non-condensing)

Dimensions

* Note that changing the home direction will require the actuator to be returned to IAI for adjustment.

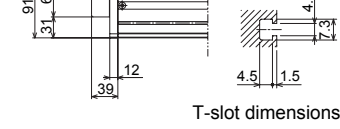
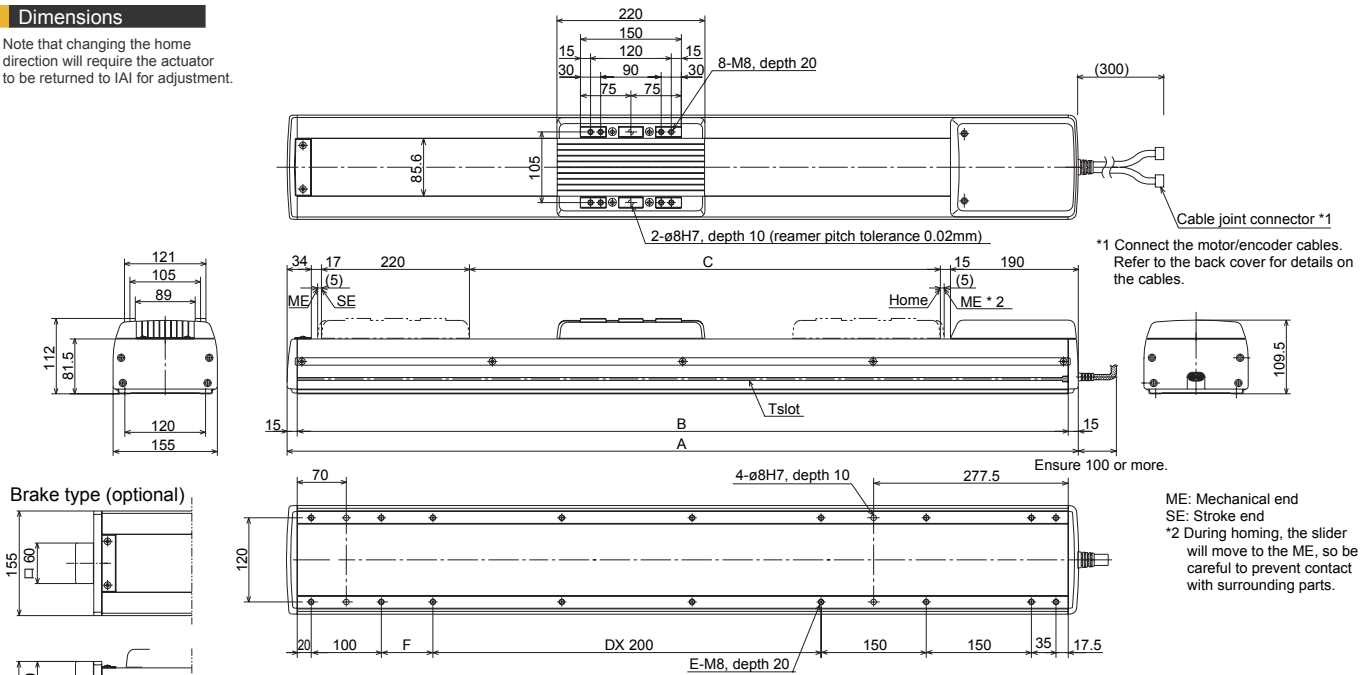

* Actuators with the brake are longer by 24 mm and heavier by 1.0 kg than their non-brake counterparts.

Stroke	100	150	200	250	300	350	400	450	500	550	600	650	700	750	800	850	900	950	1000	1050	1100	1150	1200
A	576	626	676	726	776	826	876	926	976	1026	1076	1126	1176	1226	1276	1326	1376	1426	1476	1526	1576	1626	1676
B	546	596	646	696	746	796	846	896	946	996	1046	1096	1146	1196	1246	1296	1346	1396	1446	1496	1546	1596	1646
C	100	150	200	250	300	350	400	450	500	550	600	650	700	750	800	850	900	950	1000	1050	1100	1150	1200
D	-	-	-	1	1	1	2	2	2	2	3	3	3	3	4	4	4	4	4	5	5	5	5
E	12	12	12	14	14	14	14	16	16	16	16	18	18	18	18	20	20	20	20	22	22	22	22
F	73.5	123.5	173.5	223.5	273.5	323.5	373.5	423.5	473.5	523.5	573.5	623.5	673.5	723.5	773.5	823.5	873.5	923.5	973.5	1023.5	1073.5	1123.5	1173.5
Weight (kg)	13.6	14.4	15.2	16.0	16.8	17.6	18.4	19.2	20.0	20.8	21.6	22.4	23.2	24.0	24.8	25.6	26.4	27.2	28.0	28.8	29.6	30.4	31.2
Lead 20	1000												930		765		640		545		465		

Applicable Controller Specifications

Applicable controller	Maximum number of controlled axes	Compatible encoder type	Operating method	Supply voltage	Maximum Output
X-SEL-P/Q	6 axes	Absolute /incremental	Program/ Positioner	1-phase 230VAC/ 3-phase 200VAC	1600W/ 2400W
X-SEL-KE/KT	4 axes			1-phase 100VAC/ 230VAC	1600W
S-SEL	2 axes				800W
S-E-Con	1 axis				750W



(Note 1) When the stroke increases, the maximum speed drops in order to prevent the ball screw from reaching a dangerous speed. (Refer to the above table for the maximum speed at each stroke.)
 (Note 2) Refer to page 22 for the relationship of acceleration and load capacity.
 (Notes 3, 4, 5) The figures in [] apply to the ISPDA Series.
 (Note 6) The maximum cable length is 30 m. Specify a desired length in meters. (Example: X08 = 8 m)

ISDA-LX-200 Single-Axis Robot: Large Dust-proof Mid-support Type, Actuator Width 155mm, 200W, Straight Shape

ISPDA-LX-200 Single-Axis Robot: Large Dust-proof Mid-support Type, Actuator Width 155mm, 200W, Straight Shape, High-Precision Specification

Type / Large dust-proof (155 mm wide) Mid-support Type Stroke / 1000~1600mm Load capacity / 40kg (horizontal)

Model specification items Series Type Encoder type Motor output Lead Stroke Applicable controller Cable length Options

(Example) ISDA - LX - A - 200 - 20 - 1600 - T1 - S - B

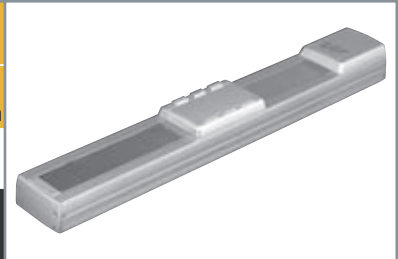

* Refer to page 1 for the details of model specification items.

Model/Specifications

Model	Encoder Type	Motor output (W)	Lead (mm)	Stroke 100mm increments (mm)	Speed (mm/s) (Note 1)	Load capacity (Note2)				Rated thrust (N)	Positioning repeatability (mm) (Note 3)
						Horizontal (kg)		Vertical (kg)			
						Rated acceleration	Maximum acceleration	Rated acceleration	Maximum acceleration		
ISDA [ISPDA]-LX-[1]-200-20-[2]-[3]-[4]	Absolute Incremental	200	20	1000 ~ 1600	1 ~ 1000	40		Horizontal only		169.5	0.02 [0.01]

* In the above model names, [1] indicates the encoder type, [2] the stroke, [3] the applicable controller, [4] the cable length, and [5] the applicable options.

Options

Name	Code	Page	Remarks
AQ seal	AQ	→P22	
Brake	B	→P22	
Reversed home specification	NM	→P22	
Guide with ball-retaining mechanism	RT	→P22	
Metal cable joint connector	EU	→Back,P2	

Common Specifications

Drive system (Note 4)	Ball screw ϕ 20mm, rolled C10 [equivalent to rolled C5]
Backlash (Note 5)	0.05mm or less [0.02mm or less]
Guide	Integrated with base
Allowable load moment	Ma: 104.9Nm, Mb: 149.9Nm, Mc: 248.9Nm
Overhang load length	Ma/Mb/Mc directions: 750mm or less
Base	Material: Aluminum with white alumite treatment
Applicable controller	T1: XSEL-KE/KT, E-Con; T2: XSEL-P/Q, SSEL, S-Con
Cable length (Note 6)	S: 3m, M: 5m, X□□: Length specification
Ambient operating temperature/humidity	0~40°C, 85%RH (non-condensing)

Dimensions

* Note that changing the home direction will require the actuator to be returned to IA1 for adjustment.

* Due to their structure, the mid-support type cannot be positioned horizontally on their side, or in vertical direction.

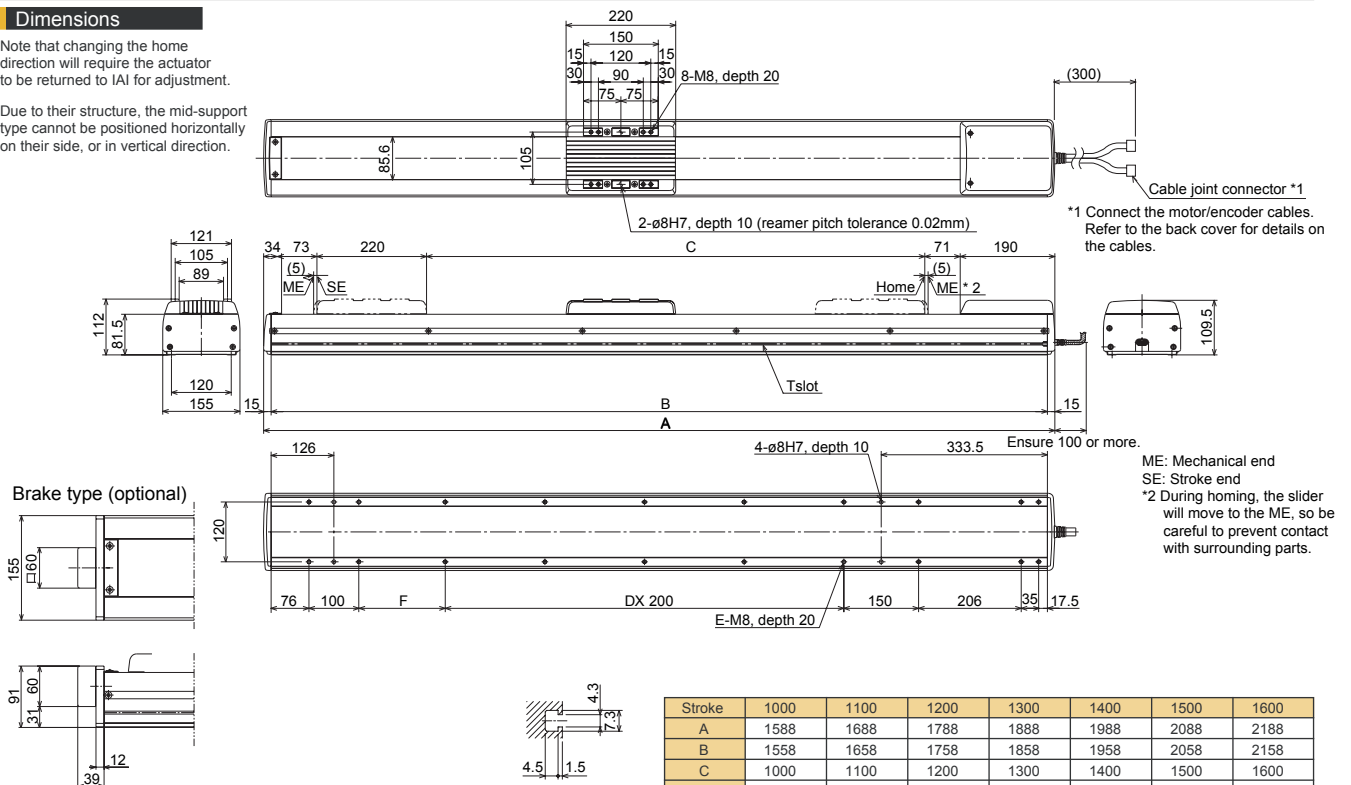

Brake type (optional)

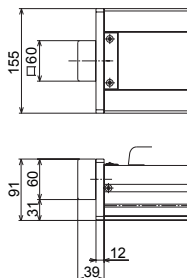

* Actuators with the brake are longer by 24 mm and heavier by 1.0 kg than their non-brake counterparts.

T-slot dimensions

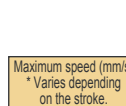

Stroke	1000	1100	1200	1300	1400	1500	1600
A	1588	1688	1788	1888	1988	2088	2188
B	1558	1658	1758	1858	1958	2058	2158
C	1000	1100	1200	1300	1400	1500	1600
D	4	5	5	6	6	7	7
E	20	22	22	24	24	26	26
F	173.5	73.5	173.5	73.5	173.5	73.5	173.5
Weight (kg)	30.8	32.4	34.0	35.6	37.2	38.9	40.5
Lead 20	1000					950	830

Applicable Controller Specifications

Applicable controller	Maximum number of controlled axes	Compatible encoder type	Operating method	Supply voltage	Maximum Output
X-SEL-P/Q	6 axes	Absolute /incremental	Program/ Positioner	1-phase 230VAC/ 3-phase 200VAC	1600W/ 2400W
X-SEL-KE/KT	4 axes			1-phase 100VAC/ 230VAC	1600W
S-SEL	2 axes				800W
S-/E-Con	1 axis				750W

Caution

(Note 1) When the stroke increases, the maximum speed drops in order to prevent the ball screw from reaching a dangerous speed. (Refer to the above table for the maximum speed at each stroke.)

(Note 2) Refer to page 22 for the relationship of acceleration and load capacity.

(Notes 3, 4, 5) The figures in [] apply to the ISPDA Series.

(Note 6) The maximum cable length is 30 m. Specify a desired length in meters. (Example: X08 = 8 m)

ISDA-LX-400 Single-Axis Robot: Large Dust-proof Mid-support Type, Actuator Width 155mm, 400W, Straight Shape

ISPDA-LX-400 Single-Axis Robot: Large Dust-proof Mid-support Type, Actuator Width 155mm, 400W, Straight Shape, High-Precision Specification

Type / Large dust-proof (155 mm wide) Mid-support Type Stroke / 1000~1600mm Load capacity / 80kg (horizontal)

Model specification items Series Type Encoder type Motor output Lead Stroke Applicable controller Cable length Options

(Example) ISDA - LX - A - 400 - 20 - 1600 - T1 - S - B

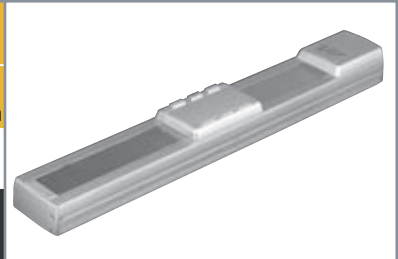

* Refer to page 1 for the details of model specification items.

Model/Specifications

Model	Encoder Type	Motor output (W)	Lead (mm)	Stroke 100mm increments (mm)	Speed (mm/s) (Note 1)	Load capacity (Note2)				Rated thrust (N)	Positioning repeatability (mm) (Note 3)
						Horizontal (kg)		Vertical (kg)			
						Rated acceleration	Maximum acceleration	Rated acceleration	Maximum acceleration		
ISDA [ISPDA]-LX- <u>1</u> -400-20- <u>2</u> - <u>3</u> - <u>3</u> - <u>3</u>	Absolute Incremental	400	20	1000 ~ 1600	1 ~ 1000	80	Horizontal only	340.1	0.02 [0.01]		

* In the above model names, 1 indicates the encoder type, 2 the stroke, 3 the applicable controller, 3 the cable length, and 3 the applicable options.

Options

Name	Code	Page	Remarks
AQ seal	AQ	→P22	
Brake	B	→P22	
Reversed home specification	NM	→P22	
Guide with ball-retaining mechanism	RT	→P22	
Metal cable joint connector	EU	→Back,P2	

Common Specifications

Drive system (Note 4)	Ball screw ϕ 20mm, rolled C10 [equivalent to rolled C5]
Backlash (Note 5)	0.05mm or less [0.02mm or less]
Guide	Integrated with base
Allowable load moment	Ma: 104.9Nm, Mb: 149.9Nm, Mc: 248.9Nm
Overhang load length	Ma/Mb/Mc directions: 750mm or less
Base	Material: Aluminum with white alumite treatment
Applicable controller	T1: XSEL-KE/KT, E-Con; T2: XSEL-P/Q, SSEL, S-Con
Cable length (Note 6)	S: 3m, M: 5m, X□□: Length specification
Ambient operating temperature/humidity	0~40°C, 85%RH (non-condensing)

Dimensions

* Note that changing the home direction will require the actuator to be returned to IAI for adjustment.

* Due to their structure, the mid-support type cannot be positioned horizontally on their side, or in vertical direction.

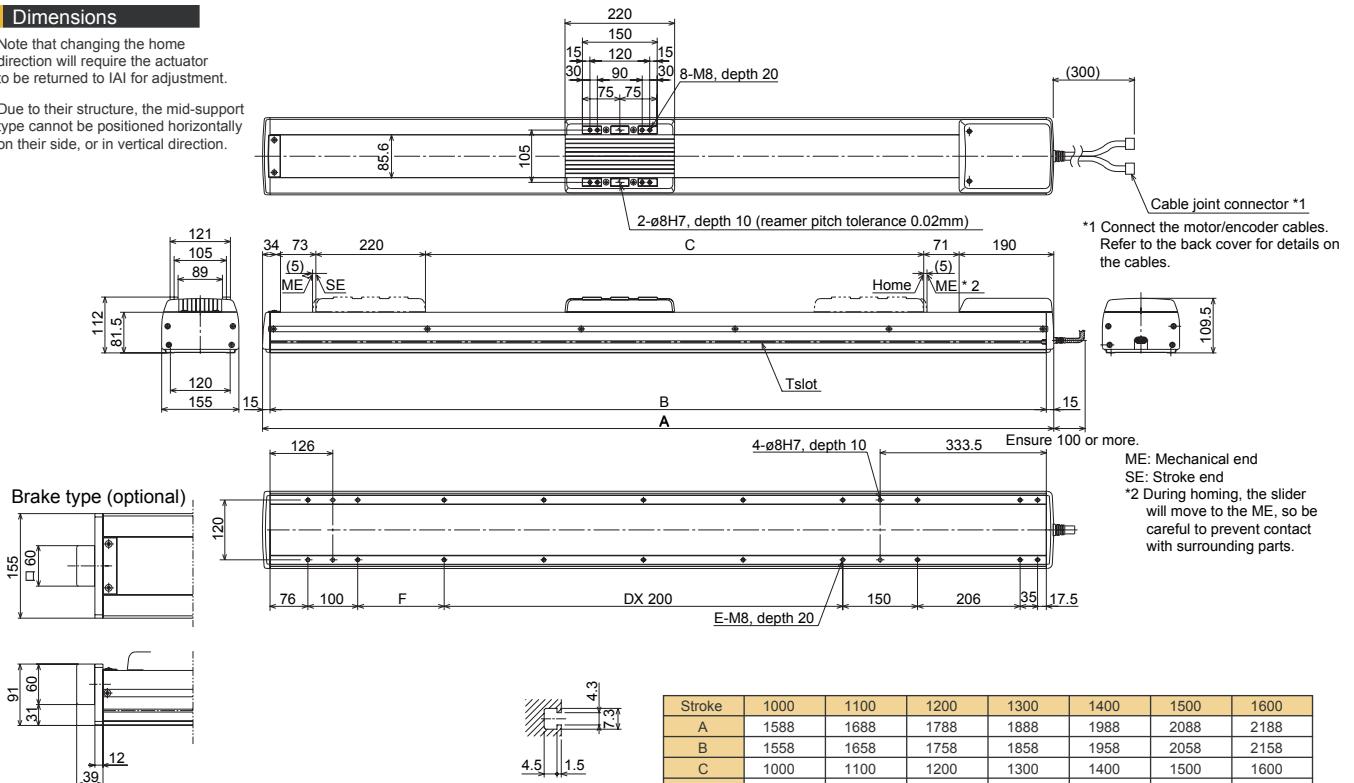

*1 Connect the motor/encoder cables. Refer to the back cover for details on the cables.

ME: Mechanical end
SE: Stroke end
*2 During homing, the slider will move to the ME, so be careful to prevent contact with surrounding parts.

Brake type (optional)

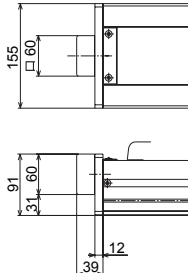

* Actuators with the brake are longer by 24 mm and heavier by 1.0 kg than their non-brake counterparts.

T-slot dimensions

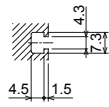

Stroke	1000	1100	1200	1300	1400	1500	1600
A	1588	1688	1788	1888	1988	2088	2188
B	1558	1658	1758	1858	1958	2058	2158
C	1000	1100	1200	1300	1400	1500	1600
D	4	5	5	6	6	7	7
E	20	22	22	24	24	26	26
F	173.5	73.5	173.5	73.5	173.5	73.5	173.5
Weight (kg)	31.2	32.8	34.4	36.0	37.6	39.2	40.8
Lead 20	1000					950	830

Maximum speed (mm/s)
* Varies depending on the stroke.

Applicable Controller Specifications

Applicable controller	Maximum number of controlled axes	Compatible encoder type	Operating method	Supply voltage	Maximum Output
X-SEL-P/Q	6 axes	Absolute /incremental	Program/ Positioner	1-phase 230VAC/ 3-phase 200VAC	1600W/ 2400W
X-SEL-KE/KT	4 axes			1600W	
S-SEL	2 axes			800W	
S/E-Con	1 axis		Positioner/ Pulse train		750W



(Note 1) When the stroke increases, the maximum speed drops in order to prevent the ball screw from reaching a dangerous speed. (Refer to the above table for the maximum speed at each stroke.)
(Note 2) Refer to page 22 for the relationship of acceleration and load capacity.
(Notes 3, 4, 5) The figures in [] apply to the ISPDA Series.
(Note 6) The maximum cable length is 30 m. Specify a desired length in meters. (Example: X08 = 8 m)

ISDACR-S Single-Axis Robot: Compact Cleanroom Type
Actuator Width 94mm, 60W, Straight Shape

ISPDACR-S Single-Axis Robot: Compact Cleanroom Type
Actuator Width 94mm, 60W, Straight Shape, High-Precision Specification

Type/Compact (94 mm wide) Stroke/100~600mm Load capacity/50kg (horizontal)/14kg (vertical)

Model specification items Series Type Encoder type Motor output Lead Stroke Applicable controller Cable length Options

(Example) ISDACR-S - A - 60 - 16 - 600 - T1 - S - B



* Refer to page 1 for the details of model specification items.

Model/Specifications

Model	Encoder Type	Motor output (W)	Lead (mm)	Stroke 50mm increments (mm)	Speed (mm/s) (Note 1)	Load capacity (Note 2)				Rated thrust (N)	Positioning repeatability (mm) (Note 3)	Suction rate (Nℓ/min)
						Horizontal (kg)		Vertical (kg)				
						Rated acceleration	Maximum acceleration	Rated acceleration	Maximum acceleration			
ISDACR [ISPDACR]-S-[1]-60-16-[2]-[3]-[4]-[5]	Absolute	60	16	100 ~ 600	1 ~ 800	12	3.5	3	2	63.7	0.02 [0.01]	30
ISDACR [ISPDACR]-S-[1]-60-8-[2]-[3]-[4]-[5]	Incremental		8		1 ~ 400	25	12	6	5	127.4		20
ISDACR [ISPDACR]-S-[1]-60-4-[2]-[3]-[4]-[5]			4		1 ~ 200	50	30	14	12	254.8		10

* In the above model names, [1] indicates the encoder type, [2] the stroke, [3] the applicable controller, [4] the cable length, and [5] the applicable options.

Options

Name	Code	Page	Remarks
AQ seal	AQ	→P22	
Brake	B	→P22	
Anti-electrostatic specification	ESD	→P22	
Reversed home specification	NM	→P22	
Guide with ball-retaining mechanism	RT	→P22	
Suction duct joint on opposite side	VR	→Back	
Metal cable joint connector	EU	→Back,P2	

Common Specifications

Drive system (Note 4)	Ball screw ø2mm, rolled C10 [equivalent to rolled C5]
Backlash (Note 5)	0.05mm or less [0.02mm or less]
Guide	Integrated with base
Grease	Low dust raising grease (for both ball screw and guide)
Allowable load moment	Ma: 28.4Nm, Mb: 40.2Nm, Mc: 65.7Nm
Overhang load length	Ma/Mb/Mc directions: 450mm or less
Base	Material: Aluminum with white alumite treatment
Applicable controller	T1: XSEL-KE/KT, E-Con; T2: XSEL-P/Q, SSEL, S-Con
Cable length (Note 6)	S: 3m, M: 5m, X□□: Length specification
Cleanliness level	Conforming to ISO Class 4 (0.1µm)
Suction duct joint	Quick duct joint with applicable outer tube diameter of ø12

Dimensions

* Note that changing the home direction will require the actuator to be returned to IAI for adjustment.

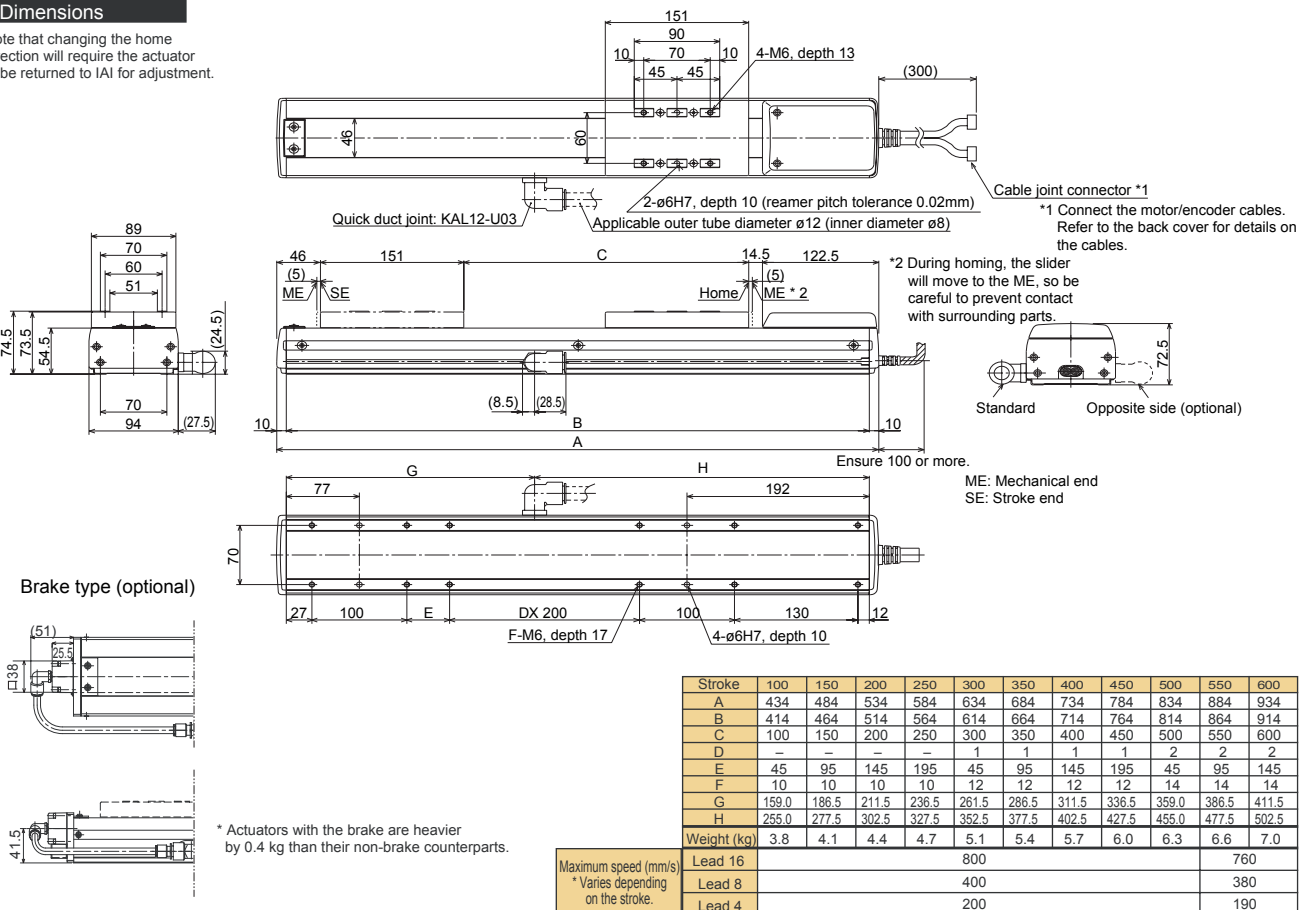

Applicable Controller Specifications

Applicable controller	Maximum number of controlled axes	Compatible encoder type	Operating method	Supply voltage	Maximum Output
X-SEL-P/Q	6 axes	Absolute /incremental	Program/ Positioner	1-phase 230VAC/ 3-phase 200VAC	1600W/ 2400W
X-SEL-KE/KT	4 axes			1600W	
S-SEL	2 axes			800W	
S-/E-Con	1 axis			750W	



(Note 1) When the stroke increases, the maximum speed drops in order to prevent the ball screw from reaching a dangerous speed. (Refer to the above table for the maximum speed at each stroke.)

(Note 2) Refer to page 22 for the relationship of acceleration and load capacity.

(Notes 3, 4, 5) The figures in [] apply to the ISPDACR Series.

(Note 6) The maximum cable length is 30 m. Specify a desired length in meters. (Example: X08 = 8 m)

ISDACR-M-100

Single-Axis Robot: Medium Cleanroom Type
Actuator Width 125mm, 100W, Straight Shape

ISPDACR-M-100

Single-Axis Robot: Medium Cleanroom Type
Actuator Width 125mm, 100W, Straight Shape, High-Precision Specification

Type / Medium (125 mm wide)

Stroke / 100~1000mm

Load capacity / 80kg (horizontal)/19kg (vertical)

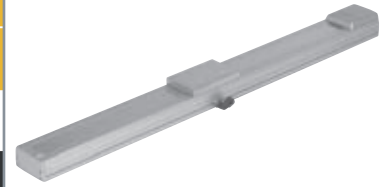

Model specification items Series Type Encoder type Motor output Lead Stroke Applicable controller Cable length Options

(Example) ISDACR- M - A - 100 - 20 -1000- T1 - S - B

* Refer to page 1 for the details of model specification items.

Model/Specifications

Model	Encoder Type	Motor output (W)	Lead (mm)	Stroke 50mm increments (mm)	Speed (mm/s) (Note 1)	Load capacity (Note 2)				Rated thrust (N)	Positioning repeatability (mm) (Note 3)	Suction rate (Nℓ/min)
						Horizontal (kg)		Vertical (kg)				
						Rated acceleration	Maximum acceleration	Rated acceleration	Maximum acceleration			
ISDACR [ISPDACR]-M-[1]-100-20-[2]-[3]-[4]-[5]	Absolute Incremental	100	20	100 ~ 1000	1 ~ 1000	20	6	3.5	2	84.3	0.02 [0.01]	70
ISDACR [ISPDACR]-M-[1]-100-10-[2]-[3]-[4]-[5]			10		1 ~ 500	40	20	9	7	169.5		30
ISDACR [ISPDACR]-M-[1]-100-5-[2]-[3]-[4]-[5]			5		1 ~ 250	80	45	19	15	340.1		15

* In the above model names, [1] indicates the encoder type, [2] the stroke, [3] the applicable controller, [4] the cable length, and [5] the applicable options.

Options

Name	Code	Page	Remarks
AQ seal	AQ	→P22	
Brake	B	→P22	
Anti-electrostatic specification	ESD	→P22	
Reversed home specification	NM	→P22	
Guide with ball-retaining mechanism	RT	→P22	
Suction duct joint on opposite side	VR	→Back	
Metal cable joint connector	EU	→Back,P2	

Common Specifications

Drive system (Note 4)	Ball screw ϕ 16mm, rolled C10 [equivalent to rolled C5]
Backlash (Note 5)	0.05mm or less [0.02mm or less]
Guide	Integrated with base
Grease	Low dust raising grease (for both ball screw and guide)
Allowable load moment	Ma: 69.6Nm, Mb: 99.0Nm, Mc: 161.7Nm
Overhang load length	Ma/Mb/Mc directions: 600mm or less
Base	Material: Aluminum with white alumite treatment
Applicable controller	T1: XSEL-KE/KT, E-Con; T2: XSEL-P/Q, SSEL, S-Con
Cable length (Note 6)	S: 3m, M: 5m, X□□: Length specification
Cleanliness level	Conforming to ISO Class 4 (0.1 μ m)
Suction duct joint	Quick duct joint with applicable outer tube diameter of ϕ 12

Dimensions

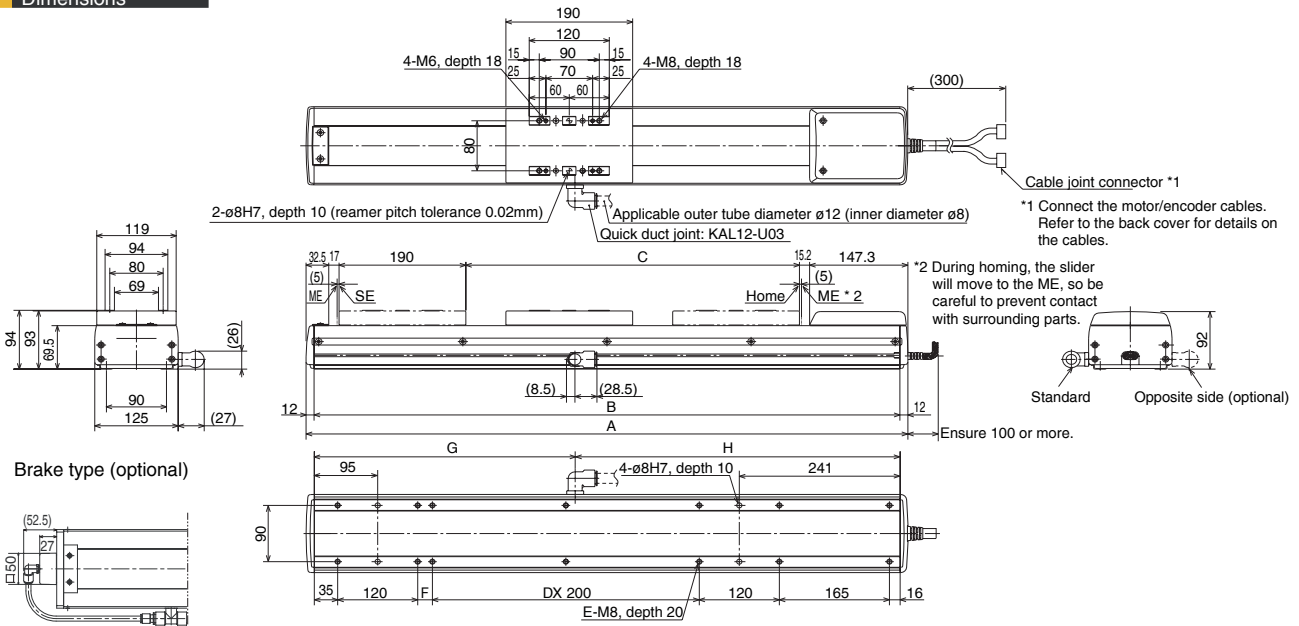

* Actuators with the brake are heavier by 0.7 kg than their non-brake counterparts.

Stroke	100	150	200	250	300	350	400	450	500	550	600	650	700	750	800	850	900	950	1000									
A	502	552	602	652	702	752	802	852	902	952	1002	1052	1102	1152	1202	1252	1302	1352	1402									
B	478	528	578	628	678	728	778	828	878	928	978	1028	1078	1128	1178	1228	1278	1328	1378									
C	100	150	200	250	300	350	400	450	500	550	600	650	700	750	800	850	900	950	1000									
D	-	-	-	-	1	1	1	1	2	2	2	2	3	3	3	3	4	4	4									
E	10	10	10	10	12	12	12	12	14	14	14	14	16	16	16	16	18	18	18									
F	22	72	122	172	22	72	122	172	22	72	122	172	22	72	122	172	12	72	122									
G	191	213	240	265	290	315	340	365	391	413	440	465	490	515	540	565	591	613	640									
H	287	315	338	363	388	413	438	463	487	515	538	563	588	613	638	663	687	715	738									
Weight (kg)	8.2	8.8	9.3	9.9	10.5	11.1	11.6	12.2	12.7	13.3	13.9	14.5	15.0	15.6	16.1	16.7	17.3	17.9	18.4									
Maximum speed (mm/s) * Varies depending on the stroke.	Lead 20	1000											915				735				600				500			
	Lead 10	500											455				365				300				250			
	Lead 5	250											225				180				150				125			

Applicable Controller Specifications

Applicable controller	Maximum number of controlled axes	Compatible encoder type	Operating method	Supply voltage	Maximum Output
X-SEL-P/Q	6 axes	Absolute /incremental	Program/ Positioner	1-phase 230VAC/ 3-phase 200VAC	1600W/ 2400W
X-SEL-KE/KT	4 axes			1600W	
S-SEL	2 axes			1-phase 100VAC/ 230VAC	800W
S-E-Con	1 axis			Positioner/ Pulse train	750W



(Note 1) When the stroke increases, the maximum speed drops in order to prevent the ball screw from reaching a dangerous speed. (Refer to the above table for the maximum speed at each stroke.)
 (Note 2) Refer to page 22 for the relationship of acceleration and load capacity.
 (Notes 3, 4, 5) The figures in [] apply to the ISPDACR Series.
 (Note 6) The maximum cable length is 30 m. Specify a desired length in meters. (Example: X08 = 8 m)

ISDACR-M-200 Single-Axis Robot: Medium Cleanroom Type Actuator Width 125mm, 200W, Straight Shape

ISPDACR-M-200 Single-Axis Robot: Medium Cleanroom Type Actuator Width 125mm, 200W, Straight Shape, High-Precision Specification

Type / Medium (125 mm wide) Stroke / 100~1000mm Load capacity / 80kg (horizontal)/19kg (vertical)

Model specification items Series Type Encoder type Motor output Lead Stroke Applicable controller Cable length Options

(Example) ISDACR- M - A - 200 - 20 -1000- T1 - S - B

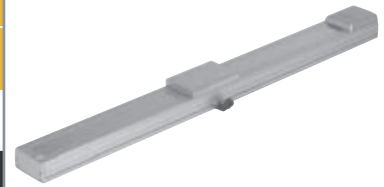

* Refer to page 1 for the details of model specification items.

Model/Specifications

Model	Encoder Type	Motor output (W)	Lead (mm)	Stroke 50mm increments (mm)	Speed (mm/s) (Note 1)	Load capacity (Note 2)				Rated thrust (N)	Positioning repeatability (mm) (Note 3)	Suction rate (Nℓ/min)
						Horizontal (kg)		Vertical (kg)				
						Rated acceleration	Maximum acceleration	Rated acceleration	Maximum acceleration			
ISDACR [ISPDACR]-M-[1]-200-20-[2]-[3]-[4]-[5]	Absolute	200	20	100 ~ 1000	1 ~ 1000	40	12	9	5	169.5	0.02	70
ISDACR [ISPDACR]-M-[1]-200-10-[2]-[3]-[4]-[5]	Incremental		10		1 ~ 500	80	40	19	15	340.1	[0.01]	30

* In the above model names, [1] indicates the encoder type, [2] the stroke, [3] the applicable controller, [4] the cable length, and [5] the applicable options.
* We accept a lead 30 specification as a custom order.

Options

Name	Code	Page	Remarks
AQ seal	AQ	→P22	
Brake	B	→P22	
Anti-electrostatic specification	ESD	→P22	
Reversed home specification	NM	→P22	
Guide with ball-retaining mechanism	RT	→P22	
Suction duct joint on opposite side	VR	→Back	
Metal cable joint connector	EU	→Back,P2	

Common Specifications

Drive system (Note 4)	Ball screw ϕ 16mm, rolled C10 [equivalent to rolled C5]
Backlash (Note 5)	0.05mm or less [0.02mm or less]
Guide	Integrated with base
Grease	Low dust raising grease (for both ball screw and guide)
Allowable load moment	Ma: 69.6Nm, Mb: 99.0Nm, Mc: 161.7Nm
Overhang load length	Ma/Mb/Mc directions: 600mm or less
Base	Material: Aluminum with white alumite treatment
Applicable controller	T1: XSEL-KE/KT, E-Con; T2: XSEL-P/Q, SSEL, S-Con
Cable length (Note 6)	S: 3m, M: 5m, X□□: Length specification
Cleanliness level	Conforming to ISO Class 4 (0.1 μ m)
Suction duct joint	Quick duct joint with applicable outer tube diameter of ϕ 12

Dimensions

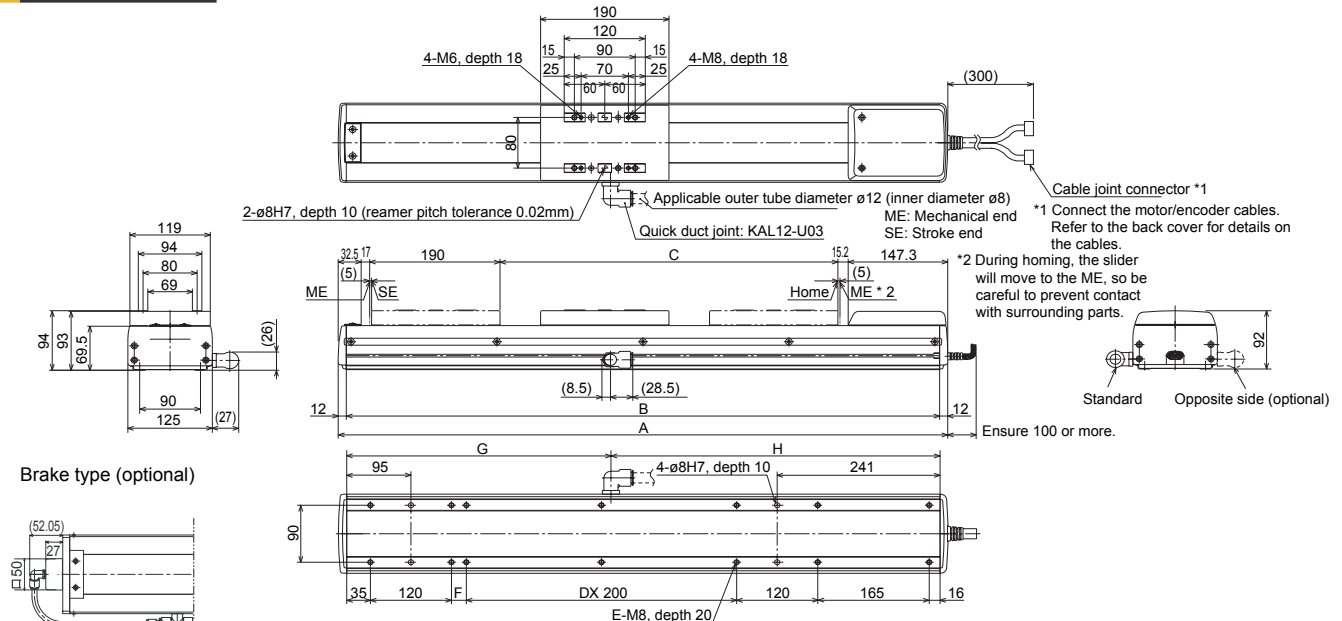

Brake type (optional)

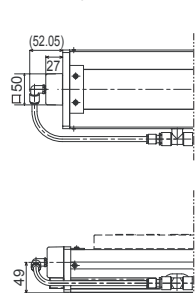

* Actuators with the brake are heavier by 0.7 kg than their non-brake counterparts.

Stroke	Maximum speed (mm/s) * Varies depending on the stroke.																		
	Lead 20	Lead 10	Lead 5	Lead 2.5	Lead 1.25	Lead 0.625	Lead 0.3125	Lead 0.15625	Lead 0.078125	Lead 0.0390625	Lead 0.01953125	Lead 0.009765625							
100	8.4	9.0	9.6	10.2	10.7	11.3	11.9	12.5	13.0	13.6	14.1	15.7	15.3	15.9	16.4	17.0	17.5	18.1	18.7

Applicable Controller Specifications

Applicable controller	Maximum number of controlled axes	Compatible encoder type	Operating method	Supply voltage	Maximum Output
X-SEL-P/Q	6 axes	Absolute /incremental	Program/ Positioner	1-phase 230VAC/ 3-phase 200VAC	1600W/ 2400W
X-SEL-KE/KT	4 axes			1-phase 100VAC/ 230VAC	1600W
S-SEL	2 axes				800W
S-/E-Con	1 axis				750W



(Note 1) When the stroke increases, the maximum speed drops in order to prevent the ball screw from reaching a dangerous speed. (Refer to the above table for the maximum speed at each stroke.)
(Note 2) Refer to page 22 for the relationship of acceleration and load capacity.
(Notes 3, 4, 5) The figures in [] apply to the ISPDACR Series.
(Note 6) The maximum cable length is 30 m. Specify a desired length in meters. (Example: X08 = 8 m)

ISDACR-MX-200

Single-Axis Robot: Medium Cleanroom Mid-support Type
Actuator Width 125mm, 200W, Straight Shape

ISPDACR-MX-200

Single-Axis Robot Medium Cleanroom Mid-support Type
Actuator Width 125mm, 200W, Straight Shape, High-Precision Specification

Type	Medium (125 mm wide) Mid-support Type	Stroke	800~2000mm	Load capacity	40kg (horizontal)
------	--	--------	------------	---------------	-------------------

Model specification items Series Type Encoder type Motor output Lead Stroke Applicable controller Cable length Options

(Example) ISDACR-MX-A-200-20-2000-T1-S-B

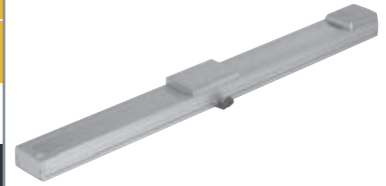

* Refer to page 1 for the details of model specification items.

Model/Specifications

Model	Encoder Type	Motor output (W)	Lead (mm)	Stroke 100mm increments (mm)	Speed (mm/s) (Note 1)	Load capacity (Note 2)				Rated thrust (N)	Positioning repeatability (mm) (Note 3)	Suction rate (Nℓ/min)
						Horizontal (kg)		Vertical (kg)				
						Rated acceleration	Maximum acceleration	Rated acceleration	Maximum acceleration			
ISDACR [ISPDACR]-MX- ¹ 200-20- ² 20- ³ T1- ⁴ S- ⁵ B	Absolute Incremental	200	20	800 ~ 2000	1 ~ 1000	40	Horizontal only		169.5	0.02 [0.01]	70	

* In the above model names, ¹ indicates the encoder type, ² the stroke, ³ the applicable controller, ⁴ the cable length, and ⁵ the applicable options.

Options

Name	Code	Page	Remarks
AQ seal	AQ	→P22	
Brake	B	→P22	
Reversed home specification	NM	→P22	
Guide with ball-retaining mechanism	RT	→P22	
Suction duct joint on opposite side	VR	→Back	
Metal cable joint connector	EU	→Back, P2	

Common Specifications

Drive system (Note 4)	Ball screw ϕ 16mm, rolled C10 [equivalent to rolled C5]
Backlash (Note 5)	0.05mm or less [0.02mm or less]
Guide	Integrated with base
Grease	Low dust raising grease (for both ball screw and guide)
Allowable load moment	Ma: 69.6Nm, Mb: 99.0Nm, Mc: 161.7Nm
Overhang load length	Ma/Mb/Mc directions: 450mm or less
Base	Material: Aluminum with white alumite treatment
Applicable controller	T1: XSEL-KE/KT, E-Con; T2: XSEL-P/Q, SSEL, S-Con
Cable length (Note 6)	S: 3m, M: 5m, X□□: Length specification
Cleanliness level	Conforming to ISO Class 4 (0.1 μ m)
Suction duct joint	Quick duct joint with applicable outer tube diameter of ϕ 12

Dimensions

* Note that changing the home direction will require the actuator to be returned to IAI for adjustment.

* Due to their structure, the mid-support type cannot be positioned horizontally on their side, or in vertical direction.

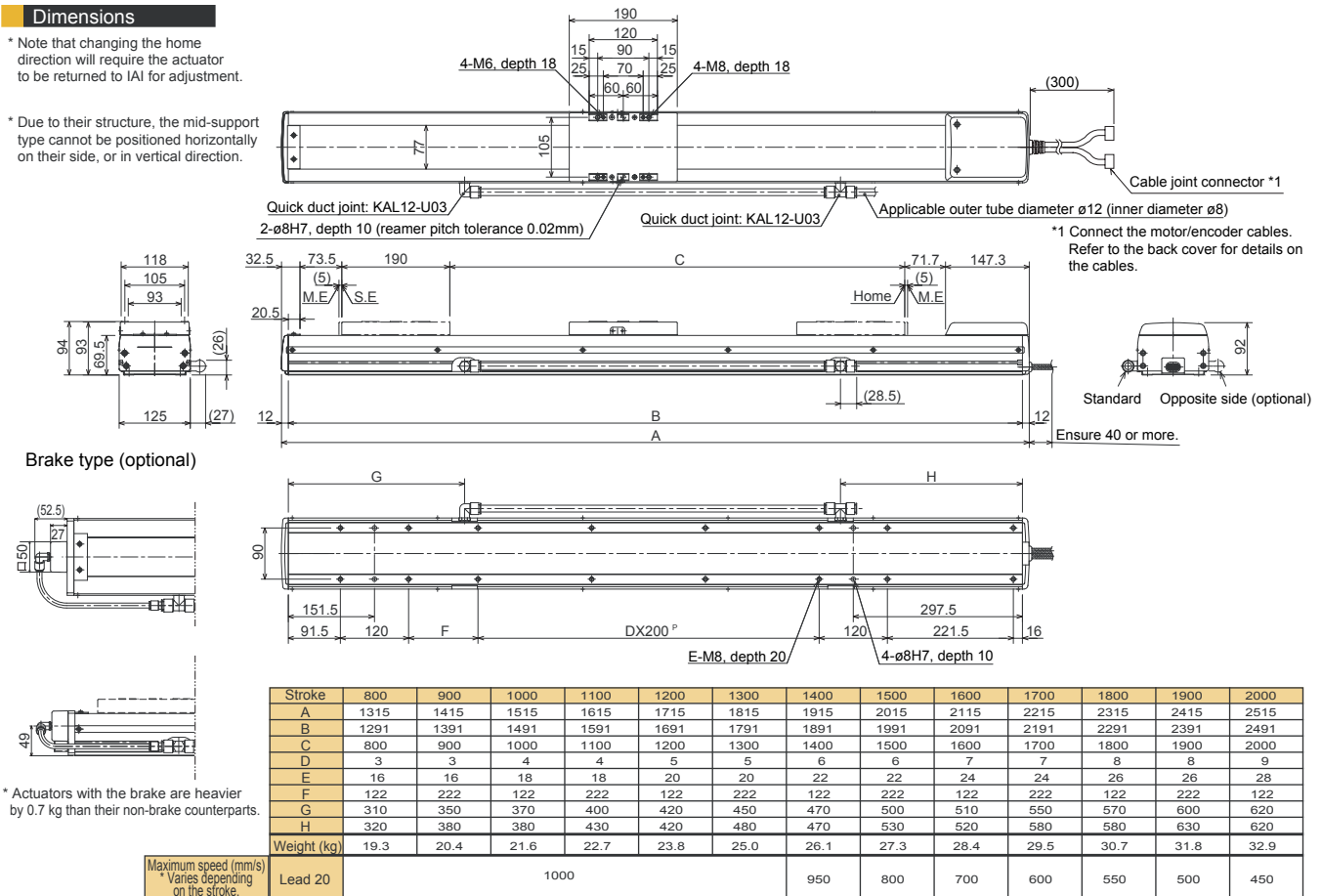

* Actuators with the brake are heavier by 0.7 kg than their non-brake counterparts.

Maximum speed (mm/s)
* Varies depending on the stroke.

Applicable Controller Specifications

Applicable controller	Maximum number of controlled axes	Compatible encoder type	Operating method	Supply voltage	Maximum Output
X-SEL-P/Q	6 axes	Absolute /incremental	Program/ Positioner	1-phase 230VAC/ 3-phase 200VAC	1600W/ 2400W
X-SEL-KE/KT	4 axes			1-phase 100VAC/ 230VAC	1600W
S-SEL	2 axes				800W
S-/E-Con	1 axis				750W



(Note 1) When the stroke increases, the maximum speed drops in order to prevent the ball screw from reaching a dangerous speed. (Refer to the above table for the maximum speed at each stroke.)
(Note 2) Refer to page 22 for the relationship of acceleration and load capacity.
(Notes 3, 4, 5) The figures in [] apply to the ISPDACR Series.
(Note 6) The maximum cable length is 30 m. Specify a desired length in meters. (Example: X08 = 8 m)

ISDACR-L-200 Single-Axis Robot: Large Cleanroom Type Actuator Width 155mm, 200W, Straight Shape

ISPDACR-L-200 Single-Axis Robot: Large Cleanroom Type Actuator Width 155mm, 200W, Straight Shape, High-Precision Specification



Type / Large (155 mm wide) Stroke / 100~1200mm Load capacity / 80kg (horizontal)/19kg (vertical)

Model specification items Series Type Encoder type Motor output Lead Stroke Applicable controller Cable length Options
 (Example) ISDACR-L-A-200-20-1200-T1-S-B

* Refer to page 1 for the details of model specification items.

Model/Specifications

Model	Encoder Type	Motor output (W)	Lead (mm)	Stroke 50mm increments (mm)	Speed (mm/s) (Note 1)	Load capacity (Note 2)				Rated thrust (N)	Positioning repeatability (mm) (Note 3)	Suction rate (Nl/min)
						Horizontal (kg)		Vertical (kg)				
						Rated acceleration	Maximum acceleration	Rated acceleration	Maximum acceleration			
ISDACR [ISPDACR]-L- <u>1</u> -200- <u>20</u> - <u>1200</u> - <u>T1</u> - <u>S</u> - <u>B</u>	Absolute	200	20	100 ~ 1200	1 ~ 1000	40	12	9	4	169.5	0.02	90
ISDACR [ISPDACR]-L- <u>1</u> -200-10- <u>1200</u> - <u>T1</u> - <u>S</u> - <u>B</u>	Incremental		10			1 ~ 500	80	40	19	14	340.1	[0.01]

* In the above model names, 1 indicates the encoder type, 2 the stroke, 3 the applicable controller, 4 the cable length, and 5 the applicable options.

Options

Name	Code	Page	Remarks
AQ seal	AQ	→P22	
Brake	B	→P22	
Anti-electrostatic specification	ESD	→P22	
Reversed home specification	NM	→P22	
Guide with ball-retaining mechanism	RT	→P22	
Suction duct joint on opposite side	VR	→Back	
Metal cable joint connector	EU	→Back, P2	

Common Specifications

Drive system (Note 4)	Ball screw ϕ 20mm, rolled C10 [equivalent to rolled C5]
Backlash (Note 5)	0.05mm or less [0.02mm or less]
Guide	Integrated with base
Grease	Low dust raising grease (for both ball screw and guide)
Allowable load moment	Ma: 104.9Nm, Mb: 149.9Nm, Mc: 248.9Nm
Overhang load length	Ma/Mb/Mc directions: 750mm or less
Base	Material: Aluminum with white alumite treatment
Applicable controller	T1: XSEL-KE/KT, E-Con; T2: XSEL-P/Q, SSEL, S-Con
Cable length (Note 6)	S: 3m, M: 5m, X□□: Length specification
Cleanliness level	Conforming to ISO Class 4 (0.1 μ m)
Suction duct joint	Quick duct joint with applicable outer tube diameter of ϕ 12

Dimensions

* Note that changing the home direction will require the actuator to be returned to IA1 for adjustment.

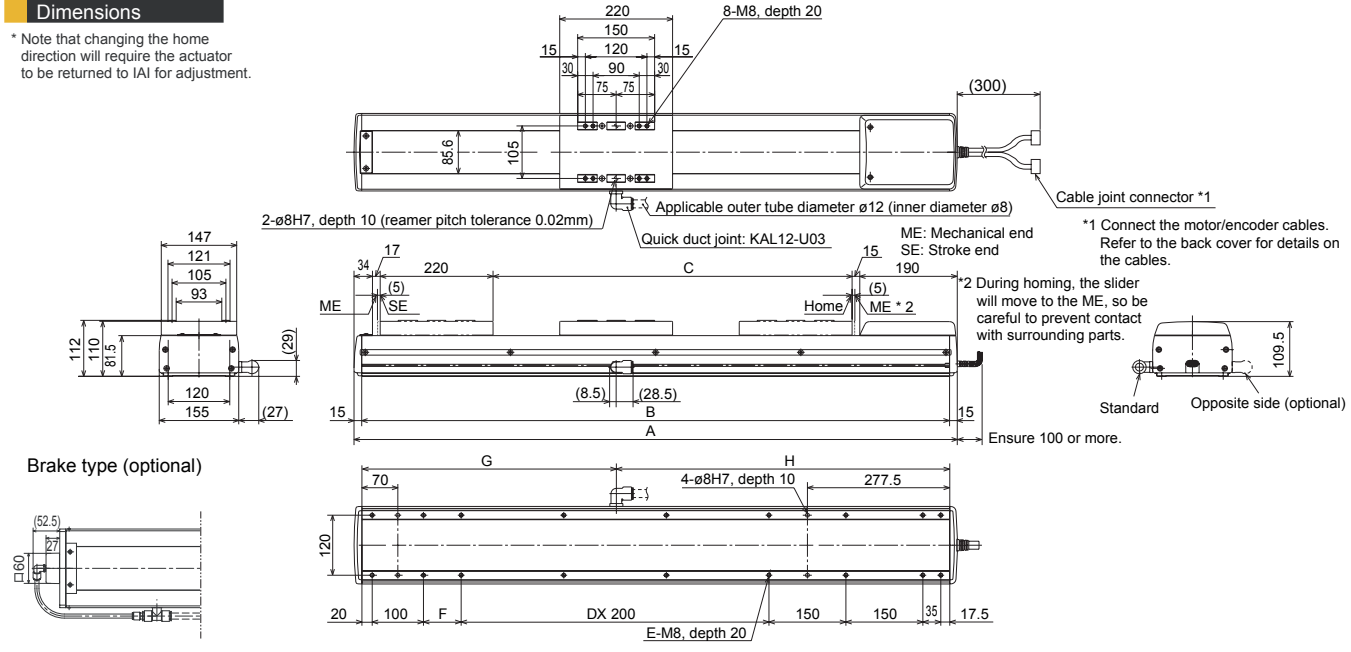

Brake type (optional)

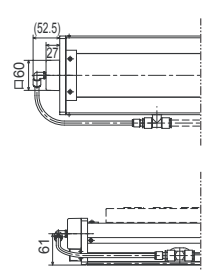

* Actuators with the brake are heavier by 1.1 kg than their non-brake counterparts.

Stroke	100	150	200	250	300	350	400	450	500	550	600	650	700	750	800	850	900	950	1000	1050	1100	1150	1200
A	576	626	676	726	776	826	876	926	976	1026	1076	1126	1176	1226	1276	1326	1376	1426	1476	1526	1576	1626	1676
B	546	596	646	696	746	796	846	896	946	996	1046	1096	1146	1196	1246	1296	1346	1396	1446	1496	1546	1596	1646
C	100	150	200	250	300	350	400	450	500	550	600	650	700	750	800	850	900	950	1000	1050	1100	1150	1200
D	-	-	-	1	1	1	1	2	2	2	2	3	3	3	3	4	4	4	4	5	5	5	5
E	12	12	12	14	14	14	14	16	16	16	16	18	18	18	18	20	20	20	20	22	22	22	22
F	73.5	123.5	173.5	23.5	73.5	123.5	173.5	23.5	73.5	123.5	173.5	23.5	73.5	123.5	173.5	23.5	73.5	123.5	173.5	23.5	73.5	123.5	173.5
G	179.5	221.0	246.0	271.0	296.0	321.0	346.0	371.0	379.5	421.0	446.0	471.0	496.0	521.0	546.0	571.0	579.5	621.0	646.0	671.0	696.0	721.0	746.0
H	366.5	375	400.0	425.0	450.0	475.0	500.0	525.0	566.5	575.0	600.0	625.0	650.0	675.0	700.0	725.0	766.5	775.0	800.0	825.0	850.0	875.0	900.0
Weight (kg)	13.2	14.0	14.8	15.6	16.4	17.2	18.0	18.8	19.6	20.4	21.2	22.0	22.8	23.6	24.4	25.2	26.0	26.8	27.6	28.4	29.2	30.0	30.8
Maximum speed (mm/s) * Varies depending on the stroke.	Lead 20											930	765	640	545	465							
	Lead 10											465	380	320	270	230							

Applicable Controller Specifications

Applicable controller	Maximum number of controlled axes	Compatible encoder type	Operating method	Supply voltage	Maximum Output
X-SEL-P/Q	6 axes	Absolute / incremental	Program/ Positioner	1-phase 230VAC/ 3-phase 200VAC	1600W/ 2400W
X-SEL-KE/KT	4 axes			1600W	
S-SEL	2 axes			800W	
S-/E-Con	1 axis			750W	

Caution

(Note 1) When the stroke increases, the maximum speed drops in order to prevent the ball screw from reaching a dangerous speed. (Refer to the above table for the maximum speed at each stroke.)

(Note 2) Refer to page 22 for the relationship of acceleration and load capacity.

(Notes 3, 4, 5) The figures in [] apply to the ISPDACR Series.

(Note 6) The maximum cable length is 30 m. Specify a desired length in meters. (Example: X08 = 8 m)

ISDACR-L-400

Single-Axis Robot: Large Cleanroom Type
Actuator Width 155mm, 400W, Straight Shape

ISPDACR-L-400

Single-Axis Robot: Large Cleanroom Type
Actuator Width 155mm, 400W, Straight Shape, High-Precision Specification

Type / Large (155 mm wide)

Stroke / 100~1200mm

Load capacity / 80kg (horizontal)/19kg (vertical)

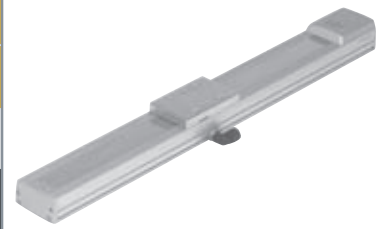

Model specification items Series Type Encoder type Motor output Lead Stroke Applicable controller Cable length Options

(Example) ISDACR - L - A - 400 - 20 - 1200 - T1 - S - B

* Refer to page 1 for the details of model specification items.

Model/Specifications

Model	Encoder Type	Motor output (W)	Lead (mm)	Stroke 50mm increments (mm)	Speed (mm/s) (Note 1)	Load capacity (Note 2)				Rated thrust (N)	Positioning repeatability (mm) (Note 3)	Suction rate (Nℓ/min)
						Horizontal (kg)		Vertical (kg)				
						Rated acceleration	Maximum acceleration	Rated acceleration	Maximum acceleration			
ISDACR [ISPDACR]-L-[1]-400-[2]-[3]-[4]-[5]	Absolute Incremental	400	20	100 ~ 1200	1 ~ 1000	80	24	19	10	340.1	0.02 [0.01]	90

*In the above model names, [1] indicates the encoder type, [2] the stroke, [3] the applicable controller, [4] the cable length, and [5] the applicable options.
*We accept a lead 30 specification as a custom order.

Options

Name	Code	Page	Remarks
AQ seal	AQ	→P22	
Brake	B	→P22	
Anti-electrostatic specification	ESD	→P22	The maximum supported stroke is 1000 mm.
Reversed home specification	NM	→P22	
Guide with ball-retaining mechanism	RT	→P22	
Suction duct joint on opposite side	VR	→Back	
Metal cable joint connector	EU	→Back,P2	

Common Specifications

Drive system (Note 4)	Ball screw $\phi 20$ mm, rolled C10 [equivalent to rolled C5]
Backlash (Note 5)	0.05mm or less [0.02mm or less]
Guide	Integrated with base
Grease	Low dust raising grease (for both ball screw and guide)
Allowable load moment	Ma: 104.9Nm, Mb: 149.9Nm, Mc: 248.9Nm
Overhang load length	Ma/Mb/Mc directions: 750mm or less
Base	Material: Aluminum with white alumite treatment
Applicable controller	T1: XSEL-KE/KT, E-Con; T2: XSEL-P/Q, SSEL, S-Con
Cable length (Note 6)	S: 3m, M: 5m, X□□: Length specification
Cleanliness level	Conforming to ISO Class 4 (0.1 μ m)
Suction duct joint	Quick duct joint with applicable outer tube diameter of $\phi 12$

Dimensions

* Note that changing the home direction will require the actuator to be returned to IAI for adjustment.

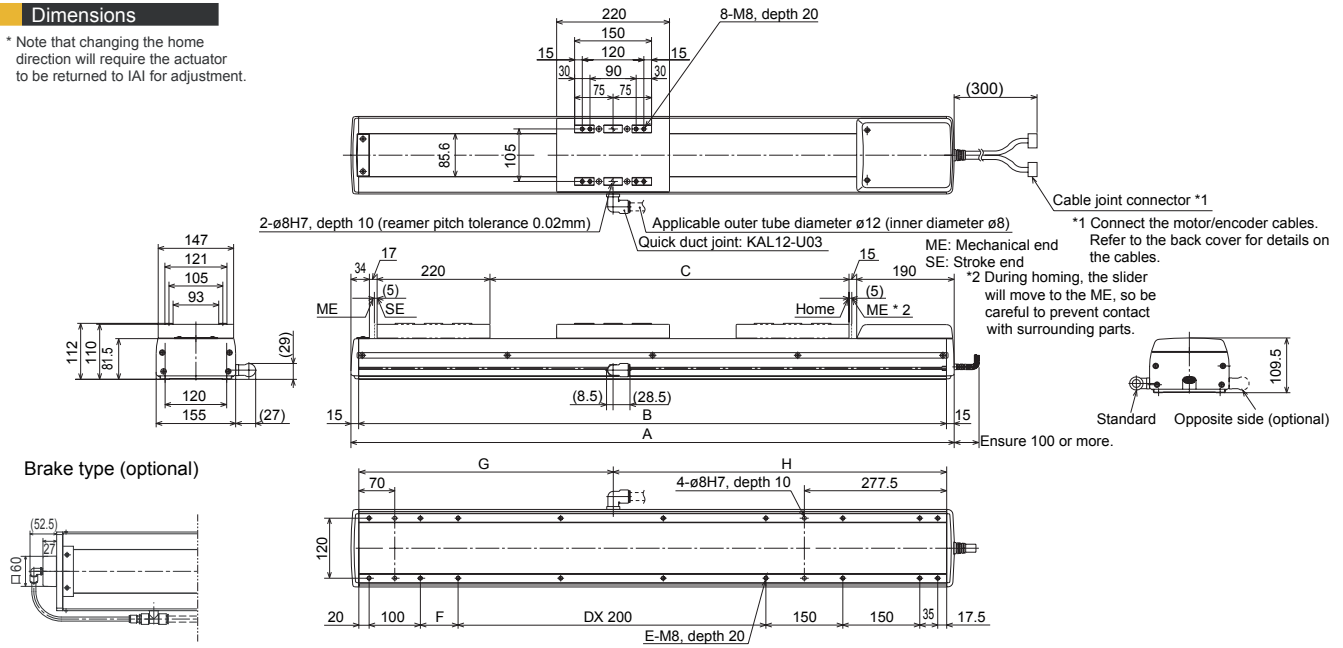

Brake type (optional)

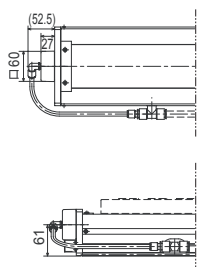

* Actuators with the brake are heavier by 1.1 kg than their non-brake counterparts.

Stroke	100	150	200	250	300	350	400	450	500	550	600	650	700	750	800	850	900	950	1000	1050	1100	1150	1200
A	576	626	676	726	776	826	876	926	976	1026	1076	1126	1176	1226	1276	1326	1376	1426	1476	1526	1576	1626	1676
B	546	596	646	696	746	796	846	896	946	996	1046	1096	1146	1196	1246	1296	1346	1396	1446	1496	1546	1596	1646
C	100	150	200	250	300	350	400	450	500	550	600	650	700	750	800	850	900	950	1000	1050	1100	1150	1200
D	-	-	-	1	1	1	1	2	2	2	2	3	3	3	3	4	4	4	4	5	5	5	5
E	12	12	12	14	14	14	14	16	16	16	18	18	18	18	18	20	20	20	20	22	22	22	22
F	73.5	123.5	173.5	223.5	273.5	323.5	373.5	423.5	473.5	523.5	573.5	623.5	673.5	723.5	773.5	823.5	873.5	923.5	973.5	1023.5	1073.5	1123.5	1173.5
G	179.5	221.0	246.0	271.0	296.0	321.0	346.0	371.0	379.5	421.0	446.0	471.0	496.0	521.0	546.0	571.0	579.5	621.0	646.0	671.0	696.0	721.0	746.0
H	366.5	375	400.0	425.0	450.0	475.0	500.0	525.0	566.5	575.0	600.0	625.0	650.0	675.0	700.0	725.0	766.5	775.0	800.0	825.0	850.0	875.0	900.0
Weight (kg)	13.6	14.4	15.2	16.0	16.8	17.6	18.4	19.2	20.0	20.8	21.6	22.4	23.2	24.0	24.8	25.6	26.4	27.2	28.0	28.8	29.6	30.4	31.2
Lead 20	1000															930	765	640	545	465			

Applicable Controller Specifications

Applicable controller	Maximum number of controlled axes	Compatible encoder type	Operating method	Supply voltage	Maximum Output
X-SEL-P/Q	6 axes	Absolute / incremental	Program/ Positioner	1-phase 230VAC/ 3-phase 200VAC	1600W/ 2400W
X-SEL-KE/KT	4 axes			1-phase 100VAC/ 230VAC	1600W
S-SEL	2 axes		Positioner/ Pulse train	800W	
S-E-Con	1 axis		750W		



(Note 1) When the stroke increases, the maximum speed drops in order to prevent the ball screw from reaching a dangerous speed. (Refer to the above table for the maximum speed at each stroke.)

(Note 2) Refer to page 22 for the relationship of acceleration and load capacity.

(Notes 3, 4, 5) The figures in [] apply to the ISPDACR Series.

(Note 6) The maximum cable length is 30 m. Specify a desired length in meters. (Example: X08 = 8 m)

ISDACR-LX-200

Single-Axis Robot: Large Cleanroom Mid-support Type
Actuator Width 155mm, 200W, Straight Shape

ISPDACR-LX-200

Single-Axis Robot: Large Cleanroom Mid-support Type
Actuator Width 155mm, 200W, Straight Shape, High-Precision Specification



Type / Large (155 mm wide) Mid-support Type Stroke / 1000-2500mm Load capacity / 40kg (horizontal)

Model specification items Series Type Encoder type Motor output Lead Stroke Applicable controller Cable length Options
(Example) ISDACR-LX - A - 200 - 20 - 2500 - T1 - S - B

* Refer to page 1 for the details of model specification items.

Model/Specifications

Model	Encoder Type	Motor output (W)	Lead (mm)	Stroke 100mm increments (mm)	Speed (mm/s) (Note 1)	Load capacity (Note 2)				Rated thrust (N)	Positioning repeatability (mm) (Note 3)	Suction rate (Nl/min)
						Horizontal (kg)		Vertical (kg)				
						Rated acceleration	Maximum acceleration	Rated acceleration	Maximum acceleration			
ISDACR [ISPDACR]-LX-[1]-[2]-[3]-[4]-[5]	Absolute Incremental	200	20	1000 ~ 2500	1 ~ 1000	40	Horizontal only		169.5	0.02 [0.01]	90	

* In the above model names, [1] indicates the encoder type, [2] the stroke, [3] the applicable controller, [4] the cable length, and [5] the applicable options.

Options

Name	Code	Page	Remarks
AQ seal	AQ	→P22	
Brake	B	→P22	
Reversed home specification	NM	→P22	
Guide with ball-retaining mechanism	RT	→P22	
Suction duct joint on opposite side	VR	→Back	
Metal cable joint connector	EU	→Back, P2	

Common Specifications

Drive system (Note 4)	Ball screw ϕ 20mm, rolled C10 [equivalent to rolled C5]
Backlash (Note 5)	0.05mm or less [0.02mm or less]
Guide	Integrated with base
Grease	Low dust raising grease (for both ball screw and guide)
Allowable load moment	Ma: 104.9Nm, Mb: 149.9Nm, Mc: 248.9Nm
Overhang load length	Ma/Mb/Mc directions: 750mm or less
Base	Material: Aluminum with white alumite treatment
Applicable controller	T1: XSEL-KE/KT, E-Con; T2: XSEL-P/Q, SSEL, S-Con
Cable length (Note 6)	S: 3m, M: 5m, X□□: Length specification
Cleanliness level	Conforming to ISO Class 4 (0.1 μ m)
Suction duct joint	Quick duct joint with applicable outer tube diameter of ϕ 12

Dimensions

* Note that changing the home direction will require the actuator to be returned to IAI for adjustment.

* Due to their structure, the mid-support type cannot be positioned horizontally on their side, or in vertical direction.

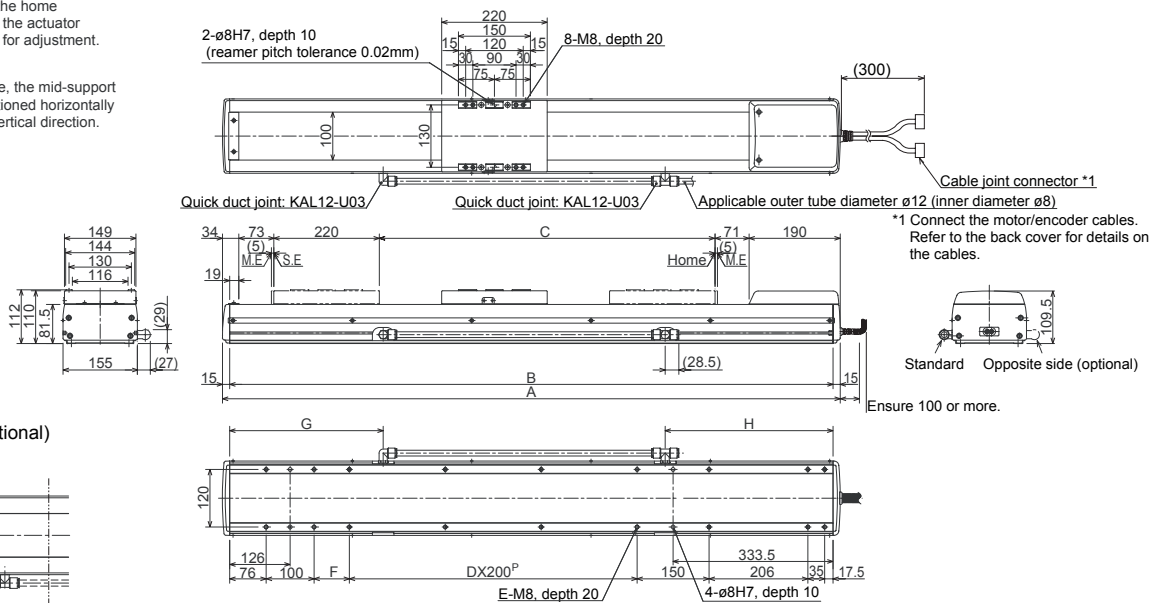

Brake type (optional)

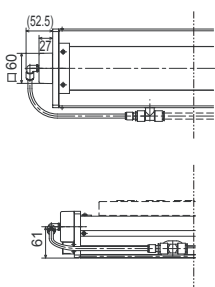

* Actuators with the brake are heavier by 1.1 kg than their non-brake counterparts.

Maximum speed (mm/s)
* Varies depending on the stroke.

Stroke	1000	1100	1200	1300	1400	1500	1600	1700	1800	1900	2000	2100	2200	2300	2400	2500
A	1588	1688	1788	1888	1988	2088	2188	2288	2388	2488	2588	2688	2788	2888	2988	3088
B	1558	1658	1758	1858	1958	2058	2158	2258	2358	2458	2558	2658	2758	2858	2958	3058
C	1000	1100	1200	1300	1400	1500	1600	1700	1800	1900	2000	2100	2200	2300	2400	2500
D	4	5	5	6	6	7	7	8	8	9	9	10	10	11	11	12
E	20	22	22	24	24	26	26	28	28	30	30	32	32	34	34	36
F	173.5	73.5	173.5	73.5	173.5	73.5	173.5	73.5	173.5	73.5	173.5	73.5	173.5	73.5	173.5	73.5
G	390	420	440	470	490	520	530	570	590	620	640	670	690	720	730	770
H	390	450	440	500	490	550	540	590	590	650	640	700	690	750	740	790
Weight (kg)	31.7	33.3	34.9	36.5	38.1	39.8	41.4	43.0	44.6	46.2	47.8	49.4	51.0	52.6	54.2	55.8
Lead 20	1000			950			830	740	650	590	540	490	440	410	370	340

Applicable Controller Specifications

Applicable controller	Maximum number of controlled axes	Compatible encoder type	Operating method	Supply voltage	Maximum Output
X-SEL-P/Q	6 axes	Absolute /incremental	Program/ Positioner	1-phase 230VAC/ 3-phase 200VAC	1600W/ 2400W
X-SEL-KE/KT	4 axes			1600W	
S-SEL	2 axes			800W	
S-/E-Con	1 axis			750W	



(Note 1) When the stroke increases, the maximum speed drops in order to prevent the ball screw from reaching a dangerous speed. (Refer to the above table for the maximum speed at each stroke.)
(Note 2) Refer to page 22 for the relationship of acceleration and load capacity.
(Notes 3, 4, 5) The figures in [] apply to the ISPDACR Series.
(Note 6) The maximum cable length is 30 m. Specify a desired length in meters. (Example: X08 = 8 m)

ISDACR-LX-400

Single-Axis Robot: Large Cleanroom Mid-support Type
Actuator Width 155mm, 400W, Straight Shape

ISPDACR-LX-400

Single-Axis Robot: Large Cleanroom Mid-support Type
Actuator Width 155mm, 400W, Straight Shape, High-Precision Specification

Type	Large (155 mm wide) Mid-support Type	Stroke	1000~2500mm	Load capacity	80kg (horizontal)
------	---	--------	-------------	---------------	-------------------

Model specification items Series Type Encoder type Motor output Lead Stroke Applicable controller Cable length Options

(Example) ISDACR-LX - A - 400 - 20 - 2500 - T1 - S - B



* Refer to page 1 for the details of model specification items.

Model/Specifications

Model	Encoder Type	Motor output (W)	Lead (mm)	Stroke 100mm increments (mm)	Speed (mm/s) (Note 1)	Load capacity (Note 2)				Rated thrust (N)	Positioning repeatability (mm) (Note 3)	Suction rate (Nℓ/min)
						Horizontal (kg)		Vertical (kg)				
						Rated acceleration	Maximum acceleration	Rated acceleration	Maximum acceleration			
ISDACR [ISPDACR]-LX- <u>1</u> -400- <u>2</u> - <u>3</u> - <u>4</u> - <u>5</u>	Absolute Incremental	400	20	1000 ~ 2500	1 ~ 1000	80	Horizontal only		340.1	0.02 [0.01]	90	

* In the above model names, ① indicates the encoder type, ② the stroke, ③ the applicable controller, ④ the cable length, and ⑤ the applicable options.

Options

Name	Code	Page	Remarks
AQ seal	AQ	→P22	
Brake	B	→P22	
Reversed home specification	NM	→P22	
Guide with ball-retaining mechanism	RT	→P22	
Suction duct joint on opposite side	VR	→Back	
Metal cable joint connector	EU	→Back, P2	

Common Specifications

Drive system (Note 4)	Ball screw ϕ 20mm, rolled C10 [equivalent to rolled C5]
Backlash (Note 5)	0.05mm or less [0.02mm or less]
Guide	Integrated with base
Grease	Low dust raising grease (for both ball screw and guide)
Allowable load moment	Ma: 104.9Nm, Mb: 149.9Nm, Mc: 248.9Nm
Overhang load length	Ma/Mb/Mc directions: 750mm or less
Base	Material: Aluminum with white alumite treatment
Applicable controller	T1: XSEL-KE/KT, E-Con; T2: XSEL-P/Q, SSEL, S-Con
Cable length (Note 6)	S: 3m, M: 5m, X□□: Length specification
Cleanliness level	Conforming to ISO Class 4 (0.1 μ m)
Suction duct joint	Quick duct joint with applicable outer tube diameter of ϕ 12

Dimensions

* Note that changing the home direction will require the actuator to be returned to IAI for adjustment.

* Due to their structure, the mid-support type cannot be positioned horizontally on their side, or in vertical direction.

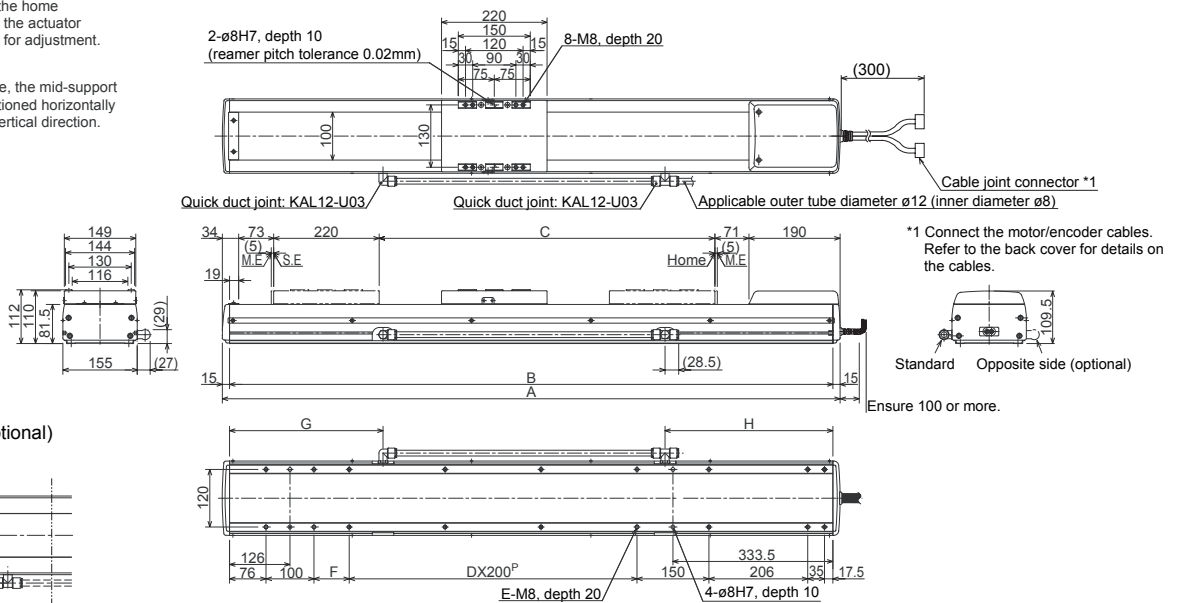

Brake type (optional)

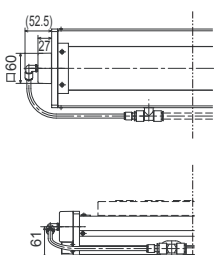

* Actuators with the brake are heavier by 1.1 kg than their non-brake counterparts.

Maximum speed (mm/s)
* Varies depending on the stroke.

Stroke	1000	1100	1200	1300	1400	1500	1600	1700	1800	1900	2000	2100	2200	2300	2400	2500
A	1588	1688	1788	1888	1988	2088	2188	2288	2388	2488	2588	2688	2788	2888	2988	3088
B	1558	1658	1758	1858	1958	2058	2158	2258	2358	2458	2558	2658	2758	2858	2958	3058
C	1000	1100	1200	1300	1400	1500	1600	1700	1800	1900	2000	2100	2200	2300	2400	2500
D	4	5	5	6	6	7	7	8	8	9	9	10	10	11	11	12
E	20	22	22	24	24	26	26	28	28	30	30	32	32	34	34	36
F	173.5	73.5	173.5	73.5	173.5	73.5	173.5	73.5	173.5	73.5	173.5	73.5	173.5	73.5	173.5	73.5
G	390	420	440	470	490	520	530	570	590	620	640	670	690	720	730	770
H	390	450	440	500	490	550	540	590	590	650	640	700	690	750	740	790
Weight (kg)	32.1	33.7	35.3	36.9	38.5	40.1	41.7	43.4	45.0	46.6	48.2	49.8	51.4	53.0	54.6	56.2
Lead 20	1000			950		830	740	650	590	540	490	440	410	370	340	

Applicable Controller Specifications

Applicable controller	Maximum number of controlled axes	Compatible encoder type	Operating method	Supply voltage	Maximum Output
X-SEL-P/Q	6 axes	Absolute /incremental	Program/ Positioner	1-phase 230VAC/ 3-phase 200VAC	1600W/ 2400W
X-SEL-KE/KT	4 axes			1-phase 100VAC/ 230VAC	1600W
S-SEL	2 axes				800W
S-E-Con	1 axis				750W



(Note 1) When the stroke increases, the maximum speed drops in order to prevent the ball screw from reaching a dangerous speed. (Refer to the above table for the maximum speed at each stroke.)

(Note 2) Refer to page 22 for the relationship of acceleration and load capacity.

(Notes 3, 4, 5) The figures in [] apply to the ISPDACR Series.

(Note 6) The maximum cable length is 30 m. Specify a desired length in meters. (Example: X08 = 8 m)

ISDACR-W-600 Single-Axis Robot: Super Large Cleanroom Type, Actuator Width 198mm, 600W, Straight Shape

ISPDACR-W-600 Single-Axis Robot: Super Large Cleanroom Type, Actuator Width 198mm, 600W, Straight Shape, High-Precision Specification

Type / Super large (198-mm wide) Stroke / 100-1300mm Load capacity / 150kg (horizontal)/60kg (vertical)

Model specification items Series Type Encoder type Motor output Lead Stroke Applicable controller Cable length Options

(Example) ISDACR-W- A - 600 - 40 - 1300 - T1 - S - L - NM

* Refer to page 1 for the details of model specification items.



Models/Specifications

Model	Encoder Type	Motor output (W)	Lead (mm)	Stroke 100mm increments (mm)	Speed (Note 1) (mm/s)	Load capacity (Note2)				Rated thrust (N)	Suction rate (Nl/min)
						Horizontal (kg)		Vertical (kg)			
						Rated acceleration	Maximum acceleration	Rated acceleration	Maximum acceleration		
ISDACR [ISPDACR]-W- 1 - 600-40- 2 - 3 - 4 - L- 5	Absolute Incremental	600	40	100 ~ 1300	1 ~ 2000	60	18	14	5	255	120
ISDACR [ISPDACR]-W- 1 - 600-20- 2 - 3 - 4 - L- 5			20		1 ~ 1000	120	36	29	15	510	60
ISDACR [ISPDACR]-W- 1 - 600-10- 2 - 3 - 4 - L- 5			10		1 ~ 500	150	75	60	40	1020	40

* In the above model names, 1 indicates the encoder type, 2 the stroke, 3 the applicable controller, 4 the cable length, and 5 the applicable options.

Options

Name	Code	Page	Name	Code	Page
AQ seal	AQ	→P22	Master-axis designation	LM	→Back
Brake	B	→P22	Reversed home specification	NM	→P22
Creep sensor	C	→Back	Slave-axis designation	S	→Back
Home limit switch	L	→Back	Suction duct joint on opposite side	VR	→Back
Metal cable joint connector	EU	→Back,P2			

* The W type comes standard with home limit switch (code: L).

Common Specifications

* The specifications of the ISPDACR are shown in [].

Positioning repeatability	±0.02mm [±0.01mm]
Drive system	Ball screw ø20mm, equivalent to rolled C10 [equivalent to C5]
Backlash	0.05mm or less [0.02mm or less]
Guide	Integrated with base
Grease	Low dust-raising grease (for both ball screw and guide)
Allowable load moment	Ma: 112.7N·m, Mb: 161.7N·m, Mc: 356.7N·m
Overhang load length	Ma/Mb/Mc directions: 800mm or less
Base	Material: Aluminum with white alumite treatment
Applicable controller	T1: XSEL-KE/KT, E-Con; T2: XSEL-P/Q, SSEL, S-Con
Cable length (Note 3)	N: No cable, S: 3m, M: 5m, X []: Length specification
Cleanliness class	Conforming to ISO class 4 (0.1μm)
Suction duct joint	Quick duct joint with applicable tube outer diameter of ø12

Dimensions

* Those equipped with an optional brake have the same external dimensions, but the weight increases by 0.5 kg.

* To change the home direction, the actuator must be returned to IAI for adjustment.

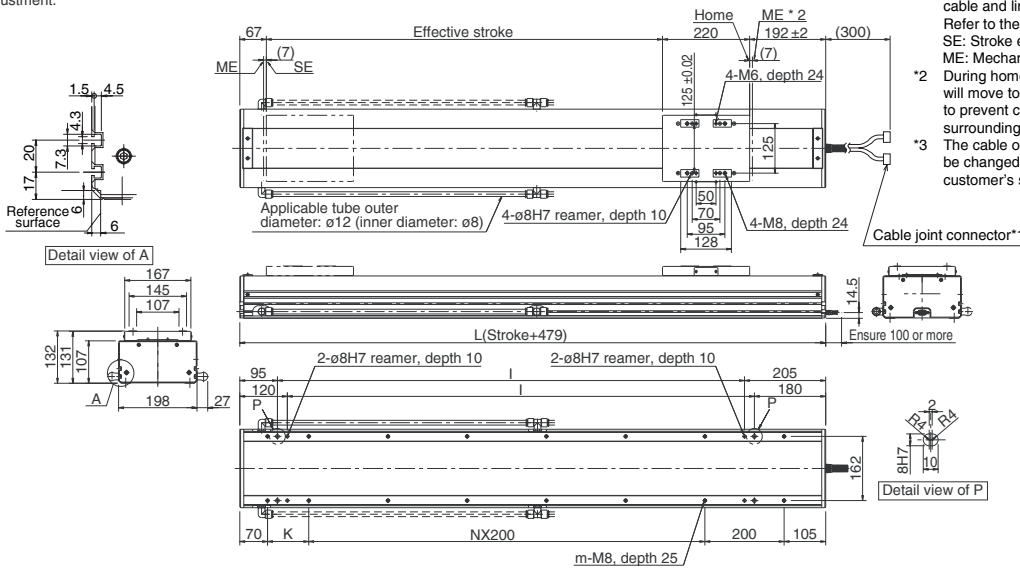

- *1 Connect the motor cable, encoder cable and limit switch cables here. Refer to the back cover for the details of each cable. SE: Stroke end ME: Mechanical end
- *2 During home return, the slider will move to the ME, so be careful to prevent contact with surrounding parts.
- *3 The cable outlet direction can be changed to right or left at the customer's site.

Dimensions, Weight and Maximum Speed by Stroke

Stroke	100	200	300	400	500	600	700	800	900	1000	1100	1200	1300
L	579	679	779	879	979	1079	1179	1279	1379	1479	1579	1679	1779
I	279	379	479	579	679	779	879	979	1079	1179	1279	1379	1479
K	204	104	204	104	204	104	204	104	204	104	204	104	204
N	0	1	1	2	2	3	3	4	4	5	5	6	6
m	6	8	8	10	10	12	12	14	14	16	16	18	18
Weight (kg)	19.4	21.5	23.5	25.5	27.6	29.6	31.6	33.7	35.7	37.7	39.8	41.8	43.8
Maximum speed (mm/s)	Lead 40		2000				1965		1605	1335	1130	970	840
	Lead 20		1000				980		800	665	565	485	420
	Lead 10		500				490		400	330	280	240	210

* Varies depending on the stroke.

Applicable Controller Specifications

Applicable controller	Maximum number of controlled axes	Compatible encoder type	Operating method	Supply voltage	Maximum Output
X-SEL-P/Q	6 axes	Absolute /incremental	Program/ Positioner	1-phase 230VAC/ 3-phase 200VAC	1600W/ 2400W
X-SEL-KE/KT	4 axes				1600W
S-SEL	2 axes		1-phase 100VAC/ 230VAC	800W	
S-E-Con	1 axis		Positioner/ Pulse train	750W	

* The W type comes standard with home limit switch, so use it with a controller of the limit switch specification.

(Note 1) When the stroke increases, the maximum speed drops in order to prevent the ball screw from reaching a dangerous speed. (Refer to the above table for the maximum speed at each stroke.)

(Note 2) Refer to page 22 for the load capacity.

(Note 3) The maximum cable length is 30 m. Specify a desired length in meters. (Example: X08 = 8 m)

ISDACR-W-750

Single-Axis Robot: Super Large Cleanroom Type, Actuator Width 198mm, 750W, Straight Shape

ISPDACR-W-750

Single-Axis Robot: Super Large Cleanroom Type, Actuator Width 198mm, 750W, Straight Shape, High-Precision Specification

Type / Super large (198-mm wide) Stroke / 100-1300mm Load capacity / 120kg (horizontal)/29kg (vertical)

Model specification items Series Type Encoder type Motor output Lead Stroke Applicable controller Cable length Options
 (Example) ISDACR-W- A - 750 - 50 -1300- T1 - S -L-NM

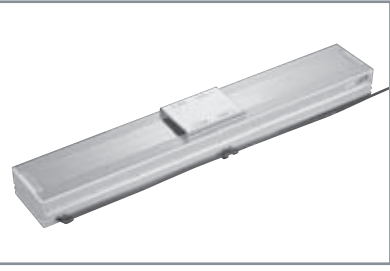

* Refer to page 1 for the details of model specification items.

Models/Specifications

Model	Encoder Type	Motor output (W)	Lead (mm)	Stroke 100mm increments (mm)	Speed (Note 1) (mm/s)	Load capacity (Note 2)				Rated thrust (N)	Suction rate (Nl/min)
						Horizontal (kg)		Vertical (kg)			
						Rated	Maximum acceleration	Rated	Maximum acceleration		
ISDACR [ISPDACR]-W- 1 -750-50- 2 - 3 - 4 -L- 5	Absolute	750	50	100 ~ 1300	1 ~ 2000	60	18	14	5	255	120
ISDACR [ISPDACR]-W- 1 -750-25- 2 - 3 - 4 -L- 5	Incremental		25		1 ~ 1250	120	36	29	15	510	60

* In the above model names, 1 indicates the encoder type, 2 the stroke, 3 the applicable controller, 4 the cable length, and 5 the applicable options.

Options

Name	Code	Page	Name	Code	Page
AQ seal	AQ	→P22	Master-axis designation	LM	→Back
Brake	B	→P22	Reversed home specification	NM	→P22
Creep sensor	C	→Back	Slave-axis designation	S	→Back
Home limit switch	L	→Back	Suction duct joint on opposite side	VR	→Back
Metal cable joint connector	EU	→Back,P2			

* The W type comes standard with home limit switch (code: L).

Common Specifications

* The specifications of the ISPDACR are shown in [].

Positioning repeatability	±0.02mm [±0.01mm]
Drive system	Ball screw ø20mm, equivalent to rolled C10 [equivalent to C5]
Backlash	0.05mm or less [0.02mm or less]
Guide	Integrated with base
Grease	Low dust-raising grease (for both ball screw and guide)
Allowable load moment	Ma: 112.7N·m, Mb: 161.7N·m, Mc: 356.7N·m
Overhang load length	Ma/Mb/Mc directions: 800mm or less
Base	Material: Aluminum with white alumite treatment
Applicable controller	T1: XSEL-KE/KT, E-Con; T2: XSEL-P/Q, SSEL, S-Con
Cable length (Note 3)	N: No cable, S: 3m, M: 5m, X []: Length specification
Cleanliness class	Conforming to ISO class 4 (0.1µm)
Suction duct joint	Quick duct joint with applicable tube outer diameter of ø12

Dimensions

* To change the home direction, the actuator must be returned to IAI for adjustment.
 * Those equipped with an optional brake have the same external dimensions, but the weight increases by 0.5 kg.

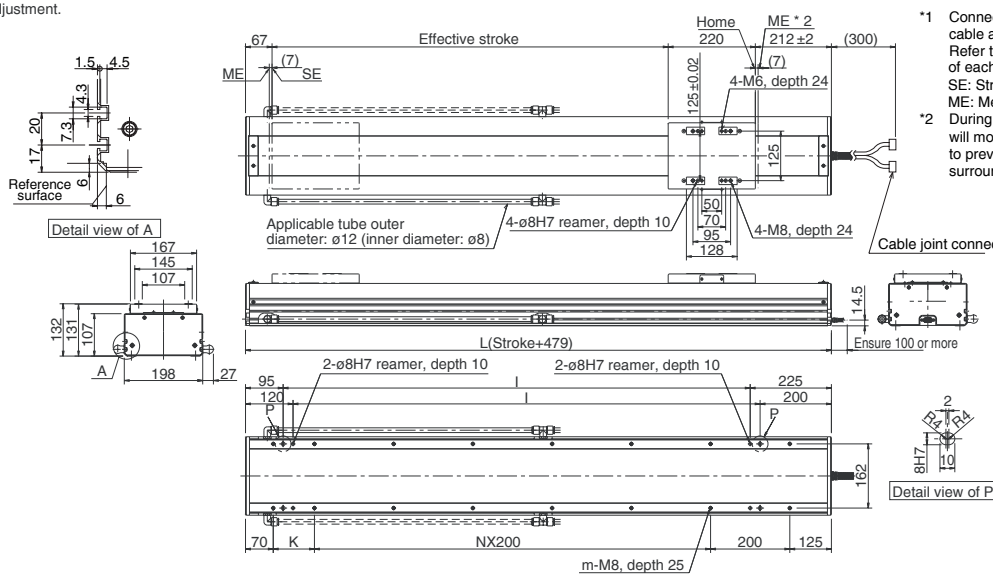

- *1 Connect the motor cable, encoder cable and limit switch cables here. Refer to the back cover for the details of each cable.
SE: Stroke end
ME: Mechanical end
- *2 During home return, the slider will move to the ME, so be careful to prevent contact with surrounding parts.

Dimensions, Weight and Maximum Speed by Stroke

Stroke	100	200	300	400	500	600	700	800	900	1000	1100	1200	1300
L	599	699	799	899	999	1099	1199	1299	1399	1499	1599	1699	1799
I	279	379	479	579	679	779	879	979	1079	1179	1279	1379	1479
K	204	104	204	104	204	104	204	104	204	104	204	104	204
N	0	1	1	2	2	3	3	4	4	5	5	6	6
m	6	8	8	10	10	12	12	14	14	16	16	18	18
Weight (kg)	23.4	25.5	27.5	29.5	31.6	33.6	35.6	37.7	39.7	41.7	43.8	45.8	47.8
Maximum speed (mm/s) * Varies depending on the stroke.	Lead 50		2000								1780	1525	1320
	Lead 25		1250								1050	890	760

Applicable Controller Specifications

Applicable controller	Maximum number of controlled axes	Compatible encoder type	Operating method	Supply voltage	Maximum Output
X-SEL-P/Q	6 axes	Absolute /incremental	Program/ Positioner	1-phase 230VAC/ 3-phase 200VAC	1600W/ 2400W
X-SEL-KE/KT	4 axes				1600W
S-SEL	2 axes		1-phase 100VAC/ 230VAC	800W	
S-E-Con	1 axis		Positioner/ Pulse train	750W	

Caution

(Note 1) When the stroke increases, the maximum speed drops in order to prevent the ball screw from reaching a dangerous speed. (Refer to the above table for the maximum speed at each stroke.)
 (Note 2) Refer to page 22 for the load capacity.
 (Note 3) The maximum cable length is 30 m. Specify a desired length in meters. (Example: X08 = 8 m)

* The W type comes standard with home limit switch, so use it with a controller of the limit switch specification.

ISDACR-WX-600

Single-Axis Robot: Super Large Cleanroom Mid-Support Type, Actuator Width 198mm, 600W, Straight Shape

ISPDACR-WX-600

Single-Axis Robot: Super Large Cleanroom Mid-Support Type, Actuator Width 198mm, 600W, Straight Shape, High-Precision Specification

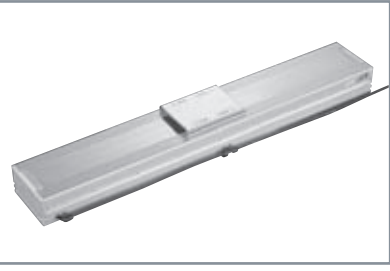

Type / Super large (198-mm wide) Stroke / 900-2500mm Load capacity / 120kg (horizontal)

Model specification items Series Type Encoder type Motor output Lead Stroke Applicable controller Cable length Options

(Example) ISDACR-WX- A - 600 - 40 - 2500 - T1 - S - B

* Refer to page 1 for the details of model specification items.

Models/Specifications

* Use the mid-support type at the rated acceleration or below.

Model	Encoder Type	Motor output (W)	Lead (mm)	Stroke 100mm increments (mm)	Speed (Note 1) (mm/s)	Load capacity (Note2)		Rated thrust (N)	Suction rate (Nl/min)
						Horizontal (kg)	Vertical (kg)		
						Rated acceleration	Maximum acceleration		
ISDACR [ISPDACR]-WX- ① - 600-40- ② - ③ - ④ - L- ⑤	Absolute	600	40	900 ~ 2500	1 ~ 2000	60	Horizontal only	255	120
ISDACR [ISPDACR]-WX- ① - 600-20- ② - ③ - ④ - L- ⑤	Incremental		20		1 ~ 1000	120			

* In the above model names, ① indicates the encoder type, ② the stroke, ③ the applicable controller, ④ the cable length, and ⑤ the applicable options.

Options

Name	Code	Page	Name	Code	Page
AQ seal	AQ	→P22	Master-axis designation	LM	→Back
Brake	B	→P22	Reversed home specification	NM	→P22
Creep sensor	C	→Back	Slave-axis designation	S	→Back
Home limit switch	L	→Back	Suction duct joint on opposite side	VR	→Back
Metal cable joint connector	EU	→Back,P2			

* The WX type comes standard with home limit switch (code: L).

Common Specifications

* The specifications of the ISPDACR are shown in [].

Positioning repeatability	±0.02mm [±0.01mm]
Drive system	Ball screw ø20mm, equivalent to rolled C10 [equivalent to C5]
Backlash	0.05mm or less [0.02mm or less]
Guide	Integrated with base
Grease	Low dust-raising grease (for both ball screw and guide)
Allowable load moment	Ma: 112.7N·m, Mb: 161.7N·m, Mc: 356.7N·m
Overhang load length	Ma/Mb/Mc directions: 800mm or less
Base	Material: Aluminum with white alumite treatment
Applicable controller	T1: XSEL-KE/KT, E-Con; T2: XSEL-P/Q, SSEL, S-Con
Cable length (Note 3)	N: No cable, S: 3m, M: 5m, X□□□: Length specification
Cleanliness class	Conforming to ISO class 4 (0.1µm)
Suction duct joint	Quick duct joint with applicable tube outer diameter of ø12

Dimensions

* Those equipped with an optional brake have the same external dimensions, but the weight increases by 0.5 kg.

* To change the home direction, the actuator must be returned to |A| for adjustment.

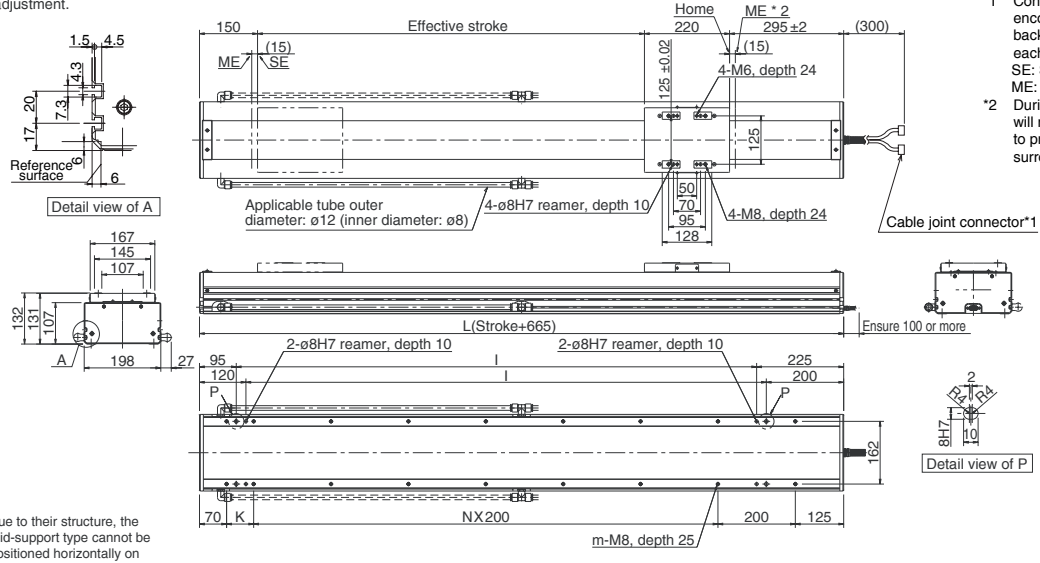

- *1 Connect the motor cable and encoder cable here. Refer to the back cover for the details of each cable.
SE: Stroke end
ME: Mechanical end
- *2 During home return, the slider will move to the ME, so be careful to prevent contact with surrounding parts.

* Due to their structure, the mid-support type cannot be positioned horizontally on their side, or in the vertical direction.

Dimensions, Weight and Maximum Speed by Stroke

Stroke	900	1000	1100	1200	1300	1400	1500	1600	1700	1800	1900	2000	2100	2200	2300	2400	2500
L	1565	1665	1765	1865	1965	2065	2165	2265	2365	2465	2565	2665	2765	2865	2965	3065	3165
I	1245	1345	1445	1545	1645	1745	1845	1945	2045	2145	2245	2345	2445	2545	2645	2745	2845
K	170	70	170	70	170	70	170	70	170	70	170	70	170	70	170	70	170
N	5	6	6	7	7	8	8	9	9	10	10	11	11	12	12	13	13
m	16	18	18	20	20	22	22	24	24	26	26	28	28	30	30	32	32
Weight (kg)	39.5	41.5	43.6	45.6	47.6	49.7	51.7	53.8	55.8	57.8	59.9	61.9	63.9	66.0	68.0	70.0	72.1
Maximum speed (mm/s) * Varies depending on the stroke.	Lead 40		2000		1965		1725	1530	1365	1225	1110	1005	915	840	770	710	655
	Lead 20		1000		980		860	765	680	610	555	500	455	420	385	355	325

Applicable Controller Specifications

Applicable controller	Maximum number of controlled axes	Compatible encoder type	Operating method	Supply voltage	Maximum Output
X-SEL-P/Q	6 axes	Absolute /incremental	Program/ Positioner	1-phase 230VAC/ 3-phase 200VAC	1600W/ 2400W
X-SEL-KE/KT	4 axes			1600W	
S-SEL	2 axes		1-phase 100VAC/ 230VAC	800W	
S-E-Con	1 axis		Positioner/ Pulse train	750W	

Caution

(Note 1) When the stroke increases, the maximum speed drops in order to prevent the ball screw from reaching a dangerous speed. (Refer to the above table for the maximum speed at each stroke.)

(Note 2) Refer to page 22 for the load capacity.

(Note 3) The maximum cable length is 30 m. Specify a desired length in meters. (Example: X08 = 8 m)

* The WX type comes standard with home limit switch, so use it with a controller of the limit switch specification.

ISDACR-WX-750

Single-Axis Robot: Super Large Cleanroom Mid-Support Type, Actuator Width 198mm, 750W, Straight Shape

ISPDACR-WX-750

Single-Axis Robot: Super Large Cleanroom Mid-Support Type, Actuator Width 198mm, 750W, Straight Shape, High-Precision Specification

Type / Super large (198-mm wide) Stroke / 900~2500mm Load capacity / 120kg (horizontal)



Model specification items Series Type Encoder type Motor output Lead Stroke Applicable controller Cable length Options
 (Example) ISDACR-WX- A - 750 - 50 -2500- T1 - S - B

* Refer to page 1 for the details of model specification items.

Models/Specifications

* Use the mid-support type at the rated acceleration or below.

Model	Encoder Type	Motor output (W)	Lead (mm)	Stroke 100mm increments (mm)	Speed (Note 1) (mm/s)	Load capacity (Note2)		Rated thrust (N)	Suction rate (Nl/min)
						Horizontal (kg)	Vertical (kg)		
						Rated acceleration	Maximum acceleration		
ISDACR [ISPDACR]-WX- ① -750-50- ② - ③ - ④ -L- ⑤	Absolute	750	50	900 ~ 2500	1 ~ 2000	60	Horizontal only	255	120
ISDACR [ISPDACR]-WX- ① -750-25- ② - ③ - ④ -L- ⑤	Incremental		25			120			

* In the above model names, ① indicates the encoder type, ② the stroke, ③ the applicable controller, ④ the cable length, and ⑤ the applicable options.

Options

Name	Code	Page	Name	Code	Page
AQ seal	AQ	→P22	Master-axis designation	LM	→Back
Brake	B	→P22	Reversed home specification	NM	→P22
Creep sensor	C	→Back	Slave-axis designation	S	→Back
Home limit switch	L	→Back	Suction duct joint on opposite side	VR	→Back
Metal cable joint connector	EU	→Back,P2			

* The WX type comes standard with home limit switch (code: L).

Common Specifications

* The specifications of the ISPDACR are shown in [].

Positioning repeatability	±0.02mm [±0.01mm]
Drive system	Ball screw ø20mm, equivalent to rolled C10 [equivalent to C5]
Backlash	0.05mm or less [0.02mm or less]
Guide	Integrated with base
Grease	Low dust-raising grease (for both ball screw and guide)
Allowable load moment	Ma: 112.7N·m, Mb: 161.7N·m, Mc: 356.7N·m
Overhang load length	Ma/Mb/Mc directions: 800mm or less
Base	Material: Aluminum with white alumite treatment
Applicable controller	T1: XSEL-KE/KT, E-Con; T2: XSEL-P/Q, SSEL, S-Con
Cable length (Note 3)	N: No cable, S: 3m, M: 5m, X□□□: Length specification
Cleanliness class	Conforming to ISO class 4 (0.1µm)
Suction duct joint	Quick duct joint with applicable tube outer diameter of ø12

Dimensions

* Those equipped with an optional brake have the same external dimensions.

* To change the home direction, the actuator must be returned to |A| for adjustment.

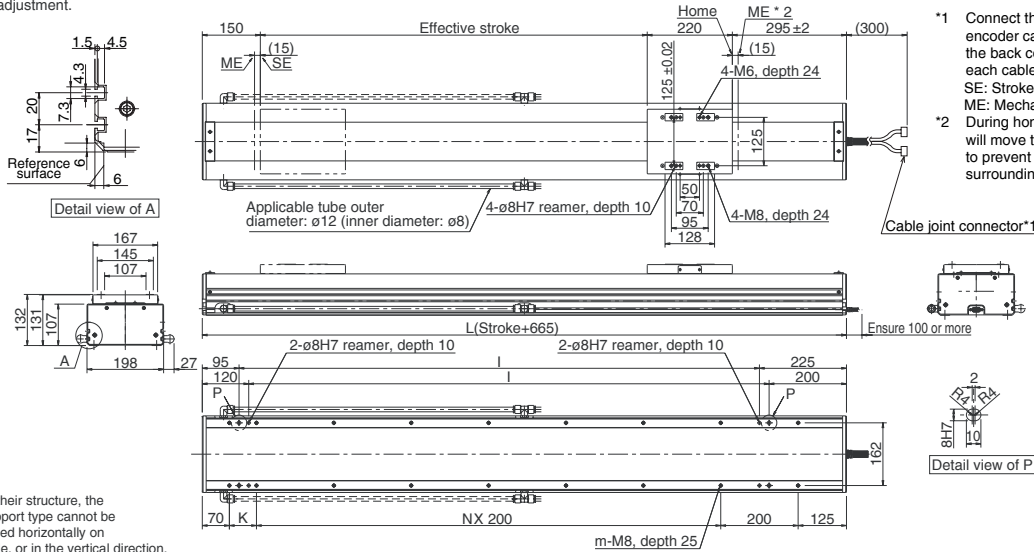

- 1 Connect the motor cable and encoder cable here. Refer to the back cover for the details of each cable.
SE: Stroke end
ME: Mechanical end
- 2 During home return, the slider will move to the ME, so be careful to prevent contact with surrounding parts.

* Due to their structure, the mid-support type cannot be positioned horizontally on their side, or in the vertical direction.

Dimensions, Weight and Maximum Speed by Stroke

Stroke	900	1000	1100	1200	1300	1400	1500	1600	1700	1800	1900	2000	2100	2200	2300	2400	2500	
L	1565	1665	1765	1865	1965	2065	2165	2265	2365	2465	2565	2665	2765	2865	2965	3065	3165	
I	1245	1345	1445	1545	1645	1745	1845	1945	2045	2145	2245	2345	2445	2545	2645	2745	2845	
K	170	70	170	70	170	70	170	70	170	70	170	70	170	70	170	70	170	
N	5	6	6	7	7	8	8	9	9	10	10	11	11	12	12	13	13	
m	16	18	18	20	20	22	22	24	24	26	26	28	28	30	30	32	32	
Weight (kg)	44.5	46.5	48.6	50.6	52.6	54.7	56.7	58.8	60.8	62.8	64.9	66.9	68.9	71.0	73.0	75.0	77.1	
Maximum speed (mm/s) * Varies depending on the stroke.	Lead 50	2000						1930	1740	1580	1440	1320	1210	1115	1035			
	Lead 25	1250						1200	1075	965	870	790	720	660	605	555	515	

Applicable Controller Specifications

Applicable controller	Maximum number of controlled axes	Compatible encoder type	Operating method	Supply voltage	Maximum Output
X-SEL-P/Q	6 axes	Absolute /incremental	Program/ Positioner	1-phase 230VAC/ 3-phase 200VAC	1600W/ 2400W
X-SEL-KE/KT	4 axes			1600W	
S-SEL	2 axes		1-phase 100VAC/ 230VAC	800W	
S-/E-Con	1 axis		Positioner/ Pulse train	750W	



(Note 1) When the stroke increases, the maximum speed drops in order to prevent the ball screw from reaching a dangerous speed. (Refer to the above table for the maximum speed at each stroke.)
 (Note 2) Refer to page 22 for the load capacity.
 (Note 3) The maximum cable length is 30 m. Specify a desired length in meters. (Example: X08 = 8 m)

* The WX type comes standard with home limit switch, so use it with a controller of the limit switch specification.

Horizontal Load Capacity by Acceleration Condition (Reference)

* The load capacities shown below are reference figures and not guaranteed. They should be used for reference purposes only.

Type	Motor output (W)	Lead (mm)	Maximum speed (mm/sec)	Rated acceleration (G)	Load capacity at rated acceleration (kg)	Maximum acceleration (G)	Load capacity by acceleration (kg)									
							0.3G	0.4G	0.5G	0.6G	0.7G	0.8G	0.9G	1.0G		
S	60	16	800	0.3	Horizontal	12	1.0	12	9	7	6	5	4.5	4	3.5	
					Vertical	3	0.7	3	2.5	2.3	2.1	2	-	-	-	
		8	400	0.3	Horizontal	25	0.6	25	18.5	15	12	-	-	-	-	
					Vertical	6	0.5	6	5.5	5	-	-	-	-		
		4	200	0.15	Horizontal	50	0.5	50	37.5	30	-	-	-	-	-	
					Vertical	14	0.3	12	-	-	-	-	-	-		
M	100	20	1000	0.3	Horizontal	20	1.0	20	15	12	10	8.5	7.5	6.5	6	
					Vertical	3.5	0.8	3.5	3.2	2.9	2.7	2.4	2	-	-	
		10	500	0.3	Horizontal	40	0.6	40	30	24	20	-	-	-	-	
					Vertical	9	0.5	9	7.6	7	-	-	-	-		
		5	250	0.15	Horizontal	80	0.5	80	60	45	-	-	-	-	-	
					Vertical	19	0.3	15	-	-	-	-	-	-		
	200	20	1000	0.3	Horizontal	40	1.0	40	30	24	20	17	15	13.5	12	
					Vertical	9	0.8	9	7.6	7	6.5	6	5	-	-	
		10	500	0.3	Horizontal	80	0.6	80	60	48.5	40	-	-	-	-	
					Vertical	19	0.5	19	16.3	15	-	-	-	-		
		200	20	1000	0.3	Horizontal	40	0.3	40	-	-	-	-	-	-	
						Vertical	9	0.8	9	6.6	6	5.5	5	4	-	-
L	200	20	1000	0.3	Horizontal	40	1.0	40	30	24	20	17	15	13.5	12	
					Vertical	9	0.8	9	6.6	6	5.5	5	4	-	-	
		10	500	0.3	Horizontal	80	0.6	80	60	48.5	40	-	-	-	-	
	Vertical				19	0.5	19	15.3	14	-	-	-	-			
	400	20	1000	0.3	Horizontal	80	1.0	80	60	48.5	40.5	34.5	30	27	24	
					Vertical	19	0.8	19	15.3	14.1	13.1	12.2	10	-	-	
200		20	1000	0.3	Horizontal	40	0.3	40	-	-	-	-	-	-		
	Vertical				9	0.8	9	6.6	6	5.5	5	4	-	-		
LX	200	20	1000	0.3	Horizontal	40	0.3	40	-	-	-	-	-	-		
					Vertical	9	0.8	9	6.6	6	5.5	5	4	-	-	
	400	20	1000	0.3	Horizontal	80	0.3	80	-	-	-	-	-	-		
					Vertical	19	0.5	19	15.3	14	-	-	-	-		
	W	600	40	2000	0.3	Horizontal	60	1.0	60	45	36	30	26	22	20	18
						Vertical	14	1.0	10	9	8.1	7.4	6.7	6.1	5.6	5
20			1000	0.3	Horizontal	120	1.0	120	91	72	60	52	45	40	36	
					Vertical	29	0.8	24	22	20.3	18.8	17.4	15	-	-	
10			500	0.3	Horizontal	150	0.6	150	112	90	75	-	-	-	-	
					Vertical	60	0.5	52	48	40	-	-	-	-		
750		50	2000	0.3	Horizontal	60	1.0	60	45	36	30	25	22	20	18	
					Vertical	14	1.0	10	9	8.1	7.4	6.7	6.1	5.6	5	
		25	1250	0.3	Horizontal	120	1.0	120	91	72	60	52	45	40	36	
					Vertical	29	0.8	24	22	20.3	18.8	17.4	15	-	-	
		WX	600	40	2000	0.3	Horizontal	60	0.3	60	-	-	-	-	-	-
							Vertical	120	0.3	120	-	-	-	-	-	-
750	50		2000	0.3	Horizontal	60	0.3	60	-	-	-	-	-	-		
					Vertical	120	0.3	120	-	-	-	-	-	-		

• Even if the actual acceleration is below the rated acceleration, the load capacity will not increase beyond the level corresponding to the rated acceleration.

Options

AQ Seal

Code AQ

The AQ seal is a lubrication unit that uses lubricating material made of resin-solidified lubricating oil. The porous material impregnated with a large amount of lubricating oil slowly releases oil from its surface via capillary effect. The guide and ball screw surfaces (steel-ball rolling surface) are constantly lubricated as AQ seals are pressed against these surfaces. When used with grease, AQ seals enable maintenance-free operation for a long period.

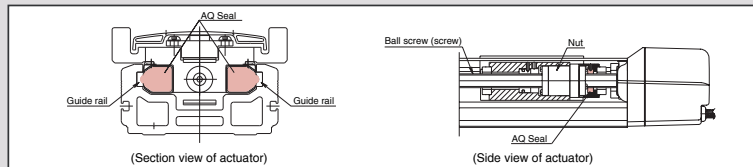

Brake

Code B

A retention mechanism that prevents the slider from falling and damaging the load when the power or servo is turned off in a vertical actuator application.

Anti-electrostatic Specification

Code ESD

This is the anti-electrostatic specification. The structural parts of the actuator are given electroless nickel-plating to add conductivity, thereby preventing the actuator from being charged with electricity. (Note: Due to plating, the maximum stroke is limited to 1000 mm on the ESD type.)

Reversed Home Specification

Code NM

The standard home direction is on the motor side. To change the home direction, the encoder must be adjusted. Should you require the reverse homing specification, please specify it in your order.

Guide with Ball-retaining Mechanism

Code RT

A spacer (retainer) is inserted between adjacent guide balls (steel balls) to achieve reduced noise and longer life. The spacers eliminate annoying metallic sounds generated by the balls contact with each other. These spacers also reduce the wear of balls caused by mutual friction, consequently extending the service life of the guide. The balls move smoothly without contacting each other, which improves slider mobility.

Creep Sensor

Code C

This sensor is used to perform high-speed home return. During home return, the slider normally contacts the stopper at the motor-side stroke end and then reverses its direction. For this reason, the homing speed is limited to 10 to 20 mm/s and it therefore takes time to complete home return when the stroke is long. This proximity sensor is used to shorten the time by allowing the slider to return at high speed until immediately before the home and then reduce its speed to the normal homing speed. Since this sensor is built into the actuator, the actuator dimensions remain the same.

Home Limit Switch

Code L

Single-axis robots normally perform home return based on the "contact method" whereby the slider contacts the stopper and then reverses its direction, after which phase Z is detected and the corresponding position is set as the home. When option L (home limit switches) is specified, home return is performed with the slider reversing not upon contact, but upon detection by a proximity sensor. Specifying option L adds the three proximity sensors of HOME (for home detection), +OT (for overtravel detection on motor side) and -OT (for overtravel detection on counter-motor side) to the actuator. (The HOME and -OT sensors are provided as an integrated twin sensor.) Super-large types that generate high thrust come standard with option L for safety reasons. The limit switch is also built into the actuator, just like the creep sensor.

Master-Axis Designation

Code LM

"Synchronized operation" is one of the functions provided by the X-SEL controller. This function allows two actuator axes to be operated simultaneously, with one axis functioning as the master (code: M) and the other as the slave (code: S). By causing the slave to follow the master via ultra high-speed control, the two axes operate virtually simultaneously. The two synchronized actuator axes must be of the exact same specifications (type, lead, motor output and stroke). When synchronized operation is to be performed, the master axis must have limit switch. Accordingly, add LM (master-axis specification with limit switch) to the model of the master axis and S (slave-axis specification) to the model of the slave axis.

Slave-Axis Designation

Code S

Specify this code for the slave axis in synchronized operation (refer to the explanation of "LM").

Suction Duct Joint on Opposite Side

Code VR

The standard position of the air suction joint is on the left side when viewed from the motor, and this option is to change the position to the opposite side (right side).

Metal Cablejoint Connector

Code EU

Select this option for a motor/encoder cable with metal cable plugs (see figure down right). Without this option plastic plugs are default. By this option cable lengths to 5 m are without surcharge, too.

Motor Cable/ Encoder Cable

In , enter a desired cable length (L) up to 30 m. (Example: 080 = 8 m)

Motor Cable (XSEL-KE/KT/P/Q, SSEL, ECON, SCON)

[Model: CB-X-MA /CB-XEU-MA] (*"EU": Cable option, see fig. down right)

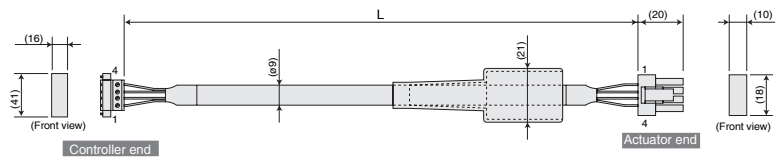

Motor Cable suitable for all Controllers: *

[XSEL]

[SSEL]

[ECON/SCON]



Encoder Cable (XSEL-KE/KT, ECON)

[Model: CB-X-PA /CB-XEU-PA] (*"EU": Cable option, see fig. down right)

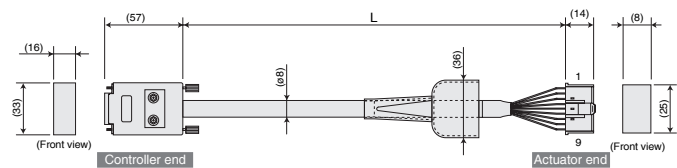

Limit Switch Cable (XSEL-KE/KT, ECON)

[Model: CB-X-LC /CB-XEU-LC] (*"EU": Cable option, see fig. down right)

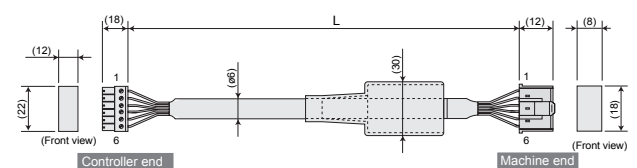

Encoder Cable (XSEL-P/Q, SSEL, SCON)

[Model: CB-X1-PA /CB-X1EU-PA] (*"EU": Cable option, see fig. right)
 [Model: CB-X1-PLA /CB-X1EU-PLA] (*"L": with integrated limit switch end)

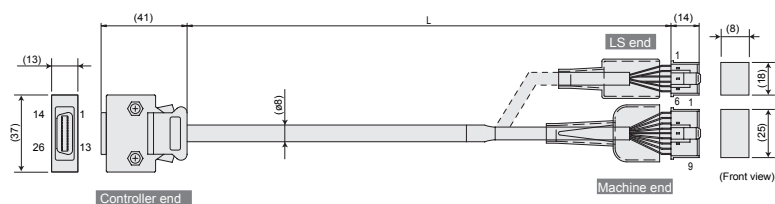

* A controller of program (S-/X-SEL), positioner or pulse-train (S-/E-CON) input type can be selected in accordance with the control method suitable for your application. Refer to a separate catalog for the details of each controller.