



# ERC3 Gateway Unit

## First Step Guide First Edition

Thank you for purchasing our product.  
 Make sure to read the Safety Guide and detailed Instruction Manual (CD/DVD) included with the product in addition to this First Step Guide to ensure correct use.  
 This Instruction Manual is original.

**Warning** : Operation of this equipment requires detailed installation and operation instructions which are provided on the CD/DVD Manual included in the box this device was packaged in. It should be retained with this device at all times.  
 A hardcopy of the Manual can be requested by contacting your nearest IAI Sales Office listed at the back cover of the Instruction Manual or on the First Step Guide.

- Using or copying all or part of this Instruction Manual without permission is prohibited.
- The company names, names of products and trademarks of each company shown in the sentences are registered trademarks.
- DeviceNet and CompoNet are a registered mark of ODVA.
- CC-Link is a registered trademark of Mitsubishi Electric Corporation.
- PROFIBUS is a registered trademark of PROFIBUS Association.
- MECHATROLINK is a registered trademark of MECHATROLINK Members Association.
- EtherCAT® is a registered mark of Beckoff Automation GmbH.
- EtherNet/IP is a trademark used under the license of ODVA.

### Product Check

This product is comprised of the following parts if it is of standard configuration.  
 If you find any fault in the contained model or any missing parts, contact us or our distributor.

No.	Part Name	Model	Remarks
1	Gateway Unit Main Body	Refer to "How to read the model plate", "How to read the model No."	
Accessories			
2	Power Connector	FMCD1.5/8-ST-3.5 (Supplier : PHOENIX CONTACT)	<ul style="list-style-type: none"> <li>• Emergency Stop Recommended cable size 0.5mm<sup>2</sup> (AWG20)</li> <li>• Power Supply Recommended cable size 1.25 to 0.5mm<sup>2</sup> (AWG16 to 20)</li> </ul>
3	CC-Link Connector (For CC-Link Type)	MSTB2.5/5-STF-5.08 AU (Supplier : PHOENIX CONTACT)	Terminal Resistance (130Ω/1/2W, 110Ω/1/2W) enclosed one unit each
4	DeviceNet Connector (For DeviceNet Type)	SMSTB2.5/5-ST-5.08AU (Supplier : PHOENIX CONTACT)	Prepare a terminal resistor separately if this controller is to be allocated at the terminal.
5	Absolute Battery Box (Option)	EGW-ABB (Battery AB-7)	For Simple Absolute Type
6	First Step Guide		
7	Instruction Manual (DVD)		
8	Safety Guide		

#### 2. Teaching Tool (Please purchase separately)

A teaching tool such as PC software is necessary when performing the setup for position setting, parameter setting, etc. that can only be done on the teaching tool.  
 Please prepare either of the following teaching tools.

No.	Part Name	Model
1	PC Software (Includes RS232C Exchange Adapter + Peripheral Communication Cable)	RCM-101-MW
2	PC Software (Includes USB Exchange Adapter + USB Cable + Peripheral Communication Cable)	RCM-101-USB
3	Teaching Pendant (Touch Panel Teaching)	CON-PTA
4	Teaching Pendant (Touch Panel Teaching with deadman switch)	CON-PDA
5	Teaching Pendant (Touch Panel Teaching with deadman switch + TP Adapter (RCB-LB-TG))	CON-PGA

#### 3. Instruction manuals related to this product, which are contained in the instruction manual (DVD).

No.	Name	Manual No.
1	ERC3 Gateway Unit Instruction Manual	ME0302
2	ERC3 Actuator with Integrated Controller Instruction Manual	ME0297
3	PC Software RCM-101-MW/RCM-101-USB Instruction Manual	ME0155
4	Touch Panel Teaching CON-PTA/PDA/PGA Instruction Manual	ME0295

#### 4. How to read the model plate

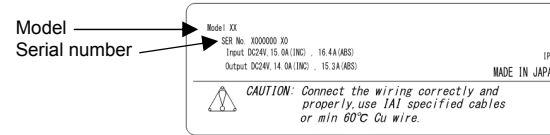

#### 5. How to read controller model code

##### • Gateway unit model

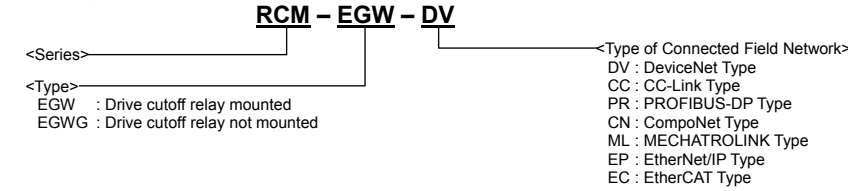

##### • Battery box model

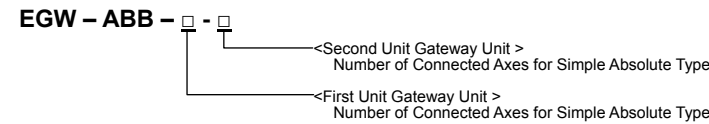

### Basic Specifications

List of Specifications		
Number of Controlled Axes		4 axes MAX.
Control/Motor Power Supply Voltage		24V DC ± 10%
Control Power Capacity		MAX. 1A
Load Current (Per axis)	High output setting valid (Note 1)	Rated 3.5A/MAX. 4.2A
	High output setting invalid (Note 1)	Rated 1.2A/MAX. 2.0A
Capacity of Brake Release Power Source (Per axis)		MAX. 0.15A
Control Power Capacity for Simple Absolute Unit		MAX. 1.4A
Heat Generation	High output setting valid (Note 1)	2.5W
	High output setting invalid (Note 1)	1.9W
In-Rush Current (Note 2)		MAX. 60A
Transient Power Cutoff Durability		20ms
Motor Control System		Refer to Instruction Manual for the actuator with integrated ERC3 controller
Applicable Encoder		
Cable Length Between Actuator and Gateway		MAX. 10m (Use the dedicated cable.)
Serial Communication Interface (SIO Port: Only for teaching)		RS485 1CH (based on Modbus Protocol) Speed 9.6 to 230.4kbps
External Interface		DeviceNet, CC-Link, PROFIBUS-DP, CompoNet, MECHATROLINK-II/I, EtherNet/IP, EtherCAT
Data Setting and Input		PC Software, Touch Panel Teaching, Gateway Parameter Create Tool
Data Retention Memory		Position data and parameters saved in the non-volatile memory of actuator via Gateway Unit (There is no limitation in number of writing)
Number of Positioning Points		MAX. 512 points (There is no limit for simple direct and direct indication modes) (Note) The number of positioning points differs depending on the operation pattern select by the parameter setting.
LED Display (Mounted on Front Panel)		1) Gateway status LEDs 6 points 2) Each axis status LEDs 6 points
Electromagnetic Brake Compulsory Release		Can be released with the brake compulsory release switch installed in the front panel for each axis
Protective functions		Overcurrent Protection
Protection Function against Electric Shock		Class 1 basic insulation
Insulation Resistance		500V DC 10MΩ
Cooling Method		Natural air-cooling
External Dimensions		35W × 140H × 105D
Weight		Approx. 220g (DeviceNet Type, CC-Link Type, PROFIBUS Type, CompoNet Type, EtherNet/IP Type)
		Approx. 230g (MECHATROLINK Type) Approx. 240g (EtherCAT Type)
Environment	Ambient Air Temperature	0 to 40°C
	Ambient Humidity	85%RH or less (non-condensing)
	Ambient Environment	[Refer to Installation Environment]
	Ambient Storage Temperature	-20 to 70°C * 0 to 40°C for absolute battery
	Ambient storage humidity	85%RH or less (non-condensing)
	Usable Altitude	1000m or lower above sea level
	Vibration Durability	Frequency 10 to 57Hz/ Swing width : 0.075mm Frequency 57 to 150Hz/ Acceleration : 9.8m/s <sup>2</sup> XYZ Each direction Sweep time: 10 min. Number of sweep: 10 times
Shock Resistance	150mm/s <sup>2</sup> 11ms Semi-sine wave pulse XYZ Each direction 3 times	
Protection Class		IP20

Note 1 Refer to the separate booklet Controller Integrated Actuator for the details of the connected actuator (ERC3).

Note 2 Rush current passes for about 50μs after the power is injected.

#### <Calculation of 24V DC Power Capacity>

For the calculation of 24V DC power capacity, figure out the numbers for (1) to (5) below, and then follow Step (6).

- (1) Control Power Current Consumption : 1A .....
- (2) Current Consumption of Motor Power Supply:  
Sum total of load current + (Number of actuator axes equipped with brake × 0.15A) .....
- (3) For Simple Absolute Type : 0.2A + (0.3A × Number of axes) .....
- (4) Current Consumption at Excitation Phase Detection:  
Add the inrush current for all connected axes .....
- (5) In-Rush Current : 60A .....
- (6) Selection of Power Supply:

Usually, the rated current is to be approximately 1.3 times higher than 1) + 2) + 3) above considering approximately 30% of margin to the load current. However, considering the current of 4) to 5), even though it is a short time, select a power supply with "peak load corresponding" type or that with enough capacity. For the current of 4) to 5), it can be avoided from the current consumption occurred at the same time by the timing for the emergency stop release (motor power-on) and servo-on being changed. In the case that the capacity margin is not sufficient, voltage might be dropped in a moment. In particular, be careful of the power unit with the remote sensing function.

(Note) Make short-circuit on 0V side when separate power sources are used for the control power and motor power.

#### (Reference) Selection of Power Supply Protection Circuit Breaker

It is recommended that the power supply protection is conducted on the primary side (AC power side) of the 24V DC power supply unit.

Pay attention to the in-rush current of 24V DC power supply unit and rated cutoff current of the circuit breaker.

- Rated Breaking Current > Short-circuit Current = Primary Power Supply Capacity/Power Voltage
- (Reference) In-rush Current of IAI Power Supply Unit PS241 = 50 to 60A, 3msec

#### • Specifications of DeviceNet Interface

Item	Specification			
Communication Protocol	DeviceNet2.0			
	Group 2 Dedicated Server Network-Powered Insulation Node			
Baud Rate	Automatically follows the master			
Communication System	Master-Slave System (Polling)			
Number of Occupied Channels	Refer to "3.4.1 PLC Address Construction by each Operation Mode" in the Instruction Manual for ERC3 Gateway Unit.			
Number of Occupied Nodes	1 Node			
Communication Cable Length (Note 2)	Baud Rate	Max. Network Length	Total Branch Line Length	Max. Branch Line Length
	500kbps	100m	39m	6m
	250kbps	250m	78m	
	125kbps	500m	156m	
Communications Cable	Use the dedicated cable.			
Connector (Note 1)	MSTBA2.5/5-G-5.08AU (Manufactured by PHOENIX CONTACT or equivalent)			
Consumption Current of Communication Power Supply	60mA			
Communication Power Supply	24V DC (Supplied from DeviceNet)			

Note 1 The cable-side connector is a standard accessory. (PHOENIX CONTACT SMSTB2.5/5-ST-5.08AU)

Note 2 For T branch communication, refer to the Instruction Manuals for the master unit and programmable controller (PLC) to be mounted.

#### • Specifications of CC-Link Interface

Item	Specification					
Communication Protocol	CC-Link ver1.1 or ver2					
Station Type	Remote Device Station (MAX. four stations occupied)					
Baud Rate	10M/5M/2.5M/625k/156kbps					
Communication System	Broadcast Polling System					
Number of Connectable Stations	Refer to "3.4.1 PLC Address Construction by each Operation Mode" in the Instruction Manual for ERC3 Gateway Unit.					
Communication Cable Length (Note 2)	Baud Rate (bps)	10M	5M	2.5M	625k	156k
	Total Cable Length (m)	100	160	400	900	1200
Communications Cable	Use the dedicated cable.					
Connector (Note 1)	MSTB2.5/5-GF-5.08 AU (Manufactured by PHOENIX CONTACT or equivalent)					

Note 1 The cable-side connector is a standard accessory. (PHOENIX CONTACT MSTB2.5/5-STF-5.08 AU)

Note 2 For T branch communication, refer to the Instruction Manuals for the master unit and programmable PLC to be mounted.

#### • Specifications of PROFIBUS-DP Interface

Item	Specification		
Communication Protocol	PROFIBUS-DP		
Baud Rate	Automatically follows the master		
Communication System	Hybrid System (Master-Slave System or Token Passing System)		
Number of Occupied Stations	Refer to "3.4.1 PLC Address Construction by each Operation Mode" in the Instruction Manual for ERC3 Gateway Unit.		
Communication Cable Length (Note 2)	MAX. Total Network	Baud Rate	Cable Type
	100m	12,000/6,000/3,000kbps	Type A Cable
	200m	1,500kbps	
	400m	500kbps	
	1000m	187.5kbps	
1200m	9.6/19.2/93.75kbps		
Communications Cable	STP cable AWG18		
Connector (Note 1)	9-pin female D-sub Connector		
Transmission Path Format	Bus/Tree/Star		

Note 1 Please prepare a 9-pin male D-sub connector for the cable-end connector.

Note 2 For T branch communication, refer to the Instruction Manuals for the master unit and programmable PLC to be mounted.

• Specifications of CompoNet Interface

Item	Specification
Communication System	CompoNet dedicated protocol
Communication Type	Remote I/O communication
Baud Rate	Automatically follows the master
Communication Cable Length	Follows CompoNet specifications
Slave Type	Word-Mixed Slave
Available Node Addresses for Setting	0 to 63 (Setting conducted on controller parameter)
Number of Occupied Channels	Refer to "3.4.1 PLC Address Construction by each Operation Mode" in the Instruction Manual for ERC3 Gateway Unit.
Communications Cable <sup>(Note 1)</sup>	Round Cable (JIS C3306, VCTF2-core) Flat cable I (with no sheathed) Flat cable II (sheathed)
Connector (Controller Side)	XW7D-PB4-R (Manufactured by OMRON or equivalent)

Note 1 Prepare the communication cable separately.

• Specifications of MECHATROLINK-II/II Interface

Item	Specification
Slave Type	Intelligent I/O
Baud Rate	MECHATROLINK I 4Mbps MECHATROLINK II 10Mbps
Max. Transmittable Distance	50m
Min. Distance between Stations	0.5m
Number of occupied Bytes	Refer to "3.4.1 PLC Address Construction by each Operation Mode" in the Instruction Manual for ERC3 Gateway Unit.
Number of Connectable Slaves	MECHATROLINK I 15 stations MECHATROLINK II 30 stations (Repeater is required for connections of more than 17 stations)
Transmission Frequency	1 to 8ms
Data Length	MECHATROLINK I 17 byte MECHATROLINK II 17/32 byte
Settable Node Address Range	61 to 7F [hex.]
Communications Cable <sup>(Note 1)</sup>	Twist Pair Cable with a Shield (characteristic impedance 130Ω)
Connected Connector on Controller Side	DUSB-ARB82-T11A-FA (Manufactured by DDK or equivalent)

Note 1 Prepare the communication cable separately.

• Specifications of EtherNet/IP Interface

Item	Specification
Communication Protocol	IEC61158 (IEEE802.3)
Baud Rate	10BASE-T/100BASE-T (Autonegotiation setting is recommended)
Communication Cable Length	Follows EtherNet/IP specifications (Distance between hub and each node: 100m max.)
Number of Connection	Master Unit
Available Node Addresses for Setting	0.0.0.0 to 255.255.255.255
Communications Cable <sup>(Note 1)</sup>	Category 5e or more (Double shielded cable braided with aluminum foil recommended)
Connector	RJ45 Connector × 1pc

Note 1 Prepare a LAN cable separately for the communication cable.

• Specifications of EtherCAT Interface

Item	Specification
Communication Protocol	IEC61158 type 12
Physical Layer	100Base-TX (IEEE802.3)
Baud Rate	Automatically follows the master
Communication Cable Length	Follows EtherCAT® specifications (Distance between each node: 100m max.)
Slave Type	I/O slave
Available Node Addresses for Setting	0 to 127 (17 to 80: When connected to the master (CJ1W-NC*82) manufactured by OMRON)
Communications Cable <sup>(Note 1)</sup>	Category 5e or more (Double shielded cable braided with aluminum foil recommended)
Connector	RJ45 Connector × 2pcs (Input × 1, Output × 1)
Connect	Daisy chain only

Note 1 Prepare a LAN cable separately for the communication cable.

## External Dimensions

Gateway Unit Main Body

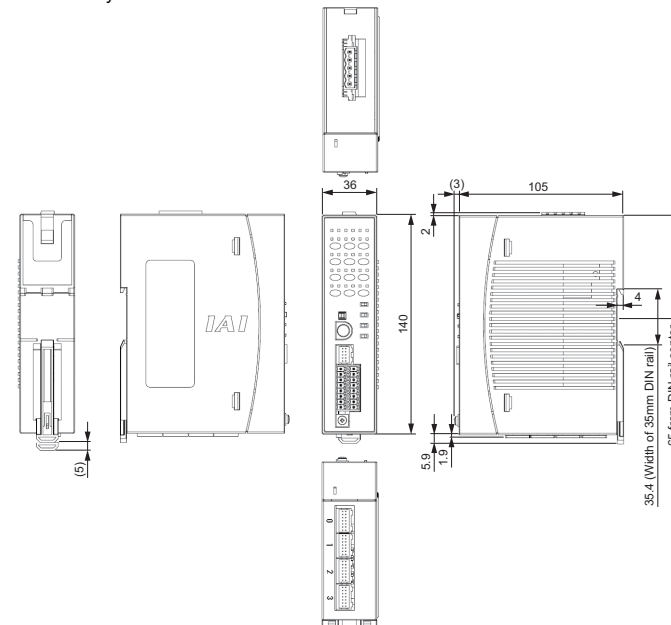

Absolute Battery Box

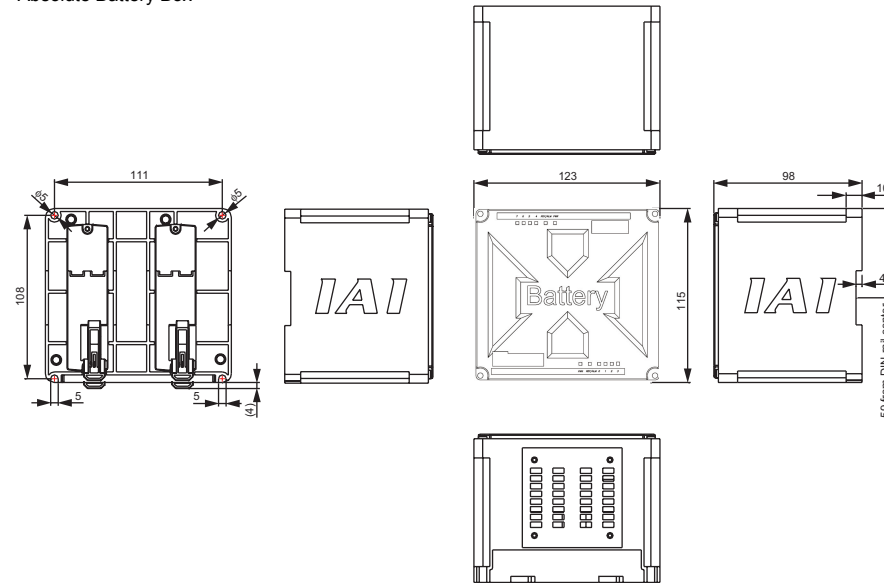

## Installation Environment

This product is capable for use in the environment of pollution degree 2<sup>1</sup> or equivalent.

\*1 Pollution Degree 2 : Environment that may cause non-conductive pollution or transient conductive pollution by frost (IEC60664-1).

1. Installation Environment

Do not use this product in the following environment.

- Location where the surrounding air temperature exceeds the range of 0 to 40°C
- Location where condensation occurs due to abrupt temperature changes
- Location where relative humidity exceeds 85%RH
- Location exposed to corrosive gases or combustible gases
- Location exposed to significant amount of dust, salt or iron powder
- Location subject to direct vibration or impact
- Location exposed to direct sunlight
- Location where the product may come in contact with water, oil or chemical droplets
- Environment that blocks the air vent [Refer to 1.7 Noise Elimination and Mounting Method]

When using the product in any of the locations specified below, provide a sufficient shield.

- Location subject to electrostatic noise
- Location where high electrical or magnetic field is present
- Location with the mains or power lines passing nearby

2. Storage and Preservation Environment

- Storage and preservation environment follows the installation environment. Especially in a long-term storage, consider to avoid condensation of surrounding air.
- Unless specially specified, moisture absorber protection is not included in the package when the machine is delivered. In the case that the machine is to be stored in an environment where dew condensation is anticipated, take the condensation preventive measures from outside of the entire package, or directly after opening the package.

## Installation and Noise Elimination

1. Noise Elimination Grounding (Frame Ground)

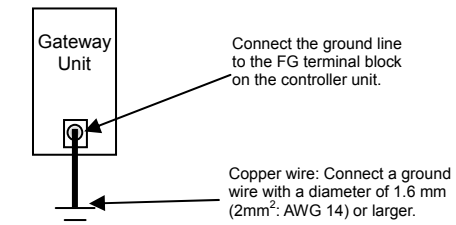

Earth Terminal  
Class D grounding (Formerly Class-III grounding :  
Grounding resistance at 100Ω or less)

2. Precautions regarding wiring method

- 1) Wire is to be twisted for the 24V DC power supply.
- 2) Separate the signal and encoder lines from the power supply and power lines.

3. Noise Sources and Elimination

- Carry out noise elimination measures for electrical devices on the same power path and in the same equipment.
- The following are examples of measures to eliminate noise sources.
- 1) AC solenoid valves, magnet switches and relays  
[Measure] Install a Surge absorber parallel with the coil.
  - 2) DC solenoid valves, magnet switches and relays  
[Measure] Mount the windings and diodes in parallel. Select a diode built-in type for the DC relay.

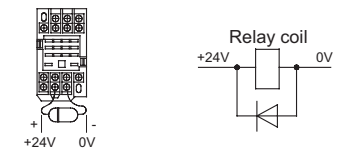
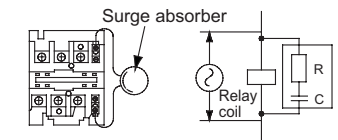
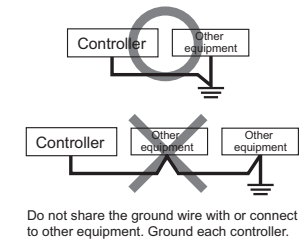

4. Cooling Factors and Installation

Design and Build the system considering the size of the controller box, location of the Gateway Unit and cooling factors to keep the ambient temperature around the Gateway Unit below 40°C.  
Pay a special attention to the battery unit since the performance of it would drop both in the low and high temperatures. Keep it in an environment in the room temperature as much as possible. (Approximately 20°C is the recommended temperature.)

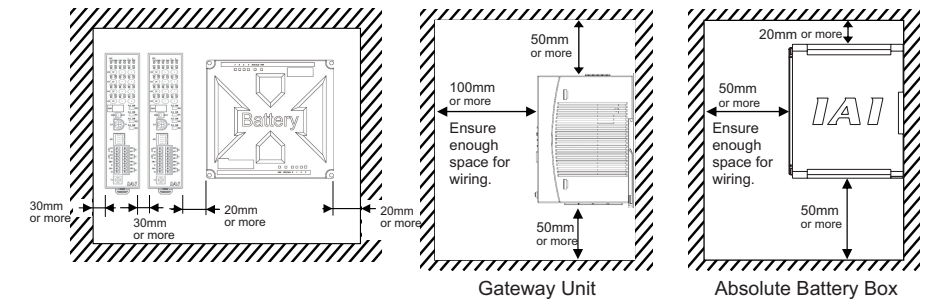

For the Gateway attachment, affix it on the DIN rail. For the attachment of the battery box, use the 4 attachment holes on each corner of the unit or affix it on the DIN rail.

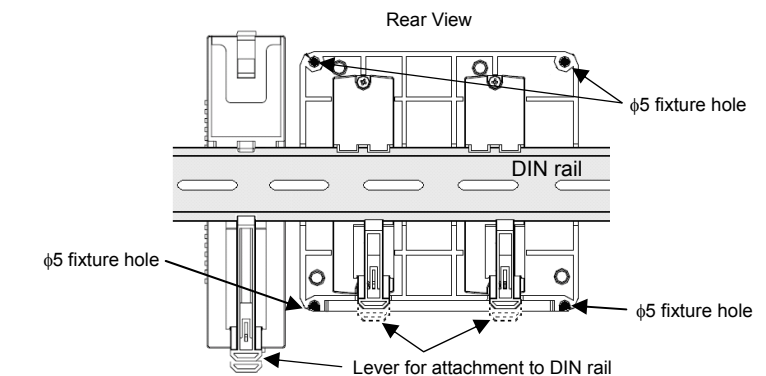

## Operation Pattern Selected

There are five patterns of control methods. Set the most suitable operation pattern for your use with Gateway Parameter Setting Tool.

### • Operation Patterns for PIO Type

Operation Pattern	Description	Overview
Positioner 1	In Positioner 1 Mode, 512 points of position data can be registered at the maximum and is able to stop at the registered positions. Monitoring of the current position is also available.	<p>PLC</p> <ul style="list-style-type: none"> <li>Target Position No. Control Signal</li> <li>Current Position Completion Position No. Status Signal</li> </ul>
Simple Direct Mode	In Simple Direct Mode, the target position can be indicated directly by inputting a value. Monitoring of the current position is also available.	<p>PLC</p> <ul style="list-style-type: none"> <li>Target Position Positioning Width</li> <li>Acceleration/Deceleration Push % Control Signal</li> <li>Current Position Current Value (Command Value)</li> <li>Current Speed (Command Value)</li> <li>Alarm Code Status Signal</li> </ul>
Direct Numeric Specification Mode	The target position, speed acceleration/deceleration and pressing current limit can be indicated with inputting a number. Monitoring of not only the current position, but also the current speed and indicated current are available.	<p>PLC</p> <ul style="list-style-type: none"> <li>Target Position No. Control Signal</li> <li>Completion Position No. Status Signal</li> </ul>
Positioner 2 Mode	This is the operation mode of the position data of 512 points at maximum set in the position table. The monitoring of the current position is not available. This mode is that the transferred data is reduced from Positioner 1 Mode.	<p>PLC</p> <ul style="list-style-type: none"> <li>Target Position No. Control Signal</li> <li>Completion Position No. Status Signal</li> </ul>
Positioner 3 Mode	This is the operation mode of the position data of 256 points at maximum set in the position table. The monitoring of the current position is not available. This is the mode to control with the minimized number of signals to perform the positioning operation by reducing the amount of sent and received data from Positioner 2 Mode.	<p>PLC</p> <ul style="list-style-type: none"> <li>Target Position Control Signal</li> <li>Completion Position No. Status Signal</li> </ul>
I/O	6 types (Note) of control same as for PIO (CON Mode) are available. Note They can be switched around in PIO patterns on ERC3 unit 2 types (Note) of control same as for PIO (MEC Mode) are available. Note They can be switched around in operation patterns on ERC3 unit	Refer to ERC3 Actuator with Integrated Controller Instruction Manual

## Wiring

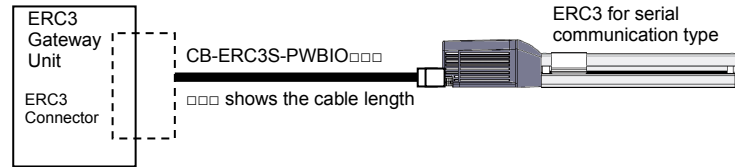
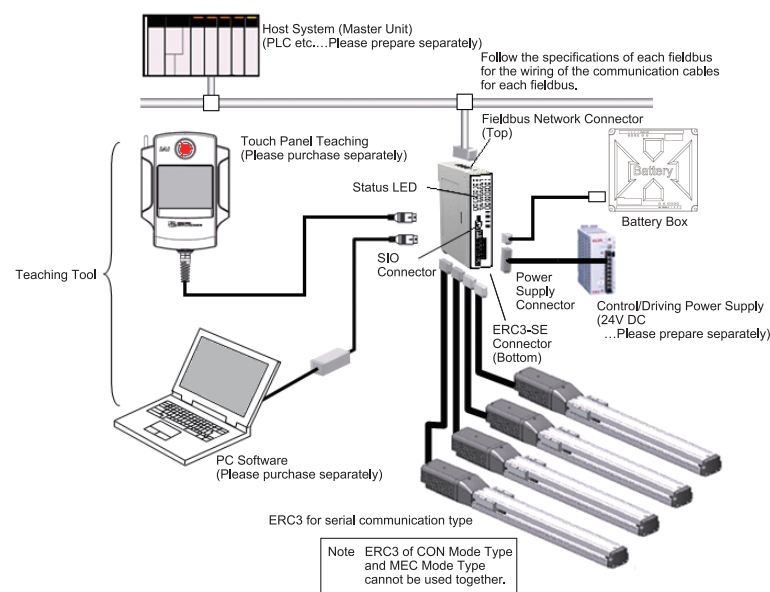

## Power Supply and Emergency Stop Circuit

The following diagram shows an example of how the emergency stop switch for the teaching pendant may be included in the emergency stop circuit you may construct. If supplying power with using a 24V DC, having it turned ON/OFF, keep the 0V connected and have the +24V supplied/cut (cut one side only).

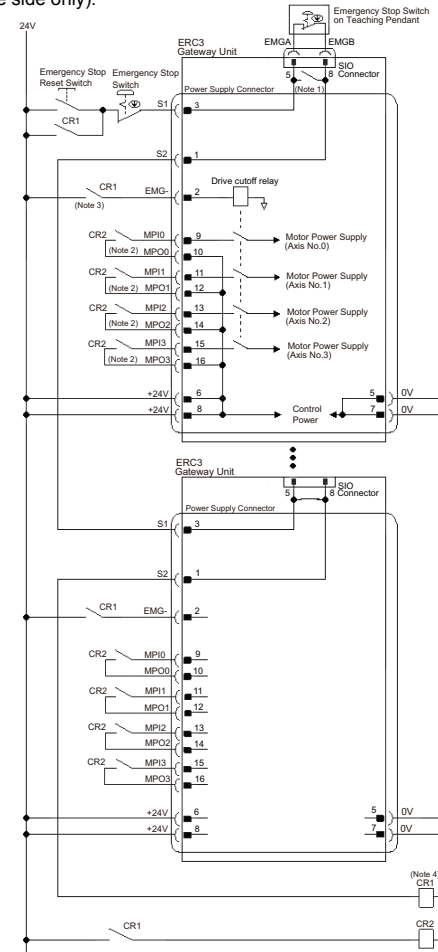

- Note 1 When the teaching pendant is not connected, S1 and S2 become short-circuited inside the controller.  
 Note 2 When the motor driving source is cut off externally for a compliance with the safety category, connect a contact such as a contactor to the wires between MPI\* and MPO\*.  
 Note 3 The rating for the emergency stop signal (EMG-) to turn ON/OFF at contact CR1 is 24V DC and 10mA.  
 Note 4 For CR1, select the one with coil current 0.1A or less.

## DeviceNet Type

Refer to the instruction manuals for Field Network master unit and mounted PLC for the details.

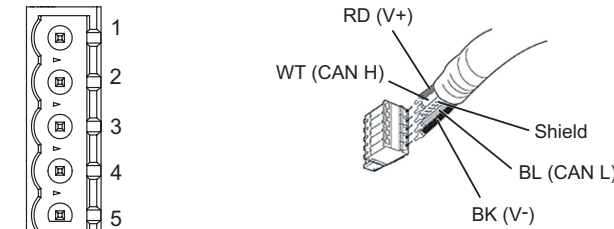

Connector Name	DeviceNet Connector	
Cable Side	SMSTB2.5/5-ST-5.08AU	Enclosed in standard package Manufactured by PHOENIX CONTACT
Controller Side	MSTBA2.5/5-G-5.08AU	

Pin No.	Signal Name (Color)	Description	Applicable cable diameter
1	V- (BK)	Power Supply Cable Negative Side	Dedicated cable for DeviceNet
2	CAN L (BL)	Communication Data Low Side	
3	Shield (None)	Shield	
4	CAN H (WT)	Communication Data High Side	
5	V+ (RD)	Power Supply Cable Positive Side	

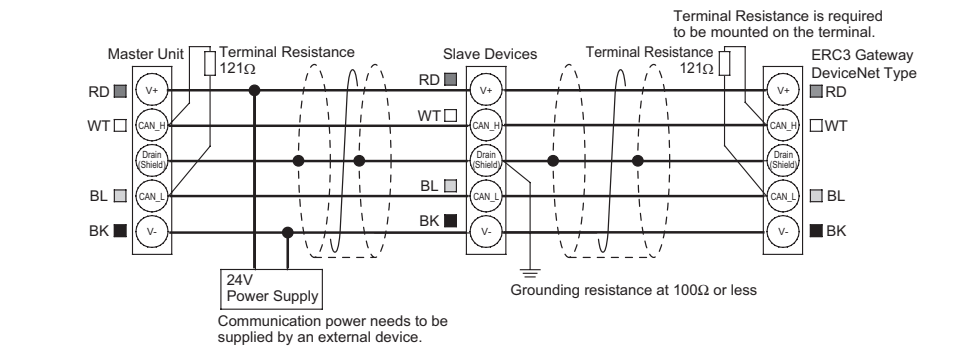

## CC-Link Type

Refer to the instruction manuals for Field Network master unit and mounted PLC for the details.

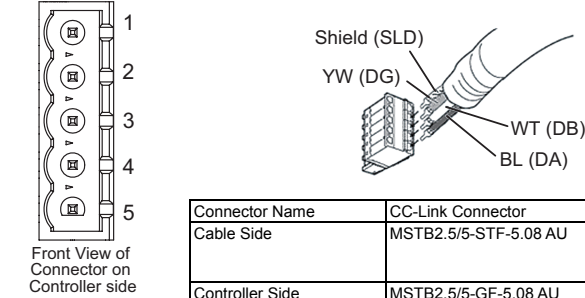

Connector Name	CC-Link Connector	
Cable Side	MSTB2.5/5-STF-5.08 AU	Enclosed in standard package Manufactured by PHOENIX CONTACT
Controller Side	MSTB2.5/5-GF-5.08 AU	

Pin No.	Signal Name (Color)	Description	Applicable cable diameter
1	DA (BL)	Communication Line A	Dedicated cable for CC-Link
2	DB (WT)	Communication Line B	
3	DG (YW)	Digital GND	
4	SLD	Connect the shield of the shielded cable (Connect the FG of the 5 pins and controller FG internally)	
5	FG	Frame Ground (Connect the SLD of the 4 pins and controller FG internally)	

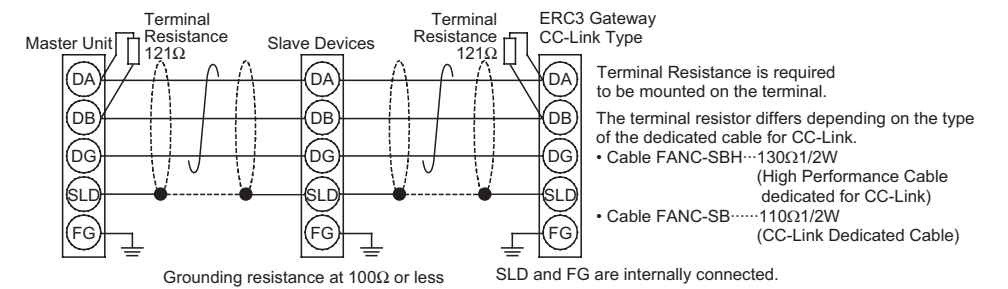

## PROFIBUS-DP Type

Refer to the instruction manuals for each Field Network master unit and mounted PLC for the details.

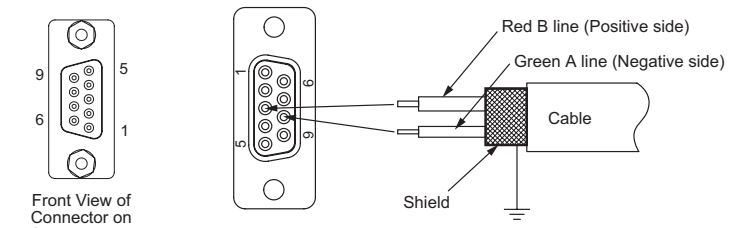

Connector Name	PROFIBUS-DP Connector	
Cable Side	9-pin D-sub Connector (Male)	Please prepare separately
Controller Side	9-pin D-sub Connector (Female)	

Pin No.	Signal Name	Description	Applicable cable diameter
1	NC	Disconnected	PROFIBUS-DP Dedicated Cable
2	NC	Disconnected	
3	B-Line	Communication Line B (RS485)	
4	RTS	Request for Sending	
5	GND	Signal GND (Insulation)	
6	+5V	+5V Output (Insulation)	
7	NC	Disconnected	
8	A-Line	Communication Line A (RS485)	
9	NC	Disconnected	



# Starting Procedures

When using this product for the first time, make sure to avoid mistakes and incorrect wiring by referring to the procedure below. "PC" stated in this section means "PC software".

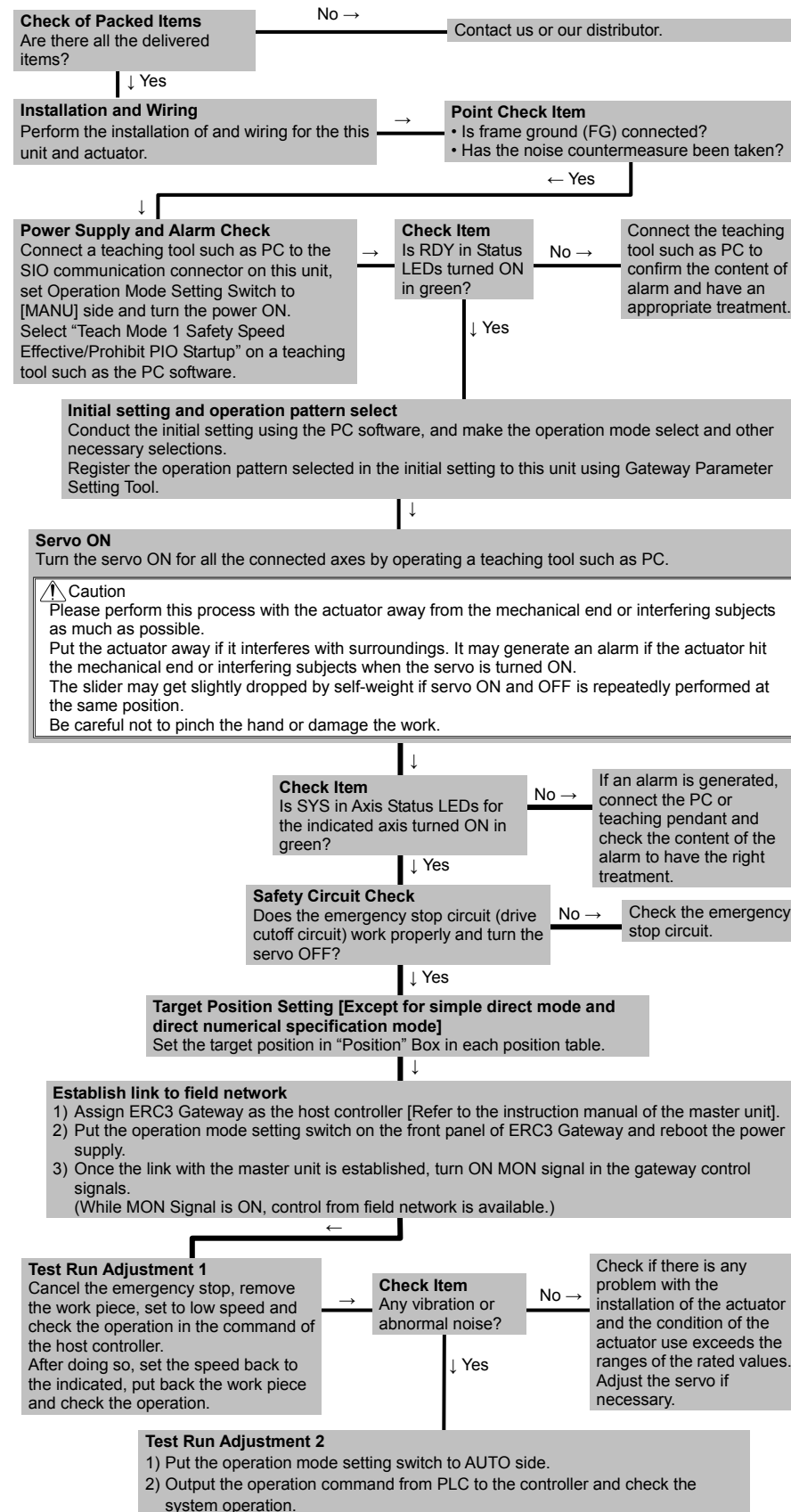

## IAI Corporation

Head Office: 577-1 Obane Shimizu-KU Shizuoka City Shizuoka 424-0103, Japan  
 TEL +81-54-364-5105 FAX +81-54-364-2589  
 website: www.iai-robot.co.jp/

Technical Support available in USA, Europe and China

## IAI America, Inc.

Head Office: 2690 W. 237th Street, Torrance, CA 90505  
 TEL (310) 891-6015 FAX (310) 891-0815  
 Chicago Office: 1261 Hamilton Parkway, Itasca, IL 60143  
 TEL (630) 467-9900 FAX (630) 467-9912  
 Atlanta Office: 1220 Kennestone Circle, Suite 108, Marietta, GA 30066  
 TEL (678) 354-9470 FAX (678) 354-9471  
 website: www.intelligentactuator.com

## IAI Industrieroboter GmbH

Ober der Röth 4, D-65824 Schwalbach am Taunus, Germany  
 TEL 06196-88950 FAX 06196-889524

## IAI (Shanghai) Co., Ltd.

SHANGHAI JIAHUA BUSINESS CENTER A8-303, 808, Hongqiao Rd. Shanghai 200030, China  
 TEL 021-6448-4753 FAX 021-6448-3992  
 website: www.iai-robot.com