

**ROBO Cylinder
Radial Cylinder
RCP4 Actuator
Rod Type
Operation Manual**

===== **Eighth Edition** =====

Motor straight type
Motor reversing type

RA5C, RA6C
RA5R, RA6R

Please Read Before Use

Thank you for purchasing our product.

This Operation Manual explains the handling methods, structure and maintenance of this product, among others, providing the information you need to know to use the product safely.

Before using the product, be sure to read this manual and fully understand the contents explained herein to ensure safe use of the product.

The CD or DVD that comes with the product contains Operation Manuals for IAI products.

When using the product, refer to the necessary portions of the applicable Operation manual by printing them out or displaying them on a PC.

After reading the Operation Manual, keep it in a convenient place so that whoever is handling this product can reference it quickly when necessary.

[Important]

- This Operation Manual is original.
- The product cannot be operated in any way unless expressly specified in this Operation Manual. IAI shall assume no responsibility for the outcome of any operation not specified herein.
- Information contained in this Operation Manual is subject to change without notice for the purpose of product improvement.
- If you have any question or comment regarding the content of this manual, please contact the IAI sales office near you.
- Using or copying all or part of this Operation Manual without permission is prohibited.
- The company names, names of products and trademarks of each company shown in the sentences are registered trademarks.

RC **ROBO** _____
CYLINDER _____

Table of Contents

Safety Guide	1
Precautions	8
International Standards Compliances	9
Names of the Parts	10
1. Specifications Check	11
1.1 Checking the Product	11
1.1.1 Parts	11
1.1.2 Related Operation Manuals for the Each Controller Supported by this Product	11
1.1.3 How to Read the Model Nameplate	11
1.1.4 How to Read the Model Number	12
1.2 Specification	13
1.2.1 Speed	13
1.2.2 Maximum Acceleration and Transportable Weight	15
1.2.3 Driving System • Position Detector	26
1.2.4 Positioning Precision	26
1.2.5 Current Limit Value and Pressing Force	27
1.2.6 Allowable Load and Torque on Rod Tip	31
1.2.7 Rod Flexure (Reference)	32
1.3 Options	33
1.3.1 Brake Type (Model: B)	33
1.3.2 Reversed-home Specification (Model: NM)	33
1.3.3 Flange Bracket (Front) (Model: FL)	33
1.3.4 Scraper (Model: SC)	33
1.3.5 Motor Left Reversed, Motor Right Reversed (Model No. : ML, MR)	33
1.4 Motor • Encoder Cables	34
1.4.1 Cable for PCON-CA controllers	34
1.4.2 Cable for PCON-CA Controllers	36
2. Installation	38
2.1 Transportation	38
2.2 Installation and Storage • Preservation Environment	40
2.3 How to Installation	41
2.3.1 General Rules on Installation	41
2.3.2 Installation of Main Unit	42
3. Connecting with Controller	50
4. Caution for Operation	54

5.	Maintenance Inspection.....	56
5.1	Inspection Items and Schedule	56
5.2	External Visual Inspection	56
5.3	Cleaning.....	56
5.4	Internal Inspections.....	57
5.5	Internal Cleaning.....	58
5.6	Grease Supply	58
5.6.1	What Grease to Use on the Guides.....	58
5.6.2	What Grease to Use on the Ball Screw	58
5.6.3	Grease to be applied on the Rod (Sliding Surface).....	59
5.6.4	How to apply grease	60
5.7	Procedure for Belt Replacement and Tuning.....	63
5.7.1	Inspection of the Belt	63
5.7.2	Belts to be used	63
5.7.3	Replacement of the Belt	64
5.8	Motor Replacement Process	66
5.8.1	RCP4-RA5C, RA6C.....	66
5.8.2	RCP4-RA5R, SA6R.....	68
5.9	Procedure to Replace Scraper (Option).....	70
6.	External Dimensions.....	72
6.1	RA5C	72
6.2	RA6C	73
6.3	RA5R	74
6.4	RA6R	75
7.	Life.....	76
8.	Warranty	77
8.1	Warranty Period	77
8.2	Scope of the Warranty	77
8.3	Honoring the Warranty.....	77
8.4	Limited Liability	77
8.5	Conditions of Conformance with Applicable Standards/Regulations, Etc., and Applications	78
8.6	Other Items Excluded from Warranty	78
	Change History	79

Safety Guide

“Safety Guide” has been written to use the machine safely and so prevent personal injury or property damage beforehand. Make sure to read it before the operation of this product.

Safety Precautions for Our Products

The common safety precautions for the use of any of our robots in each operation.

No.	Operation Description	Description
1	Model Selection	<ul style="list-style-type: none"> ● This product has not been planned and designed for the application where high level of safety is required, so the guarantee of the protection of human life is impossible. Accordingly, do not use it in any of the following applications. <ol style="list-style-type: none"> 1) Medical equipment used to maintain, control or otherwise affect human life or physical health. 2) Mechanisms and machinery designed for the purpose of moving or transporting people (For vehicle, railway facility or air navigation facility) 3) Important safety parts of machinery (Safety device, etc.) ● Do not use the product outside the specifications. Failure to do so may considerably shorten the life of the product. ● Do not use it in any of the following environments. <ol style="list-style-type: none"> 1) Location where there is any inflammable gas, inflammable object or explosive 2) Place with potential exposure to radiation 3) Location with the ambient temperature or relative humidity exceeding the specification range 4) Location where radiant heat is added from direct sunlight or other large heat source 5) Location where condensation occurs due to abrupt temperature changes 6) Location where there is any corrosive gas (sulfuric acid or hydrochloric acid) 7) Location exposed to significant amount of dust, salt or iron powder 8) Location subject to direct vibration or impact ● For an actuator used in vertical orientation, select a model which is equipped with a brake. If selecting a model with no brake, the moving part may drop when the power is turned OFF and may cause an accident such as an injury or damage on the work piece.

No.	Operation Description	Description
2	Transportation	<ul style="list-style-type: none"> ● When carrying a heavy object, do the work with two or more persons or utilize equipment such as crane. ● When the work is carried out with 2 or more persons, make it clear who is to be the leader and who to be the follower(s) and communicate well with each other to ensure the safety of the workers. ● When in transportation, consider well about the positions to hold, weight and weight balance and pay special attention to the carried object so it would not get hit or dropped. ● Transport it using an appropriate transportation measure. The actuators available for transportation with a crane have eyebolts attached or there are tapped holes to attach bolts. Follow the instructions in the operation manual for each model. ● Do not step or sit on the package. ● Do not put any heavy thing that can deform the package, on it. ● When using a crane capable of 1t or more of weight, have an operator who has qualifications for crane operation and sling work. ● When using a crane or equivalent equipments, make sure not to hang a load that weighs more than the equipment's capability limit. ● Use a hook that is suitable for the load. Consider the safety factor of the hook in such factors as shear strength. ● Do not get on the load that is hung on a crane. ● Do not leave a load hung up with a crane. ● Do not stand under the load that is hung up with a crane.
3	Storage and Preservation	<ul style="list-style-type: none"> ● The storage and preservation environment conforms to the installation environment. However, especially give consideration to the prevention of condensation. ● Store the products with a consideration not to fall them over or drop due to an act of God such as earthquake.
4	Installation and Start	<p>(1) Installation of Robot Main Body and Controller, etc.</p> <ul style="list-style-type: none"> ● Make sure to securely hold and fix the product (including the work part). A fall, drop or abnormal motion of the product may cause a damage or injury. Also, be equipped for a fall-over or drop due to an act of God such as earthquake. ● Do not get on or put anything on the product. Failure to do so may cause an accidental fall, injury or damage to the product due to a drop of anything, malfunction of the product, performance degradation, or shortening of its life. ● When using the product in any of the places specified below, provide a sufficient shield. <ol style="list-style-type: none"> 1) Location where electric noise is generated 2) Location where high electrical or magnetic field is present 3) Location with the mains or power lines passing nearby 4) Location where the product may come in contact with water, oil or chemical droplets

No.	Operation Description	Description
4	Installation and Start	<p>(2) Cable Wiring</p> <ul style="list-style-type: none"> ● Use our company's genuine cables for connecting between the actuator and controller, and for the teaching tool. ● Do not scratch on the cable. Do not bend it forcibly. Do not pull it. Do not coil it around. Do not insert it. Do not put any heavy thing on it. Failure to do so may cause a fire, electric shock or malfunction due to leakage or continuity error. ● Perform the wiring for the product, after turning OFF the power to the unit, so that there is no wiring error. ● When the direct current power (+24V) is connected, take the great care of the directions of positive and negative poles. If the connection direction is not correct, it might cause a fire, product breakdown or malfunction. ● Connect the cable connector securely so that there is no disconnection or looseness. Failure to do so may cause a fire, electric shock or malfunction of the product. ● Never cut and/or reconnect the cables supplied with the product for the purpose of extending or shortening the cable length. Failure to do so may cause the product to malfunction or cause fire. <p>(3) Grounding</p> <ul style="list-style-type: none"> ● The grounding operation should be performed to prevent an electric shock or electrostatic charge, enhance the noise-resistance ability and control the unnecessary electromagnetic radiation. ● For the ground terminal on the AC power cable of the controller and the grounding plate in the control panel, make sure to use a twisted pair cable with wire thickness 0.5mm² (AWG20 or equivalent) or more for grounding work. For security grounding, it is necessary to select an appropriate wire thickness suitable for the load. Perform wiring that satisfies the specifications (electrical equipment technical standards). ● Perform Class D Grounding (former Class 3 Grounding with ground resistance 100Ω or below).





No.	Operation Description	Description
4	Installation and Start	<p>(4) Safety Measures</p> <ul style="list-style-type: none"> ● When the work is carried out with 2 or more persons, make it clear who is to be the leader and who to be the follower(s) and communicate well with each other to ensure the safety of the workers. ● When the product is under operation or in the ready mode, take the safety measures (such as the installation of safety and protection fence) so that nobody can enter the area within the robot's movable range. When the robot under operation is touched, it may result in death or serious injury. ● Make sure to install the emergency stop circuit so that the unit can be stopped immediately in an emergency during the unit operation. ● Take the safety measure not to start up the unit only with the power turning ON. Failure to do so may start up the machine suddenly and cause an injury or damage to the product. ● Take the safety measure not to start up the machine only with the emergency stop cancellation or recovery after the power failure. Failure to do so may result in an electric shock or injury due to unexpected power input. ● When the installation or adjustment operation is to be performed, give clear warnings such as "Under Operation; Do not turn ON the power!" etc. Sudden power input may cause an electric shock or injury. ● Take the measure so that the work part is not dropped in power failure or emergency stop. ● Wear protection gloves, goggle or safety shoes, as necessary, to secure safety. ● Do not insert a finger or object in the openings in the product. Failure to do so may cause an injury, electric shock, damage to the product or fire. ● When releasing the brake on a vertically oriented actuator, exercise precaution not to pinch your hand or damage the work parts with the actuator dropped by gravity.
5	Teaching	<ul style="list-style-type: none"> ● When the work is carried out with 2 or more persons, make it clear who is to be the leader and who to be the follower(s) and communicate well with each other to ensure the safety of the workers. ● Perform the teaching operation from outside the safety protection fence, if possible. In the case that the operation is to be performed unavoidably inside the safety protection fence, prepare the "Stipulations for the Operation" and make sure that all the workers acknowledge and understand them well. ● When the operation is to be performed inside the safety protection fence, the worker should have an emergency stop switch at hand with him so that the unit can be stopped any time in an emergency. ● When the operation is to be performed inside the safety protection fence, in addition to the workers, arrange a watchman so that the machine can be stopped any time in an emergency. Also, keep watch on the operation so that any third person can not operate the switches carelessly. ● Place a sign "Under Operation" at the position easy to see. ● When releasing the brake on a vertically oriented actuator, exercise precaution not to pinch your hand or damage the work parts with the actuator dropped by gravity. <p>* Safety protection Fence : In the case that there is no safety protection fence, the movable range should be indicated.</p>

No.	Operation Description	Description
6	Trial Operation	<ul style="list-style-type: none"> ● When the work is carried out with 2 or more persons, make it clear who is to be the leader and who to be the follower(s) and communicate well with each other to ensure the safety of the workers. ● After the teaching or programming operation, perform the check operation one step by one step and then shift to the automatic operation. ● When the check operation is to be performed inside the safety protection fence, perform the check operation using the previously specified work procedure like the teaching operation. ● Make sure to perform the programmed operation check at the safety speed. Failure to do so may result in an accident due to unexpected motion caused by a program error, etc. ● Do not touch the terminal block or any of the various setting switches in the power ON mode. Failure to do so may result in an electric shock or malfunction.
7	Automatic Operation	<ul style="list-style-type: none"> ● Check before starting the automatic operation or rebooting after operation stop that there is nobody in the safety protection fence. ● Before starting automatic operation, make sure that all peripheral equipment is in an automatic-operation-ready state and there is no alarm indication. ● Make sure to operate automatic operation start from outside of the safety protection fence. ● In the case that there is any abnormal heating, smoke, offensive smell, or abnormal noise in the product, immediately stop the machine and turn OFF the power switch. Failure to do so may result in a fire or damage to the product. ● When a power failure occurs, turn OFF the power switch. Failure to do so may cause an injury or damage to the product, due to a sudden motion of the product in the recovery operation from the power failure.

No.	Operation Description	Description
8	Maintenance and Inspection	<ul style="list-style-type: none"> ● When the work is carried out with 2 or more persons, make it clear who is to be the leader and who to be the follower(s) and communicate well with each other to ensure the safety of the workers. ● Perform the work out of the safety protection fence, if possible. In the case that the operation is to be performed unavoidably inside the safety protection fence, prepare the “Stipulations for the Operation” and make sure that all the workers acknowledge and understand them well. ● When the work is to be performed inside the safety protection fence, basically turn OFF the power switch. ● When the operation is to be performed inside the safety protection fence, the worker should have an emergency stop switch at hand with him so that the unit can be stopped any time in an emergency. ● When the operation is to be performed inside the safety protection fence, in addition to the workers, arrange a watchman so that the machine can be stopped any time in an emergency. Also, keep watch on the operation so that any third person can not operate the switches carelessly. ● Place a sign “Under Operation” at the position easy to see. ● For the grease for the guide or ball screw, use appropriate grease according to the Operation Manual for each model. ● Do not perform the dielectric strength test. Failure to do so may result in a damage to the product. ● When releasing the brake on a vertically oriented actuator, exercise precaution not to pinch your hand or damage the work parts with the actuator dropped by gravity. ● The slider or rod may get misaligned OFF the stop position if the servo is turned OFF. Be careful not to get injured or damaged due to an unnecessary operation. ● Pay attention not to lose the cover or untightened screws, and make sure to put the product back to the original condition after maintenance and inspection works. <p>Use in incomplete condition may cause damage to the product or an injury.</p> <p>* Safety protection Fence : In the case that there is no safety protection fence, the movable range should be indicated.</p>
9	Modification and Dismantle	<ul style="list-style-type: none"> ● Do not modify, disassemble, assemble or use of maintenance parts not specified based at your own discretion.
10	Disposal	<ul style="list-style-type: none"> ● When the product becomes no longer usable or necessary, dispose of it properly as an industrial waste. ● When removing the actuator for disposal, pay attention to drop of components when detaching screws. ● Do not put the product in a fire when disposing of it. The product may burst or generate toxic gases.
11	Other	<ul style="list-style-type: none"> ● Do not come close to the product or the harnesses if you are a person who requires a support of medical devices such as a pacemaker. Doing so may affect the performance of your medical device. ● See Overseas Specifications Compliance Manual to check whether complies if necessary. ● For the handling of actuators and controllers, follow the dedicated operation manual of each unit to ensure the safety.

Alert Indication

The safety precautions are divided into “Danger”, “Warning”, “Caution” and “Notice” according to the warning level, as follows, and described in the Operation Manual for each model.

Level	Degree of Danger and Damage	Symbol
Danger	This indicates an imminently hazardous situation which, if the product is not handled correctly, will result in death or serious injury.	 Danger
Warning	This indicates a potentially hazardous situation which, if the product is not handled correctly, could result in death or serious injury.	 Warning
Caution	This indicates a potentially hazardous situation which, if the product is not handled correctly, may result in minor injury or property damage.	 Caution
Notice	This indicates lower possibility for the injury, but should be kept to use this product properly.	 Notice

Precautions

1. Make sure to follow the usage condition, environment and specification range of the product.
In case it is not secured, it may cause a drop in performance or malfunction of the product.
2. Do not attempt to have any handling or operation that is not stated in this operation manual.
3. It is recommended to apply our products for the wiring between the actuator and the controller.
4. Do not attempt to establish the settings for the speed and acceleration/deceleration above the allowable range.
An operation with speed and acceleration/deceleration beyond the allowable range may cause an abnormal noise, vibration, malfunction or shortened life.
5. Set the allowable load of the move on rod tip within the allowable range.
An operation with the load beyond the allowable load of the move on rod tip may cause an abnormal noise, vibration, malfunction or shortened life. If it is extreme, flaking may occur on the guide.
6. Set the load offset distance within the allowable range.
Attaching a load with an load offset distance above the allowable range may cause vibration and abnormal noise.
7. If back and forth operations are performed repeatedly in short distance, it may wear out the film of grease.
Continuous back and forth operation within a distance less than 30mm may cause wear of grease.
As a reference, have approximately 5 cycles of back and forth operation in a distance more than 50mm in every 5,000 to 10,000 cycles to regenerate the oil film. Keep using the actuator with the grease worn out may cause malfunction. If it is extreme, flaking may occur on the guide.
8. Do not attempt to hit the rod against an abstacle with high speed.
It may destroy the coupling.
9. Make sure to attach the actuator properly by following this instruction manual.
Using the product with the actuator not being certainly retained or affixed may cause abnormal noise, vibration, malfunction or shorten the product life.

International Standards Compliances

This actuator complies with the following overseas standard.
Refer to Overseas Standard Compliance Manual (ME0287) for more detailed information.

RoHS Directive	CE Marking
○	○

Names of the Parts

In this Operation Manual, the left and right sides are indicated by looking at the actuator from the motor end, with the actuator placed horizontally, as shown in the figure below.

1. Motor Straight Type

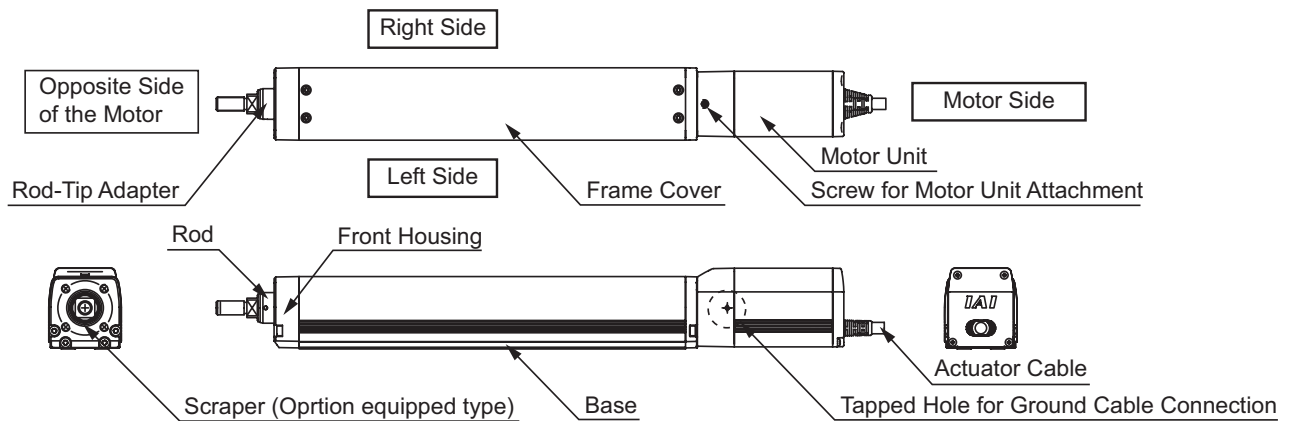

2. Motor Reversing Hollowed Shaft Type

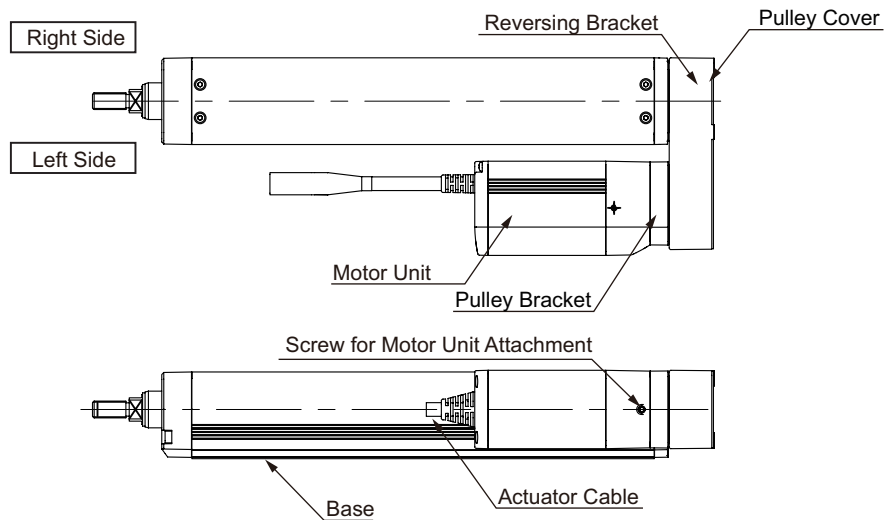

The direction of the motor is either left reversed: ML (shown in figure above) or right reversed: MR.

1. Specifications Check

1.1 Checking the Product

The standard configuration of this product is comprised of the following parts.

See the component list for the details of the enclosed components. If you find any fault or missing parts, contact your local IAI distributor.

1.1.1 Parts

No.	Name	Model number	Quantity	Remarks
1	Actuator	Refer to "How to Read the Model Nameplate" and "How to Read the Model Number."	1	
Accessories				
2	Motor • Encoder Cables ^(Note1)		1	
3	Homing Stickers		1	
4	Nut		1	Refer to list below
5	First Step Guide		1	
6	Operation Manual (CD/DVD)		1	
7	Safety Guide		1	

Note1 The motor • encoder cables supplied vary depending on the controller used.
[Refer to 1.4, "Motor • Encoder Cables."]

(List of Included Nut Type)

Model No.	Nut (M10×1.25)	Nut (M14×1.5)
RCP4-RA5C, RA5R	1	
RCP4-RA6C, RA6R		1

1.1.2 Related Operation Manuals for the Each Controller Supported by this Product

Shown below is a list of the instruction manuals for the controllers related to this product which is recorded in Instruction Manual (DVD).

No.	Name	Control No.
1	Operation Manual for PCON-CA/CFA Controller	ME0289
2	Operation Manual for RC PC Software RCM-101-MW/RCM-101-USB	ME0155
3	Operation Manual for CON-PTA/PDA/PGA	ME0295

1.1.3 How to Read the Model Nameplate

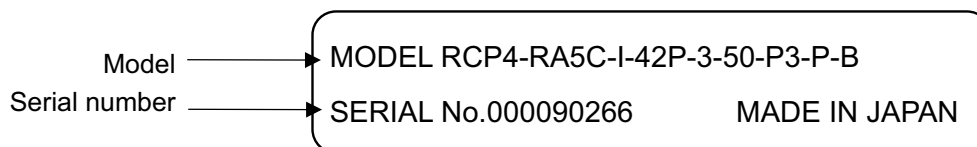

1.1.4 How to Read the Model Number

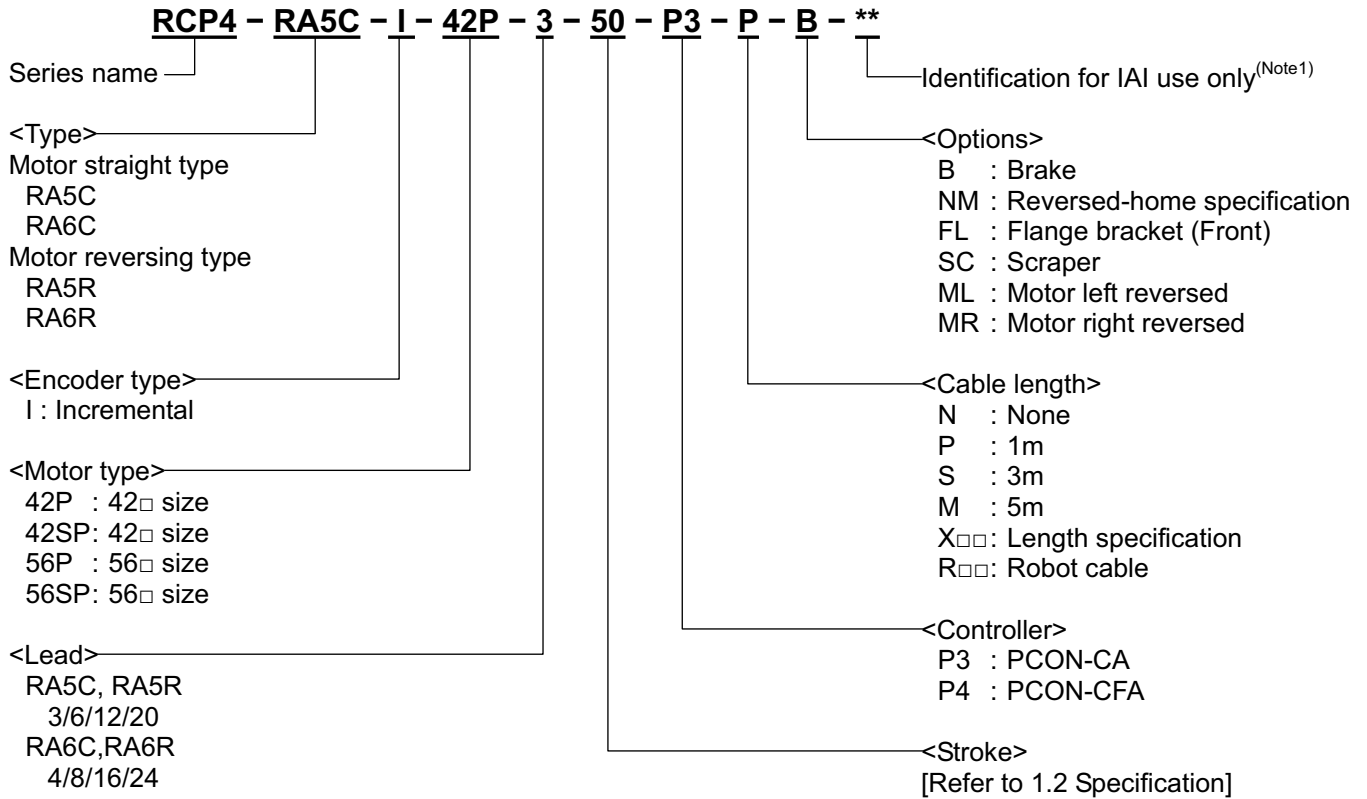

Note 1 Identification for IAI use only: It may be displayed for IAI use. It is not a code to show the model type.
 (Note) The monitor type 42SP is equipped only with Lead 3, and 56SP only with Lead 4, and they are equipped with a brake in standard. There is no variation of reversed type and no-brake type.

1.2 Specification

1.2.1 Speed

[When high-output setting is effective]

Speed limits [Unit: mm/s]

Size	Motor Type	Lead [mm]	Horizontal / Vertical	Stroke [mm]									
				50	100	150	200	250	300	350	400	450	500
RA5C	42P	3	Horizontal	225									
			Vertical	225									
		6	Horizontal	450									
			Vertical	450									
		12	Horizontal	700									
			Vertical	700									
	20	Horizontal	800										
		Vertical	800										
42SP	3	Vertical	80										
RA6C	56P	4	Horizontal	210									
			Vertical	210									
		8	Horizontal	420									
			Vertical	420									
		16	Horizontal	700									
			Vertical	560									
		24	Horizontal	800									
			Vertical	600									
	56SP	4	Vertical	90									
	RA5R	42P	3	Horizontal	225								
Vertical				225									
6			Horizontal	450									
			Vertical	450									
12			Horizontal	700									
			Vertical	700									
20		Horizontal	800										
		Vertical	800										
RA6R	56P	4	Horizontal	175									
			Vertical	175									
		8	Horizontal	420									
			Vertical	350									
		16	Horizontal	560									
			Vertical	560									
		24	Horizontal	800									
			Vertical	800									

[When high-output setting is ineffective]

Strokes and maximum speed limits [Unit: mm/s]

Size	Motor Type	Lead [mm]	Horizontal / Vertical	Stroke [mm]									
				50	100	150	200	250	300	350	400	450	500
RA5C	42P	3	Horizontal	125									
			Vertical	125									
		6	Horizontal	250									
			Vertical	250									
		12	Horizontal	500									
			Vertical	500									
		20	Horizontal	640									
			Vertical	640									
RA6C	56P	4	Horizontal	140									
			Vertical	140									
		8	Horizontal	210									
			Vertical	210									
		16	Horizontal	420									
			Vertical	420									
		24	Horizontal	600									
			Vertical	400									
RA5R	42P	3	Horizontal	125									
			Vertical	125									
		6	Horizontal	250									
			Vertical	250									
		12	Horizontal	500									
			Vertical	500									
		20	Horizontal	640									
			Vertical	640									
RA6R	56P	4	Horizontal	140									
			Vertical	140									
		8	Horizontal	210									
			Vertical	210									
		16	Horizontal	420									
			Vertical	420									
		24	Horizontal	600									
			Vertical	400									

1.2.2 Maximum Acceleration and Transportable Weight

If the transportable weight is smaller than as specified, the acceleration/deceleration can be raised beyond the applicable level.

[When high-output setting for motor straight type is effective]

Type	Motor Type	Lead [mm]	Horizontal / Vertical	Payload Capacity by Acceleration/Deceleration [kg]					
				Velocity [mm/s]	0.1G	0.3G	0.5G	0.7G	1.0G
RA5C	42P	3	Horizontal	0	60	60	50	45	40
				25	60	60	50	45	40
				50	60	60	50	45	40
				75	60	60	50	45	40
				100	60	60	50	45	40
				125	60	60	50	40	30
				150	60	50	40	30	25
				175	60	40	35	25	20
				200	60	35	30	20	14
			225	40	16	16	10	6	
			Vertical	0	20	20	20	–	–
				25	20	20	20	–	–
				50	20	20	20	–	–
				75	20	20	20	–	–
				100	20	20	20	–	–
				125	18	14	10	–	–
				150	14	10	6	–	–
				175	12	6	5	–	–
		200		8	5	4.5	–	–	
		225	5	5	4	–	–		
		6	Horizontal	0	40	40	35	30	25
				50	40	40	35	30	25
				100	40	40	35	30	25
				150	40	40	35	25	25
				200	40	40	30	25	20
				250	40	40	27.5	22.5	18
				300	40	35	25	20	14
				350	40	30	14	12	10
				400	30	18	10	6	5
			450	25	8	3	–	–	
			Vertical	0	10	10	10	–	–
				50	10	10	10	–	–
				100	10	10	10	–	–
				150	10	10	10	–	–
				200	10	10	10	–	–
				250	10	9	8	–	–
300	6			6	6	–	–		
350	5			5	5	–	–		
400	4	3		3	–	–			
450	2	2	1	–	–				

Type	Motor Type	Lead [mm]	Horizontal / Vertical	Payload Capacity by Acceleration/Deceleration [kg]							
				Velocity [mm/s]	0.1G	0.3G	0.5G	0.7G	1.0G		
RA5C	42P	12	Horizontal	0	25	25	18	16	12		
				100	25	25	18	16	12		
				200	25	25	18	16	10		
				300	25	25	18	12	8		
				400	20	20	14	10	6		
				500	15	15	8	6	4		
				600	10	10	6	3	2		
				700	-	6	2	-	-		
		Vertical	0	4	4	4	-	-			
			100	4	4	4	-	-			
			200	4	4	4	-	-			
			300	4	4	4	-	-			
			400	4	4	4	-	-			
			500	4	3.5	3	-	-			
			600	4	3	2	-	-			
			700	-	2	1	-	-			
	20	Horizontal	0	6	6	6	5	5			
			160	6	6	6	5	5			
			320	6	6	6	5	3			
			480	6	6	6	5	3			
			640	-	6	4	3	2			
			800	-	4	3	-	-			
			Vertical	0	1.5	1.5	1.5	-	-		
				160	1.5	1.5	1.5	-	-		
		320		1.5	1.5	1.5	-	-			
		480		1.5	1.5	1.5	-	-			
		640		-	1.5	1.5	-	-			
		800		-	1	1	-	-			
		42SP		3	Vertical	0	35	35	35	-	-
						40	35	35	35	-	-
			50			30	30	30	-	-	
			80			15	15	15	-	-	

Type	Motor Type	Lead [mm]	Horizontal / Vertical	Payload Capacity by Acceleration/Deceleration [kg]					
				Velocity [mm/s]	0.1G	0.3G	0.5G	0.7G	1.0G
RA6C	56P	4	Horizontal	0	80	80	70	65	60
				35	80	80	70	65	60
				70	80	80	70	65	60
				105	80	80	60	50	40
				140	80	50	30	20	15
				175	50	15	–	–	–
				210	20	–	–	–	–
			Vertical	0	28	28	28	–	–
				35	28	28	28	–	–
				70	28	28	28	–	–
				105	22	20	18	–	–
				140	16	12	10	–	–
				175	9	4	–	–	–
				210	2	–	–	–	–
		8	Horizontal	0	60	60	50	45	40
				70	60	60	50	45	40
				140	60	60	50	45	40
				210	60	60	40	31	26
				280	60	34	22	15	11
				350	60	14	5	1	–
				420	15	1	–	–	–
			Vertical	0	18	18	18	–	–
				70	18	18	18	–	–
				140	16	16	12	–	–
				210	10	10	9	–	–
				280	8	7	6	–	–
				350	3	3	2	–	–
				420	2	–	–	–	–

Type	Motor Type	Lead [mm]	Horizontal / Vertical	Payload Capacity by Acceleration/Deceleration [kg]						
				Velocity [mm/s]	0.1G	0.3G	0.5G	0.7G	1.0G	
RA6C	56P	16	Horizontal	0	50	50	40	35	30	
				140	50	50	40	35	30	
				280	50	50	35	25	20	
				420	50	25	18	14	10	
				560	12	10	5	3	2	
				700	3	2	-	-	-	
				0	8	8	8	-	-	
		Vertical	140	8	8	8	-	-		
			280	8	7	7	-	-		
			420	6	4.5	4	-	-		
			560	4	2	1	-	-		
			700	-	-	-	-	-		
			24	Horizontal	0	20	20	18	15	12
					200	20	20	18	15	12
	400	20			20	18	15	10		
	600	15			14	9	7	4		
	Vertical	800		-	5	1	1	-		
		0		3	3	3	-	-		
		200		3	3	3	-	-		
	56SP	4	Vertical	400	3	3	3	-	-	
				600	3	3	2	-	-	
				800	-	-	-	-	-	
				0	55	55	55	-	-	
	45			55	55	55	-	-		
60	45	45	45	-	-					
80	25	25	25	-	-					
90	15	15	15	-	-					

[When high-output setting for motor Reversing type is effective]

Type	Motor Type	Lead [mm]	Horizontal / Vertical	Payload Capacity by Acceleration/Deceleration [kg]					
				Velocity [mm/s]	0.1G	0.3G	0.5G	0.7G	1.0G
RA5R	42P	3	Horizontal	0	60	60	50	45	40
				25	60	60	50	45	40
				50	60	60	50	45	40
				75	60	60	50	45	40
				100	60	60	50	45	40
				125	60	60	50	40	30
				150	60	50	40	30	25
				175	60	40	35	25	20
				200	60	35	30	20	14
			225	40	16	16	10	6	
			Vertical	0	20	20	20	–	–
				25	20	20	20	–	–
				50	20	20	20	–	–
				75	20	20	20	–	–
				100	20	20	20	–	–
				125	18	14	10	–	–
				150	14	10	6	–	–
				175	12	6	5	–	–
		200		8	5	4.5	–	–	
		225	5	5	4	–	–		
		6	Horizontal	0	40	40	35	30	25
				50	40	40	35	30	25
				100	40	40	35	30	25
				150	40	40	35	25	25
				200	40	40	30	25	20
				250	40	40	27.5	22.5	18
				300	40	35	25	20	14
				350	40	30	14	12	10
				400	30	18	10	6	5
			450	25	8	3	–	–	
			Vertical	0	10	10	10	–	–
				50	10	10	10	–	–
				100	10	10	10	–	–
				150	10	10	10	–	–
				200	10	10	10	–	–
				250	10	9	8	–	–
300	6			6	6	–	–		
350	5			5	5	–	–		
400	4	3		3	–	–			
450	2	2	1	–	–				

Type	Motor Type	Lead [mm]	Horizontal / Vertical	Payload Capacity by Acceleration/Deceleration [kg]					
				Velocity [mm/s]	0.1G	0.3G	0.5G	0.7G	1.0G
RA5R	42P	12	Horizontal	0	25	25	18	16	12
				100	25	25	18	16	12
				200	25	25	18	16	10
				300	25	25	18	12	8
				400	20	20	14	10	6
				500	15	15	8	6	4
				600	10	10	6	3	2
			700	–	6	2	–	–	
			Vertical	0	4	4	4	–	–
				100	4	4	4	–	–
				200	4	4	4	–	–
				300	4	4	4	–	–
				400	4	4	4	–	–
				500	4	3.5	3	–	–
		600		4	3	2	–	–	
		700	–	2	1	–	–		
		20	Horizontal	0	6	6	6	5	5
				160	6	6	6	5	5
				320	6	6	6	5	3
				480	6	6	6	5	3
				640	–	6	4	3	2
			800	–	4	3	–	–	
			Vertical	0	1.5	1.5	1.5	–	–
				160	1.5	1.5	1.5	–	–
320	1.5			1.5	1.5	–	–		
480	1.5			1.5	1.5	–	–		
640	–	1.5		1.5	–	–			
800	–	1	1	–	–				

Type	Motor Type	Lead [mm]	Horizontal / Vertical	Payload Capacity by Acceleration/Deceleration [kg]					
				Velocity [mm/s]	0.1G	0.2G	0.3G	0.5G	0.7G
RA6R	56P	4	Horizontal	0	80	80	70	65	60
				35	80	80	70	65	60
				70	80	80	70	65	60
				105	80	80	60	50	40
				140	80	50	10	6	6
				175	40	5	–	–	–
			Vertical	0	28	28	28	–	–
				35	28	28	28	–	–
				70	28	28	28	–	–
				105	22	20	18	–	–
				140	13	6	3	–	–
				175	4	–	–	–	–
		8	Horizontal	0	60	60	50	45	40
				70	60	60	50	45	40
				140	60	60	50	45	40
				210	60	60	40	31	26
				280	60	26	16	10	8
				350	30	3	–	–	–
			Vertical	0	18	18	18	–	–
				70	18	18	18	–	–
				140	16	16	12	–	–
				210	10	10	9	–	–
				280	8	5	3	–	–
				350	3	1	–	–	–
RA6R	56P	16	Horizontal	0	50	50	40	35	30
				140	50	50	40	35	30
				280	50	50	35	25	20
				420	50	25	18	14	10
				560	12	10	5	3	2
				0	8	8	8	–	–
			Vertical	140	8	8	8	–	–
				280	8	7	7	–	–
				420	4.5	4.5	4	–	–
				560	2	1	1	–	–
				0	20	20	18	15	12
				200	20	20	18	15	12
		24	Horizontal	400	20	20	18	15	10
				600	15	14	9	7	4
				800	–	3	1	–	–
			Vertical	0	3	3	3	–	–
				200	3	3	3	–	–
				400	3	3	3	–	–
		600	3	3	2	–	–		

[When high-output setting for motor straight type is ineffective]

Type	Motor Type	Lead [mm]	Horizontal / Vertical	Payload Capacity by Acceleration/Deceleration [kg]						
				Velocity [mm/s]	0.1G	0.2G	0.3G	0.5G	0.7G	
RA5C	42P	3	Horizontal	0	-	40	-	-	-	
				25	-	40	-	-	-	
				50	-	40	-	-	-	
				75	-	40	-	-	-	
				100	-	40	-	-	-	
				125	-	40	-	-	-	
			Vertical	0	-	20	-	-	-	
				25	-	20	-	-	-	
				50	-	16	-	-	-	
				75	-	12	-	-	-	
				100	-	9	-	-	-	
				125	-	5	-	-	-	
		6	Horizontal	0	-	40	-	-	-	
				50	-	40	-	-	-	
				100	-	40	-	-	-	
				150	-	40	-	-	-	
				200	-	35	-	-	-	
				250	-	10	-	-	-	
			Vertical	0	-	10	-	-	-	
				50	-	10	-	-	-	
				100	-	10	-	-	-	
				150	-	8	-	-	-	
				200	-	5	-	-	-	
				250	-	3	-	-	-	
		12	Horizontal	0	-	25	-	-	-	
				100	-	25	-	-	-	
				200	-	25	-	-	-	
				300	-	20	-	-	-	
				400	-	10	-	-	-	
				500	-	5	-	-	-	
				Vertical	0	-	4	-	-	-
					100	-	4	-	-	-
					200	-	4	-	-	-
			300		-	3	-	-	-	
			400		-	2	-	-	-	
			500		-	1	-	-	-	
	20		Horizontal		0	-	-	6	-	-
					160	-	-	6	-	-
					320	-	-	6	-	-
				480	-	-	4	-	-	
				640	-	-	3	-	-	
			Vertical	0	-	1.5	-	-	-	
		160		-	1.5	-	-	-		
		320		-	1.5	-	-	-		
		480		-	1	-	-	-		
	42SP	3	Vertical	640	-	0.5	-	-	-	
				0	-	35	-	-	-	
				30	-	35	-	-	-	
40				-	20	-	-	-		
50				-	15	-	-	-		
80				-	5	-	-	-		

Type	Motor Type	Lead [mm]	Horizontal / Vertical	Payload Capacity by Acceleration/Deceleration [kg]					
				Velocity [mm/s]	0.1G	0.2G	0.3G	0.5G	0.7G
RA6C	56P	4	Horizontal	0	–	55	–	–	–
				35	–	55	–	–	–
				70	–	55	–	–	–
				105	–	55	–	–	–
			Vertical	140	–	35	–	–	–
				0	–	26	–	–	–
				35	–	26	–	–	–
				70	–	15	–	–	–
		8	Horizontal	105	–	4	–	–	–
				140	–	2	–	–	–
				0	–	50	–	–	–
				70	–	50	–	–	–
			Vertical	140	–	50	–	–	–
				210	–	30	–	–	–
				0	–	17.5	–	–	–
				70	–	17.5	–	–	–
		16	Horizontal	140	–	7	–	–	–
				210	–	2	–	–	–
				0	–	40	–	–	–
				140	–	40	–	–	–
			Vertical	280	–	30	–	–	–
				420	–	15	–	–	–
				0	–	5	–	–	–
				140	–	5	–	–	–
		24	Horizontal	280	–	3	–	–	–
				420	–	1	–	–	–
				0	–	–	18	–	–
				200	–	–	18	–	–
			Vertical	400	–	–	10	–	–
				600	–	–	1	–	–
				0	–	3	–	–	–
				200	–	3	–	–	–
		600	–	–	–	–	–	–	
			400	–	2	–	–	–	
			600	–	–	–	–	–	
			600	–	–	–	–	–	

[When high-output setting for motor reversing type is ineffective]

Type	Motor Type	Lead [mm]	Horizontal / Vertical	Payload Capacity by Acceleration/Deceleration [kg]					
				Velocity [mm/s]	0.1G	0.2G	0.3G	0.5G	0.7G
RA5R	42P	3	Horizontal	0	-	40	-	-	-
				25	-	40	-	-	-
				50	-	40	-	-	-
				75	-	40	-	-	-
				100	-	40	-	-	-
				125	-	40	-	-	-
			Vertical	0	-	20	-	-	-
				25	-	20	-	-	-
				50	-	16	-	-	-
				75	-	12	-	-	-
				100	-	9	-	-	-
				125	-	5	-	-	-
		6	Horizontal	0	-	40	-	-	-
				50	-	40	-	-	-
				100	-	40	-	-	-
				150	-	40	-	-	-
				200	-	35	-	-	-
				250	-	10	-	-	-
			Vertical	0	-	10	-	-	-
				50	-	10	-	-	-
				100	-	10	-	-	-
				150	-	8	-	-	-
				200	-	5	-	-	-
				250	-	3	-	-	-
		12	Horizontal	0	-	25	-	-	-
				100	-	25	-	-	-
				200	-	25	-	-	-
				300	-	20	-	-	-
				400	-	10	-	-	-
				500	-	5	-	-	-
			Vertical	0	-	4	-	-	-
				100	-	4	-	-	-
				200	-	4	-	-	-
				300	-	3	-	-	-
				400	-	2	-	-	-
				500	-	1	-	-	-
		20	Horizontal	0	-	-	6	-	-
				160	-	-	6	-	-
				320	-	-	6	-	-
				480	-	-	4	-	-
				640	-	-	3	-	-
				0	-	1.5	-	-	-
			Vertical	160	-	1.5	-	-	-
				320	-	1.5	-	-	-
				480	-	1	-	-	-
				640	-	0.5	-	-	-

Type	Motor Type	Lead [mm]	Horizontal / Vertical	Payload Capacity by Acceleration/Deceleration [kg]						
				Velocity [mm/s]	0.1G	0.2G	0.3G	0.5G	0.7G	
RA6R	56P	4	Horizontal	0	–	55	–	–	–	
				35	–	55	–	–	–	
				70	–	55	–	–	–	
				105	–	55	–	–	–	
				140	–	5	–	–	–	
			Vertical	0	–	26	–	–	–	
				35	–	26	–	–	–	
				70	–	15	–	–	–	
				105	–	4	–	–	–	
				140	–	0.5	–	–	–	
			8	Horizontal	0	–	50	–	–	–
					70	–	50	–	–	–
		140			–	50	–	–	–	
		210			–	30	–	–	–	
		0			–	17.5	–	–	–	
		Vertical		70	–	17.5	–	–	–	
				140	–	7	–	–	–	
				210	–	2	–	–	–	
				0	–	40	–	–	–	
				140	–	40	–	–	–	
		16		Horizontal	280	–	30	–	–	–
					420	–	6	–	–	–
			0		–	5	–	–	–	
			140		–	5	–	–	–	
			280		–	3	–	–	–	
			Vertical	420	–	0.5	–	–	–	
				0	–	–	18	–	–	
				200	–	–	18	–	–	
				400	–	–	10	–	–	
				600	–	–	1	–	–	
			24	Horizontal	0	–	3	–	–	–
					200	–	3	–	–	–
		400			–	2	–	–	–	
		Vertical		600	–	–	–	–	–	



Caution: Do not set speeds and accelerations/decelerations equal to or greater than the respective ratings. Doing so may result in vibration, failure or shorter life.
 If any acceleration/deceleration equal to or greater than the rated acceleration/deceleration is set, a creep phenomenon or slipped coupling may occur.

1.2.3 Driving System • Position Detector

Type	Motor Type	Lead	No. of Encoder Pulses	Ball Screw Type			
				Type	Diameter	Accuracy	
RA5C RA5R	42P	3	800	Rolled	φ10mm	C10	
		6					
		12					
		20					
RA5C	42SP	3		800	Rolled	φ10mm	C10
RA6C RA6R	56P	4					
		8					
		16					
		24					
RA6C	56SP	4	800		Rolled	φ12mm	C10

1.2.4 Positioning Precision

Type	lead	Item	Tolerance
RA5C RA5R	3, 6, 12	Positioning repeatability	±0.02mm
		Lost motion	0.1mm or less
	20	Positioning repeatability	±0.03mm
		Lost motion	0.1mm or less
RA6C RA6R	4, 8, 16	Positioning repeatability	±0.02mm
		Lost motion	0.1mm or less
	24	Positioning repeatability	±0.03mm
		Lost motion	0.1mm or less

This is an option already attached when it is shipped out from the factory.
It does not include the consideration of time-dependent change as it is used.

1.2.5 Current Limit Value and Pressing Force

[1] RA5C, RA5R Motor Type 42P

Current Limit Value	Lead 3 [N]	Lead 6 [N]	Lead 12 [N]	Lead 20 [N]
20%	106	53	26	16
30%	159	79	40	24
40%	211	106	53	32
50%	264	132	66	40
60%	317	159	79	48
70%	370	185	93	56

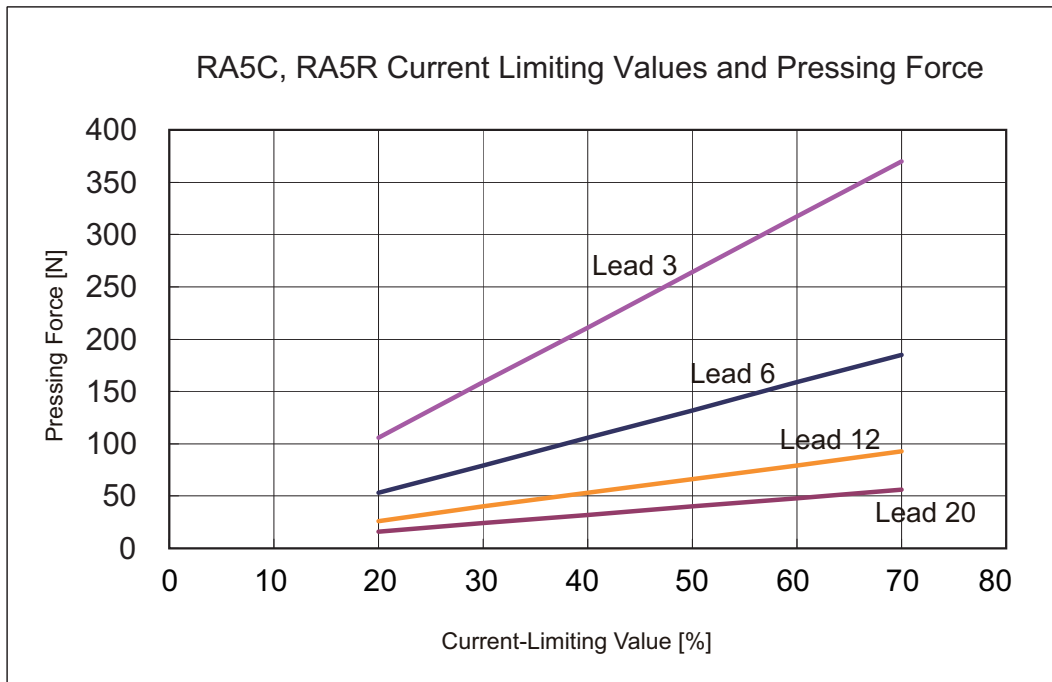

- Caution:**
- (1) The relation of the current limit and the pressing force is a reference when assuming the speed is 20mm/s.
 - (2) There is a little variance in the actual pressing force. The variance of the pressing force becomes large when the current limit value is low.
 - (3) Use the product within the range in the graph for the current limit value. Pressing force will not be stable if used below 20%. There is even a case that it would not operate. An operation cannot be made also when it is beyond 70%. Doing so may cause degradation in the motor coil insulation by heat radiation, which results in shortening the product life.
 - (4) When the approach speed to the pressing start position (setting in the position table) is 20mm/s or less, pressing will be performed with the approach speed. In such a case also the pressing force will be unstable. In such cases, check in advance that the actuator can be used with no problem before omit using.

[2] RA5C Motor Type 42SP

Current Limit Value	Lead 3 [N]
20%	370
30%	500
40%	620
50%	750

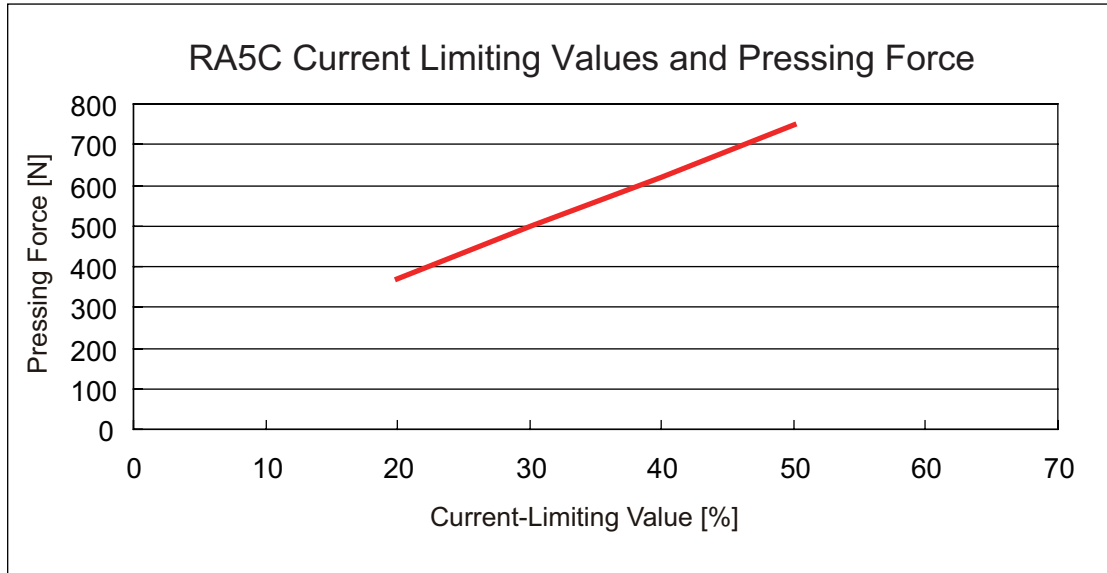

- ⚠ Caution:**
- (1) The relation of the current limit and the pressing force is a reference when assuming the speed is 20mm/s.
 - (2) There is a little variance in the actual pressing force. The variance of the pressing force becomes large when the current limit value is low.
 - (3) Use the product within the range in the graph for the current limit value. Pressing force will not be stable if used below 20%. There is even a case that it would not operate. An operation cannot be made also when it is beyond 50%. Doing so may cause degradation in the motor coil insulation by heat radiation, which results in shortening the product life.
 - (4) When the approach speed to the pressing start position (setting in the position table) is 20mm/s or less, pressing will be performed with the approach speed. In such a case also the pressing force will be unstable. In such cases, check in advance that the actuator can be used with no problem before omit using.

[3] RA6C, RA6R Motor Type 56P

Current Limit Value	Lead 4 [N]	Lead 8 [N]	Lead 16 [N]	Lead 24 [N]
20%	312	156	78	52
30%	469	234	117	78
40%	625	312	156	104
50%	781	391	195	130
60%	937	469	234	156
70%	1094	547	273	182

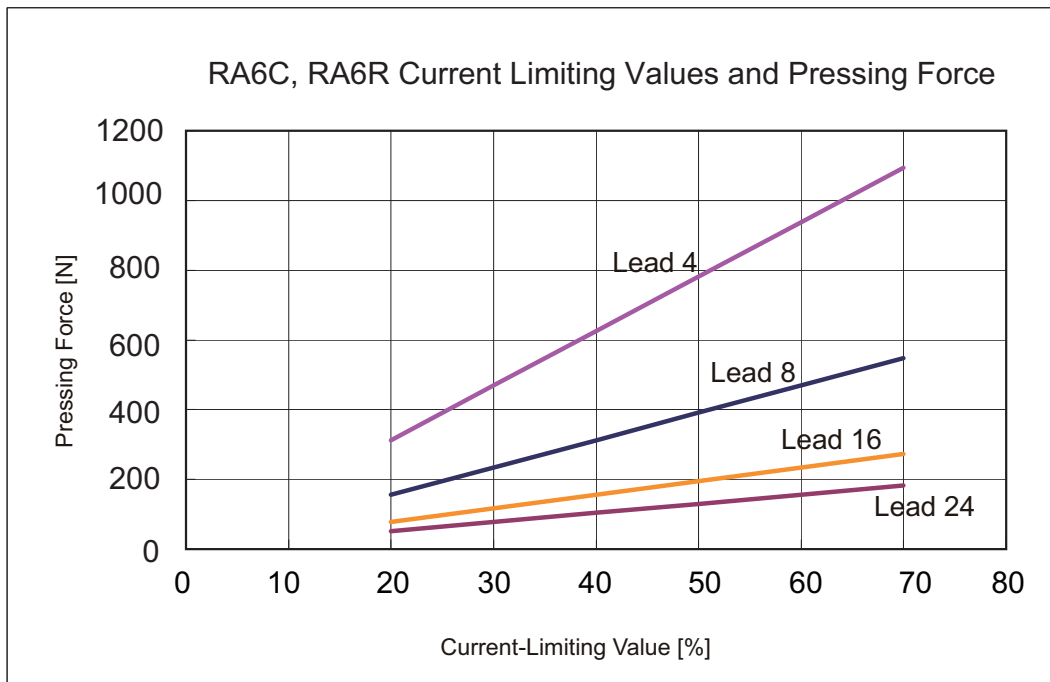

- ⚠ Caution:**
- (1) The relation of the current limit and the pressing force is a reference when assuming the speed is 20mm/s.
 - (2) There is a little variance in the actual pressing force. The variance of the pressing force becomes large when the current limit value is low.
 - (3) Use the product within the range in the graph for the current limit value. Pressing force will not be stable if used below 20%. There is even a case that it would not operate. An operation cannot be made also when it is beyond 70%. Doing so may cause degradation in the motor coil insulation by heat radiation, which results in shortening the product life.
 - (4) When the approach speed to the pressing start position (setting in the position table) is 20mm/s or less, pressing will be performed with the approach speed. In such a case also the pressing force will be unstable. In such cases, check in advance that the actuator can be used with no problem before omit using.

[4] RA6C Motor Type 56SP

Current Limit Value	Lead 4 [N]
20%	470
30%	670
40%	873
50%	1106

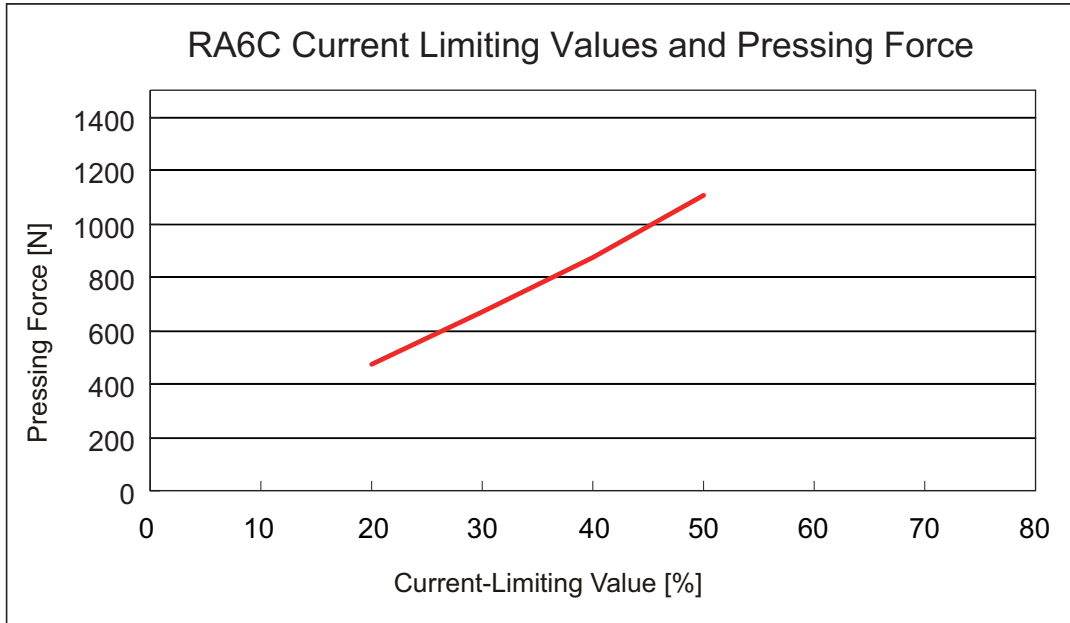

- Caution:
- (1) The relation of the current limit and the pressing force is a reference when assuming the speed is 20mm/s.
 - (2) There is a little variance in the actual pressing force. The variance of the pressing force becomes large when the current limit value is low.
 - (3) Use the product within the range in the graph for the current limit value. Pressing force will not be stable if used below 20%. There is even a case that it would not operate. An operation cannot be made also when it is beyond 50%. Doing so may cause degradation in the motor coil insulation by heat radiation, which results in shortening the product life.
 - (4) When the approach speed to the pressing start position (setting in the position table) is 20mm/s or less, pressing will be performed with the approach speed. In such a case also the pressing force will be unstable. In such cases, check in advance that the actuator can be used with no problem before omit using.

1.2.6 Allowable Load and Torque on Rod Tip

- RCP4-RA5C/RA6C/RA5R/RA6R actuator possesses a built-in guide structure that enables it to apply a side-way load (radial load) and torque. Make sure not to exceed the load indicated in the specification table. Applying excess load may cause an operation failure, parts malfunction and shortened life.

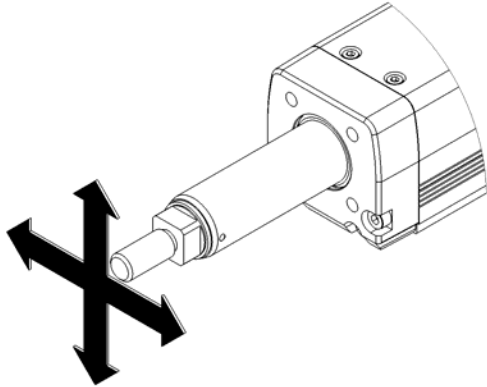

Should be below allowable load
Do not attempt to apply impact load

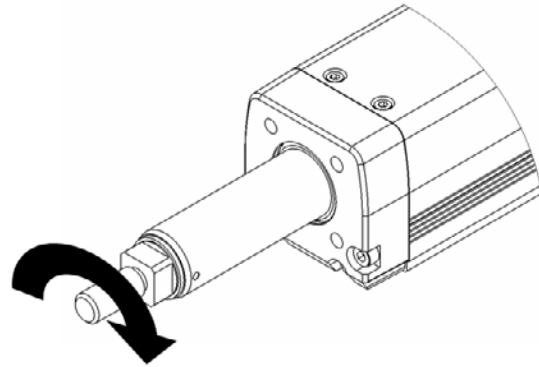

Should be below allowable torque

RCP4-RA5

Item		Stroke	50	100	150	200	250	300	350	400
Rod Tip Allowable Static Load	[N]		65.6	51.2	41.7	34.9	29.8	25.7	22.4	19.7
Rod Tip Dynamic Static Load (Operating life 5000km Remaining Probability 90%)	[N]	Load Offset Distance 0 mm	32.4	23.6	18.1	14.4	11.6	9.5	7.7	6.2
	[N]	Load Offset Distance 0 mm	25.6	19.7	15.7	12.7	10.4	8.6	7.1	5.7
Load Offset Distance (Center of overhang load gravity)	[mm]		100 or less							
Rod Tip Allowable Static Torque	[N•m]		6.6	5.2	4.3	3.7	3.2	2.8	2.6	2.3
Rod Tip Dynamic Static Torque	[N•m]		2.6	2.0	1.6	1.3	1.0	0.9	0.7	0.6
Rod Non-Rotation Accuracy (Note 1)	[deg]		0							

RCP4-RA6

Item		Stroke	50	100	150	200	250	300	350	400	450	500
Rod Tip Allowable Static Load	[N]		112.7	91.5	76.7	65.7	57.25	50.4	44.8	40.2	36.2	32.7
Rod Tip Dynamic Static Load (Operating life 5000km Remaining Probability 90%)	[N]	Load Offset Distance 0 mm	49.0	37.4	29.9	24.5	20.4	17.1	14.5	12.3	10.3	8.6
	[N]	Load Offset Distance 0 mm	38.7	31.0	25.5	21.4	18.1	15.4	13.2	11.2	9.5	8.0
Load Offset Distance (Center of overhang load gravity)	[mm]		100 or less									
Rod Tip Allowable Static Torque	[N•m]		11.4	9.3	7.9	6.8	6.0	5.4	4.9	4.5	4.1	3.8
Rod Tip Dynamic Static Torque	[N•m]		3.9	3.1	2.5	2.1	1.8	1.5	1.3	1.1	1.0	0.8
Rod Non-Rotation Accuracy (Note 1)	[deg]		0									

(Note 1) It shows the displacement angle in the rod rotational direction at no load.

1.2.7 Rod Flexure (Reference)

(Note) This is the flexure of the rod when the actuator is installed vertically. It does not include the flexure caused by the weight of itself.

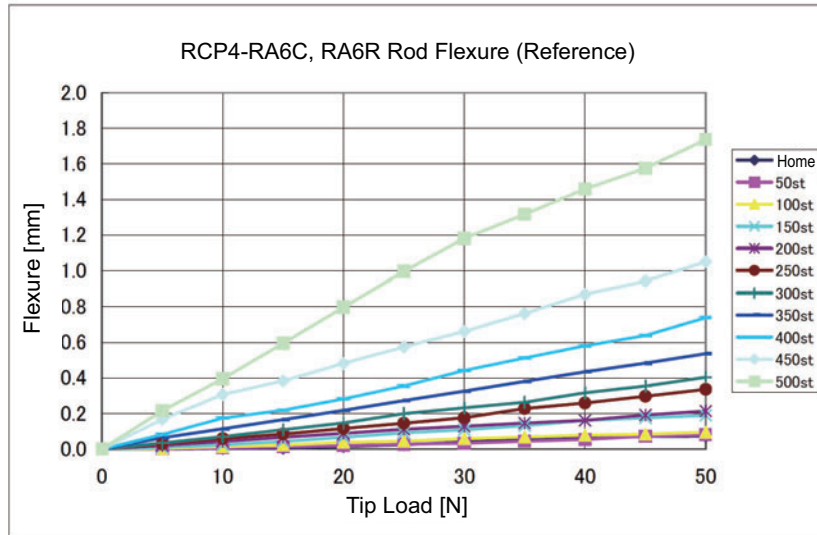
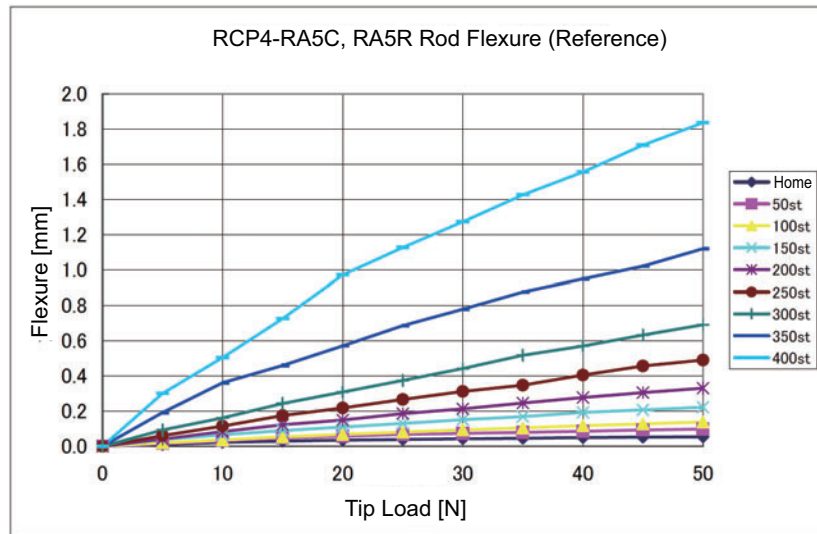

1.3 Options

1.3.1 Brake Type (Model: B)

The brake is a mechanism designed to prevent the rod from dropping on a vertically installed actuator when the power or servo is turned OFF.

Use the brake to prevent the installed load, etc., from being damaged due to the falling rod.

(Note) The motor types 42SP and 56SP are equipped with a brake in standard. There is no option without brake.

1.3.2 Reversed-home Specification (Model: NM)

The standard home position is on the motor side. However, the motor position will be reversed if it is desirable in view of the layout of the system, etc.

(Note) The home position is adjusted at the factory before shipment. If you wish to change the home after the delivery of your actuator, you must return the actuator to IAI for adjustment.

1.3.3 Flange Bracket (Front) (Model: FL)

This is the flange bracket to attach on the front of the main unit. The model code is indicated with FL.

1.3.4 Scraper (Model: SC)

It is attached on the part where the rod moves in and out to prevent dust from getting inside the unit from the outside. (This is an option already attached when it is shipped out from the factory. It is necessary to dismantle and assemble back if it is required to be attached afterwards.)

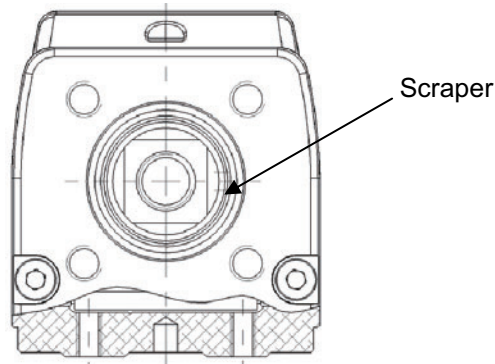

1.3.5 Motor Left Reversed, Motor Right Reversed (Model No. : ML, MR)

From the view of the motor side, the type with the motor reversed to the left is ML, and the motor reversed to the right is MR.

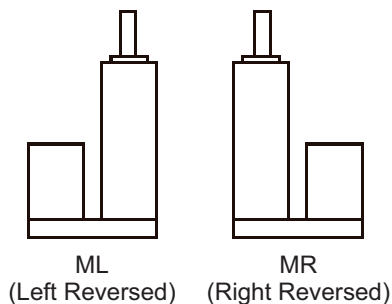

1.4 Motor • Encoder Cables

1.4.1 Cable for PCON-CA controllers

[1] Motor • Encoder Integrated Cables

CB-CA-MPA□□□

□□□ indicates the cable length (L) (Example: 030=3m), Max.20m

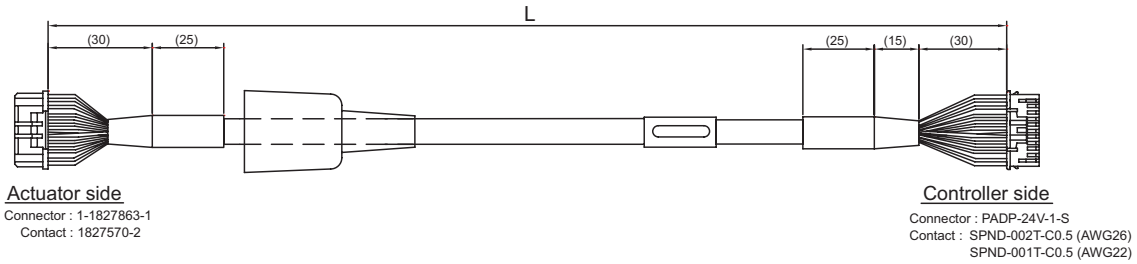

Connection diagram

Actuator side			Controller side		
Pin No.	Symbol	Color	Pin No.	Symbol	Color
A1	ϕ A/U	BL(AWG22/19)	1	ϕ A/U	BL(AWG22/19)
B1	VMM/V	OR(AWG22/19)	2	VMM/V	OR(AWG22/19)
A2	ϕ A/W	GN(AWG22/19)	5	ϕ A/W	GN(AWG22/19)
B2	ϕ B/-	BR(AWG22/19)	3	ϕ B/-	BR(AWG22/19)
A3	VMM/-	GY(AWG22/19)	4	VMM/-	GY(AWG22/19)
B3	ϕ B/-	RD(AWG22/19)	6	ϕ B/-	RD(AWG22/19)
A4	LS+/BK+	BK(AWG26)	7	LS+/BK+	BK(AWG26)
B4	LS-/BK-	YW(AWG26)	8	LS-/BK-	YW(AWG26)
A6	-/A+	BL(AWG26)	11	-/A+	BL(AWG26)
B6	-/A-	OR(AWG26)	12	-/A-	OR(AWG26)
A7	A+/B+	GN(AWG26)	13	A+/B+	GN(AWG26)
B7	A-/B-	BR(AWG26)	14	A-/B-	BR(AWG26)
A8	B+/Z+	GY(AWG26)	15	B+/Z+	GY(AWG26)
B8	B-/Z-	RD(AWG26)	16	B-/Z-	RD(AWG26)
A5	BK+/LS+	BL(AWG26)	9	BK+/LS+	BL(AWG26)
B5	BK-/LS-	OR(AWG26)	10	BK-/LS-	OR(AWG26)
A9	LS_GND	GN(AWG26)	20	LS_GND	GN(AWG26)
B9	VPS	BR(AWG26)	18	VPS	BR(AWG26)
A10	VCC	GY(AWG26)	17	VCC	GY(AWG26)
B10	GND	RD(AWG26)	19	GND	RD(AWG26)
A11	—	—	21	—	—
B11	FG	BK	22	—	—
			23	—	—
			24	FG	BK

[2] Motor • Encoder Integrated Robot Cables Robot Type

CB-CA-MPA□□□-RB

□□□ indicates the cable length (L) (Example: 030=3m), Max.20m

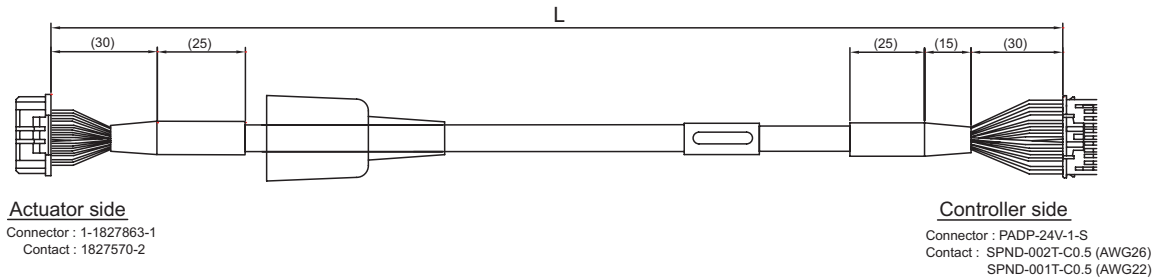

Connection diagram

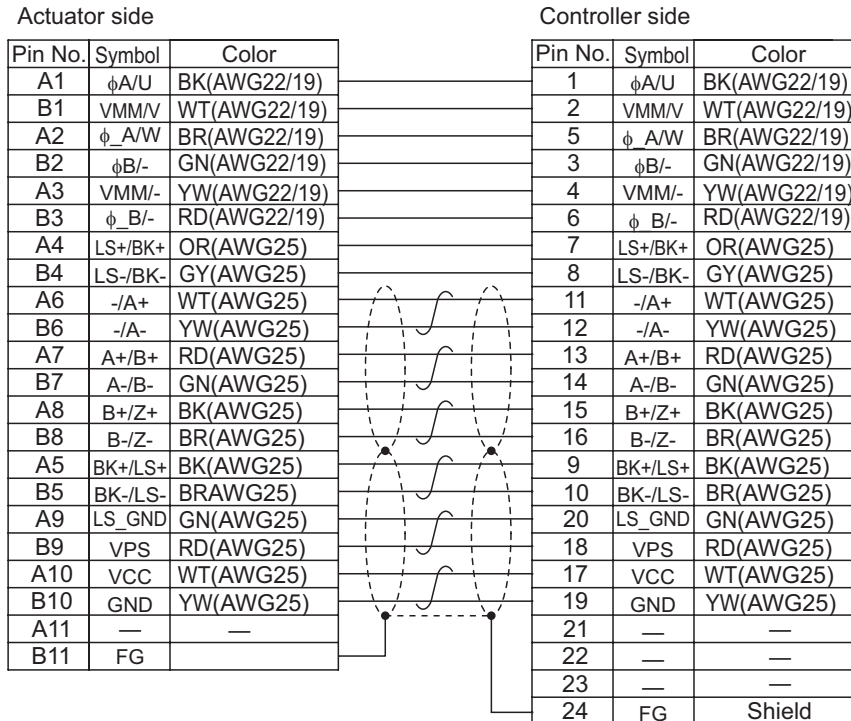

1.4.2 Cable for PCON-CA Controllers

[1] Motor • Encoder Integrated Cables

CB-CFA2-MPA□□□ (□□□ indicates the cable length (L) Example: 020=2m), up to 20m

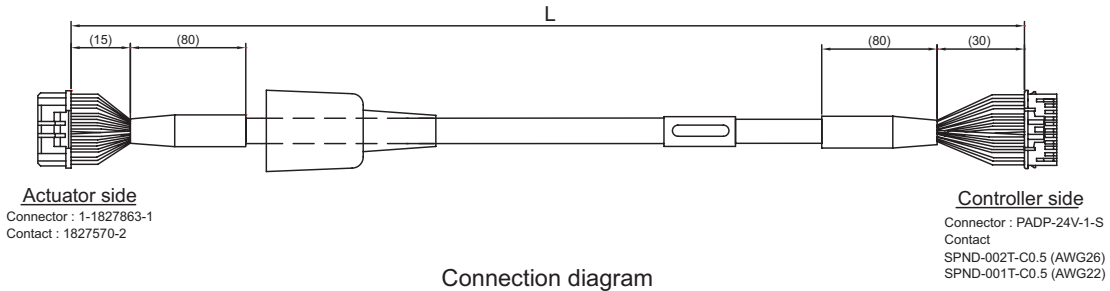

Actuator side
 Connector : 1-1827863-1
 Contact : 1827570-2

Controller side
 Connector : PADP-24V-1-S
 Contact
 SPND-002T-C0.5 (AWG26)
 SPND-001T-C0.5 (AWG22)

Actuator side				Controller side			
Thickness	Electric Wire Color	Symbol	Pin No.	Pin No.	Symbol	Electric Wire Color	Thickness
AWG22/19	BL	ϕ A	A1	1	ϕ A	BL	AWG22/19
AWG22/19	OR	VMM	B1	2	VMM	OR	AWG22/19
AWG22/19	GN	ϕ A	A2	5	ϕ A	GN	AWG22/19
AWG22/19	BR	ϕ B	B2	3	ϕ B	BR	AWG22/19
AWG22/19	GY	VMM	A3	4	VMM	GY	AWG22/19
AWG22/19	RD	ϕ B	B3	6	ϕ B	RD	AWG22/19
AWG26	BK	LS+	A4	7	LS+	BK	AWG26
AWG26	YW	LS-	B4	8	LS-	YW	AWG26
—	—	—	A6	11	—	—	—
—	—	—	B6	12	—	—	—
AWG26	GN	A+	A7	13	A+	GN	AWG26
AWG26	BR	A-	B7	14	A-	BR	AWG26
AWG26	GY	B+	A8	15	B+	GY	AWG26
AWG26	RD	B-	B8	16	B-	RD	AWG26
AWG26	BL	BK+	A5	9	BK+	BL	AWG26
AWG26	OR	BK-	B5	10	BK-	OR	AWG26
AWG26	GN	LS_GND	A9	20	LS_GND	GN	AWG26
AWG26	BR	VPS	B9	18	VPS	BR	AWG26
AWG26	GY	VCC	A10	21	VCC	GY	AWG26
AWG26	RD	GND	B10	19	GND	RD	AWG26
—	—	—	A11	17	—	—	—
—	BK	FG	B11	22	—	—	—
				23	—	—	—
				24	FG	BK	—

[2] Motor • Encoder Integrated Cables Robot Type

CB-CFA2-MPA□□□-RB (□□□ indicates the cable length (L) Example: 020=2m), up to 20m

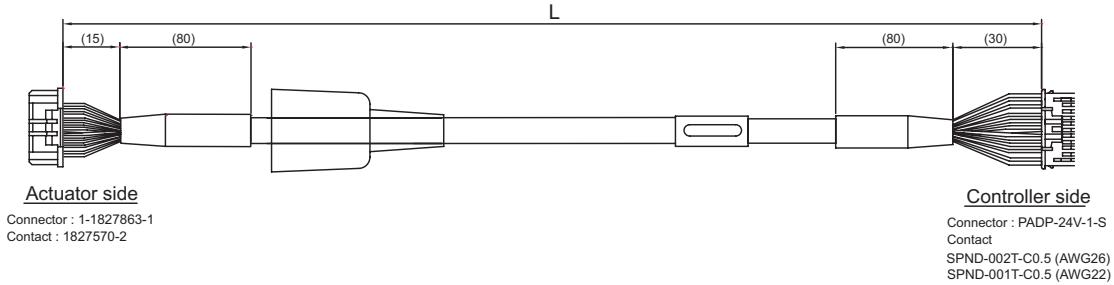

Connection diagram

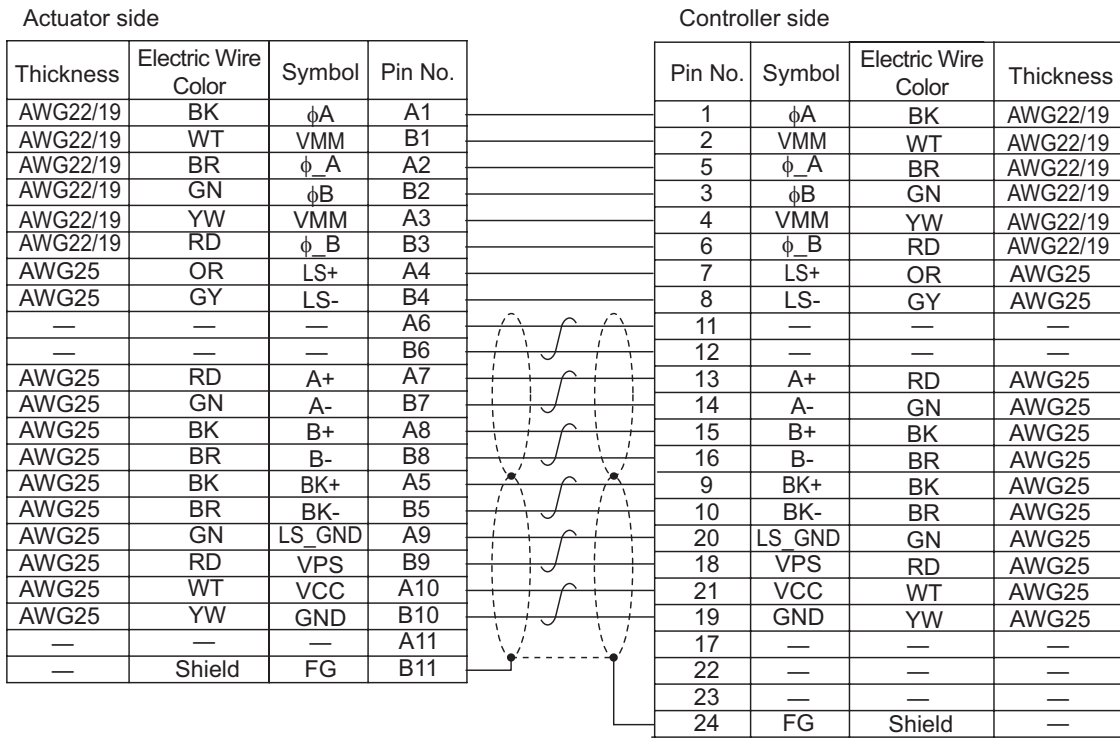

2. Installation

2.1 Transportation

[1] Handling of Robot

(1) Handling the Packed Unit

Unless otherwise specified, the actuator is shipped with each axis packaged separately.

- Do not damage or drop. The package is not applied with any special treatment that enables it to resist an impact caused by a drop or crash.
- Transport a heavy package with at least more than two operators. Consider an appropriate method for transportation.
- Keep the unit in horizontal orientation when placing it on the ground or transporting. Follow the instruction if there is any for the packaging condition.
- Do not step or sit on the package.
- Do not put any load that may cause a deformation or breakage of the package.

(2) Handling the Actuator After Unpacking

- Do not carry an actuator by motor unit and a cable or attempt to move it by pulling the cable.

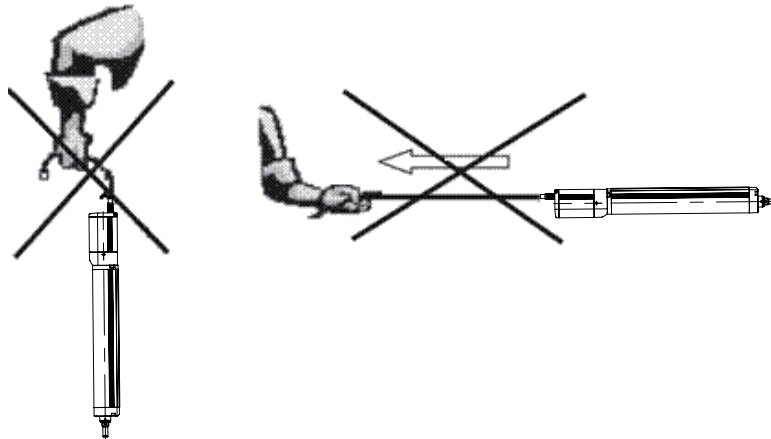

- Hold the body base when transporting the actuator.
- Be careful not to bump the actuator into anything when moving it.
- Do not apply an excessive force to each part of the actuator. In particular, prevent the motor unit and rear bracket from receiving an unnecessary force.

Supplement) For the names of each part of the actuator, refer to “Names of the Parts”

[2] Handling in Assembled Condition

- When carrying the actuator, exercise caution not to bump it against nearby objects or structures.
- Secure the rods to prevent sudden movement during transport.
- If any end of the actuator is overhanging, secure it properly to avoid significant movement due to external vibration.
- When transporting the assembly without the ends of the actuators fastened, do not subject the assembly to an impact of 0.3 G or more.
- When suspending the mechanical equipment (system) with ropes, avoid applying force to actuator, connector box, etc. Also, avoid the cables being pinched or caused an excessive deformation.

2.2 Installation and Storage • Preservation Environment

[1] Installation Environment

The actuator should be installed in a location other than those specified below.

In general, the installation environment should be one in which an operator can work without protective gear. Also provide sufficient work space required for maintenance inspection.

- Where the actuator receives radiant heat from strong heat sources such as heat treatment furnaces
- Where the ambient temperature exceeds the range of 0 to 40°C
- Where the temperature changes rapidly and condensation occurs
- Where the relative humidity exceeds 85% RH
- Where the actuator receives direct sunlight
- Where the actuator is exposed to corrosive or combustible gases
- Where the ambient air contains a large amount of powder dust, salt or iron (at level exceeding what is normally expected in an assembly plant)
- Where the actuator is subject to splashed water, oil (including oil mist or cutting fluid) or chemical solutions
- Where the actuator receives impact or vibration

If the actuator is used in any of the following locations, provide sufficient shielding measures:

- Where noise generates due to static electricity, etc.
- Where the actuator is subject to a strong electric or magnetic field
- Where the actuator is subject to ultraviolet ray or radiation

[2] Storage • Preservation Environment

- The storage and preservation environment should comply with the same standards as those for the installation environment. In particular, when the machine is to be stored for a long time, pay close attention to environmental conditions so that no dew condensation forms.
- Unless specially specified, moisture absorbency protection is not included in the package when the machine is delivered. In the case that the machine is to be stored and preserved in an environment where dew condensation is anticipated, take the condensation preventive measures from outside of the entire package, or directly after opening the package.
- For storage and preservation temperature, the machine withstands temperatures up to 60°C for a short time, but in the case of the storage and preservation period of 1 month or more, control the temperature to 50°C or less.
- Storage and preservation should be performed in the horizontal condition. In the case it is stored in the packaged condition, follow the posture instruction if any displayed on the package.

2.3 How to Installation

This chapter explains how to install the actuator on your mechanical system.

2.3.1 General Rules on Installation

Follow the information below when installing the actuator, as a rule. Do pay attention to these items (except with custom-order models).

○ : Possible △ : Daily inspection is required × : Not possible

Model	Horizontal installation	Vertical installation	Sideway installation	Ceiling mount installation
RA5C, RA6C RA5R, RA6R	○	○	○	○

(Note) The motor types 42SP and 56SP are the models dedicated for vertical orientation. They are equipped with a brake in standard.

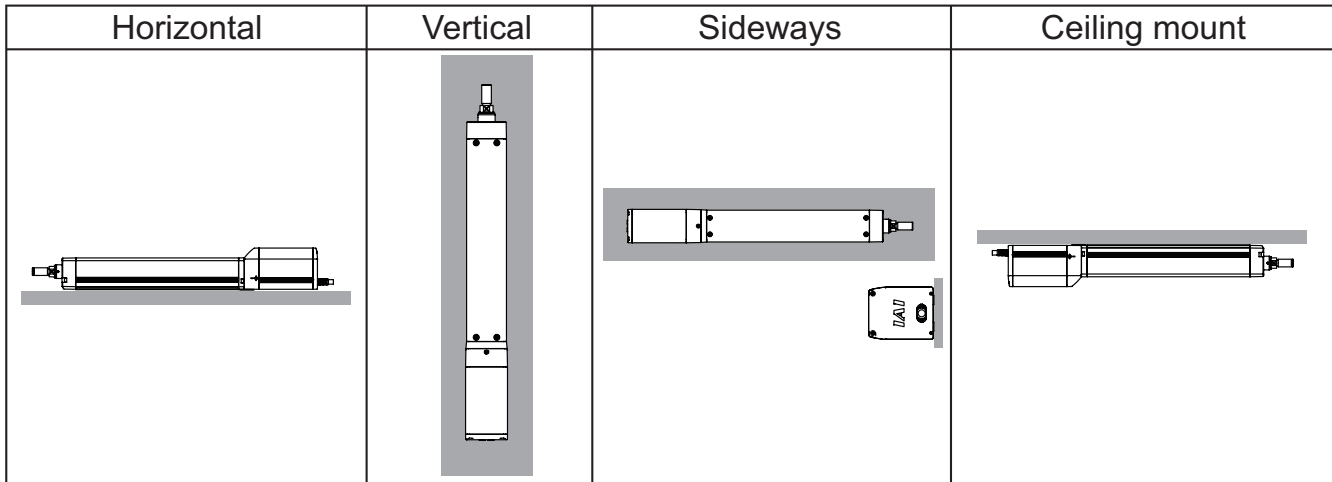

Caution: When the unit is installed vertically oriented, attempt to put the motor up unless there is a special reason. Putting the motor on the lower side would not cause a problem in an ordinary operation. However, it may rarely cause a problem, when it is not operated for a long period, depending on the surrounding environment (especially high temperature), caused by the grease being separated and the base oil flowing into the motor unit.

2.3.2 Installation of Main Unit

The surface to mount the main unit should be a machined surface or a plane that possesses an equivalent accuracy and the flatness should be within 0.05mm. Also, the platform should have a structure stiff enough to install the unit so it would not generate vibration or other abnormality.

Also consider enough space necessary for maintenance work such as actuator replacement and inspection. On the base there is a datum surface prepared for the attachment slotted holes.

On the back side of the actuator, there are attachment tapped holes, through holes, positioning reamed holes and slotted holes. For the details of the positions and dimensions, check in the appearance drawings. [Refer to 6. External Dimensions.]

When repeatability in re-attaching is required after it is detached, utilize the reamed holes. Please note, however, that a consideration is necessary such as to use only one point on the motor side of the reamed holes when a fine-tuning such as perpendicularity is required.

[1] Using the Tapped Holes on the Bottom of the Base

This actuator has tapped holes for mounting so it can be fixed from the bottom of the base.

(Note that the tapped hole size depends on the model. Please see the diagrams below and 6. "External Dimensions.")

Also, there are reamed holes and a slotted hole for positioning pins.

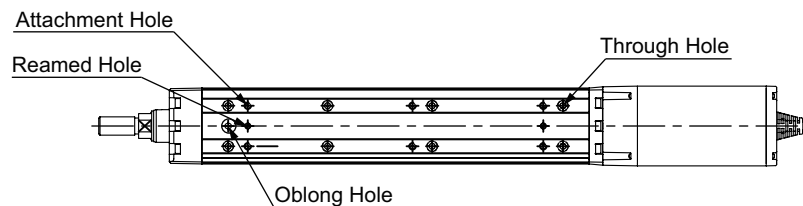

Model Name	Tapped Hole Size	Tapped Holes Depth	Tightening Torque		Reamer Hole [mm]
			In the case that steel is used for the bolt seating surface:	In the case that aluminum is used for the bolt seating surface:	
RA5C RA5R	M4	7mm	3.59N·m (0.37kgf·m)	1.76N·m (0.18kgf·m)	φ4H7 Depth 5.5
RA6C RA6R	M5	9mm	7.27N·m (0.74kgf·m)	3.42N·m (0.35kgf·m)	φ4H7 Depth 5.5

Tightening screws

- Use hexagonal socket head bolts for the male threads for installing the base.
- Use of high-tension bolts meeting at least ISO 10.9 is recommended.
- The length of thread engagement should be 1.8 times more than the nominal diameter, and pay attention not to stick the screw out inside the actuator.

⚠ Caution: Be careful when selecting the bolt length. If bolts of inappropriate lengths are used, the tapped holes may be damaged, actuator mounting strength may become insufficient, or contact with driving parts may occur, resulting in lower precision or unexpected accidents.

[2] Using the Mounting Holes on the Top of the Base

There are through holes equipped on the base so the unit can be attached from the top of the base. Detach the side covers on both sides when installing. (Remove 4 hex socket head cap screws.)

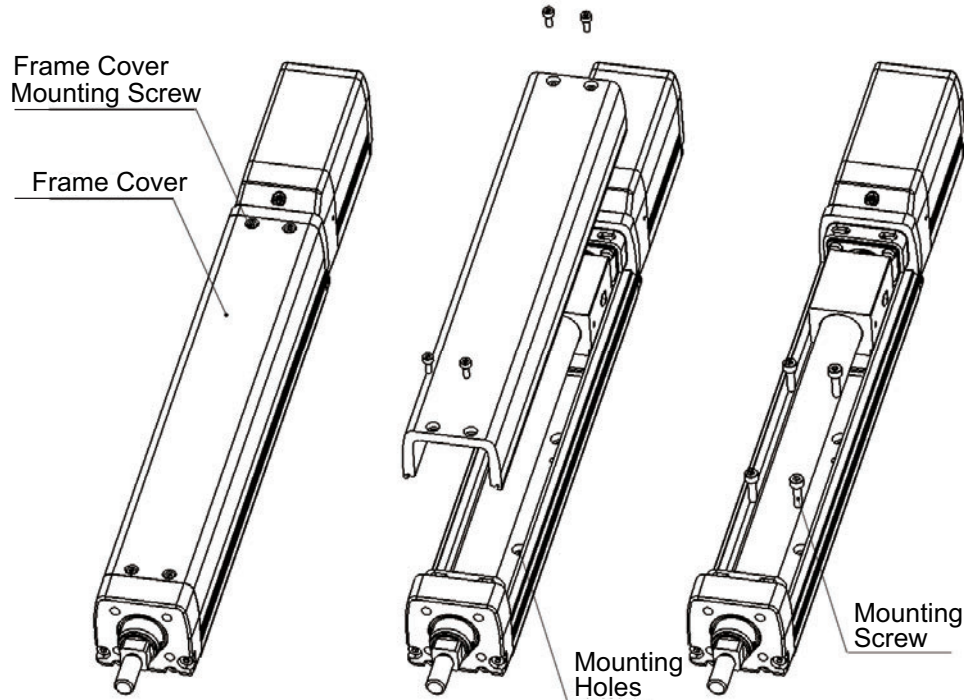

When affixing the frame cover, tighten the screws with the tightening torque described below.

Model Name	Screw Diameter	Tightening Torque
RA5C RA5R	M3	0.89N·m (0.9kgf·m)
RA6C RA6R	M4	2.07N·m (0.21kgf·m)

Apply the socket head cap screw indicated in the table below suitable for the platform material.

Model Name	Through Holes	Mounting Screw	Tightening Torque
RA5C RA5R	φ4.5 drilled hole, φ8 counter boring depth 4.5	M4	1.76N·m (0.18kgf·m)
RA6C RA6R	φ4.5 drilled hole, φ8 counter boring depth 4.5	M4	1.76N·m (0.18kgf·m)

Tightening screws

- Use hexagonal socket head bolts for the male threads for installing the base.
- Use of high-tension bolts meeting at least ISO 10.9 is recommended.
- For the effective engagement length between the bolt and female thread, provide at least the applicable value specified below:

Female thread is made of steel material → Same length as the nominal diameter

Female thread is made of aluminum → 1.8 times of nominal diameter

⚠ Caution: Pay attention when choosing the screw length. In case that insufficient length of screws is chosen, it may cause such problems as the strength not being enough on the actuator attachment, interference with driving part, drop in accuracy performance and unexpected accidents.

[3] When using Tapped Holes on Front Housing

There are tapped holes equipped on the front housing.
Utilize these tapped holes for installation.
The effective depth for the attachment screws is as shown below;

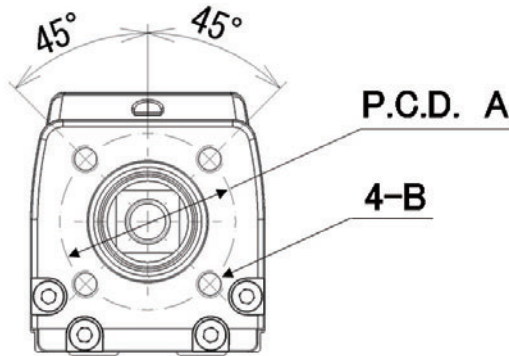

Model Name	Tapped Hole Size B	A	Screw Effective Depth	Tightening Torque	
				In the case that steel is used for the bolt seating surface:	In the case that aluminum is used for the bolt seating surface:
RA5C RA5R	M6	39	12	12.3N·m (1.26kgf·m)	5.4N·m (0.55kgf·m)
RA6C RA6R	M8	43	16	30N·m (3.1kgf·m)	11.5N·m (1.2kgf·m)

Make sure to follow “[6] Caution for Installation using Front Housing and Front Flange”

Tightening screws

- Use hexagonal socket head bolts for the male threads for installing the base.
- Use of high-tension bolts meeting at least ISO 10.9 is recommended.
- Have the length of thread engagement approximately 1.8 times of the nominal diameter.



Caution: Pay attention when choosing the screw length. In case that insufficient length of screws is chosen, it may cause such problems as the strength not being enough on the actuator attachment, interference with driving part, drop in accuracy performance and unexpected accidents.

[4] When using Front Flange (Option)

There are holes for attachment on the front flange. Utilize these holes for the installation. The attachment holes are located as shown below;

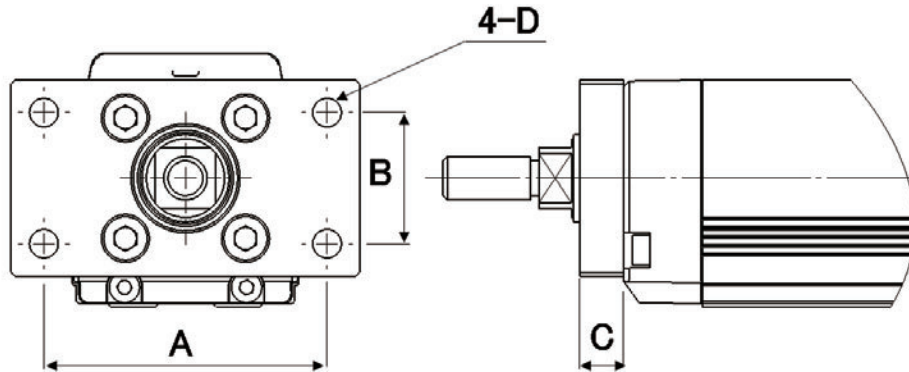

Model Name	Applicable Screw Diameter	A	B	C	D
RA5C/RA5R Front Flange	M6	65	30	10	φ6.6
RA6C/RA6R Front Flange	M8	76	33	12	φ9

Make sure to follow “[6] Caution for Installation using Front Housing and Front Flange”

Tightening screws

- Use hexagonal socket head bolts for the male threads for installing the base.
- Use of high-tension bolts meeting at least ISO 10.9 is recommended.
- For the effective engagement length between the bolt and female thread, provide at least the applicable value specified below:
 Female thread is made of steel material → Same length as the nominal diameter
 Female thread is made of aluminum → 1.8 times of nominal diameter

⚠ Caution: Pay attention when choosing the screw length. In case that insufficient length of screws is chosen, it may cause such problems as the strength not being enough on the actuator attachment, interference with driving part, drop in accuracy performance and unexpected accidents.

© Caution for Installation using Front Housing and Front Flange

Do not attempt to apply any external force to the body when installing with front housing or front flange (option). External force may cause an operation failure or parts malfunction.

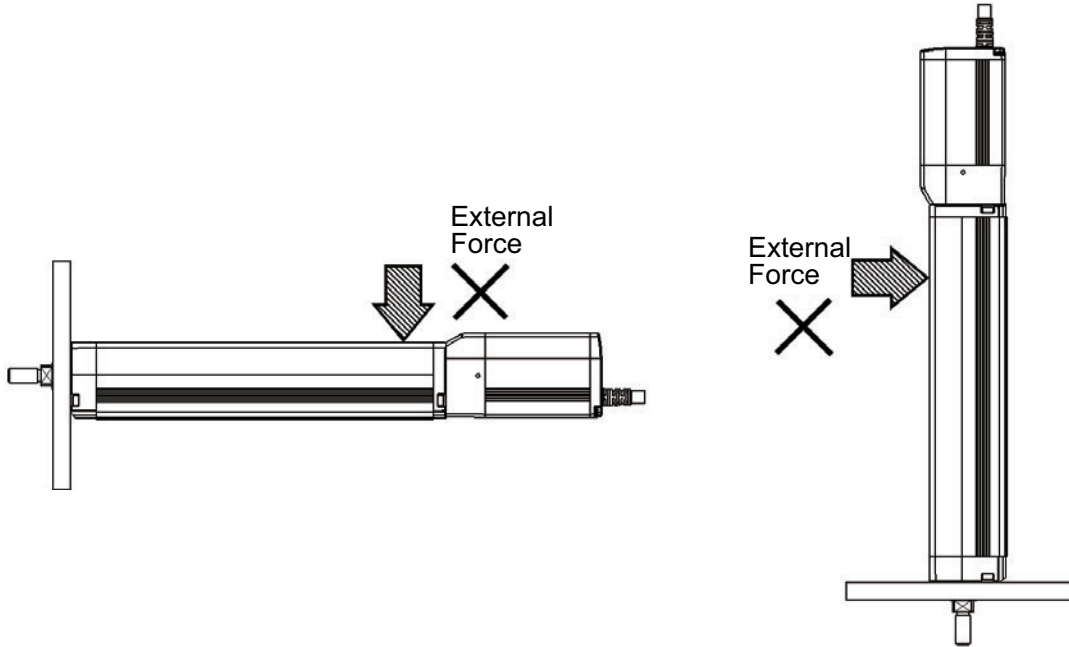

Prepare a support block as shown in the figure below for the horizontal installation of the unit with its stroke more than 150 even if there is no external force applied on the body. Even for those with the stroke less than 150, it is recommended to have a support block to avoid vibration being generated due to the operation condition or installation environment, which may cause an operation failure or parts malfunction.

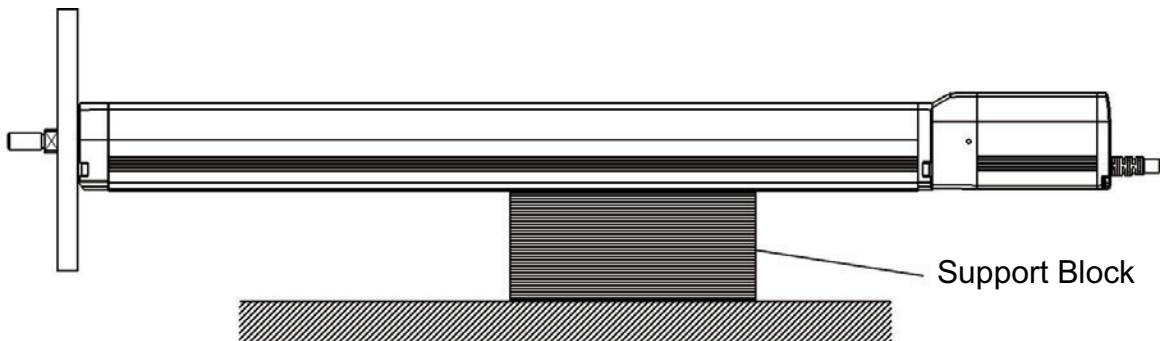

[5] When Utilizing Attachment Holes on the Bracket for Motor-Reversed Type

There are tapped holes prepared on the reversing bracket. (See the table below for the detailed dimensions.)

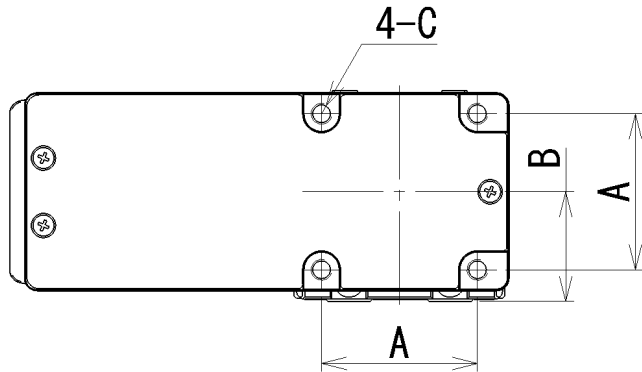

	A	B	C
RA5R	37	29.5	M5 Depth 15
RA6R	48	33	M6 Depth 14

Model Name	Attachment Holes	Attachment Hole Depth	Tightening Torque
RA5R	M5	15mm	3.42N·m (0.35kgf·m)
RA6R	M6	14mm	5.36 N·m (0.55kgf·m)

Tightening screws

- For attaching using male screw, use a hex socket cap screw.
- It is recommended to use high-tensile bolts with ISO-10.9 or more.
- Make sure to have the effective length of thread engagement at least approximately 1.8 times of the nominal diameter of bolts and screws.

Caution: Pay attention when choosing the screw length. In case that insufficient length of screws is chosen, it may cause such problems as the strength not being enough on the actuator attachment, interference with driving part, drop in accuracy performance and unexpected accidents.

[Precautions for Attachments]

Please note the following caution notes when installing the unit with using the tapped holes on the reversing bracket.

Do not attempt to affix the unit only with the tapped holes on the reversing bracket.

Do not apply external force to the main body.

There may be caused vibration due to the operating condition or installation environment, which may result in operational failures or components malfunction.

Availability of installation for each installation posture is as shown below:

(Note) When it is perpendicular installation without support etc., external force does not act, it is not attempt to apply the radial load.

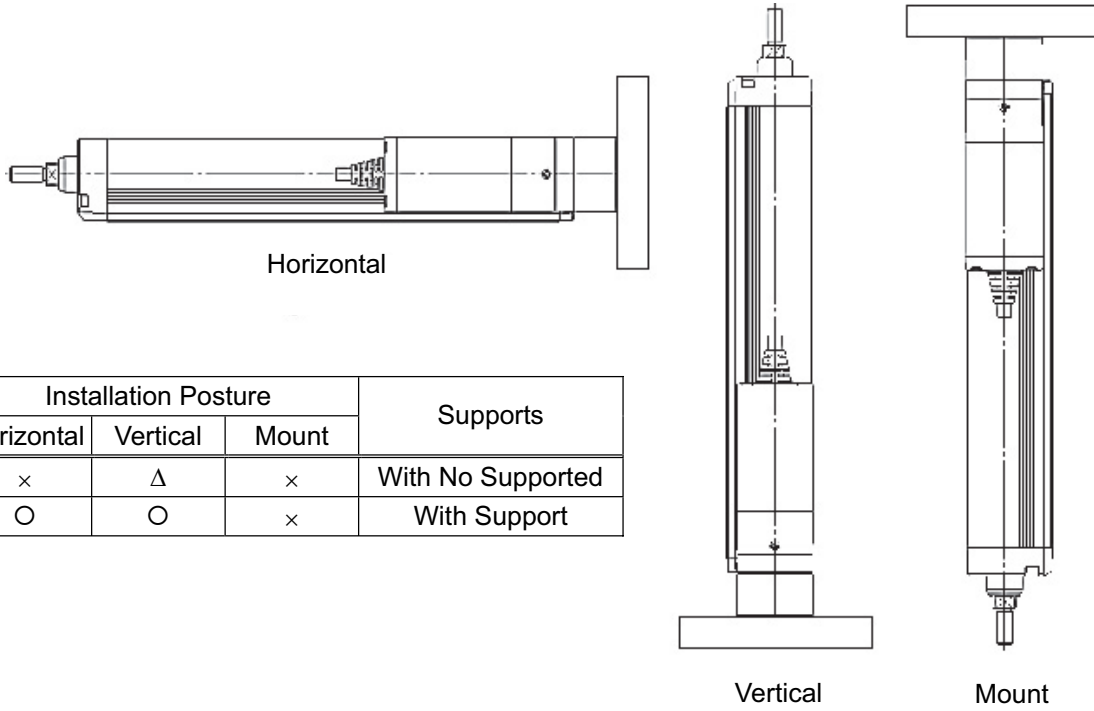

When using the unit in the horizontal or vertical orientation, have a pedestal to support the body to avoid external force being applied to the unit.

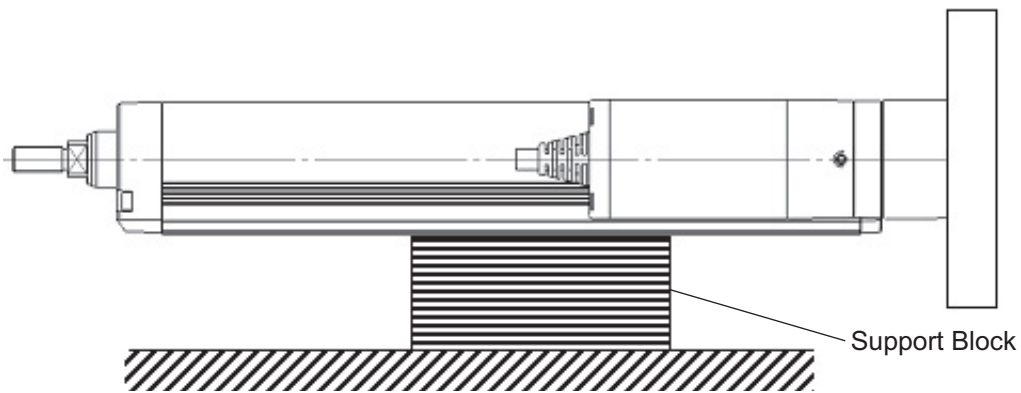

[6] Attachment of Work Part (Transported Object)

Utilize the threaded part on the rod tip to attach the work part (transported object). In the installation process, make sure to hold 2 faces on the tip with a wrench so the tightening torque would not be applied to the rod.

[7] Mounting Surface

- The platform to install the actuator should possess a structure that ensures enough stiffness, and should be free from vibration.
- The surface where the actuator will be mounted should be a machined surface or that with an accuracy equivalent to it, and the flatness should be 0.05mm/m or below.
- Ensure a room for maintenance work.
- The side and bottom surfaces of the base on the actuator work as the datum surfaces for the side of the rod.
- Use these surfaces as the datum surfaces for mounting.

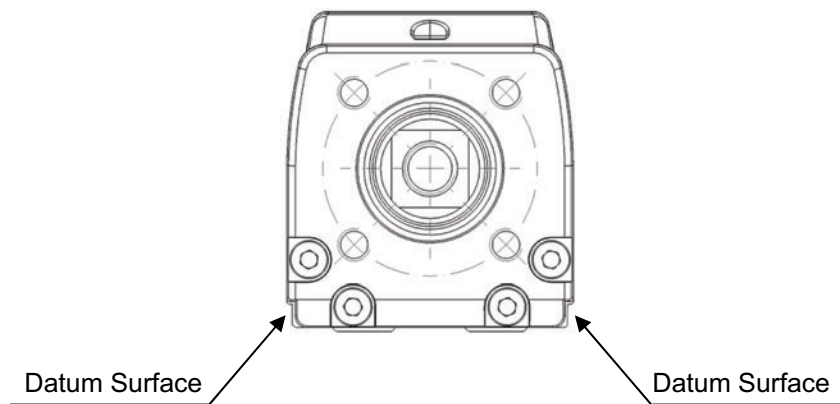

Follow the diagram below when installing the device using the reference surface.

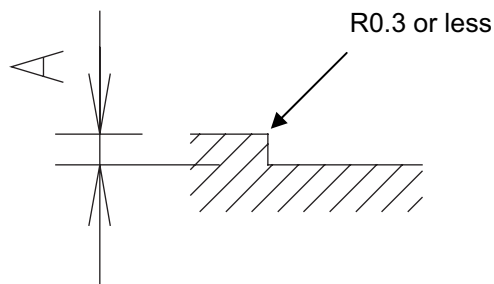

Model Name	A Dimensions [mm]
RA5/6	2 to 4 or less

3. Connecting with Controller

As the connection cable for the controller and RCP4 (this actuator), use the IAI-dedicated controller and dedicated connection cable.

This section explains the wiring method for a single axis.

- If the dedicated connection cable cannot be secured, reduce the load on the cable by allowing it to deflect only by the weight of the cable or wire it in a self-standing cable hose, etc., having a large radius.
- Do not cut and reconnect the dedicated connection cable for extension or shorten the cable.
- Do not pull on the dedicated connection cable or bend it forcibly.
- The actuator cable coming out of the motor unit is not meant to be bent. Fix the cable so it would not be bent repeatedly.

Please consult with IAI if you require a different kind of cable than the one supplied.

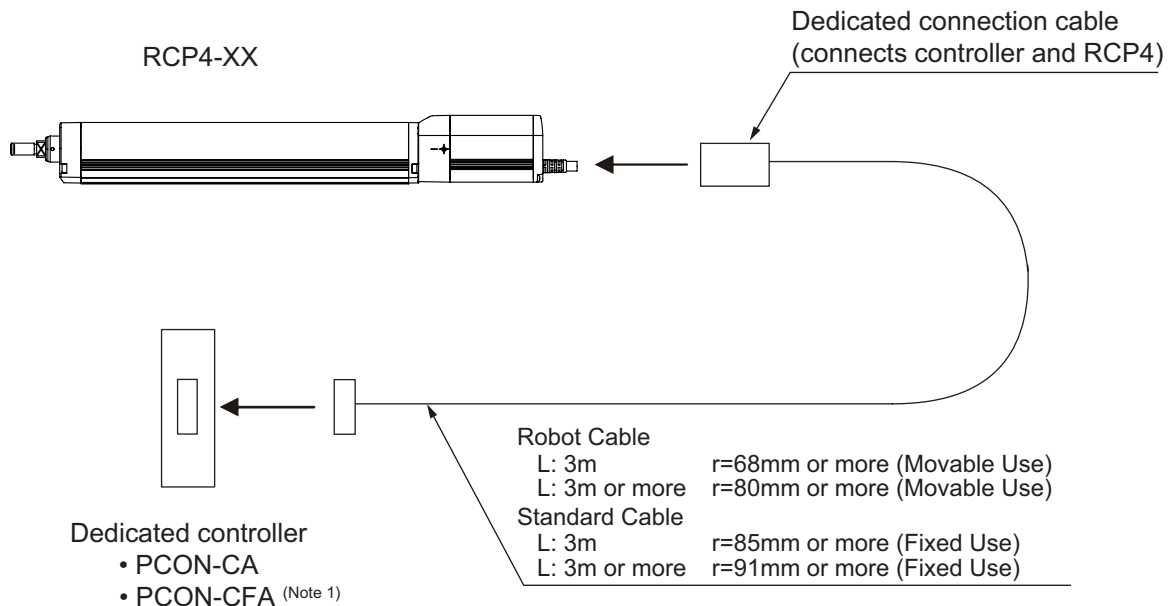

Dedicated connection cable

[For PCON-CA]

Motor-encoder : CB-CA-MPA□□□

Motor-encoder robot cable : CB-CA-MPA□□□-RB

[For PCON-CFA]

Motor-encoder : CB-CFA2-MPA□□□

Motor-encoder robot cable : CB-CFA2-MPA□□□-RB

(Note) □□□ indicates the cable length. Up to 20m can be specified.

Example) 080=8m

Note 1 Only the motor type 56SP is applicable for PCON-CFA Controller.



Warning: For wiring, please follow the warnings stated below. When constructing a system as the machinery equipment, pay attention to the wiring and connection of each cable so they are conducted properly. Not following them may cause not only a malfunction such as cable breakage or connection failure, or an operation error, but also electric shock or electric leakage, or may even cause a fire.

- Use dedicated cables of IAI indicated in this instruction manual. Contact us if you wish to have a change to the specifications of the dedicated cables.
- Make sure to turn the power off in the process of power line or cable connection or disconnection.
- Do not attempt to cut a dedicated cable with connectors on both ends to extend, shorten or re-joint it.
- Hold the dedicated cable to avoid mechanical force being applied to the terminals and connectors.
- Use a cable pipe or duct to have an appropriate protection when there is a possibility of mechanical damage on a dedicated cable.
- In case a dedicated cable is to be used at a moving part, make sure to lay out the cable without applying any force to pull the connector or extreme bend on the cable. Do not attempt to use the cable with a bending radius below the allowable value.
- Make certain that the connectors are plugged properly. Insufficient connection may cause an operation error, thus it is extremely risky.
- Do not lay out the cables to where the machine runs over them.
- Pay attention to the cable layout so it would not hit peripherals during an operation. In case it does, have an appropriate protection such as a cable track.
- When a cable is used hanging on the ceiling, prevent an environment that the cable swings with acceleration or wind velocity.
- Make sure there is not too much friction inside the cable storage equipment.
- Do not apply radiated heat to power line or cables.
- Do not bend the cable in the area from the connector tip inward to 150mm on both ends.
Standard cable : CB-CA-MPA□□□, CB-CFA2-MPA□□□
Robot cable : CB-CA-MPA□□□-RB, CB-CFA2-MPA□□□-RB

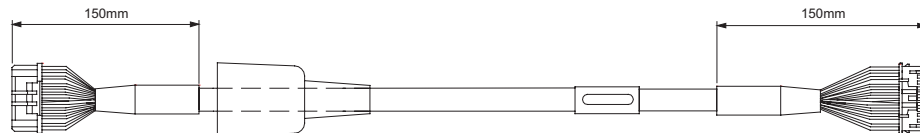

- Have a sufficient radius for bending, and avoid a bend concentrating on one point.

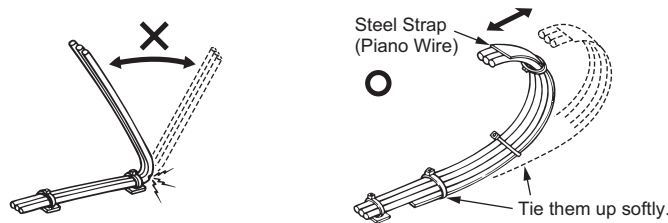

- Do not let the cable bend, kink or twist.

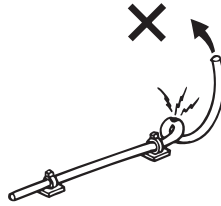

- Do not pull the cable with a strong force.

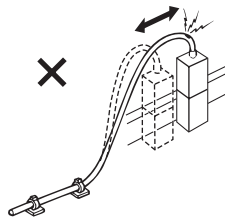

- Pay attention not to concentrate the twisting force to one point on a cable.

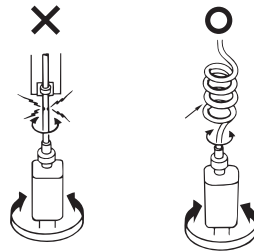

- Do not pinch, drop a heavy object onto or cut the cable.

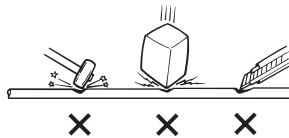

- When a cable is fastened to affix, make sure to have an appropriate force and do not tighten too much.

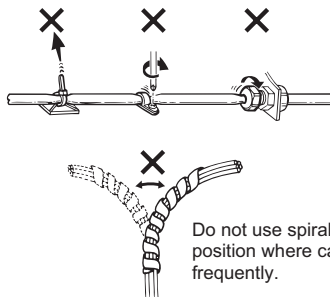

Do not use spiral tube in any position where cables are bent frequently.

- PIO line, communication line, power and driving lines are to be put separately from each other and do not tie them together. Arrange so that such lines are independently routed in the duct.

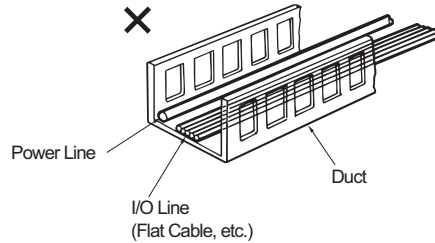

Follow the instructions below when using a cable track.

- If there is an indication to the cable for the space factor in a cable track, refer to the wiring instruction given by the supplier when storing the cable in the cable track.
- Avoid getting cables twined or twisted in the cable track, and also having the cables move freely and do not tie them up. (Avoid tension being applied when the cables are bent.) Do not pile up cables. It may cause faster abrasion of the sheaths or cable breakage.

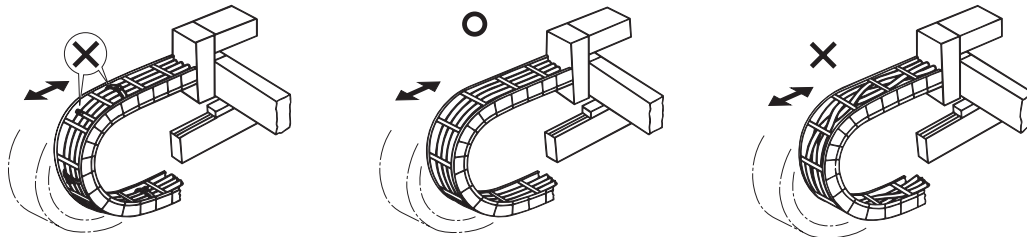

4. Caution for Operation

- When the reaction force against the pressing operation is the side-way force, make sure it would not exceed the allowable load.

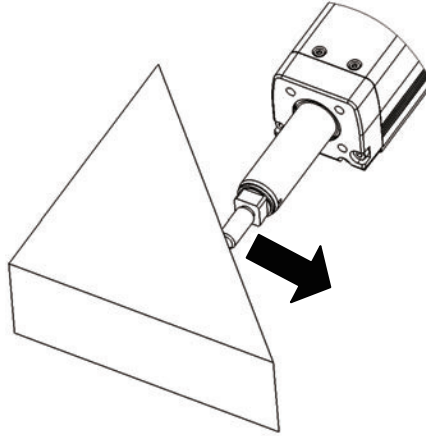

Be careful on the direction of the reaction force against the pressing operation.

- When connecting the rod to external guides, be careful on the parallelism of the guides to the rod. When connecting and fixing the rod to external guides, be careful not to apply excess side-way load to the rod because of the assembly variation. For the connection of the rod and guides, have a component such as a free joint to accept the assembly variation.

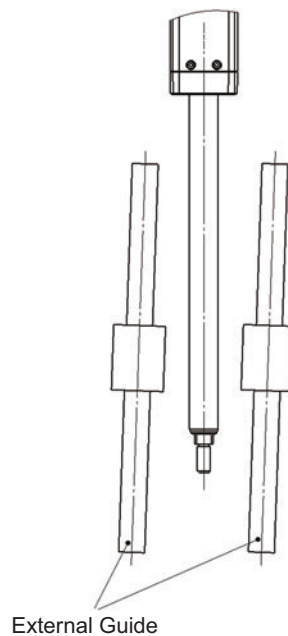

- When using a stroke of more than 200 and the load is eccentric (offset), the rod may generate vibration in some operation conditions. Apply guides to control the vibration.

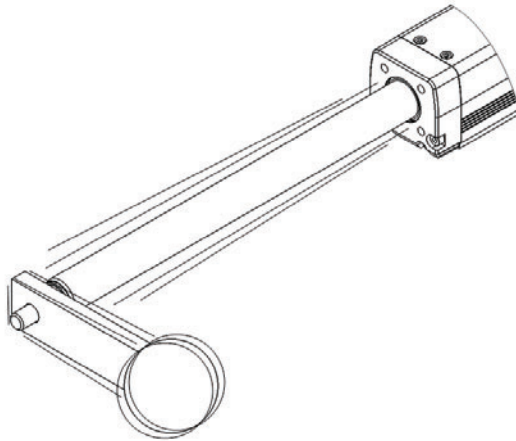

5. Maintenance Inspection

5.1 Inspection Items and Schedule

Follow the maintenance inspection schedule below.

It is assumed that the equipment is operating 8 hours per day.

If the equipment is running continuously night and day or otherwise running at a high operating rate, inspect more often as needed.

	External visual inspection	Internal inspection	Greasing
Start of work inspection	○		
1-month inspection	○		
3-month inspection	○		○ (Rod sliding surface)
Every 3 months since	○		○ (Rod sliding surface)
6-month inspection or every 5000km of operated distance	○	○	○(Ball Screw/Guide)
Every 1 year since	○	○	○(Ball Screw/Guide)

5.2 External Visual Inspection

An external visual inspection should check the following things.

Main unit	Loose actuator mounting bolts, other loose items
Rod	Lubrication, dust, foreign object on sliding surfaces
Scraper (optional equipment)	Damage, crack, scratch, wear-out
Cables	Scratches, proper connections
Overall	Irregular noise, vibration

* Scraper (optional equipment) is an expendable part. It may be shortened depending on the use environment or operating condition, thus replace the scraper as soon as an abnormality is found.

5.3 Cleaning

- Clean exterior surfaces as necessary.
- Use a soft cloth to wipe away dirt and buildup.
- Do not blow too hard with compressed air as it may cause dust to get in through the gaps.
- Do not use oil-based solvents as they can harm lacquered and painted surfaces.
- To remove severe buildup, wipe gently with a soft cloth soaked in a neutral detergent or alcohol.

5.4 Internal Inspections

Turn OFF the power, remove the side cover and have a visual inspection. When inspecting the interior, check the following items.

Main unit	Loose mounting bolts, other loose items
Guide section	Lubrication, buildup
Ball screw	Lubrication, buildup

Visually inspect the interior of the equipment. Check whether dust or other foreign matter has gotten inside and check the lubrication state.

The lubrication may have turned brown. This is not a problem as long as the travel surfaces shine as though they are wet.

If the grease is mixed with dust and does not have a shiny appearance, or if the grease has lost its efficacy due to prolonged use, then clean each section and reapply grease.

The procedure for internal inspections is outlined below.

- 1) With 2.5mm (RA5C, RA5R) or with 3mm (RA6C, RA6R) hex wrench, loosen the screws holding the frame cover, and detach the frame cover.
- 2) Check inside.
Extend the rod when checking the ball screw. The ball screw will appear. Slide the rod manually with hand or move it with JOG operation of the controller.
- 3) After finishing the inspection, assemble back in the reverse order.

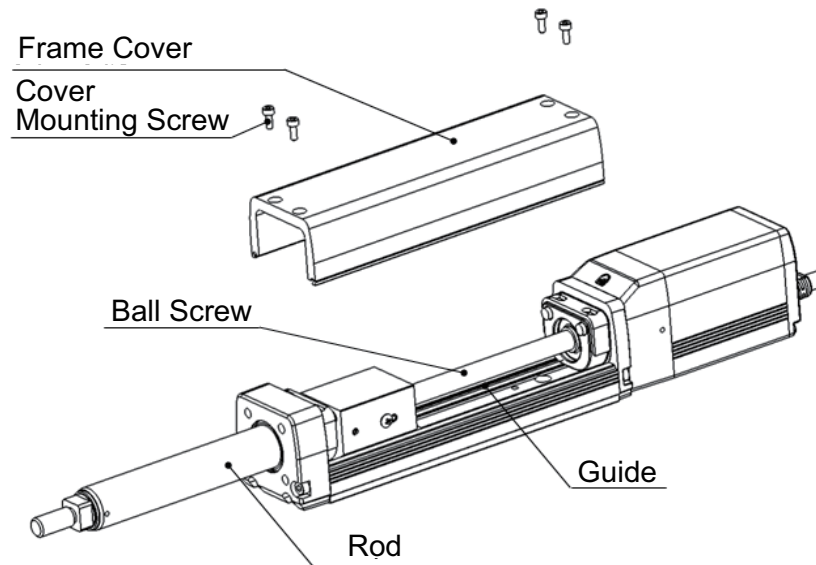

5.5 Internal Cleaning

- Use a soft cloth to wipe away dirt and buildup.
- Do not blow too hard with compressed air as it may cause dust to get in through the gaps.
- Do not use oil-based solvents, neutral detergent or alcohol.

5.6 Grease Supply

5.6.1 What Grease to Use on the Guides

IAI uses the following grease in our plant.

Guide	Idemitsu Kosan	Daphne Eponex Grease No. 2
-------	----------------	----------------------------

Other companies also sell similar types of grease. For details, give the above grease name to the manufacturer you want to purchase from and ask what corresponding product they have available. Here are some examples of similar products.

Showa Shell Oil	Albania Grease No. 2
Mobil Oil	Mobilax 2



Warning: Never use anything other than synthetic poly-olefin grease. Mixing poly-grease with other grease not only reduces the performance of the grease, it may even cause damage to the actuator.

5.6.2 What Grease to Use on the Ball Screw

IAI uses the following grease in our plant.

Ball Screw	Kyodo Yushi	Multitemp LRL 3
------------	-------------	-----------------



Warning: Never use anything other than synthetic poly-olefin grease. Mixing poly-grease with other grease not only reduces the performance of the grease, it may even cause damage to the actuator.

5.6.3 Grease to be applied on the Rod (Sliding Surface)

The following grease is applied when the product is shipped out from IAI factory.

Rod (sliding surface)	Kyodo Yushi	Multitemp LRL 3
-----------------------	-------------	-----------------

When supplying the grease, use the lithium-based all-around grease (consistency class: NLGI 2 to 0).



Caution: If the unit is equipped with the scraper (optional equipment), apply the grease on the rod sliding surface inside the main unit.
Even if the grease is applied on the rod sliding surface outside the main unit, the scraper sweeps out the grease, thus the grease would not be applied evenly throughout the whole area of the shaft holder or the sliding surface.

5.6.4 How to apply grease

- (1) With 2.5mm (RA5C, RA5R) or with 3mm (RA6C, RA6R) hex wrench, loosen the screws holding the frame cover, and detach the frame cover.

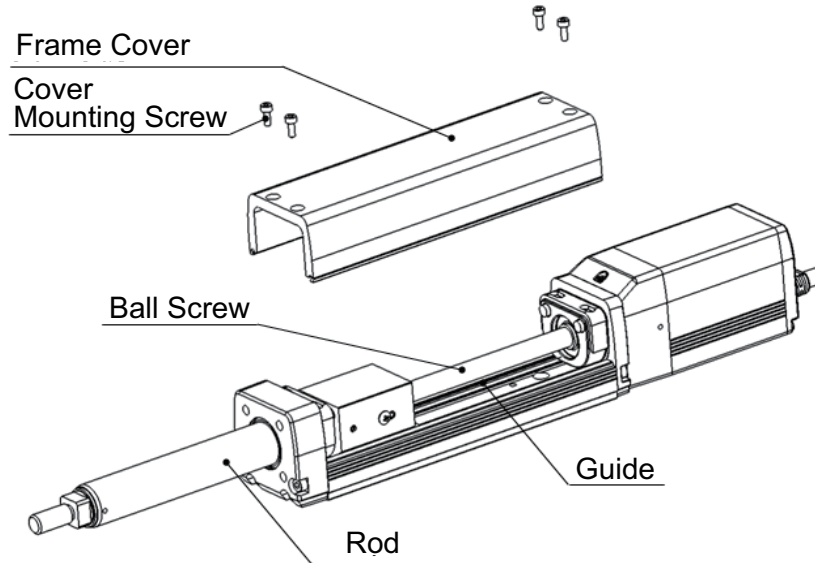

- (2) Pull out the rod. The ball screw will appear.
For some of the low lead actuators, the rod would not move manually with hand. Move it with JOG operation of the controller.

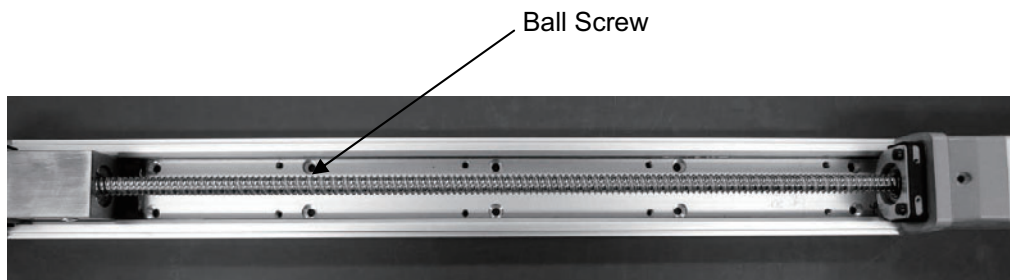
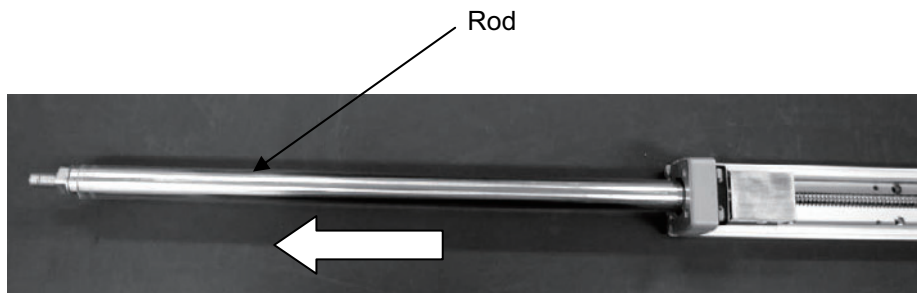

- (3) After cleaning up the guide on both sides, apply the grease. Slide the rod back and forth to evenly apply the grease. Wipe off the excess grease at last.

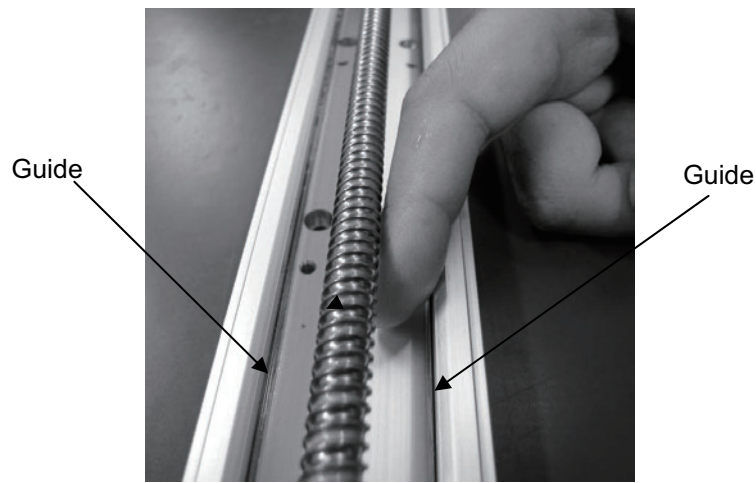

- (4) After cleaning up the ball screw, apply the grease with hand. Move the rod back and forth to evenly apply the grease. For some of the low lead actuators, the rod would not move manually with hand. Move it with JOG operation of the controller. Wipe off the excess grease at last.

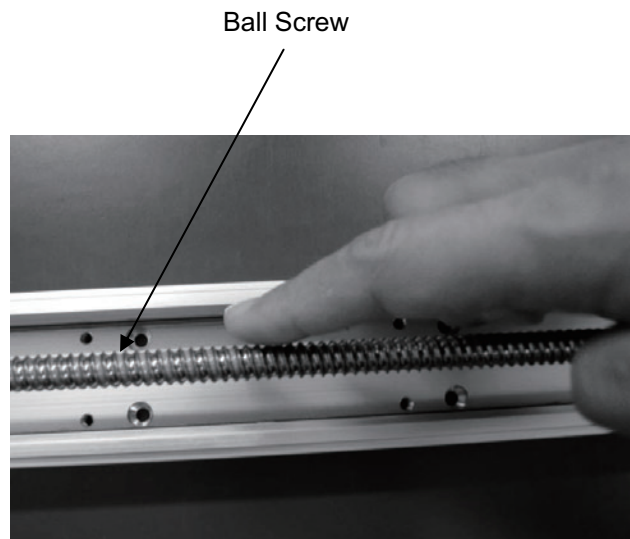

- (5) If the unit is not equipped with the scraper (option), clean up the rod (sliding surface) and apply the grease with hands.

Move the rod back and forth to evenly apply the grease.

For some of the low lead actuators, the rod would not move manually with hand.

Move it with JOG operation of the controller.

Wipe off the excess grease at last.

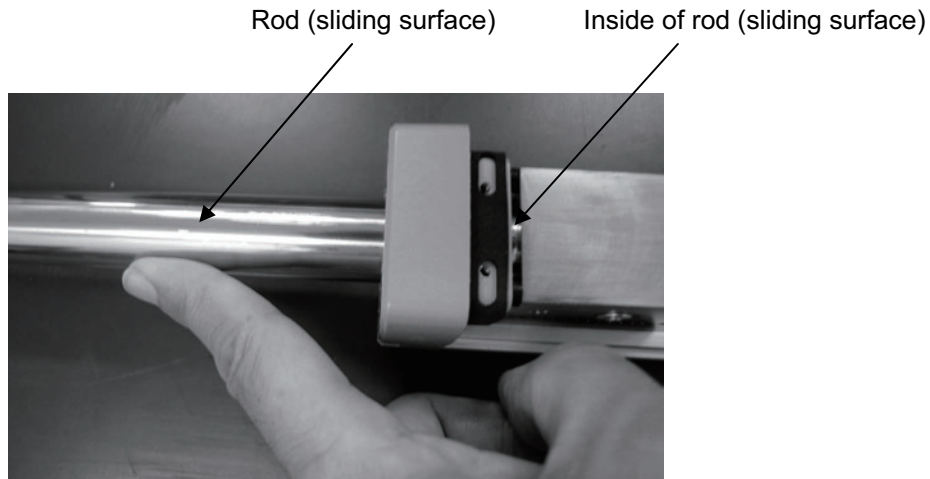

If the unit is equipped with the scraper (optional), apply the grease on the rod sliding surface inside the main unit.

Even if the grease is applied on the rod sliding surface outside the main unit, the scraper sweeps out the grease, thus the grease would not be applied evenly throughout the whole area of the shaft holder or the sliding surface.

- (6) After supplying the grease, attach the frame cover.



Caution: In case the grease got into your eye, immediately go see the doctor to get appropriate care.
After finishing the grease supply work, wash your hands carefully with water and soap to rinse the grease off.

5.7 Procedure for Belt Replacement and Tuning

Applicable Units : RCP4-RA5R, RA6R

5.7.1 Inspection of the Belt

For inspection work, detach the pulley cover with 1.5mm-sized hex wrench and carry it out by visual.

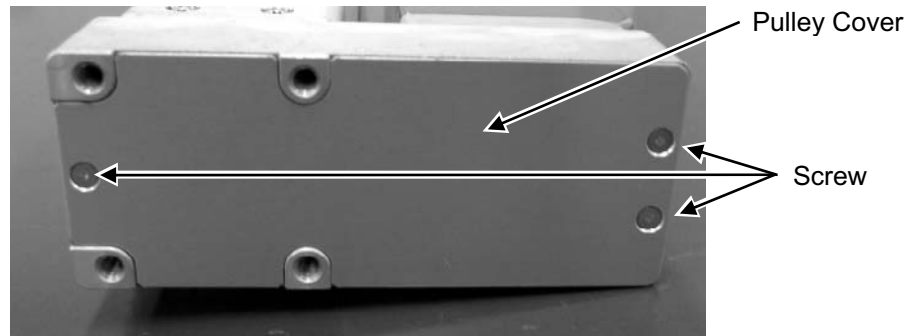

The replacement period cannot be determined in general because the durability of the deceleration belt can be greatly influenced by the conditions of operation.

It generally has life of hundreds of times for bending movement.

The timing belt requires replacement regularly under the following conditions as a reference since degradation such as abrasion proceeds as the time passes for usage.

- When remarkable abrasion is confirmed on the teeth or edges of the belt
- When the belt is swelled for such reasons as oil being attached on
- When damage is confirmed such as crack on the tooth or back of the belt

Also, since it is difficult to confirm the degradation of the core wires to retain the strength of the toothed belt by visual or looseness caused by being elongated, it is recommended to set regular replacement periods in advance in case the product is used under such conditions that gives the core wires great fatigue due to high acceleration and deceleration speed.

5.7.2 Belts to be used

The following belt is applied when the product is shipped out from IAI factory.

RA5R	• 60S2M196GB	Rubber	Bare back type (Mitsuboshi Belting Ltd.)
RA6R	• 100S3M237GB	Rubber	Bare back type (Mitsuboshi Belting Ltd.)

5.7.3 Replacement of the Belt

[Items Required for Replacemet Work]

- Belt for Replacement
- Hex wrench
1.5mm, 2.5mm (RA5R) or 3mm (RA6R) - sized
- Tension gauge (that is available for pulling with 80N)
- Long cable band (thin string)

[Procedures]

- 1) Remove the three screws holding the pulley cover with a 1.5mm-sized hex wrench to detach the pulley cover.

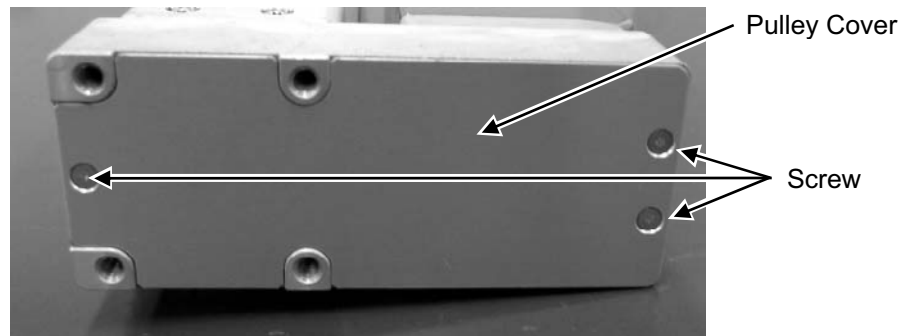

- 2) Loosen the four screws holding the pulley on the motor side with a 2.5mm-sized (RA5R) or 3mm-sized (RA6R) hex wrench.
If the belt is required to be replaced, replace it.

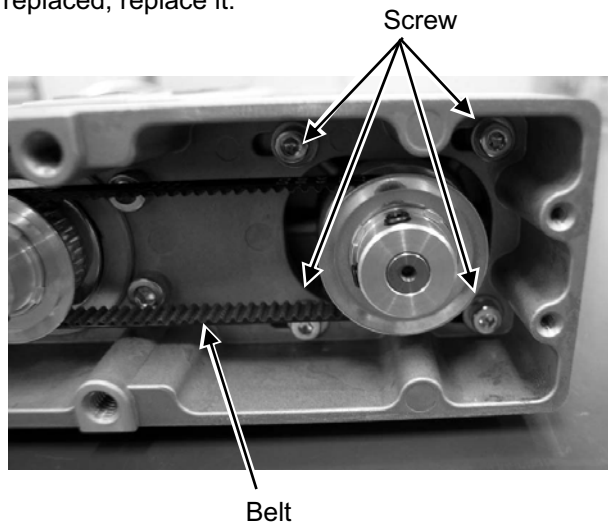

3) Adjust the belt tension.

Hand a cable band (thin string) on the edge of the motor unit and pull it on a tension gauge with the specified load (specified value of the belt tension).

When the load reached the specified, tighten the screws with a 2.5mm-sized (RA5R) or 3mm-sized (RA6R) hex wrench to hold the unit in the place.

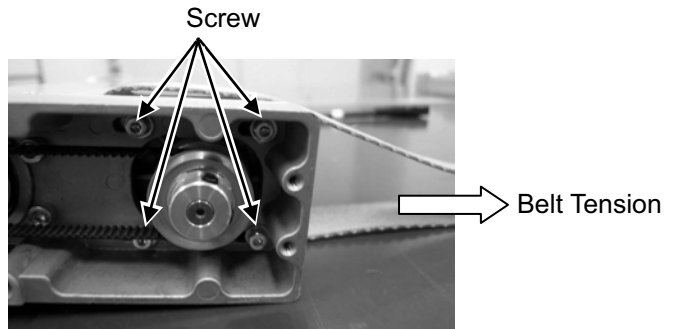
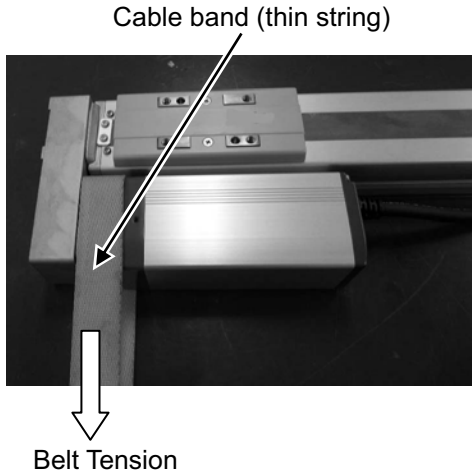

Belt Tension	
RA5R	25 to 30N
RA6R	80 to 90N
RA5R	Tightening Torque : 162 N • cm
RA6R	Tightening Torque : 323 N • cm

4) Tighten the three screws to hold the pulley cover with a 1.5mm-sized hex wrench to attach the pulley cover.

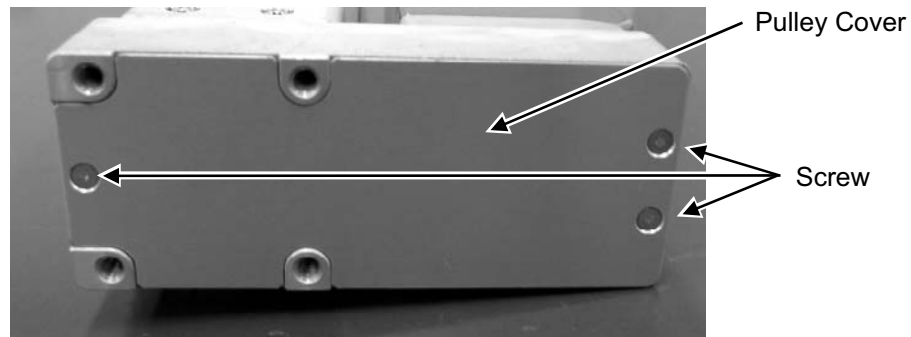

Tightening Torque : 25.4 N • cm

5.8 Motor Replacement Process

5.8.1 RCP4-RA5C, RA6C

[Items required for replacing the motor]

- Motor Unit for Replacement
- Hex wrench set
3mm-sized

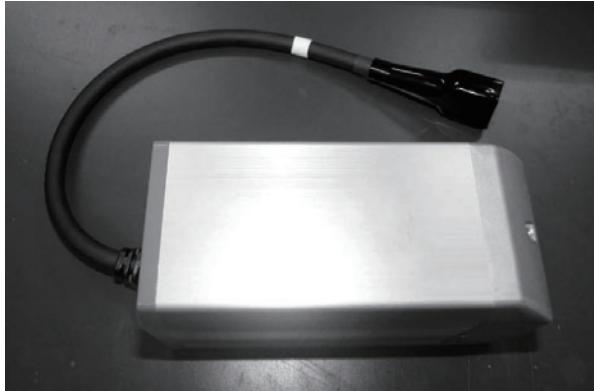

[Procedure]

- 1) Remove the screw affixing the actuator and the motor unit with a 3mm hex wrench.

For Fixed screws actuator and Motor Unit

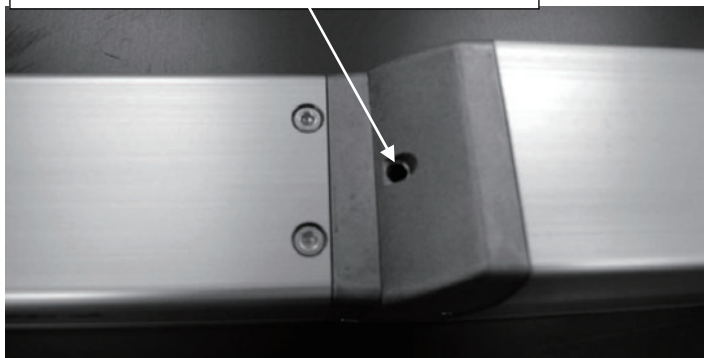

- 2) Detach the motor unit.

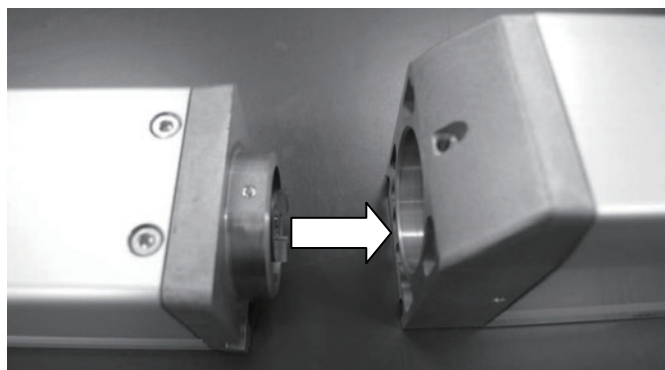

3) Make the profiles on the actuator side and motor unit side aligned so the projection matches to the slit.

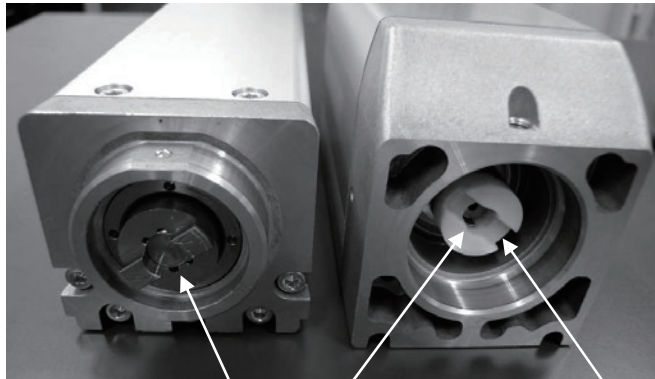

Make the projection and slit matched with each other.

Apply grease to the coupling part.
TL101Y grease made by NOK

4) Attach the motor unit for replacement with the projection being matched with the slit.

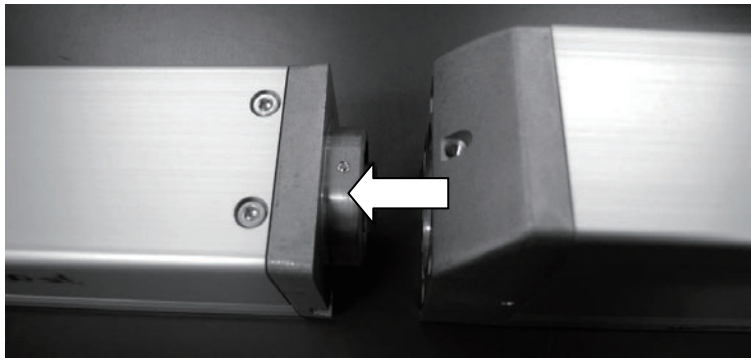

5) Tighten the screw to affix the motor unit to the actuator with 3mm hex wrench.

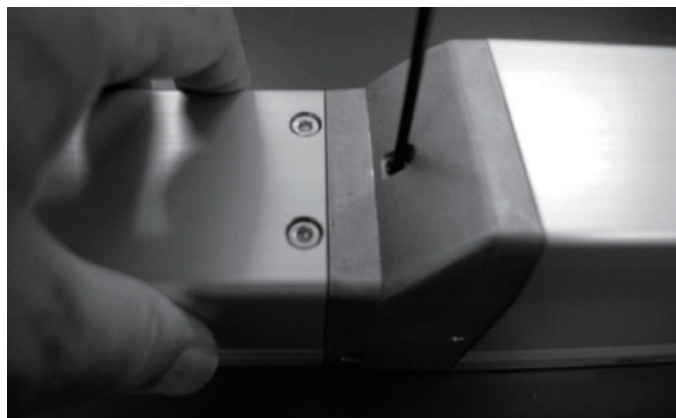

Tightening Torque : 350 N • cm

5.8.2 RCP4-RA5R, SA6R

[Items Required for Replacement Work]

- Motor Unit for Replacement
- Hex Wrench Set
3mm-sized



[Procedure]

- 1) Remove the screw affixing the actuator and the motor unit with a 3mm hex wrench.

Fixing screw for actuator and motor unit

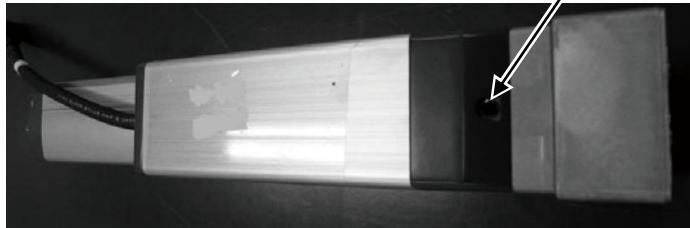

- 2) Detach the motor unit.

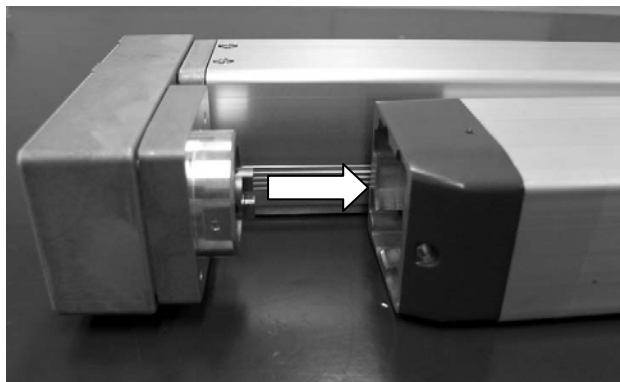

3) Make the profiles on the actuator side and motor unit side aligned so the projection matches to the slit.

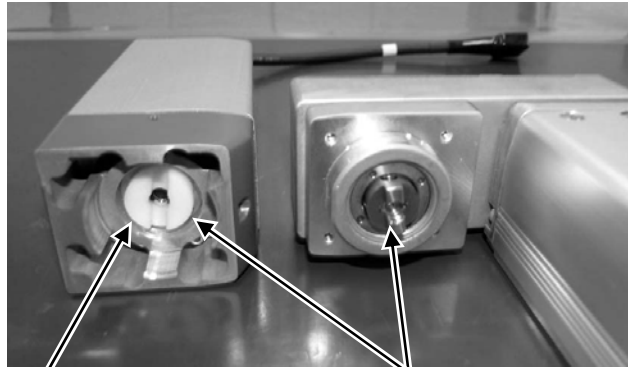

Apply grease to the coupling part.
TL101Y grease made by NOK

Make the projection and slit matched
with each other.

4) Attach the motor unit for replacement with the projection being matched with the slit.

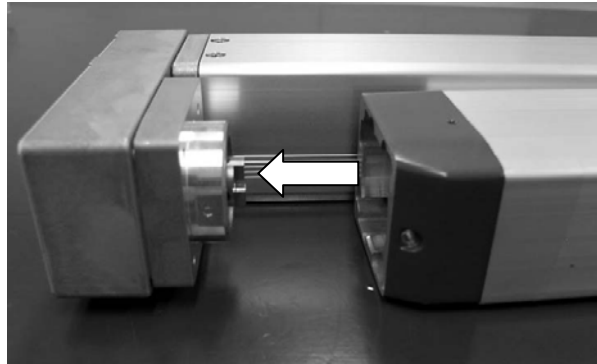

5) Tighten the screw to affix the motor unit to the actuator with 3mm hex wrench.

Fixing screw for actuator and motor unit

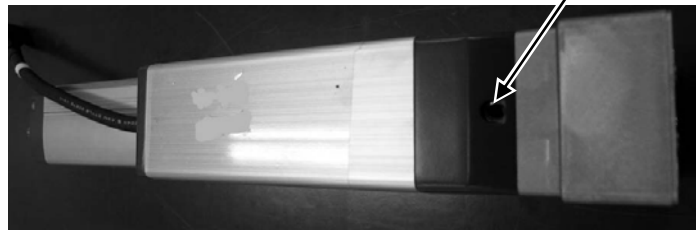

Tightening Torque : 350 N • cm

5.9 Procedure to Replace Scraper (Option)

[Items required for replacing the motor]

- Hex wrench set
- Replacement Scraper

Model Name	Model No.	Supplier
RA5C, RA5R	SFR-22K	Sakagami Seisakusho, Ltd.
RA6C, RA6R	SFR-25K	Sakagami Seisakusho, Ltd.

- 1) Remove the actuator from the device temporarily, and place it on the work bench horizontally to ensure the safety.
Working with it in vertical orientation has a risk of the rod dropping down. Never attempt to do so.
- 2) Detach the frame cover with a 2.5mm (RA5C, RA5R) or 3mm (RA6C, RA6R) hex wrench.
Detach the front housing with a 3mm hex wrench. Be careful not to extend the rod. In the case the rod is extended and pulled out of the main body, it would not be put back to the unit.

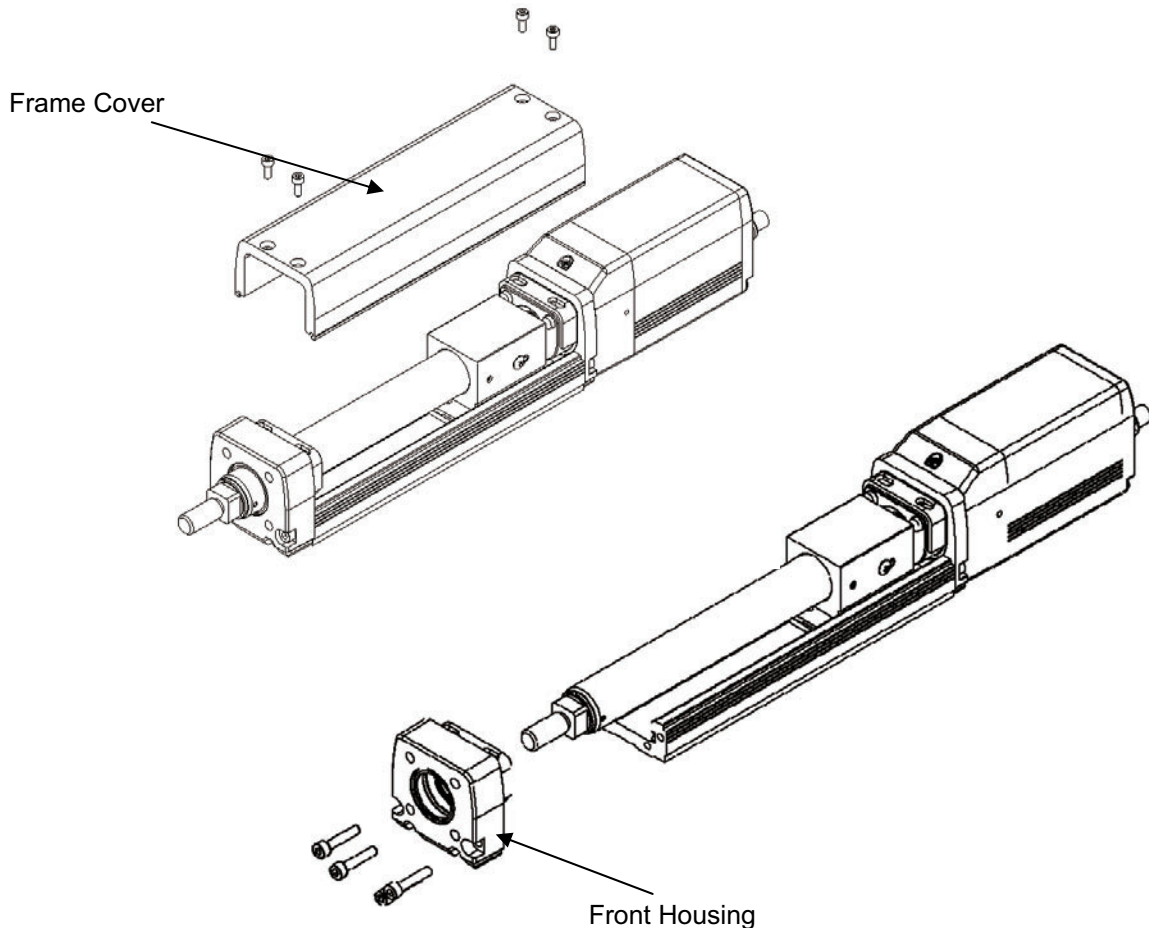

- 3) Detach the scraper.
Attach the scraper for replacement. Pay attention to the orientation of the scraper.

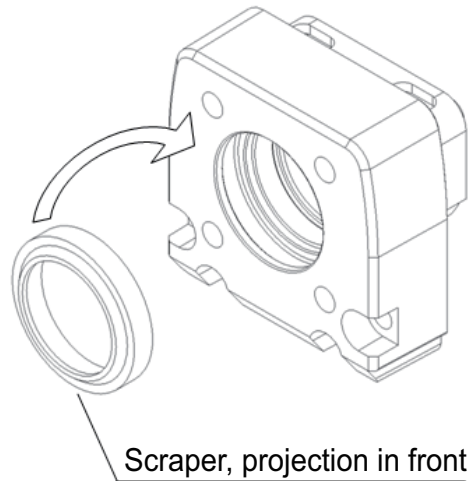

- 4) Affix the front housing temporarily. To tune the center of the front housing, pull out the rod as much as possible and tighten the screws to hold the front housing.
Check if any abnormal resistance to the rod move. If there is, redo the center tuning process.

Screws to Hold Front Housing

Model Name	Screw Diameter × Length	Tightening Torque
RA5C RA5R	M4×20	2.07 N·m(0.21 kgf·m)
RA6C RA6R	M4×25	

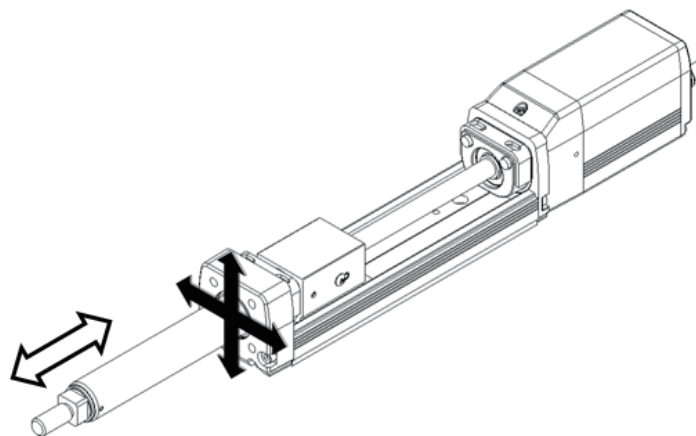

- 5) Apply the grease to the rod sliding surfaces (inside of main body).
[Refer to 5.6 Grease Supply]
- 6) Attach the frame cover and put the actuator back to the original condition.

6. External Dimensions

6.1 RA5C

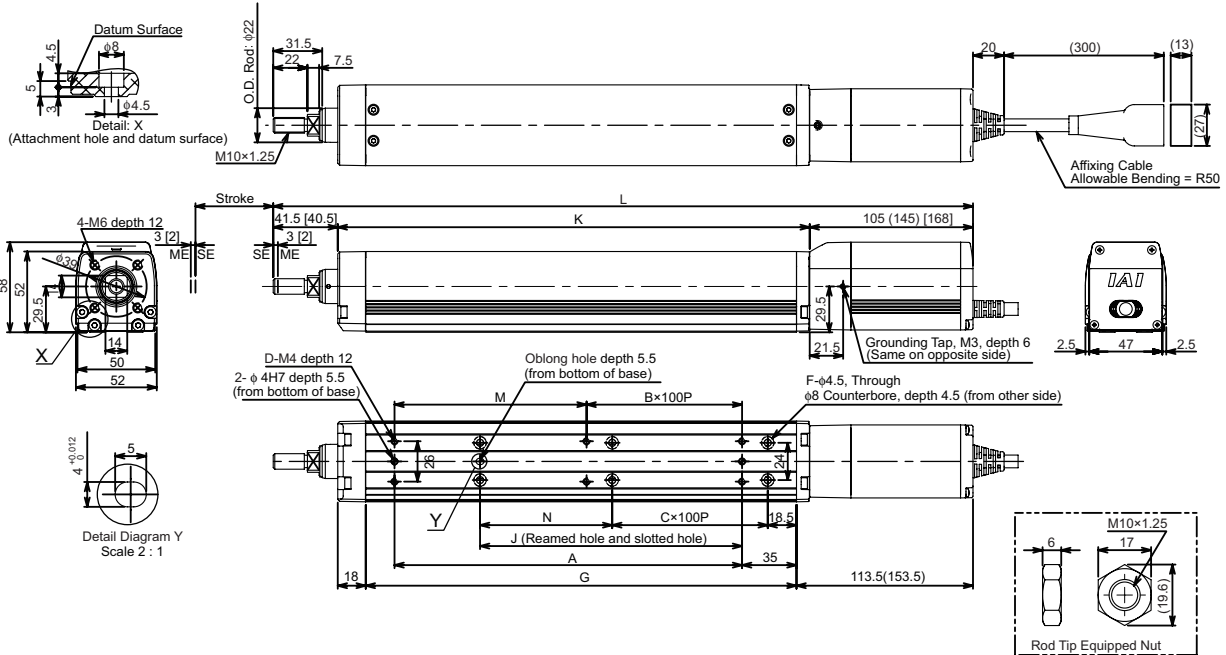

* Dimensions in bracket are for brake-equipped type
 * Dimensions in bracket are for motor types 42SP

Stroke	L			A	B	C	D	F	G	J	K	M	N	Mass [kg]		
	w/o Brake	With Brake	Motor Type 42SP											w/o Brake	With Brake	Motor Type 42SP
50	300	340	360	73.5	0	0	4	4	127	18.5	153.5	73.5	35	1.9	2.1	2.3
100	350	390	410	123.5	0	0	4	4	177	68.5	203.5	123.5	85	2.1	2.4	2.6
150	400	440	460	173.5	1	0	6	4	227	118.5	253.5	73.5	135	2.4	2.6	2.8
200	450	490	510	223.5	1	1	6	6	277	168.5	303.5	123.5	85	2.7	2.9	3.1
250	500	540	560	273.5	2	1	8	6	327	218.5	353.5	73.5	135	2.9	3.1	3.3
300	550	590	610	323.5	2	2	8	8	377	268.5	403.5	123.5	85	3.2	3.4	3.6
350	600	640	660	373.5	3	2	10	8	427	318.5	453.5	73.5	135	3.4	3.7	3.9
400	650	690	710	423.5	3	3	10	10	477	368.5	503.5	123.5	85	3.7	3.9	4.1

6.2 RA6C

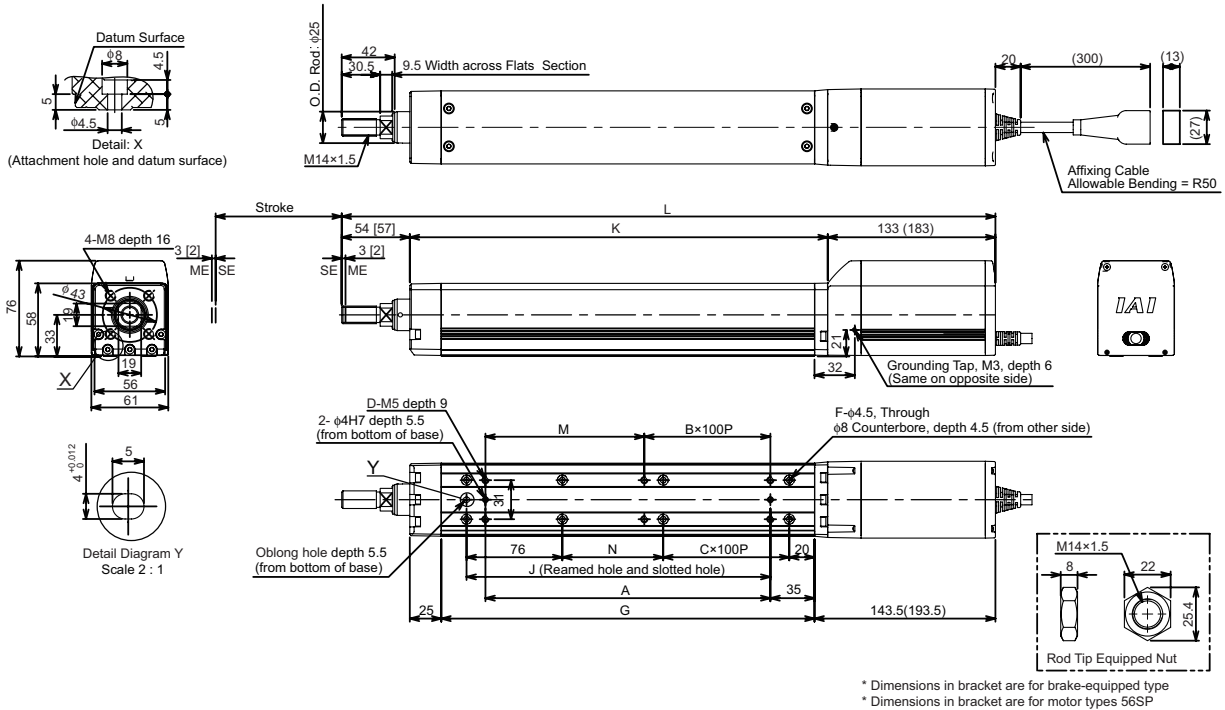

Stroke	L			A	B	C	D	F	G	J	K	M	N	Mass [kg]		
	w/o Brake	With Brake	Motor Type 56SP											w/o Brake	With Brake	Motor Type 56SP
50	368.5	418.5	421.5	76	0	0	4	6	146	91	181.5	76	30	3.4	3.9	3.9
100	418.5	468.5	471.5	126	0	0	4	6	196	141	231.5	126	80	3.7	4.2	4.2
150	468.5	518.5	521.5	176	1	0	6	6	246	191	281.5	76	130	4.1	4.6	4.6
200	518.5	568.5	571.5	226	1	1	6	8	296	241	331.5	126	80	4.4	4.9	4.9
250	568.5	618.5	621.5	276	2	1	8	8	346	291	381.5	76	130	4.7	5.2	5.2
300	618.5	668.5	671.5	326	2	2	8	10	396	341	431.5	126	80	5.0	5.5	5.5
350	668.5	718.5	721.5	376	3	2	10	10	446	391	481.5	76	130	5.4	5.9	5.9
400	718.5	768.5	771.5	426	3	3	10	12	496	441	531.5	126	80	5.7	6.2	6.2
450	768.5	818.5	821.5	476	4	3	12	12	546	491	581.5	76	130	6.0	6.5	6.5
500	818.5	868.5	871.5	526	4	4	12	14	596	541	631.5	126	80	6.3	6.8	6.8

6.4 RA6R

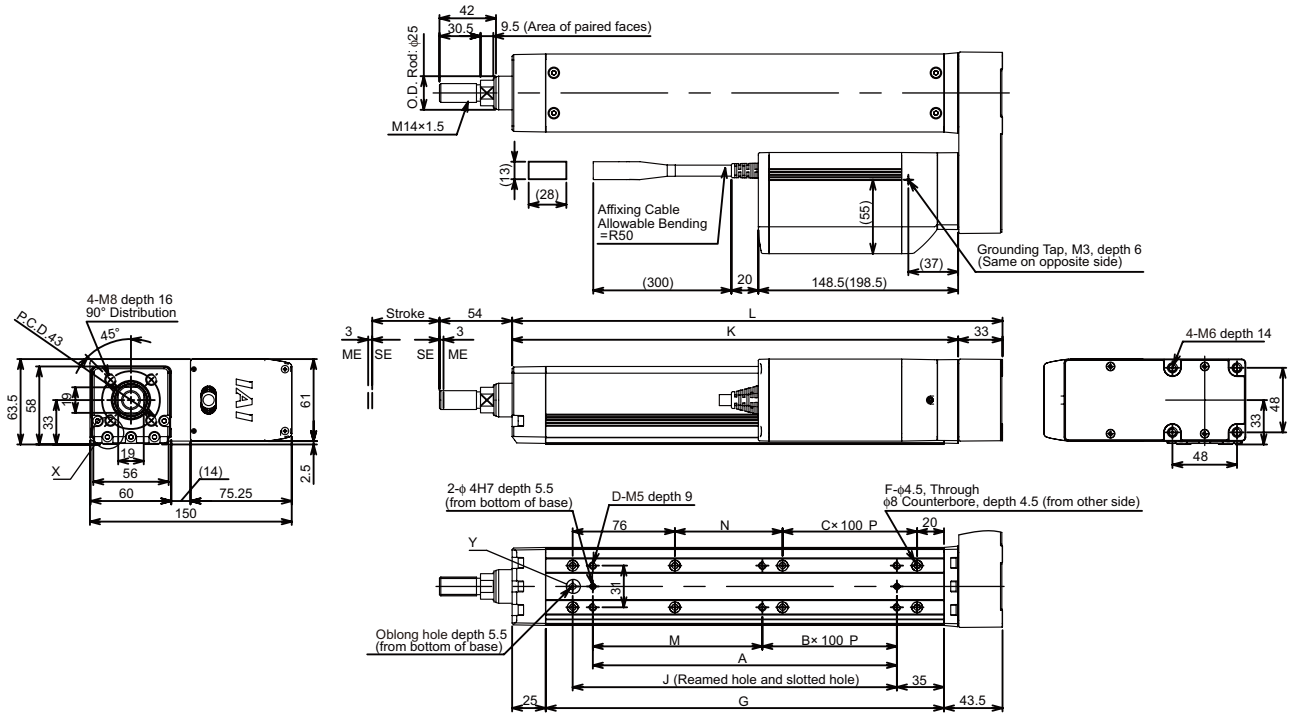

Stroke	L	A	B	C	D	F	G	J	K	M	N	Mass [kg]	
												w/o Brake	With Brake
50	214.5	76	0	0	4	6	146	91	181.5	76	30	3.4	3.9
100	264.5	126	0	0	4	6	196	141	231.5	126	80	3.7	4.2
150	314.5	176	1	0	6	6	246	191	281.5	76	130	4.1	4.6
200	364.5	226	1	1	6	8	296	241	331.5	126	80	4.4	4.9
250	414.5	276	2	1	8	8	346	291	381.5	76	130	4.7	5.2
300	464.5	326	2	2	8	10	396	341	431.5	126	80	5.0	5.5
350	514.5	376	3	2	10	10	446	391	481.5	76	130	5.4	5.9
400	564.5	426	3	3	10	12	496	441	531.5	126	80	5.7	6.2
450	614.5	476	4	3	12	12	546	491	581.5	76	130	6.0	6.5
500	664.5	526	4	4	12	14	596	541	631.5	126	80	6.3	6.8

7. Life

The life is assumed under condition of operation with maximum transported weight and maximum acceleration/deceleration, and it is 5,000km (as a reference) for those models other than RA5-42SP and RA6-56SP. For RA5-42SP and RA6-56SP, it is 3,000km (as a reference).

8. Warranty

8.1 Warranty Period

One of the following periods, whichever is shorter:

- 18 months after shipment from our company
- 12 months after delivery to the specified location
- 2,500 hours of operation

8.2 Scope of the Warranty

Our products are covered by warranty when all of the following conditions are met. Faulty products covered by warranty will be replaced or repaired free of charge:

- (1) The breakdown or problem in question pertains to our product as delivered by us or our authorized dealer.
- (2) The breakdown or problem in question occurred during the warranty period.
- (3) The breakdown or problem in question occurred while the product was in use for an appropriate purpose under the conditions and environment of use specified in the Operation Manual and catalog.
- (4) The breakdown or problem in question was caused by a specification defect or problem, or by the poor quality of our product.

Note that breakdowns due to any of the following reasons are excluded from the scope of warranty:

- [1] Anything other than our product
- [2] Modification or repair performed by a party other than us (unless we have approved such modification or repair)
- [3] Anything that could not be easily predicted with the level of science and technology available at the time of shipment from our company
- [4] A natural disaster, man-made disaster, incident or accident for which we are not liable
- [5] Natural fading of paint or other symptoms of aging
- [6] Wear, depletion or other expected result of use
- [7] Operation noise, vibration or other subjective sensation not affecting function or maintenance

Note that the warranty only covers our product as delivered and that any secondary loss arising from a breakdown of our product is excluded from the scope of warranty.

8.3 Honoring the Warranty

As a rule, the product must be brought to us for repair under warranty.

8.4 Limited Liability

- (1) We shall assume no liability for any special damage, consequential loss or passive loss such as a loss of expected profit arising from or in connection with our product.
- (2) We shall not be liable for any program or control method created by the customer to operate our product or for the result of such program or control method.

8.5 Conditions of Conformance with Applicable Standards/Regulations, Etc., and Applications

- (1) If our product is combined with another product or any system, device, etc., used by the customer, the customer must first check the applicable standards, regulations and/or rules. The customer is also responsible for confirming that such combination with our product conforms to the applicable standards, etc. In such a case we will not be liable for the conformance of our product with the applicable standards, etc.
- (2) Our product is for general industrial use. It is not intended or designed for the applications specified below, which require a high level of safety. Accordingly, as a rule our product cannot be used in these applications. Contact us if you must use our product for any of these applications:
 - [1] Medical equipment pertaining to maintenance or management of human life or health
 - [2] A mechanism or mechanical equipment intended to move or transport people (such as a vehicle, railway facility or aviation facility)
 - [3] Important safety parts of mechanical equipment (such as safety devices)
 - [4] Equipment used to handle cultural assets, art or other irreplaceable items
- (3) Contact us at the earliest opportunity if our product is to be used in any condition or environment that differs from what is specified in the catalog or Operation Manual.

8.6 Other Items Excluded from Warranty

The price of the product delivered to you does not include expenses associated with programming, the dispatch of engineers, etc. Accordingly, a separate fee will be charged in the following cases even during the warranty period:

- [1] Guidance for installation/adjustment and witnessing of test operation
- [2] Maintenance and inspection
- [3] Technical guidance and education on operating/wiring methods, etc.
- [4] Technical guidance and education on programming and other items related to programs

Change History

Revision Date	Description of Revision
September 2011	First edition
November 2011	Second edition Pg. 32 Caution note added regarding cable
February 2012	Third edition Pg. 11 Graph added for stroke and maximum speed limits when high-output setting is ineffective Pg. 17 to 18 Graph added for maximum acceleration and transportable weight when high-output setting is ineffective Pg. 54, 55 Mass added
March 2012	Fourth edition Pg. 7 Caution note added saying "Do not crash the rod to an obstacle with high speed" Pg. 28 Note added to tell platform should have a structure with enough stiffness Pg. 28, 30, 31, 32 Note changed to 1.8 times more of the nominal diameter for the length of thread engagement on aluminum
May 2012	Fifth edition Pg. 1 to 7 Contents added and changed in Safety Guide Pg. 23 Change Rod Non-Rotation Accuracy ($\pm 0.1^\circ \rightarrow 0^\circ$)
July 2012	Sixth edition Pg. 23 Description was added regarding the conditions of the Rod Non-Rotation Accuracy.
August 2012	Seventh edition Revised overall Contents added in Motor reversing type
October 2013	Eighth edition Contents for ROBO Cylinders of motor types 42SP and 56SP added



IAI Corporation

Head Office: 577-1 Obane Shimizu-KU Shizuoka City Shizuoka 424-0103, Japan
TEL +81-54-364-5105 FAX +81-54-364-2589
website: www.iai-robot.co.jp/

Technical Support available in USA, Europe and China

IAI America, Inc.

Head Office: 2690 W. 237th Street, Torrance, CA 90505
TEL (310) 891-6015 FAX (310) 891-0815
Chicago Office: 1261 Hamilton Parkway, Itasca, IL 60143
TEL (630) 467-9900 FAX (630) 467-9912
Atlanta Office: 1220 Kennestone Circle, Suite 108, Marietta, GA 30066
TEL (678) 354-9470 FAX (678) 354-9471
website: www.intelligentactuator.com

IAI Industrieroboter GmbH

Ober der Röth 4, D-65824 Schwalbach am Taunus, Germany
TEL 06196-88950 FAX 06196-889524

IAI (Shanghai) Co., Ltd.

SHANGHAI JIAHUA BUSINESS CENTER A8-303, 808, Hongqiao Rd. Shanghai 200030, China
TEL 021-6448-4753 FAX 021-6448-3992
website: www.iai-robot.com

IAI Robot (Thailand) Co., Ltd.

825 PhairojKijja Tower 12th Floor, Bangna-Trad RD., Bangna, Bangkok 10260, Thailand
TEL +66-2-361-4458 FAX +66-2-361-4456