



RCP2/RCA/RCS2/RCS3 Actuator

Slider Type/Rod Type/ Arm Type/Flat Type

First Step Guide Eighth Edition

Thank you for purchasing our product.
Make sure to read the Safety Guide and detailed Instruction Manual (CD/DVD) included with the product in addition to this First Step Guide to ensure correct use.
This Instruction Manual is original.

Warning : Operation of this equipment requires detailed installation and operation instructions which are provided on the CD/DVD Manual included in the box this device was packaged in. It should be retained with this device at all times.
A hardcopy of the Manual can be requested by contacting your nearest IAI Sales Office listed at the back cover of the Instruction Manual or on the First Step Guide.

- Using or copying all or part of this Instruction Manual without permission is prohibited.
- The company names, names of products and trademarks of each company shown in the sentences are registered trademarks.

Product Check

This product is comprised of the following parts if it is of standard configuration.
If you find any fault in the contained model or any missing parts, contact us or our distributor.

1. Parts (The option is excluded.)

No.	Part Name	Model	Remarks
1	Actuator Main Body	Refer to "2. How to read the model plate", "3. How to read the model No."	
Accessories			
2	Motor + Encoder Cable ¹		
3	Home Position Marking Sticker		Packaged in slider type
4	Nut		Refer to list below
5	First Step Guide		
6	Instruction Manual (CD/DVD)		
7	Safety Guide		

*1 Please refer to the wiring layout for the enclosed motor cable and encoder cable.

(List of Included Nut Type)

Model No.	Nut M10×1.25	Nut M12×1.25	Nut M14×1.5	Nut M20×1.5	Nut M22×1.5	Square Nut 6×6 M4	Square Nut 7×7 M4	Square Nut 10×10 M6
RCP2-RA3C	1							
RCP2-RA4C	1					4		
RCP2-RA6C			1					4
RCP2-RA8C				1				
RCP2-RA10C					1			
RCP2-RA3R	1							
RCP2-RA4R	1					4		
RCP2-RA6R			1					4
RCP2-RA8R				1				
RCP2-RGS4C						4		
RCP2-RGS6C								4
RCP2-RGD4C						4		
RCP2-RGD6C								4
RCP2-SRA4R	1							
RCA-SRA4R	1							
RCS2-RA7AD		1						
RCS2-RA7BD		1						
RCS2-SRA7BD		1						
RCS2-RA5C							4 or 8 ¹	
RCS2-RA5R			1				4 or 8 ¹	
RCS2-RGD5C							4 or 8 ¹	

*1 Stroke 100mm or less : 4 Units, stroke 100mm or more : 8 Units

Model No.	Nut A M26×1.5	Nut B M35×1.5	Nut C M8×1.5	Nut A M30×1.5	Nut B M40×1.5	Nut C M10×1.5
RCA-RA3C	1	1	1			
RCA-RA4C				1	1	1
RCA-RA3D	1	1	1			
RCA-RA4D				1	1	1
RCA-RA3R	2		1			
RCA-RA4R				2		1
RCA-RGS3C	1	1				
RCA-RGS4C				1		1
RCA-RGS3D	1	1				
RCA-RGS4D				1		1
RCA-RGD3C	1	1				
RCA-RGD4C				1		1
RCA-RGD3D	1	1				
RCA-RGD4D				1		1
RCA-RGD3R	2					
RCA-RGD4R				2		1
RCS2-RA4C			1	1	1	1
RCS2-RA4D			1	1	1	1
RCS2-RA4R			2			1
RCS2-RGS4C			1	1	1	1
RCS2-RGS4D			1	1	1	1

2. How to read the model plate

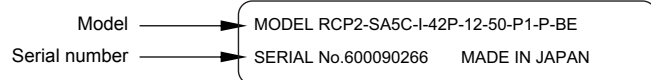

3. How to read the Model No.

3.1 Slider Type

3.1.1 RCP2 Actuator

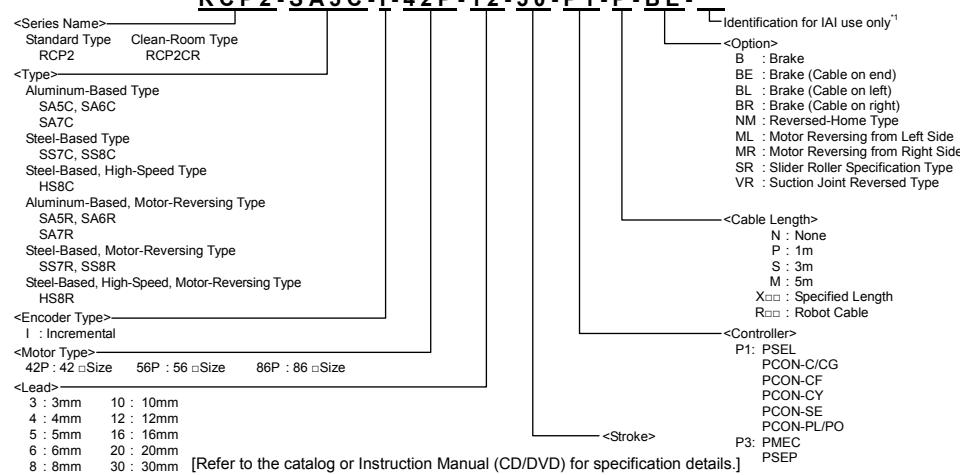

3.1.2 RCA Actuator

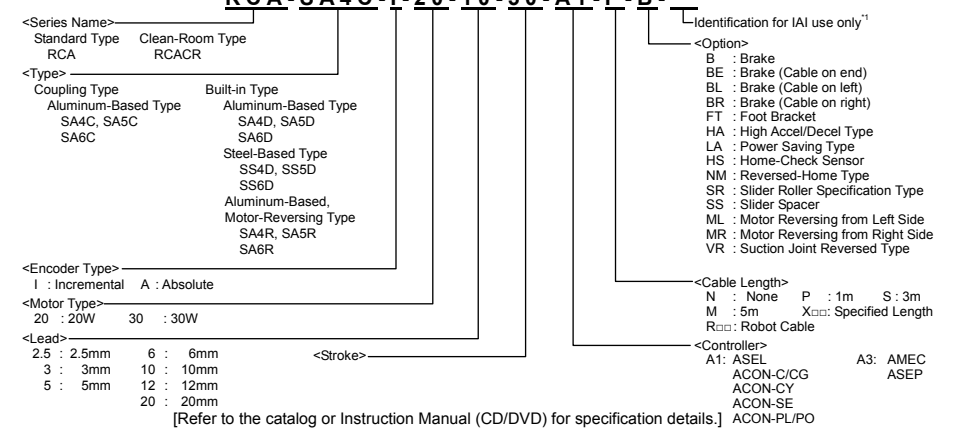

3.1.3 RCS2 Actuator

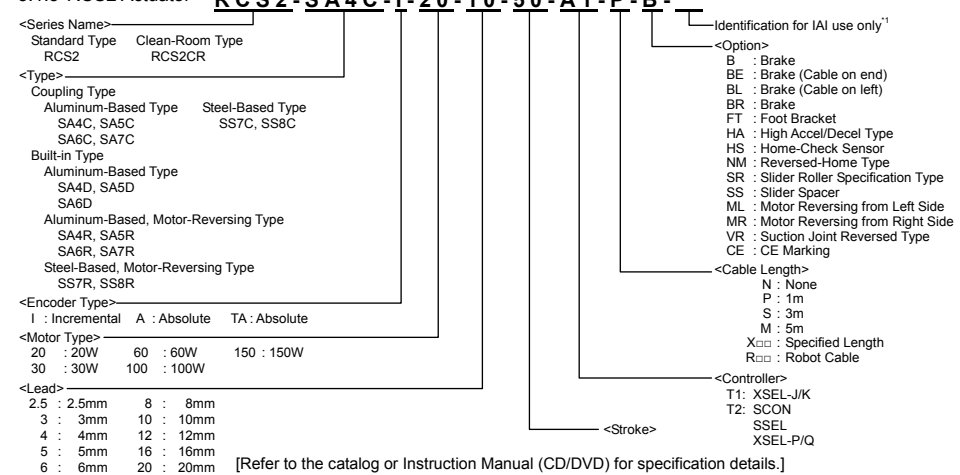

3.1.4 RCS3 Actuator

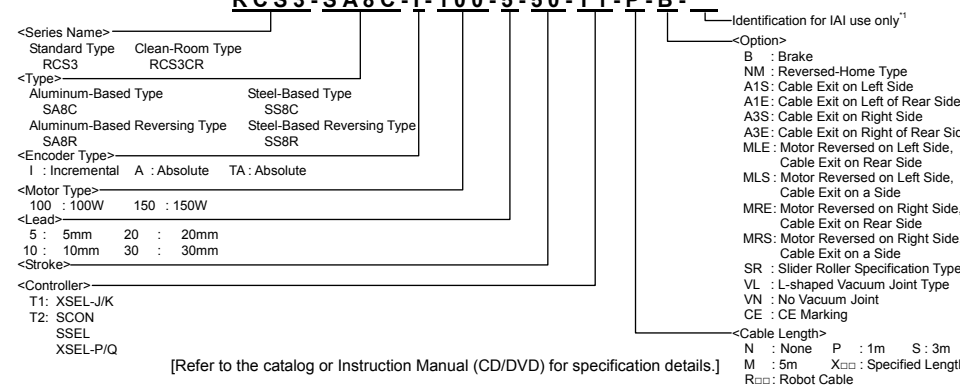

Note : For Absolute Type, there are encoder types A and TA. Check the model types of the actuator and the controller when the controller is one of those listed below. In the case the encoder type differs from what is indicated on the label, it may be necessary to make some changes to the parameters. Please contact your nearest IAI sales office. Using the controller that requires parameter changes will cause D67 (Motor/Encoder Structure Information) Error. However, it would not cause malfunction of the product.
[Applicable Controllers] XSEL-J/K, XSEL-P/Q, SSEL

3.2 Rod Type

3.2.1 RCP2 Actuator

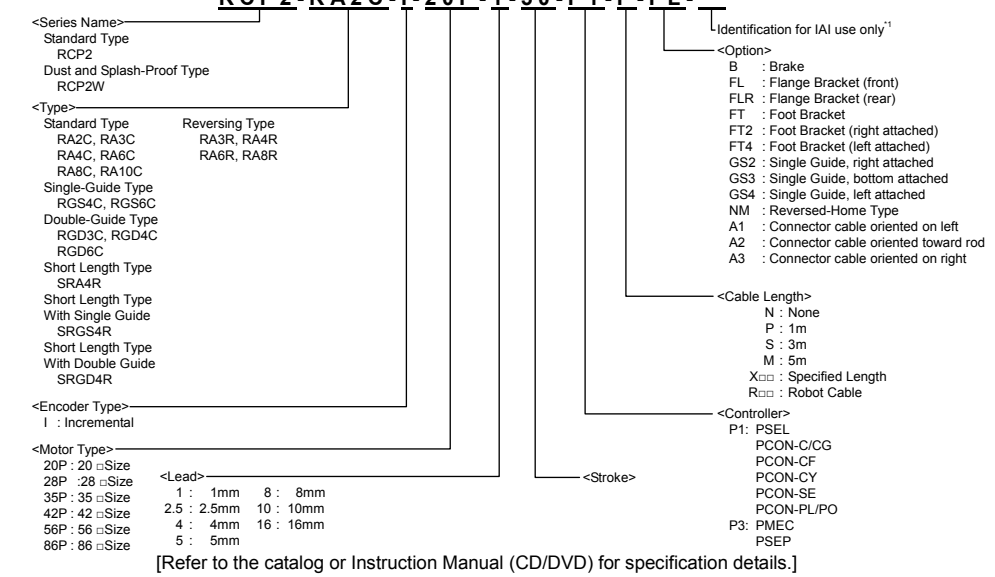

3.2.2 RCA Actuator

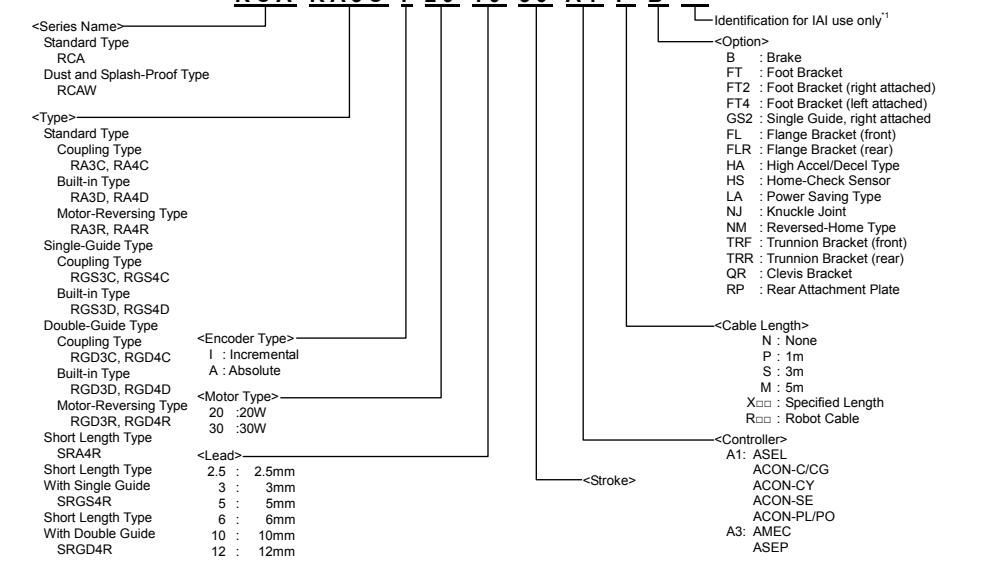

3.2.3 RCS2 Actuator

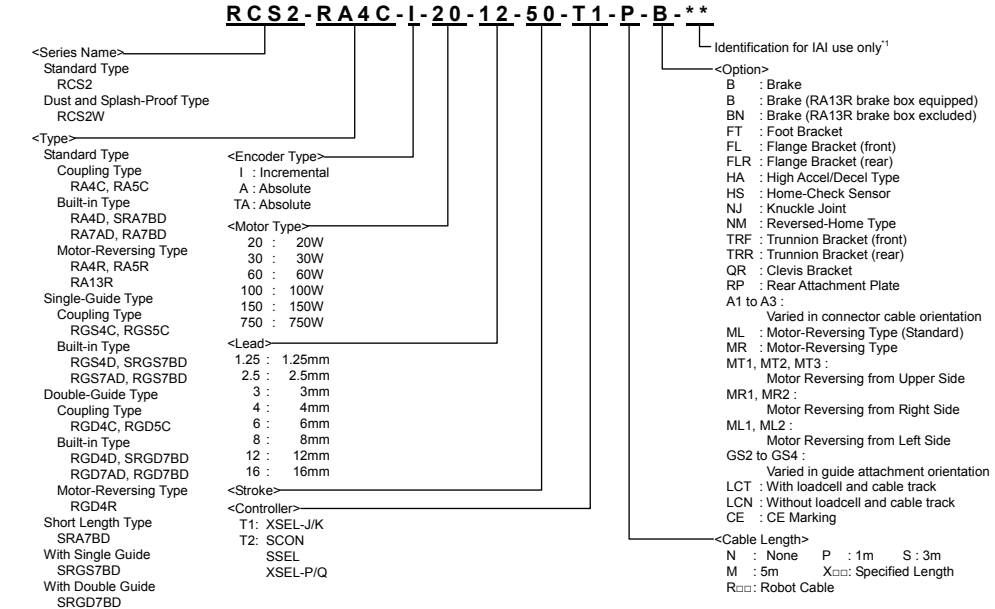

*1 This may be displayed for the manufacturing reason. (This is not to indicate the manufacturing model code.)

Note : For Absolute Type, there are encoder types A and TA. Check the model types of the actuator and the controller when the controller is one of those listed below. In the case the encoder type differs from what is indicated on the label, it may be necessary to make some changes to the parameters. Please contact your nearest IAI sales office. Using the controller that requires parameter changes will cause D67 (Motor/Encoder Structure Information) Error. However, it would not cause malfunction of the product.
[Applicable Controllers] XSEL-J/K, XSEL-P/Q, SSEL

3.3 Arm Type

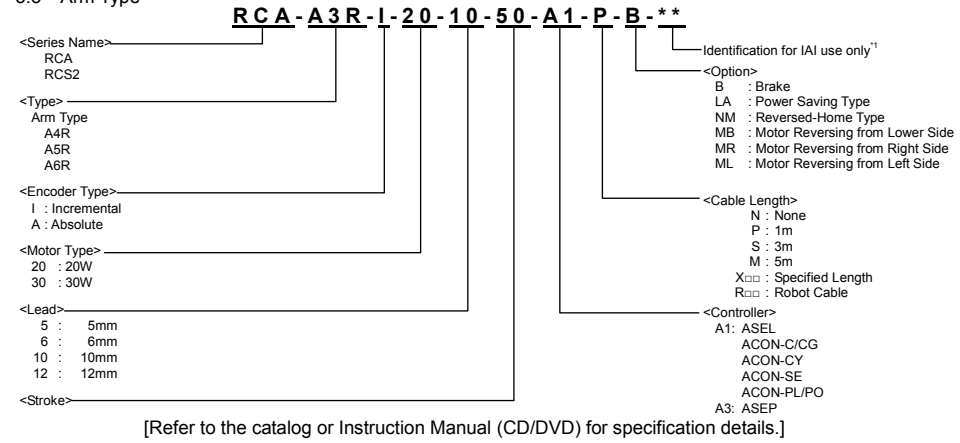

3.4 Flat Type

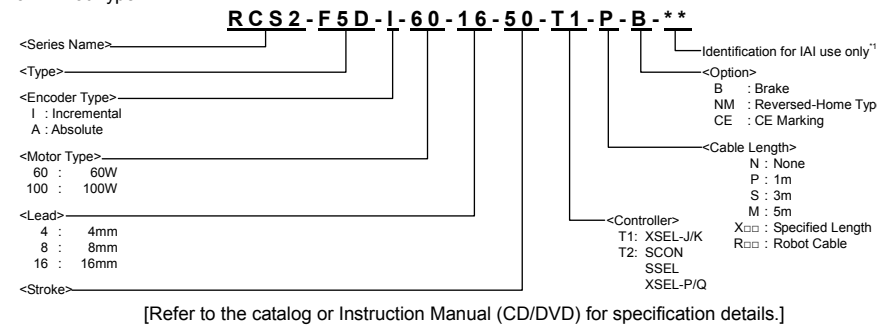

*1 This may be displayed for the manufacturing reason.
(This is not to indicate the manufacturing model code.)

Precautions in Handling

1. Handling of the Packed Product

- Take the greatest care in transporting the product, not to bump or drop it.
- An operator should never attempt to carry a heavy package on his own.
 - When setting down the package temporarily, keep it horizontal.
 - Do not step on the package.
 - Do not place on the package a heavy object that may cause the box deformation or apply stress on it.

2. Handling of the Unpacked Product

- Do not transport the actuator by holding the cable or move it by pulling the cable.

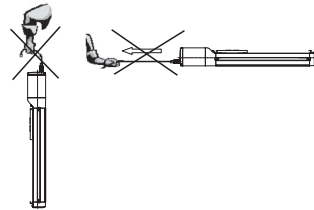

- When the actuator is taken out from the package and handled, hold the base section.
- When the stainless sheet is attached, never hold the stainless sheet section.
- When transporting the actuator, be careful not to hit it against other objects. In particular, pay attention to the side cover.
- Do not give any unnatural force to any of the sections in the actuator. In particular, pay attention not to apply any force on the stainless steel sheet if the actuator is equipped with the stainless steel sheet.

Installation Environment, Storage Environment

1. Installation Environment

An environment that satisfies the following conditions is required during installation. In general, the actuator for standard and clean-room types should be used in the environment where an operator can work without equipping any protective gear.

- There should be no direct sunlight.
- Any radiant heat from a large heat source such as heat treatment furnace should not be directed at the machine main body.
- The ambient temperature should be 0 to 40°C.
- The relative humidity should be 85% or less. There should not be dew condensation. (Standard and clean-room types)
- If air purge is performed, the actuator will have water resistance of the protective structure shown in the table below.
- There should not be corrosive gas or flammable gas.
- There should be no flammable dust or ignitable liquid in the surrounding.
- Oil mist or cutting liquid should not be directed at the machine.
- Chemical liquid should not be splashed on it.
- An impact or vibration should not be transmitted to it.
- There should not be strong electromagnetic waves, ultraviolet rays or radiation.
- The actuator should not be installed where it gets dipped in liquid.
- The working space required for maintenance or inspection should be secured.

Protective Structure	Model
IP65	RCP2W-RA4C, RA6C
IP54	RCP2W-RA10C RCAW-RA3C, RA3D, RA3R RCAW-RA4C, RA4D, RA4R RCS2W-RA4C, RA4D, RA4R

2. Storage and Preservation Environment

- The storage and preservation environment should comply with the same standards as those for the installation environment. In particular, when the machine is to be stored and preserved for a long time, pay close attention to environmental conditions so that no dew condensation forms. Unless specially specified, moisture absorbency protection is not included in the package when the machine is delivered. In the case that the machine is to be stored and preserved in an environment where dew condensation is anticipated, take the condensation preventive measures from outside of the entire package, or directly after opening the package.
- For storage and preservation temperature, the machine withstands temperatures up to 60°C for a short time, but in the case of the storage and preservation period of 1 month or more, control the temperature to 50°C or less.

Names of the Parts

1. Slider Type

1.1 RCP2, RCA, RCS2 Standard Type

1.1.1 Motor Straight Type

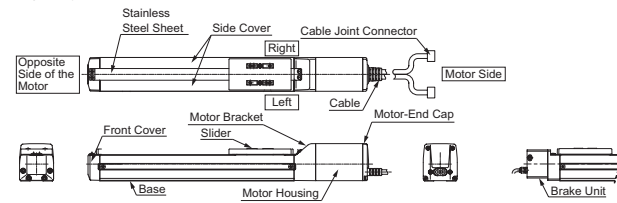

The Figures above are that of RCP2-SA5C, SA6C and SA7C.
For the other details of appearance, dimensions and outlines for the actuator, refer to the catalog or Instruction Manual (CD/DVD).

1.1.2 Motor Reversing Type

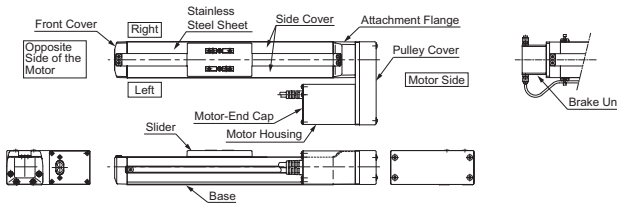

The Figures above are that of RCP2-SA5R and SA6R.
For the other details of appearance, dimensions and outlines for the actuator, refer to the catalog or Instruction Manual (CD/DVD).

1.2 RCP2, RCA, RCS2 Clean-Room Type

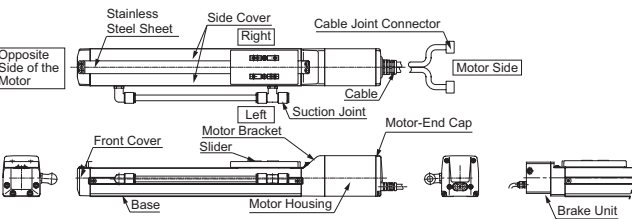

The Figures above are that of RCP2CR-SA5C, SA6C and SA7C.
For the other details of appearance, dimensions and outlines for the actuator, refer to the catalog or Instruction Manual (CD/DVD).

1.3 RCS3 Standard Type

[SA8C]

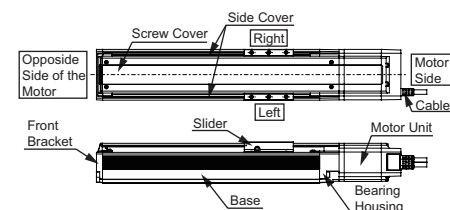

[SS8C]

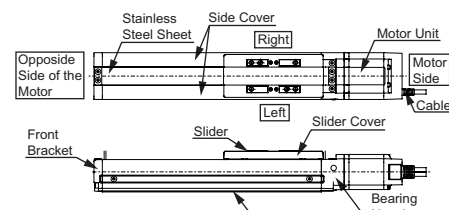

1.4 RCS3 Clean-Room Type

[SA8C]

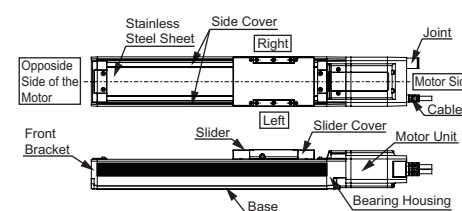

[SS8C]

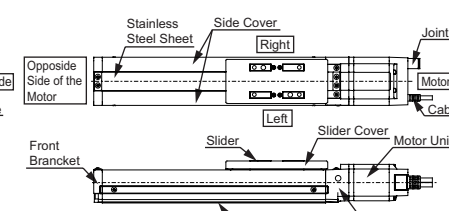

1.5 RCS3 Motor Reversing Type

[SA8R]

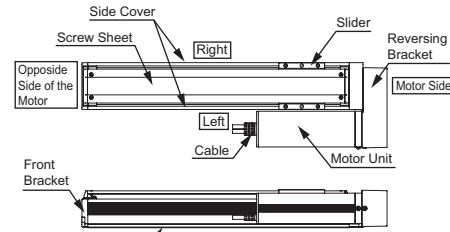

[SS8R]

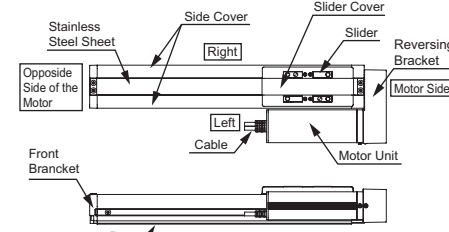

2. Rod Type

2.1 RCP2

2.1.1 Standard Type

[RA2C] There is no brake-equipped type.

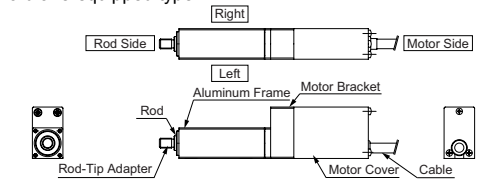

[RA3C] There is no brake-equipped type.

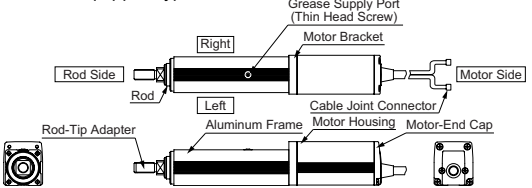

[RA4C, 6C]

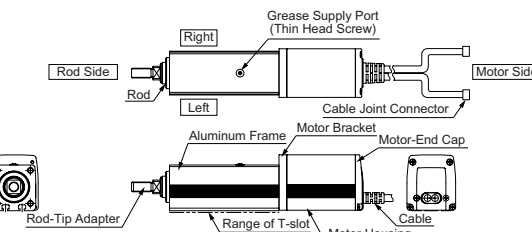

[RA8C]

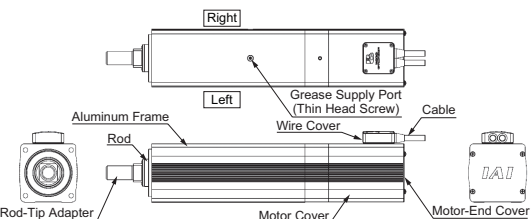

[RA10C]

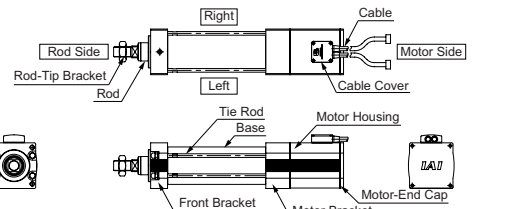

[RA3R]

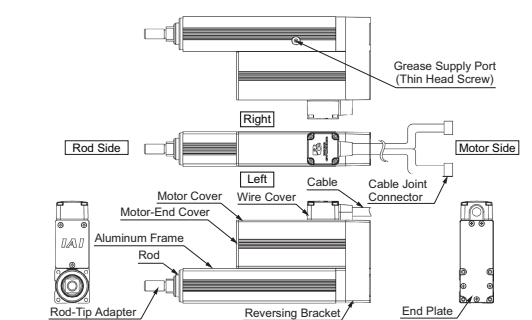

[RA4R, RA6R]

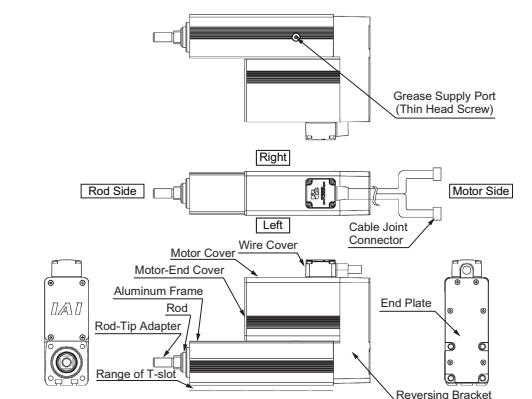

For the details of dimensions and outlines, refer to the catalog or Instruction Manual (CD/DVD).

[RA8R]

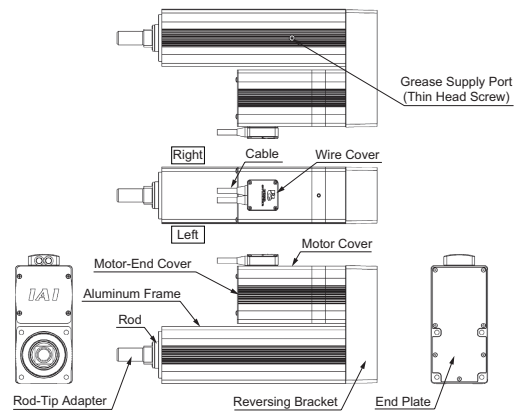

[RGS4C, RGS6C]

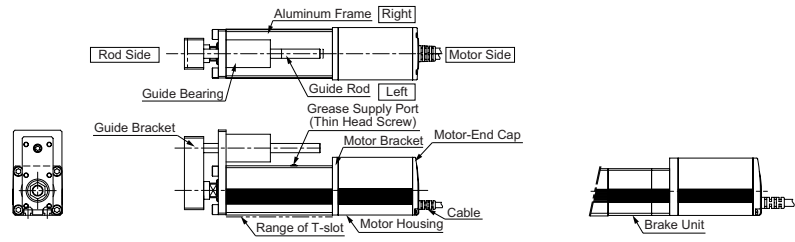

[RGD3C, RGD4C, RGD6C]
There is no brake-equipped type for RGD3C.

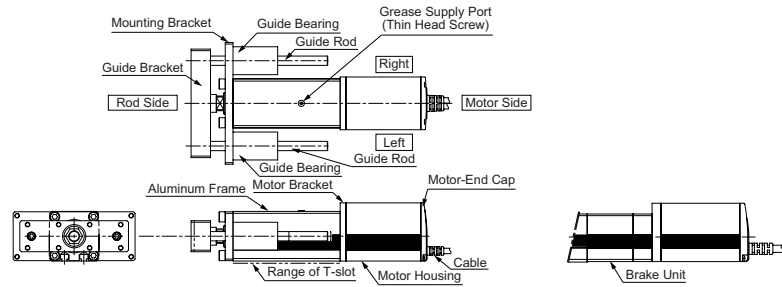

2.1.2 Short Length Type
[SRA4R]
The appearance should be the same for the brake-equipped type.

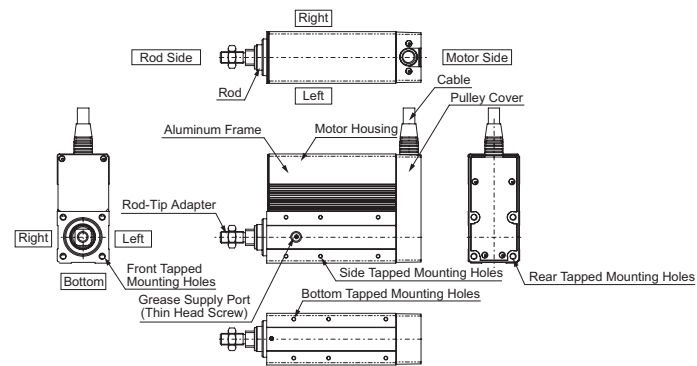

[SRGS4R]
The appearance should be the same for the brake-equipped type.

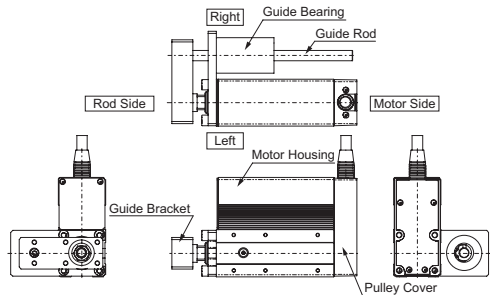

[SRGD4R]
The appearance should be the same for the brake-equipped type.

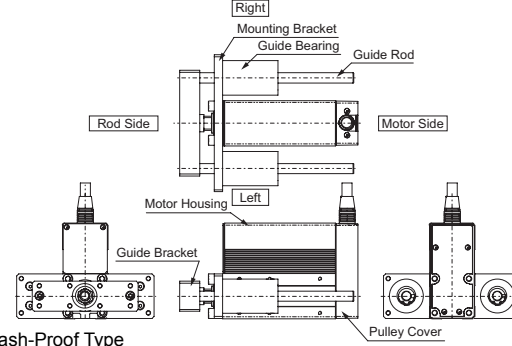

2.1.3 Dust and Splash-Proof Type
[RA4C, RA6C]

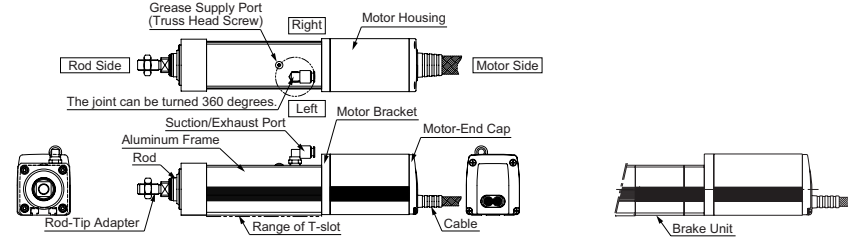

[RA10C]

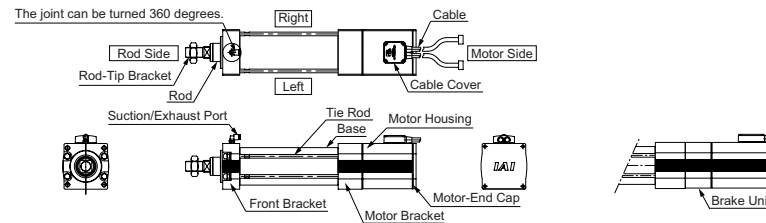

2.2 RCA, RCS2
2.2.1 Standard Type
[RA3C, RA4C]

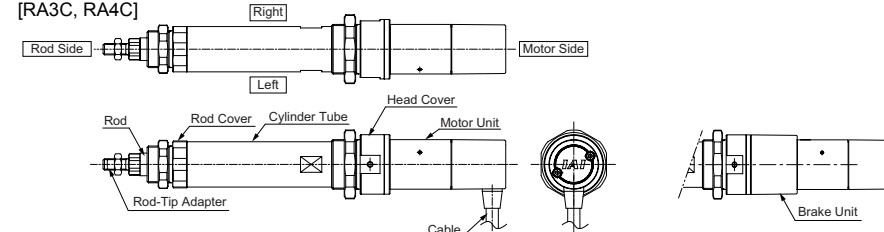

[RA5C]

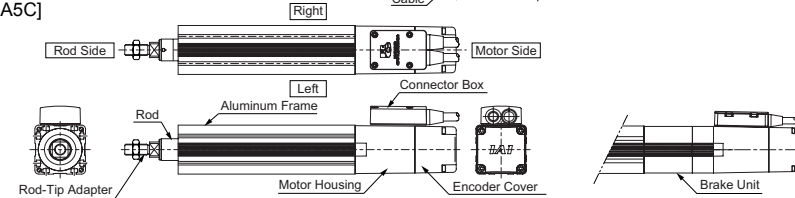

[RA3D, RA4D]
There is no brake-equipped type.

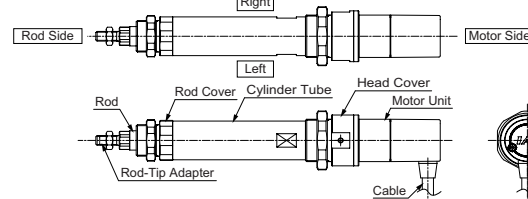

[RA7AD, RA7BD]

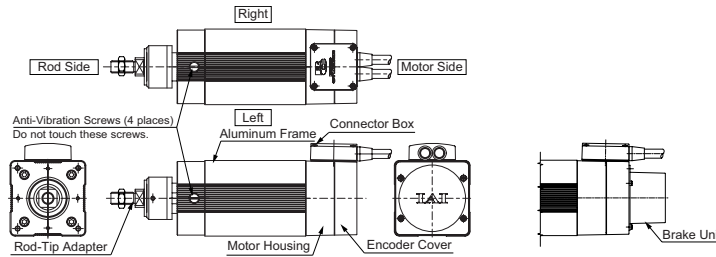

[RA3R, RA4R]

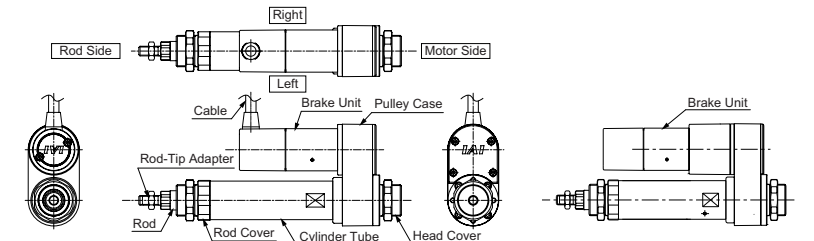

[RA5R]

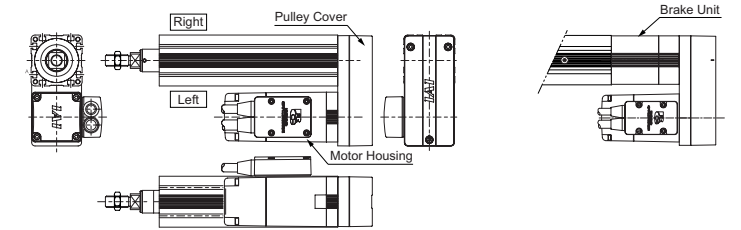

[RA13R]

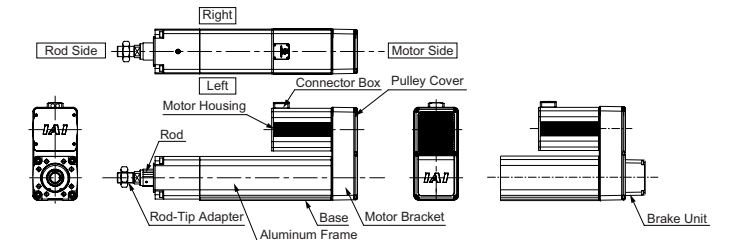

[RGS3C, RGS3D, RGS4C, RGS4D]
There are no brake-equipped types for RGS3D and RGS4D.

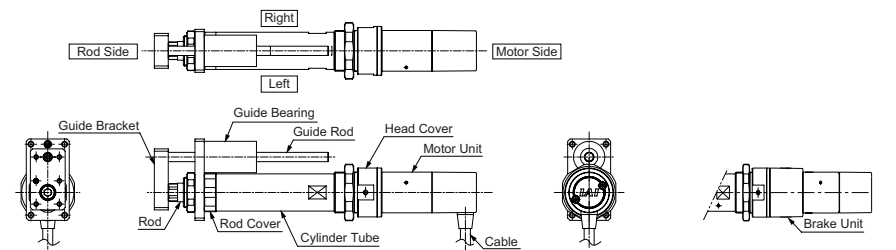

[RGS5C]

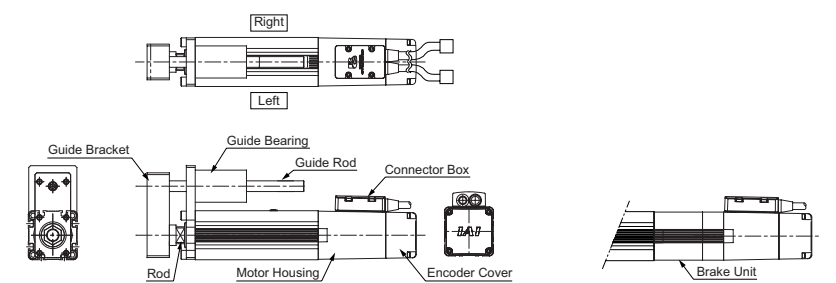

[RGS7AD, RGS7BD]

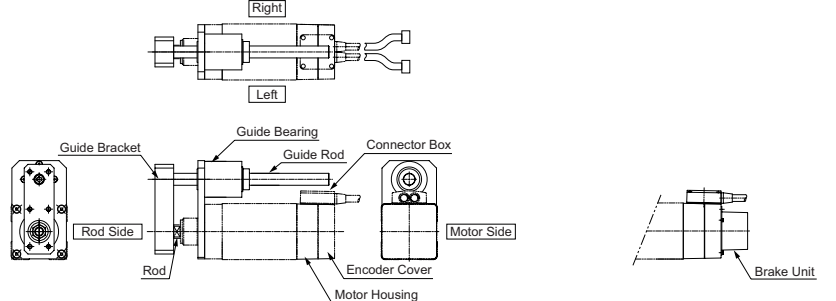

[RGD3C, RGD3D, RGD4C, RGD4D]

There are no brake-equipped types for RGD3D and RGD4D.

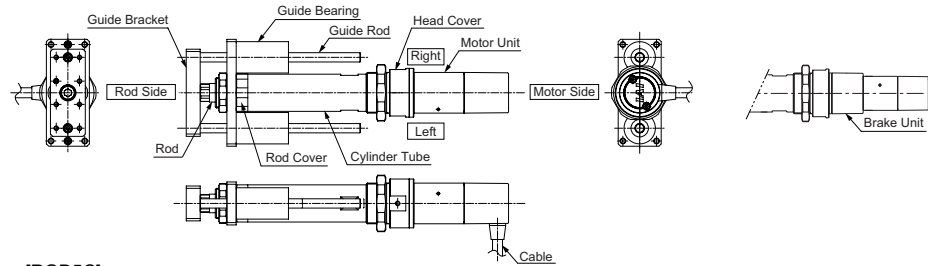

[RGD5C]

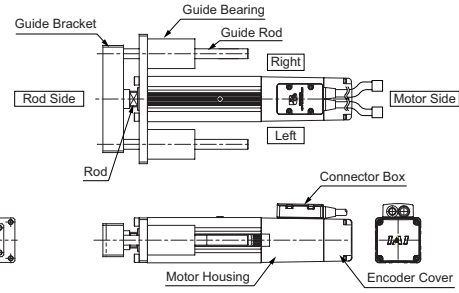

[RGD7AD, RGD7BD]

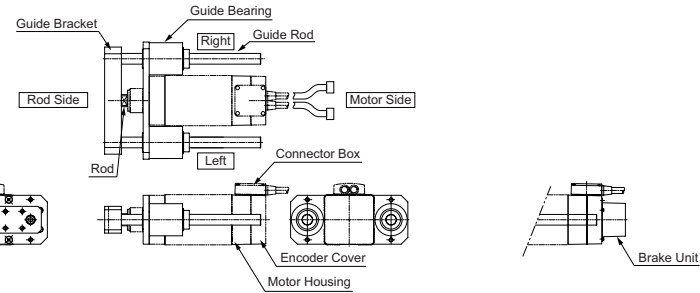

[RGD3R, RGD4R]

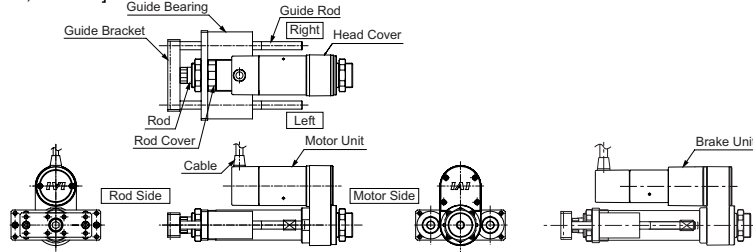

2.2.2 Short Length Type

[SRA4R, SRGS4R, SRGD4R]

The appearance is the same as RCP2-SRA4R, SRGS4R and SRGD4R.

[SRA7BD]

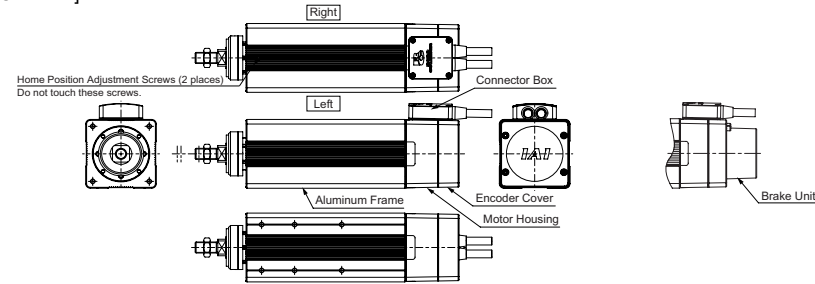

[SRGS7BD]

The appearance should be the same for the brake-equipped type.

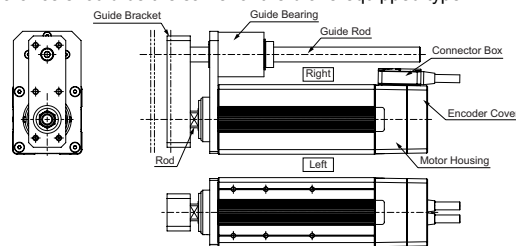

For the details of dimensions and outlines, refer to the catalog or Instruction Manual (CD/DVD).

[SRGD7BD]

The appearance should be the same for the brake-equipped type.

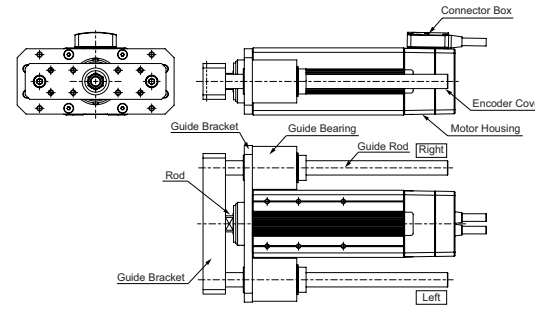

2.2.3 Dust and Splash-Proof Type

[RA3C, RA3D, RA4C, RA4D]

There are no brake-equipped types for RA3D and RA4D.

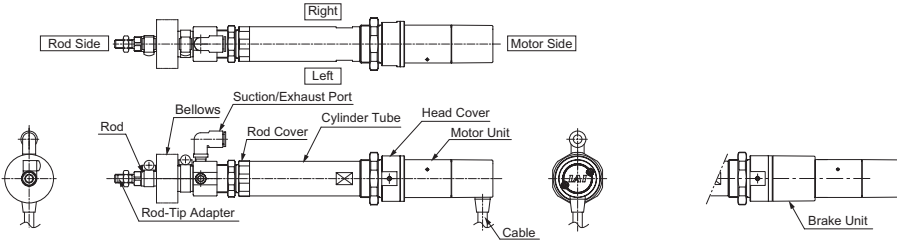

[RA3R, RA4R]

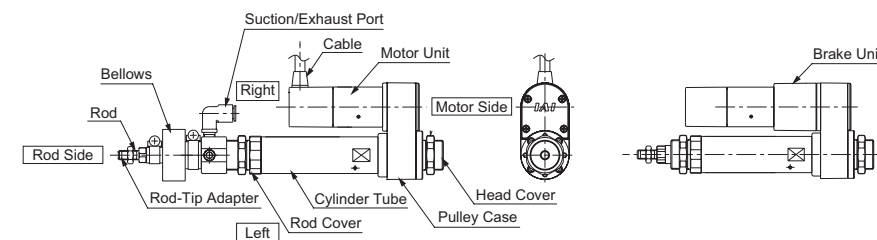

3. Arm Type

3.1 RCA, RCS2

[A4R, A5R, A6R]

Equipped with brake

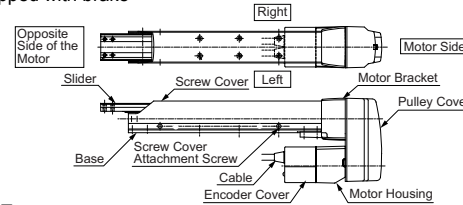

4. Flat Type

4.1 RCS2

[F5D]

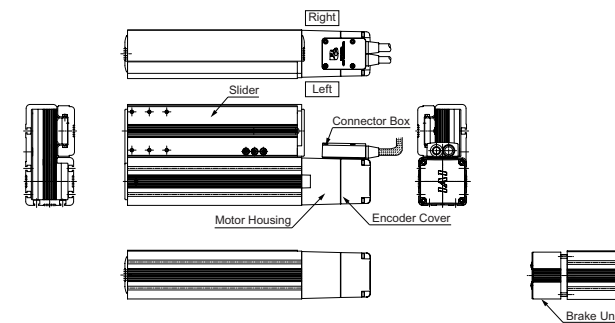



For the details of dimensions and outlines, refer to the catalog or Instruction Manual (CD/DVD).

Attachment

Refer to the Instruction Manual (CD/DVD) for the attachments of the actuator and loads.

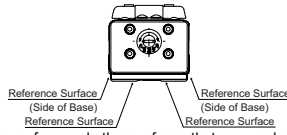
[Precautions for Attachments]

No.	Item	Precautions
1	Installation	<ul style="list-style-type: none"> Installing the slider type actuator with the stroke of 400mm or more to horizontally oriented wall mount or ceiling mount may cause the stainless steel sheet to be slacked or off the right position. Continued use of the actuator with this condition may result in the breakage of the stainless steel sheet. Adjust the sheet tension accordingly in the regular inspection. (Refer to the maintenance section on the Instruction Manual for the procedure of stainless steel sheet tension adjustment.) Avoid using the actuator with no brake in the vertical orientation.
2	Attachment Surface	<ul style="list-style-type: none"> The base has to have a structure with sufficient rigidity to prevent oscillation. The side and the bottom surfaces of the base of the slider type actuator are the datum for the slider drive. If accuracy for its run is required, use these surfaces as a datum of the installation.  <ul style="list-style-type: none"> The actuator mounting surface and other surfaces that are used as a datum should be flat enough with an accuracy of machining or equivalent treatment, and the flatness of the mounting surface needs to be $\pm 0.05\text{mm/m}$ or less. Secure the space where maintenance work can be performed.
3	Bolt to be used	<ul style="list-style-type: none"> For the bolts to be used, a high-tensile bolt complying with ISO-10.9 or more is recommended. If using the tapped holes, use screws with the thread length dimension being less than the effective depth of the holes. In case the tapped hole is a through hole, be careful so the screw tip does not exceed the surface of the tapped hole. For the actuator mounting, use a bolt with the dimension of its effective mating length to the tapped hole is as stated below. <ul style="list-style-type: none"> If tapped hole on steel \rightarrow thread length same as nominal diameter If tapped hole on aluminum \rightarrow thread length 2 times longer than nominal diameter When using a foot base for installation to a platform or equivalent, in order to protect the foot base, apply washers dedicated for high-tensile bolt if using bolts of M8 or larger. No washer is needed for M6 or smaller bolts. Also, do not use a normal washer.
4	Tightening Torque	<ul style="list-style-type: none"> Please follow the specification values stated in the Instruction Manual (CD/DVD) for the tightening torque. Failure to do so may cause an operation problem.
5	Load Moment and Overhung length	<ul style="list-style-type: none"> Please follow the specification values stated in the Instruction Manual (CD/DVD) for the load moment and the overhung length. Failure to do so may cause abnormal vibration or noise, and also may remarkably shorten the product life. Please do not apply any external force from other than rod moving direction (radial load) to the rod. Any perpendicular or radial force to the rod may cause damage to the actuator or operation problem. Use an actuator with a guide or equip the actuator with an optional guide if the actuator receives an external force from the direction other than its moving direction.
6	Stainless sheet	<ul style="list-style-type: none"> Please do not hold the stainless steel sheet directly with hands. Please, also, be careful not to make a dent on the stainless steel sheet. Stainless sheet is easy to get dented because it is thin. Using it with a dent on may cause a breakage. If there is dust or metal contamination attached on the stainless steel sheet, please wipe it off the sheet surface. Operation with the stainless sheet that has foreign matters on its surface may cause problems such as sheet damage, waviness, etc. inside the slider. Please do not operate the unit in the ambient with dust or metal contamination.
7	Load Attachment to Rod	<ul style="list-style-type: none"> Do not apply rotation torque on the rod (side shaft). It may cause damage inside.  <ul style="list-style-type: none"> Tighten the nut on the rod tip with holding the rot with a wrench or an equivalent tool.

Wiring

For the controller, only the dedicated controller manufactured by our company can be used.

For the connection between the actuator and controller, use the attached dedicated connection cable.

1. RCP2, RCP2CR, RCP2W Actuator

[Connection to the PCON, PSEL controller]

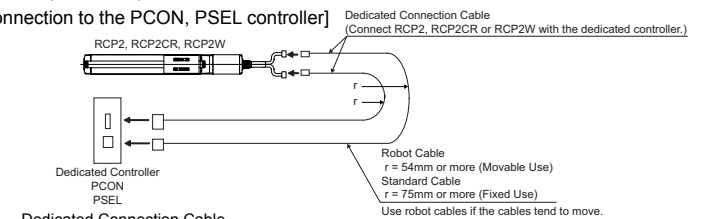

- Dedicated Connection Cable
- Motor Cable (Robot Cable) CB-RCP2-MA***
 - Encoder Cable CB-RCP2-PB***/Encoder Cable Robot Cable CB-RCP2-PB***-RB
- *** shows the cable length. The max. length should be 20m.
Example) 080-8m

[Connection to the PMEC, PSEP controller]

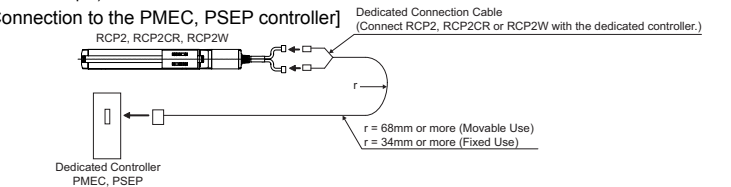

- Dedicated Connection Cable
- Motor Encoder Cable CB-PSEP-MPA***
- *** shows the cable length. The max. length should be 20m.
Example) 080-8m

2. RCA, RCACR, RCAW Actuator

[Connection to the ACON, ASEL controller]

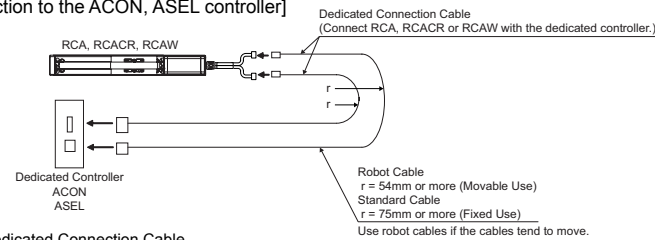

Dedicated Connection Cable

- Motor Cable (Robot Cable) CB-ACS-MA***
 - Encoder Cable CB-ACS-PA***/Encoder Cable Robot Cable CB-ACS-PA***-RB
- *** shows the cable length. The max. length should be 20m.
Example) 080=8m

[Connection to the AMEC, ASEP controller]

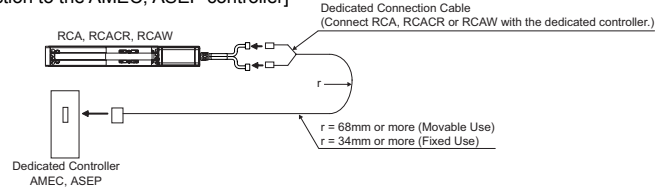

Dedicated Connection Cable

- Motor Encoder Cable CB-ASEP-MPA***
- *** shows the cable length. The max. length should be 20m.
Example) 080=8m

3. RCS2, RCS2CR, RCS2W, RCS3, RCS3P, RCS3CR, RCS3PCR Actuator

[Connection to the SCON, SSEL controller]

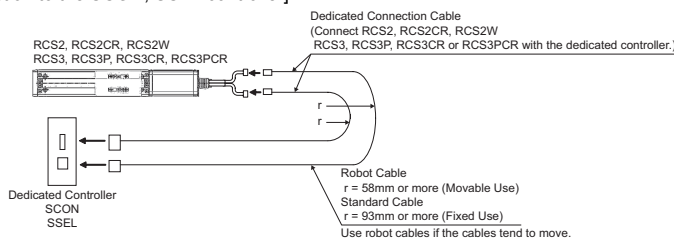

Dedicated Connection Cable

- Motor Cable CB-RCC-MA***/Motor Cable Robot Cable CB-RCC-MA***-RB
 - Encoder Cable CB-RCS2-PA***/Encoder Cable Robot Cable CB-X3-PA***
- *** shows the cable length. The max. length should be 30m.
Example) 080=8m

[Connection to the X-SEL controller]

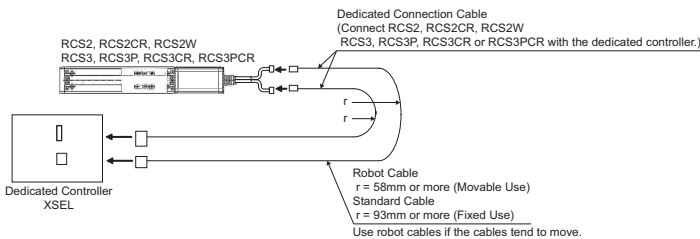

Dedicated Connection Cable

- Motor Cable CB-RCC-MA***/Motor Cable Robot Cable CB-RCC-MA***-RB
 - Encoder Cable dedicated for XSEL-J/K types CB-RCBC-PA***
 - Encoder Cable Robot Cable dedicated for XSEL-J/K types CB-RCBC-PA***-RB
 - Encoder Cable dedicated for XSEL-P/Q types CB-RCS2-PA**
 - Encoder Cable Robot Cable dedicated for XSEL-P/Q types CB-X3-PA***
- *** shows the cable length.
The max. length should be 15m. The max. length for other cables is 20m.
Example) 080=8m

[Connection to the RCS2-RA13R and SCON controller]

◎ Brake-Equipped Type

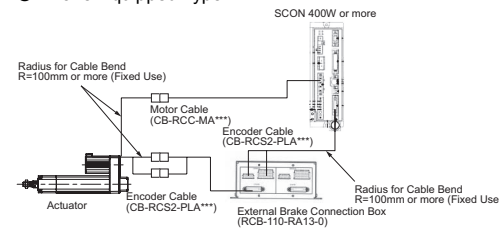

◎ Non-Brake Type

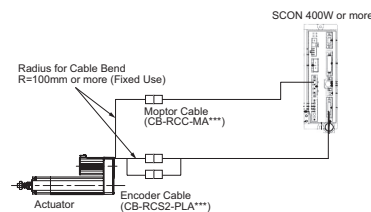

◎ Loadcell-Equipped Type (Option)

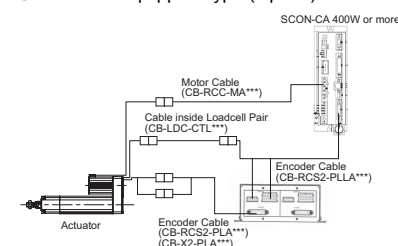

[Prohibited Items in the Cable Processing]

- Do not pull or bend forcibly the cable so as not to give any extra load or tension to the cable.
- Do not process the cable for extension or shortening by means of cutting out, combination or connecting with another cable.
- Do not let the cable flex at a single point.

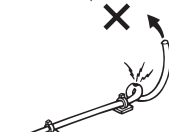
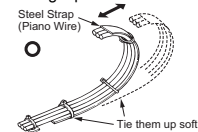
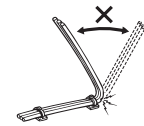

- Do not pull the cable with a strong force.

- Do not let the cable receive a turning force at a single point.

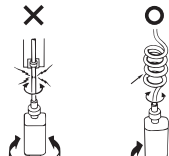
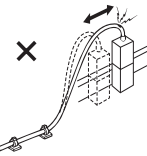

- Do not pinch, drop a heavy object onto or cut the cable.

- When fixing the cable, provide a moderate slack and do not tension it too tight.

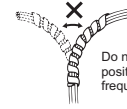
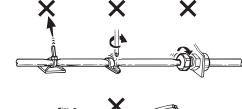
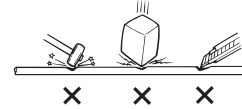

Do not use spiral tube in any position where cables are bent frequently.

- Separate the I/O line, communication line and power line from each other. Arrange so that such lines are independently routed in the duct.

- Take care of the following items using the cable carrier.
- Arrange the wiring so that there is no entanglement or kink of the cables in the cable carrier or flexible tube, and do not bind the cables so that the cables are relatively free (Do not bend it at an angle of 90° or less).

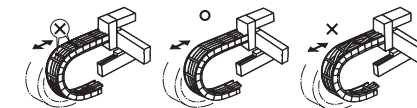
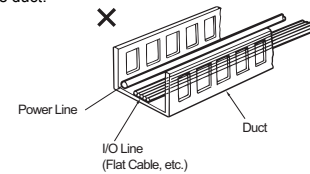

- The cable track capacity for cables to put in should be 60% or less to prevent cables from breaking. (Cable heat is not considered.)

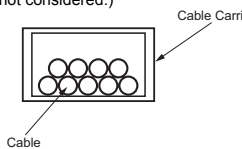

- ⚠ Note:
 - When the cable is connected or disconnected, make sure to turn off the power to the controller. When the cable is connected or disconnected with the controller power turned ON, it might cause a malfunction of the actuator and result in a serious injury or damage to the machinery.
 - When the connector connection is not correct, it would be dangerous because of a malfunction of the actuator. Make sure to confirm that the connector is connected correctly.

IAI
Quality and Innovation

IAI Corporation

Head Office: 577-1 Obane Shimizu-KU Shizuoka City Shizuoka 424-0103, Japan
TEL +81-54-364-5105 FAX +81-54-364-2589
website: www.iai-robot.co.jp/

Technical Support available in USA, Europe and China

IAI America, Inc.

Head Office: 2690 W, 237th Street Torrance, CA 90505
TEL (310) 891-6015 FAX (310) 891-0815
Chicago Office: 1261 Hamilton Parkway Itasca, IL 60143
TEL (630) 467-9900 FAX (630) 467-9912
Atlanta Office: 1220 Kennestone Circle Suite 108 Marietta, GA 30066
TEL (678) 354-9470 FAX (678) 354-9471
website: www.intelligentactuator.com

IAI Industrieroboter GmbH

Ober der Röth 4, D-65824 Schwalbach am Taunus, Germany
TEL 06196-88950 FAX 06196-889524

IAI (Shanghai) Co., Ltd.

SHANGHAI JIAHUA BUSINESS CENTER A8-303, 808, Hongqiao Rd. Shanghai 200030, China
TEL 021-6448-4753 FAX 021-6448-3992
website: www.iai-robot.com

Manual No.: ME3687-8A