

SMAC



MOVING COIL ACTUATORS

The ability to do work and verify its accuracy at the same time.

SMAC Product Overview

Cylinder



CAL12
Stroke [mm]: 10
Force [N]: 1.5



CAL36
Stroke [mm]: 15, 25, 50
Force [N]: 12 - 41



CAL75
Stroke [mm]: 15, 25, 50
Force [N]: 25 - 150

Linear & Linear/Rotary Actuators



LCA8
Stroke [mm]: 10, 25, 50
Force [N]: 2.6 - 4



LCA16
Stroke [mm]: 10
Force [N]: 6, 13



LCA25
Stroke [mm]: 10 - 200
Force [N]: 7.4 - 22



LCA31
Stroke [mm]: 12
Force [N]: 38



LCA50
Stroke [mm]: 25, 50, 100
Force [N]: 40 - 110



LAL15 / LAR15
Stroke [mm]: 15
Force [N]: 5



LAL20 / LAR20
Stroke [mm]: 10, 15, 25
Force [N]: 5.4 - 12



LAR31
Stroke [mm]: 30, 50
Force [N]: 11, 20



LAL35 / LAR35
Stroke [mm]: 25, 50, 100
Force [N]: 6 - 31.5



LAL55 / LAR55
Stroke [mm]: 50, 100, 150
Force [N]: 13 - 40



LAL95 / LAR95
Stroke [mm]: 15, 25, 50
Force [N]: 65 - 185



LAL300 / LAR300
Stroke [mm]: 50
Force [N]: 202



LAL500
Stroke [mm]: 25, 50
Force [N]: 500

Linear Slide Actuators



LCS8
Stroke [mm]: 10, 25, 50
Force [N]: 2.6 - 4



LCS25
Stroke [mm]: 10 - 200
Force [N]: 7.4 - 22



LCS30
Stroke [mm]: 10
Force [N]: 4, 6



LCS50
Stroke [mm]: 25, 100, 250
Force [N]: 30 - 110



LAS15
Stroke [mm]: 15
Force [N]: 5



LAS20
Stroke [mm]: 10, 15, 25
Force [N]: 8, 7, 5.5



LAS20W
Stroke [mm]: 25
Force [N]: 19



LAS35
Stroke [mm]: 25, 50, 100
Force [N]: 6 - 31.5



LAS55
Stroke [mm]: 50, 100, 150
Force [N]: 13 - 40

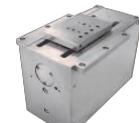

LAS95
Stroke [mm]: 15, 25, 50
Force [N]: 65 - 185



LAS300
Stroke [mm]: 50
Force [N]: 202

Grippers



GRP20
Stroke [mm]: 10
Force [N]: 8



GRP35
Stroke [mm]: 30
Force [N]: 25, 26



GRP50
Stroke [mm]: 30
Force [N]: 35, 45

XY Stages



LXY15
Stroke [mm]: 15
Force [N]: 22



LXY25
Stroke [mm]: 25
Force [N]: 42

Controllers & Amplifier



LCC-10 (LCC-11)
Single axis brushless controller



LAC-1
Single axis controller

NEW



LAC-26
2 axis controller with built in amplifier



LAC-25
2 axis controller with built in amplifier



LAC-45
4 axis controller with built in amp



MAAC4-7
Multi axis [4] Galil based controller



LAA-5
Single axis amplifier



LAD-1
Single axis smart driver



MIOE-8/8
Expansive I/O module for LAC-1, LAC-25 and LAC-45

The SMAC Advantages

- Absolute control over: force, position, acceleration and velocity
- Direct drive actuator, therefore a very high degree of accuracy & repeatability
- Integrated position measuring system with glass scale and optical reader head (no wear)
- Very long life cycle due to oversized linear guides
- Force measurement through monitoring of current
- Digital and analog in/output channels
- Ability to switch between operations - force, position and velocity mode - at any time
- Extremely high acceleration and velocity
- Unique “Soft-Land” function

Programmable Features

The actuator is totally programmable for force, acceleration and velocity, and can operate in three different modes:

Force Mode: Force Mode is open loop, using no feed back from the encoder. The actual position is still monitored but has no effect upon the output.

Velocity Mode: Velocity Mode allows the actuating rod to be moved with a given velocity, acceleration, force and direction. Typically used for a “Soft-Land” routine.

Position Mode: Position Mode will allow the actuating rod to be moved to various positions along the stroke using acceleration, velocity and force. It is possible to perform absolute, relative and “learned position” moves.

What is a Soft-Land?

The “**Soft-Land**” is a routine which allows the actuator rod or gripper jaw to land on the surface of a component with a low programmed force. This is particularly useful for handling delicate or high value components.

The routine consists of a controlled low force approach in velocity mode, whilst the position error is constantly monitored. Once contact is made the position error builds up until a pre-programmed figure is reached - resulting in the rod maintaining position on the surface of the component.

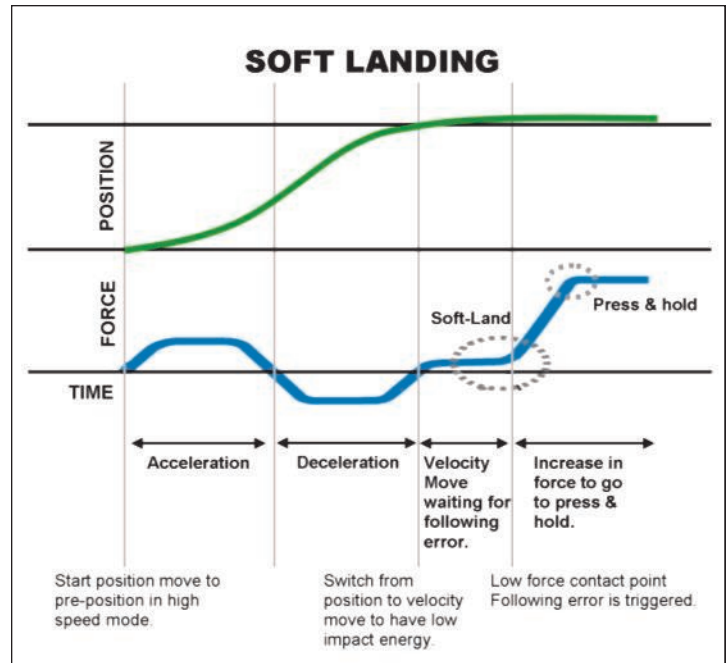

Moving Coil Technology (Voice Coil)

At the heart of all SMAC actuators is the moving coil, also described as a voice coil actuator. The essential principle is the same as you will find in any permanent magnet loudspeaker. The coil is enclosed in a magnet housing, and by passing a current through the coil, a magnetic field is generated.

The amount of force generated is governed by the equation

$$F \propto N I B$$

where;

- F** is the force generated
- N** is the number of turns in the winding (Constant)
- I** is the current flowing through the winding and
- B** is the magnetic flux (Constant)

Therefore, doubling **I (current)** doubles **F (Force)**.

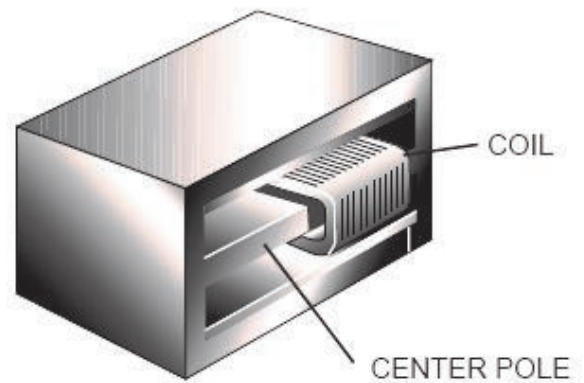
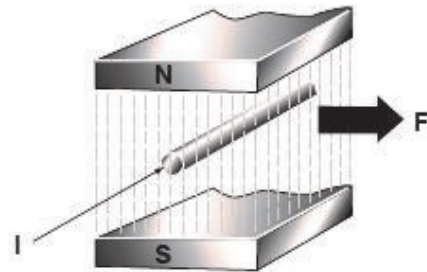

Electric Cylinder

The CA range of multi patented electric cylinders have been designed with the most demanding & arduous of automation tasks in mind. That's why they are ideal for high speed packaging, labelling & bottling applications, pick & place systems, parts feeders & electronic assembly machines along with many, many others where the need for speed, accuracy, precision & repeatability is paramount. They have been designed to replace & fit exactly where standard pneumatic cylinders are currently used but need continuous repair, replacement & maintenance due to high cycle rates, shock & wear. With the SMAC CA range these shortcomings are eradicated.

Linear:

- Stroke up to 50mm, force up to 150N, position encoder resolution 5 μ m standard, 1 and 0.1 μ m option for most actuators.
- Programmable force, position, acceleration and velocity.

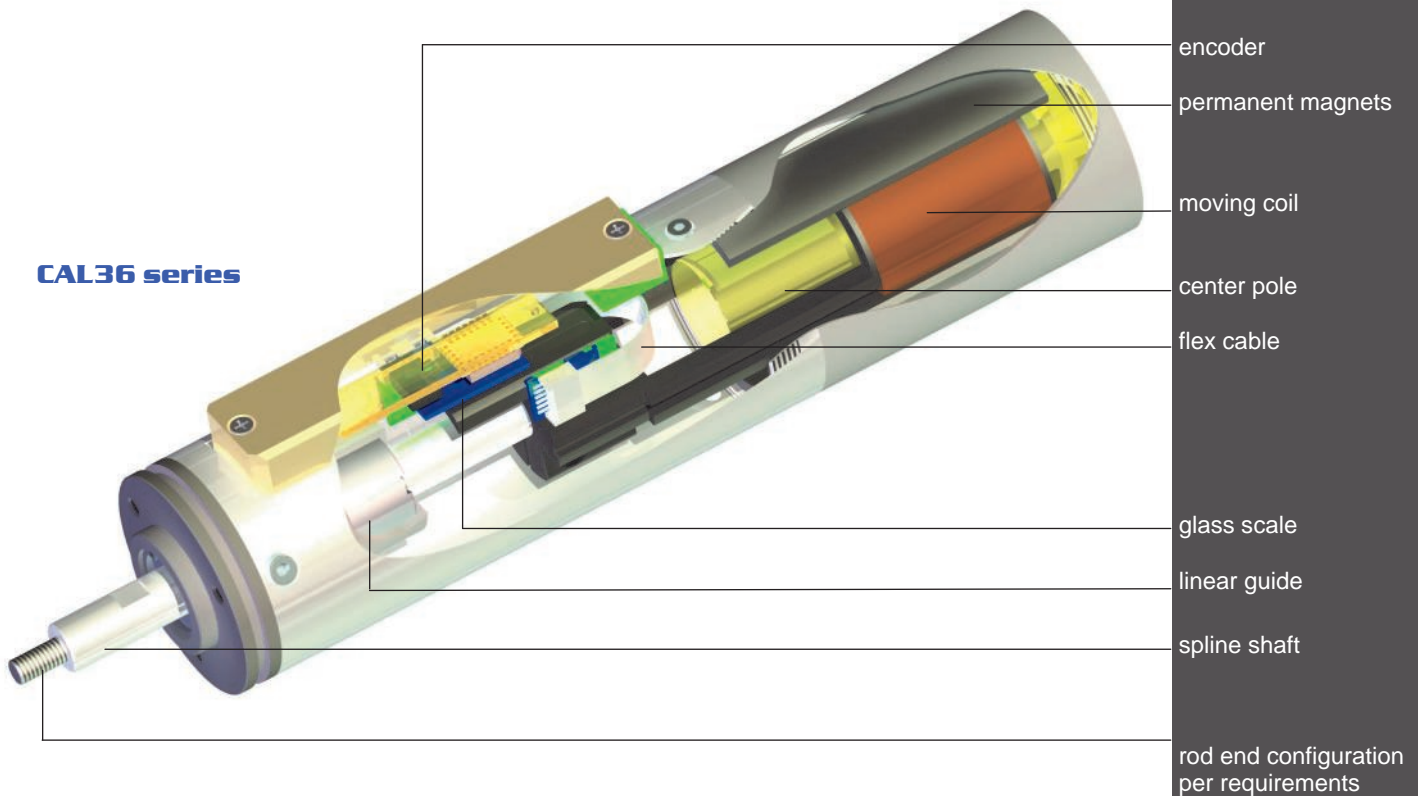

Linear and Linear / Rotary Moving Coil Actuators

Linear:

- Stroke up to 250mm, force up to 500N, position encoder resolution 5 μ m standard, 1 and 0.1 μ m option for most actuators.
- Programmable force, position, acceleration and velocity.

Rotary:

- Multi-turn servo motor, torque up to 4.5Nm, velocity up to 5000 rpm, resolution up to 132,000 increments per revolution.
- Programmable force, position, acceleration and velocity.

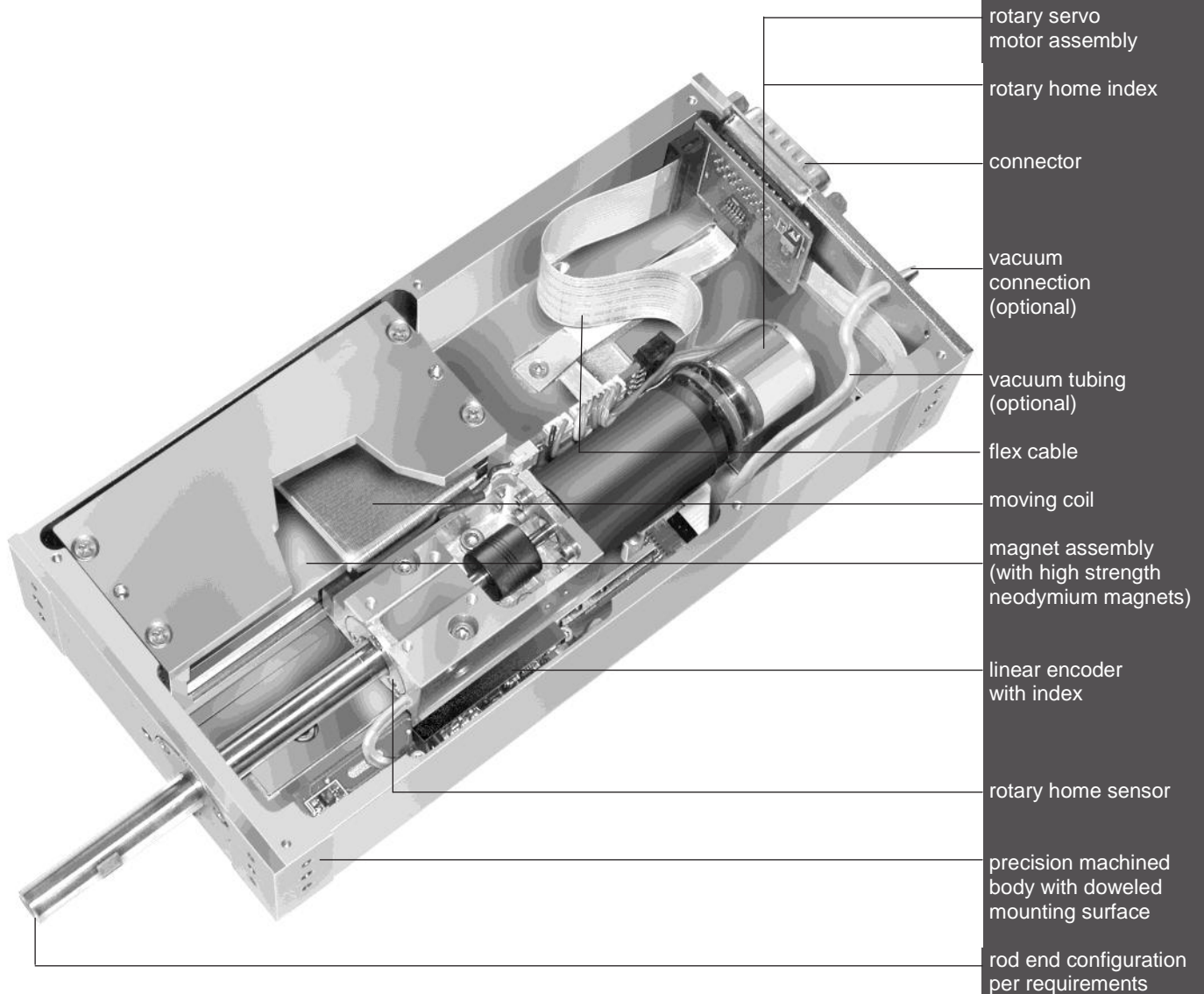

Part Numbering System

	MODEL	SERIES	STROKE	ENCODER VOLT	SHAFT	VACUUM	SPRING	*** Cable	**** Mounting	M O D	
CYLINDER	C A L	3 6	0 2 5								
LINEAR	L A L	3 0 0	0 5 0								
	L C A	2 5	0 1 0								
LINEAR/ ROTARY	L A R	3 5	0 5 0								
SLIDE	L A S	5 5	1 0 0	1							Multi Pole
	L C S	3 0		2							
XY TABLE	L X Y			3							Single Pole
GRIPPER	G R P			4							
				5							
				6							
				7							
				8							
				0							
				1							
				2							
				3							
				5							
					B						
					F						
					M						
					C						
					V						
					S						
					SA						
					SB						
					SC						
					SD						
					SE						
					SF						
										3	
										5	
										A	
										B	

Part Number Examples:

LAS20-010-55

LAS20 linear slide, 10mm stroke, 24volt single coil,
5 micron encoder.

LAL300-050-85-F

LAL300 linear actuator, 50mm stroke, 48volt double coil
5 micron encoder, female rod end.

LAR55-100-75-MS-MOD674

LAR55 linear/rotary actuator, 100mm stroke, 48 volt single coil,
5 micron encoder, male thread, spring, mod 674 specification.

CAL36-015-55-F3A

CAL36 electric cylinder, 36mm dia., 15mm stroke, 24volt single coil,
5 micron encoder, female shaft end, flying lead and front mount

NOTES:

Series will not have leading zeros (e.g. LAL95).

Stroke must include zeros (e.g. 050).

Spring must be specified as full return or counterbalance,
payload and orientation (vertical or horizontal).

* LCA series only
** Check availability
*** CA and LCA series only
**** CA series only

Electric Cylinders - CAL Series

	Voltage [DC]	Size: Dia x L [mm]	Stroke [mm]	Maximum Force [N]	Continuous Force [N]	Force Constance [N/A]	Maximum Current [Amp]	Moving Mass [kg]	Weight [kg]
CAL12-010-5	24	Ø12x112	10	1.5	0.4	1	1.5	0.01	0.08
CAL36-015-5	24	Ø36x145	15	18	7.2	18	1	0.08	0.8
CAL36-015-6	24	Ø36x202	15	30	12	15	2	0.13	1.18
CAL36-015-8	48	Ø36x202	15	41	16.4	18	2.3	0.13	1.18
CAL36-025-5	24	Ø36x155	25	15	6	15	1	0.08	0.95
CAL36-025-6	24	Ø36x212	25	27	10.8	27	2	0.15	1.27
CAL36-050-5	24	Ø36x230	50	12	4.8	12	1	0.095	1.15
CAL75-015-5	24	Ø75x249	15	40	16	31	1.3	0.44	4.8
CAL75-015-7	48	Ø75x249	15	62	24.8	48	1.3	0.44	4.8
CAL75-025-5	24	Ø75x262	25	27	10.8	22	1.3	0.44	5.1
CAL75-025-7	48	Ø75x262	25	53	21.2	44	1.3	0.44	5.1
CAL75-050-5	24	Ø75x283	25	25	10	19	1.3	0.44	5.6
CAL75-050-7	48	Ø75x283	50	40	16	32	1.3	0.44	5.6
CAL75-050-8	48	Ø75x385	50	150	60	33.5	2.7	0.81	8



CAL12



CAL36



CAL75

NOTE: SMAC requires that each CA series unit must be operated at less than suggested duty cycle (%). Please see page 20.

We manufacture actuators to suit our customers' requirements. Please call us if you do not find the right actuator in this list.

Options & Modifications (Consult factory for availability):

Encoder resolutions:	CAL12 series: 1µm standard. 0.1µm optional. CAL36 and CAL75 series: 5µm standard. 0.5µm, 1µm and 0.1µm optional for most units.
Shaft ends:	Male, Female, Blank and Custom
Return spring:	Prevents the shaft from dropping during vertical operation when power is cut.
Vacuum:	Vacuum through the shaft or on the shaft for pick and place applications.
Mount:	Face mount (standard) , foot mount or threaded mount (CAL12 series only)

Linear Actuators - LCA series

	Voltage [DC]	Size: LxWxH [mm]	Stroke [mm]	Maximum Force [N]	Continuous Force [N]	Force Constant [N/A]	Maximum Current [Amp]	Moving Mass [kg]	Weight [kg]
LCA8-010-6	24	50x95x8	10	4	(*)	3.2	1.7	0.025	0.16
LCA8-025-2	24	50x110x8	25	2.6	(*)	2.2	1.3	0.027	0.18
LCA8-050-2	24	50x135x8	50	2.6	(*)	2.2	1.3	0.03	0.22
LCA16-010-6	24	60x110x16	10	6	2.5	4.3	1.5	0.045	0.435
LCA16-010-8	48	60x110x16	10	13	5	6.5	1.5	0.045	0.435
LCA25-010-5	24	55x70x25	10	8	3	6	1.5	0.04	0.27
LCA25-010-6	24	60x130x25	10	16	6	5.5	3	0.085	0.45
LCA25-010-7	48	55x70x25	10	12	5	8	1.5	0.04	0.27
LCA25-010-8	48	60x130x25	10	22	9	8	3	0.085	0.45
LCA25-025-1	24	60x130x25	25	18	7	13	1.6	0.076	0.55
LCA25-025-3	48	60x130x25	25	22	9	14.5	1.6	0.076	0.55
LCA25-025-6	24	60x130x25	25	7.4	2.9	2.5	3	0.076	0.55
LCA25-025-8	48	60x130x25	25	9.2	3.6	3	3	0.076	0.55
LCA25-050-1	24	60x155x25	50	18	7	13	1.6	0.082	TBD
LCA25-050-3	48	60x155x25	50	22	9	14.5	1.6	0.082	TBD
LCA25-100-1	24	60x205x25	100	18	7	13	1.6	0.1	TBD
LCA25-100-3	48	60x205x25	100	22	9	14.5	1.6	0.1	TBD
LCA25-150-1	24	60x258x25	150	18	7	13	1.6	0.12	TBD
LCA25-150-3	48	60x258x25	150	22	9	14.5	1.6	0.12	TBD
LCA25-200-1	24	60x310x25	200	18	7	13	1.6	0.14	TBD
LCA25-200-3	48	60x310x25	200	22	9	14.5	1.6	0.14	TBD
LCA31-010-8	48	44x100x31	12	38	15	8.5	6	0.059	0.55
LCA50-025-7	48	100x125x50	25	50	20	40	1.5	0.335	2.16
LCA50-050-3	48	115x250x50	50	90	36	67	1.7	0.665	TBV
LCA50-050-7	48	100x125x50	50	45	18	30	1.6	0.335	2.58
LCA50-050-8	48	100x215x50	50	85	34	30	3	0.465	4.34
LCA50-100-3	48	115x300x50	100	110	46	68	1.7	0.66	5.7



(*) Consult factory

NOTE: SMAC requires that all units must be operated at less than 40% maximum duty cycle. Please see page 20 or user manual for further explanation on how to calculate duty cycle.

We manufacture actuators to suit our customers' requirements. Please call us if you do not find the right actuator in this list. Linear actuators are also available as linear slides (See page 13)

Options & Modifications (Consult factory for availability):

- Linear encoder resolutions: LCA8 series: 1µm standard. 0.1µm optional.
LCA16, LCA25 and LCA50 series: 5µm standard. 1µm, 0.5µm, and 0.1µm optional for most units.
- Shaft ends: Male, Female, Blank and Custom (check availability of custom option)
- Return spring: Prevents the shaft from dropping during vertical operation when power is cut.
- Vacuum: Vacuum through the shaft or on the shaft for pick and place applications.
- Extended nose bushing: For tighter shaft run-out and higher side load onto the shaft.
- Increase of max. force & acceleration: 48 volt coil and double coil options are available for some units with 24 volt single coil.
- Increase of force accuracy & lifetime: Extra long life linear guide / Low friction linear guide

Linear Actuators - LAL series

	Voltage [DC]	Size: LxWxH [mm]	Stroke [mm]	Maximum Force [N]	Continuous Force [N]	Force Constant [N/A]	Maximum Current [Amp]	Moving Mass [kg]	Weight [kg]
LAL15-015-5	24	120x58x15	15	5	2.7	2.7	1.7	0.05	0.23
LAL20-010-5	24	65x85x20	10	8	5.5	5.5	1.8	0.07	0.3
LAL20-015-5	24	65x115x20	15	7	2.8	5	1.8	0.07	0.34
LAL20-015-6	24	65x115x20	15	12	4.8	5.8	2.3	0.08	0.34
LAL20-025-5	24	65x115x20	25	5.4	2	3.4	2	0.08	0.36
LAL20-025-7	48	65x115x20	25	9.3	5	5	1.8	0.06	0.36
LAL35-025-6	24	135x90x35	25	31.5	12.6	15.5	2.9	0.19	1.06
LAL35-025-7	48	135x90x35	25	18	7	10	1.3	0.12	0.95
LAL35-050-5	24	135x90x35	50	10	4	7	1.6	0.13	1.1
LAL35-050-7	48	135x90x35	50	12.5	5	10	1.3	0.13	1.1
LAL35-100-5	24	135x90x35	100	6	2.4	3.5	1.6	0.1	1.7
LAL55-050-5	24	250x110x55	50	25	10	19	1.3	0.3	3
LAL55-050-7	48	250x110x55	50	40	16	24.5	1.8	0.3	3
LAL55-100-5	24	250x110x55	100	16	6.4	13	1.3	0.3	3.8
LAL55-100-7	48	250x110x55	100	25	10	17	1.8	0.3	3.8
LAL55-150-5	24	250x110x55	150	13	5	10	1.3	0.4	4.5
LAL55-150-7	48	250x110x55	150	19.5	8	12.5	1.8	0.4	4.5
LAL95-015-7	48	90x70x95	15	84	33	53	1.7	0.25	2.2
LAL95-015-8	48	147x70x95	15	185	74	58	3.2	0.5	3
LAL95-025-8	48	180x70x95	25	162	65	52	3.1	0.58	3.75
LAL95-050-7	48	147x70x95	50	65	26	41	1.7	0.25	3
LAL300-050-8	48	210x85x120	50	202	80	86	3	0.8	8.8
LAL500-025-8	48	300x140x200	25	500	200	166	3	1.6	26.5
LAL500-050-8	48	300x140x200	50	500	200	100	4	1.6	26.5



LAL15



LAL20



LAL35



LAL55



LAL95



LAL300



LAL500

NOTE: SMAC requires that all units must be operated at less than 40% maximum duty cycle. Please see page 20 or user manual for further explanation on how to calculate duty cycle.

We manufacture actuators to suit our customers' requirements. Please call us if you do not find the right actuator in this list. Linear actuators are also available as linear slides (See page 14)

Options & Modifications (Consult factory for availability):

- Linear encoder resolutions: 5µm standard, 1µm, 0.5µm and 0.1µm optional for most units. Consult factory for availability.
- Shaft ends: Male, Female, Blank and Custom (check availability of custom option)
- Return spring: Prevents the shaft from dropping during vertical operation when power is cut.
- Vacuum: Vacuum through the shaft or on the shaft for pick and place applications.
- Extended nose bushing: For tighter shaft run-out and higher side load onto the shaft.
- Increase of max. force & acceleration: 48 volt coil and double coil options are available for some units with 24 volt single coil.
- Increase of force accuracy & lifetime: Extra long life linear guide / Low friction linear guide

Specifications subject to change.

Linear & Rotary Actuators - LAR Series

	Voltage [DC]	Size: LxWxH [mm]	Stroke [mm]	Maximum Force [N]	Continuous Force [N]	Force Constant [N/A]	Maximum Current [Amp]	Moving Mass [kg]	Weight [kg]	Maximum Torque* [Nm]	Rotary type	Rotary Encoder Resolution	Velocity* [rpm]
LAR15-015-5	24	120x58x15	15	5	2	2.7	1.5	0.095	0.25	0.008	direct	20K	500
LAR20-015-5	24	115x65x20	15	7	2.8	5	1.8	0.09	0.41	0.008		20K	500
LAR31-030-5	24	140x80x34.7	30	11	4.4	7	1.5	0.19	0.84	0.06		40960	2000
LAR31-050-1	24	175x78.8x36.4	50	20	8	8.5	3.5	0.25	1	0.06		40960	2000
LAR35-025-5	24	190x90x35	25	12	4.8	7	1.6	0.14	1.2	0.085		20K	500 - 5000
LAR35-050-5	24	190x90x35	50	10	4	7	1.6	0.29	1.4	0.085		20K	500 - 5000
LAR51-050-1	48	96x180x54	50	35	14	11.5	3	0.35	2.1	0.14		40960	2000
LAR55-050-5	24	250x110x55	50	25	10	19	1.6	0.5	3.1	0.2 - 2.5	direct or gear box	2K-28K	500 - 5000
LAR55-050-7	48	250x110x55	50	40	16	27	1.8	0.31	2.8	0.2 - 2.5		2K-28K	500 - 5000
LAR55-100-5	24	250x110x55	100	16	6.4	13	1.6	0.5	3.85	0.2 - 2.5		2K-28K	500 - 5000
LAR55-100-7	48	250x110x55	100	25	10	13	2	0.5	3.85	0.2 - 2.5		2K-28K	500 - 5000
LAR95-015-7	48	304x90x115	15	84	33	53	1.7	0.9	3.5	0.2 - 4.5		2K-132K	75 - 5000
LAR95-050-7	48	304x90x115	50	65	26	41	1.7	0.9	4.2	0.2 - 4.5		2K-132K	75 - 5000
LAR300-050-8	48	284x85x160	50	202	80	86	3	1	9.5	0.2 - 4.5		2K-132K	75 - 5000



LAR15



LAR20



LAR31



LAR35



LAR55



LAR95



LAR300

NOTE: SMAC requires that all units must be operated at less than 40% maximum duty cycle. Please see page 20 or user manual for further explanation on how to calculate duty cycle.

We manufacture actuators to suit our customers' requirements. Please call us if you do not find the right actuator in this list.

Options & Modifications (Consult factory for availability):

Linear encoder resolutions:	5µm standard, 1µm, 0.5µm and 0.1µm optional for most units. Consult factory for availability.
Shaft ends:	Male, Female, Blank and Custom (check availability of custom option)
Return spring:	Prevents the shaft from dropping during vertical operation when power is cut.
Vacuum:	For pick and place applications
Extended nose bushing:	For tighter shaft run-out and higher side load onto the shaft.
Increase of max. force and acceleration:	48 volt coil and double coil options are available for some units with 24 volt single coil.
Increase of torque/gear ratio:	Alternative geared motors are available for some units.
Rotary encoder resolution:	Consult factory for higher resolution.
Increase of force accuracy & lifetime:	Extra long life linear guide, Low friction linear guide

* Torque and velocity can vary based on your specific application.

Linear Slides - LCS series

	Voltage [DC]	Size: LxWxH [mm]	Stroke [mm]	Maximum Force [N]	Continuous Force [N]	Force Constant [N/A]	Maximum Current [Amp]	Moving Mass [kg]	Weight [kg]
LCS8-010-6	24	50x95x8	10	4	(*)	3.2	1.7	0.025	0.16
LCS8-025-2	24	50x110x8	25	2.6	(*)	2.2	1.3	0.025	0.17
LCS8-050-2	24	50x135x8	50	2.6	(*)	2.2	1.3	0.025	0.21
LCS25-010-5	24	55x70x25	10	8	3	6	1.5	0.04	0.27
LCS25-010-6	24	60x130x25	10	16	6	5.5	3	0.085	0.45
LCS25-010-7	48	55x70x25	10	12	4.8	8	1.5	0.04	0.27
LCS25-010-8	48	60x130x25	10	22	8	8	3	0.085	0.45
LCS25-025-1	24	60x130x25	25	18	7	13	1.6	0.08	0.55
LCS25-025-3	48	60x130x25	25	22	8	14.5	1.6	0.08	0.55
LCS25-025-6	24	60x130x25	25	7.4	2.9	2.5	3	0.08	0.55
LCS25-025-8	48	60x130x25	25	9.2	3.6	3	3	0.08	0.55
LCS25-050-1	24	60x155x25	50	18	7	13	1.6	0.08	0.616
LCS25-050-3	48	60x155x25	50	22	8.8	14.5	1.6	0.08	0.616
LCS25-100-1	24	60x205x25	100	18	7	13	1.6	0.08	0.808
LCS25-100-3	48	60x205x25	100	22	8.8	14.5	1.6	0.08	0.808
LCS25-150-1	24	60x258x25	150	18	7	13	1.6	0.08	TBD
LCS25-150-3	48	60x258x25	150	22	8.8	14.5	1.6	0.08	TBD
LCS25-200-1	24	60x310x25	200	18	7	13	1.6	0.08	1.183
LCS25-200-3	48	60x310x25	200	22	8.8	14.5	1.6	0.08	1.183
LCS30-010-5	24	30x50x30	10	4	1.6	2	1.5	0.03	0.17
LCS30-010-7	48	30x50x30	10	6	2.4	4	1.5	0.03	0.17
LCS50-025-7	48	100x125x50	25	50	20	40	1.5	0.296	2.118
LCS50-050-7	48	100x125x50	50	30	12	18	1.6	0.33	2.57
LCS50-100-3	48	115x300x50	100	90	36	67	1.7	0.885	5.6
LCS50-250-3	48	115x450x50	250	110	36	65	1.7	0.885	14



LCS8



LCS25



LCS30



LCS50

(*) Consult factory

NOTE: SMAC requires that all units must be operated at less than 40% maximum duty cycle. Please see page 20 or user manual for further explanation on how to calculate duty cycle.

We manufacture actuators to suit our customers' requirements. Please call us if you do not find the right actuator in this list.

Options & Modifications (Consult factory for availability):

- Linear encoder resolutions: LCS8 series: 1µm standard. 0.1µm optional.
LCS25 and LCS50 series: 5µm standard. 0.5µm, 1µm and 0.1µm optional for most units.
- Return spring: Prevents the shaft from dropping during vertical operation when power is cut.
- Increase of maximum force & acceleration: 48 volt coil and double coil options are available for some units with 24 volt single coil.
- Increase of force accuracy & lifetime: Extra long life linear guide, Low friction linear guide

Specifications subject to change.

Linear Slides - LAS series

	Voltage [DC]	Size: LxWxH [mm]	Stroke [mm]	Maximum Force [N]	Continuous Force [N]	Force Constant [N/A]	Max Current [Amp]	Moving Mass [kg]	Weight [kg]
LAS15-015-5	24	120x58x15	15	5	2.7	2.7	1.7	0.05	0.23
LAS20-010-5	24	85x65x20	10	8	3.2	5.5	1.8	0.07	0.3
LAS20-015-5	24	65x115x20	15	7	2.8	5	1.8	0.07	0.34
LAS20-025-5	24	85x65x20	25	5.5	2	2.8	2	0.07	0.34
LAS20W-025-6	24	75x135x21	25	19	7.8	7.8	3	0.122	0.54
LAS35-025-6	24	135x90x35	25	31.5	12.6	15.5	2.9	0.19	1.06
LAS35-025-7	48	150x90x35	25	18	7	10	1.3	0.15	0.95
LAS35-050-5	24	135x90x35	50	10	4	7	1.6	0.13	1.1
LAS35-050-7	48	135x90x35	50	12.5	5	10	1.3	0.13	1.1
LAS35-100-5	24	135x90x35	100	6	2.4	3.5	1.6	0.13	1.7
LAS35-100-7	48	135x90x35	100	7.5	3	5	1.6	0.1	1.3
LAS55-050-5	24	250x110x55	50	25	10	19	1.3	0.3	3
LAS55-050-7	48	250x110x55	50	40	16	24.5	1.8	0.31	3
LAS55-100-5	24	250x110x55	100	16	6.4	13	1.3	0.3	3.8
LAS55-100-7	48	250x110x55	100	25	10	19	1.8	0.31	3.8
LAS55-150-5	24	250x110x55	150	13	5	10	1.3	0.4	4.5
LAS55-150-7	48	250x110x55	150	19.5	8	13	1.8	0.31	4.58
LAS95-015-7	48	90x70x95	15	84	33	53	1.7	0.25	2.1
LAS95-015-8	48	147x70x95	15	185	74	58	3.2	0.5	4
LAS95-025-8	48	180x70x95	25	162	65	52	3.1	0.5	3.78
LAS95-050-7	48	147x70x95	50	65	26	41	1.7	0.25	3
LAS300-050-8	48	210x85x120	50	202	80	86	3	0.8	8.8



LAS15



LAS20



LAS35



LAS55



LAS95



LAS300

NOTE: SMAC requires that all units must be operated at less than 40% maximum duty cycle. Please see page 20 or user manual for further explanation on how to calculate duty cycle.

We manufacture actuators to suit our customers' requirements. Please call us if you do not find the right actuator in this list.

Options & Modifications (Consult factory for availability):

Linear encoder resolutions: 5µm standard, 1µm, 0.5µm and 0.1µm optional for most units. Consult factory for availability.

Return spring: Prevents the shaft from dropping during vertical operation when power is cut.

Increase of maximum force & acceleration: 48 volt coil and double coil options are available for some units with 24 volt single coil.

Increase of force accuracy & lifetime: Extra long life linear guide, Low friction linear guide

Grippers

	Voltage [DC]	Size: LxWxH [mm]	Stroke per Axis [mm]	Axis 1				Axis 2				Maximum Current [Amp]	Weight [kg]	Maximum Opening
				Maximum Force [N]	Continuous Force [N]	Force Constant [N/A]	Moving Mass [kg]	Maximum Force [N]	Continuous Force [N]	Force Constant [N/A]	Moving Mass [kg]			
GRP20-010-5	24	80x90x23	5	8	3.2	5.5	0.065	8	3.2	5.5	0.065	1.8	0.5	10
GRP35-030-5	24	93x110x38	15	25	10	17	0.1	25	10	17	0.1	1.5	1.5	30
GRP35-030-7	48	93x110x38	15	26	10	13	0.1	26	10	13	0.1	1.9	1.5	30
GRP50-030-5	24	90x125x55	15	35	14	25	0.15	35	14	25	0.15	1.5	2.5	30
GRP50-030-7	48	90x125x55	15	45	18	22.5	0.15	45	18	22.5	0.15	1.5	2.5	30



GRP20



GRP35



GRP50

NOTE: SMAC requires that all units must be operated at less than 40% maximum duty cycle. Please see page 20 or user manual for further explanation on how to calculate.

We manufacture actuators to suit our customers' requirements. Please call us if you do not find the right actuator in this list.

Options & Modifications (Consult factory for availability):

- Linear encoder resolutions: GRP20: 1µm standard and 0.1µm optional.
GRP35 and GRP50: 5µm standard, 1µm, 0.5µm and 0.1µm optional.
- Increase of the maximum force & acceleration: 48 volt coil and double coil options are available for some units with 24 volt single coil.
- Increase of the force accuracy & lifetime: Extra long life linear guide
Low friction linear guide

XY Stages

	Voltage [DC]	Size: LxWxH [mm]	Stroke per Axis [mm]	Axis 1				Axis 2				Maximum Current [Amp]	Weight [kg]
				Maximum Force [N]	Continuous Force [N]	Force Constant [N/A]	Moving Mass [kg]	Maximum Force [N]	Continuous Force [N]	Force Constant [N/A]	Moving Mass [kg]		
LXY15-015-8	48	111x112x86	15	22	11	13	0.13	25	12	12	0.22	2.2	1.65
LXY25-025-8	48	125x125x65	25	42	17	14	0.19	42	17	14	1.5	3	3.2



LXY15



LXY25

NOTE: SMAC requires that all units must be operated at less than 40% maximum duty cycle. Please see page 20 or user manual for further explanation on how to calculate.

We manufacture actuators to suit our customers' requirements. Please call us if you do not find the right actuator in this list.

Options & Modifications (Consult factory for availability):

- Linear encoder resolutions: 5µm standard, 1µm, 0.5µm and 0.1µm optional for most units. Consult factory for availability.
- Increase of maximum force & acceleration: 48 volt coil and double coil options are available for some units with 24 volt single coil.

Multi-Axis Systems

SMAC is pleased to introduce its range of multi-axis control solutions. These systems are able to learn and follow a 3D contour or motion path, with a high degree of speed, precision, accuracy and repeatability. All combinations of SMAC actuators can be used: linear, linear/rotary, linear slide, and XY stage axis.

Ideal applications are measuring and testing (QC), dispensing (Bonding), machining (CNC), scoring and cutting, to name a few. SMAC multi-axis 3D systems are unique - they enable total programmability of speed, position and force all at the same time with an exceptional degree of accuracy and repeatability. SMAC multi-axis systems offer a wide range of solutions with a number of highly flexible control interfaces.

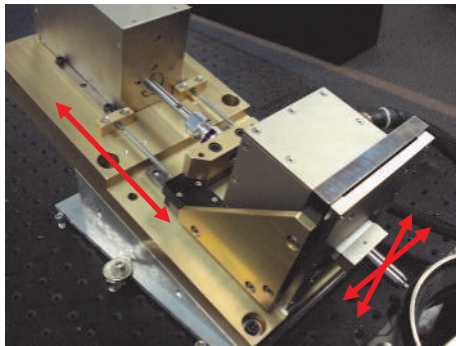

LXY15 & LAL95

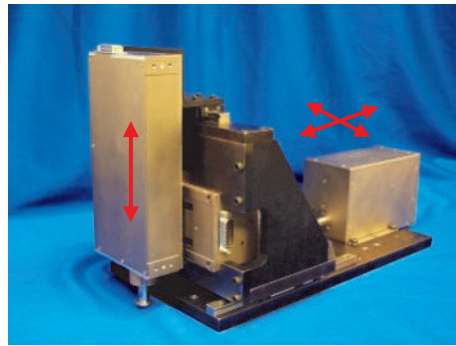

LAL35, LAL95 & LAS95

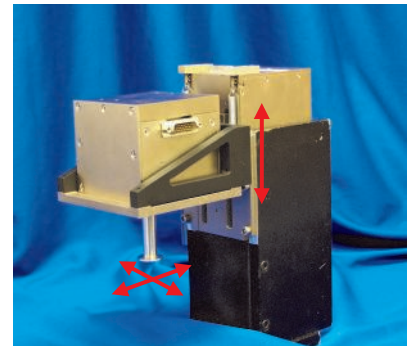

LXY15 & LAS95

Controllers / Amplifiers

SMAC supplies a range of single and multi axis controllers together with stand alone amplifiers and stepper driven driver. Controllers are programmed by mnemonic type command instructions via an RS-232 interface into NVRAM. They require no supplementary software.



LCC-10 (LCC-11)

Single axis controller
Built-in amplifier
Single phase/3 phase brushless motor
Easy expansion to multi-axis

Mode:

- Position
- Velocity
- Force

24-48VDC
2amp cont., 4amp peak
4 TTL input/output,
1 analog output, 10 bit standard
(16 bit optional as model # LCC-11)
RS232 and CAN bus interface
Can be run as drive only



LAC-1

Single axis controller
Built-in amplifier
Single phase brush motor

Mode:

- Position
- Velocity
- Force

12-48VDC
3amp cont., 6amp peak
8TTL input/output
3 analog input
RS232 interface



LAC-26

2 axis controller
Built-in amplifier
1st axis single phase brush
2nd axis brush/brushless motor

Mode:

- Position
- Velocity
- Force
- Gearing

12-48VDC
3amp cont. per axis, 6amp peak per axis
Independent or coordinated
2 axis motion
3 opto-isolated input, 2 opto-isolated output
1 analog output/axis
RS232 interface



LAC-25

2 axis controller
Built-in amplifier
Single phase brush motor

Mode:

- Position
- Velocity
- Force
- Gearing

12-48VDC
3amp cont. per axis, 6amp peak per axis
Independent or coordinated
2 axis motion
4 opto-isolated input/output
1 analog output/axis
RS232 interface



LAC-45

4 axis controller
Built-in amplifier
Single phase brush motor

Mode:

- Position
- Velocity
- Force
- Gearing

12-48VDC
3amp cont. per axis, 6amp peak per axis
Independent or coordinated 4 axis motion
8 opto-isolated input/output
1 analog output/axis
RS232 interface



MAAC4-7

4 axis brushed/ brushless controller
Integrated high end amplifier
Advanced math capability
Circular interpolation
Teach path function

24-48VDC
6amp cont. per axis, 10amp peak per axis
8 TTL input, 7 TTL output
RS-232 and Ethernet Interface



LAA-5

Single axis amplifier

24-48VDC
3amp cont., 6amp peak
+/- 10 Volt command input
3 amp output



LAD-1

Smart Driver for single axis stepper
input to servo output

24-48VDC
RS232 Interface



MIOE-8/8

Expansive I/O module for LAC-1, LAC-25
and LAC-45

24-48VDC
8 opto-isolated input/output

Cables

Why Use SMAC Cables?

SMAC actuators are used in numerous high speed, high cycle applications and are guaranteed for millions of cycles. For this reason, it is imperative that the cables used to connect with our actuators are capable of similar arduous duty cycles and life span. Only cables manufactured by SMAC can be guaranteed to meet the rigorous standards required during use. Many years of experience has taught us that cheaper third party cables simply are not up to the task required. They are, in fact, one the most common causes of all the technical problems experienced by our customers.

Actuator	Single Axis Controller		Dual Axis Controller		Amplifier	Smart Driver	
	LAC-1	LCC-10(11)	LAC-26	LAC-25	LAA-5	LAD-1	
CAL	CAH-LOD26-03	CAH-LOD26-03			CAH-LAD26-03	CAH-LSD26-03	No cable required for flying lead option
2x CAL				CAH-LTD-03			No cable required for flying lead option
LCA(S) single/ double coil	CAH-LOD26-03	CAH-LOD26-03			CAH-LAD26-03	CAH-LSD26-03	No cable required for flying lead option
LCA(S) 6 coil		MAH-LOD26-03					No cable required for flying lead option
LAL15*/LAL20/ LAL35/LAL95	LAH-LOD26-03	LAH-LOD26-03			LAH-LAD26-03	LAH-LSD26-03	* Also need LAH-PT30-26
LAL55/LAL300/ LAL500	LAH-LOD-03	LAH-LOD-03			LAH-LAD-03	LAH-LSD-03	
LAR15*/LAR20/ LAR35				LAH-RTD26-03	LAH-RAD26-03	LAH-RSD26-03	* Also need LAH-PT30-26
LAR31			MAH-RTD26-03				
LAR55 / LAR95 / LAR300				LAH-RTD-03	LAH-RAD-03	LAH-RSD-03	
2 x LAL15*/ LAL20/LAL35 / LAL95				LAH-LTD26-03			* Also need LAH-PT30-26
2 x LAL55/ LAL300/ LAL500				LAH-LTD-03			
GRP20				LAH-RTD26-03	LAH-RAD26-03		
GRP35				LAH-RTD26-03	LAH-RAD26-03		
GRP50				LAH-RTD26-03	LAH-RAD26-03		
LXY15				LAH-GRP-03	LAA-GRP26-03		
LXY25				LAH-GRP-03	LAA-GRP26-03		

All cables are 3m standard, optional 10m length is available. (Consult factory for other length.) Superflex is available as an option. Suitable for robotic applications.

*1 Requires LAH-PT30-25 (Jumper to 25 pin cable) or LAH-PT30-26 (Jumper to 26 pin cable) as supplement.

*2 Old type of GRP50 requires LAH-GRP26-03 cable.

System Configuration

LCA & LA Series

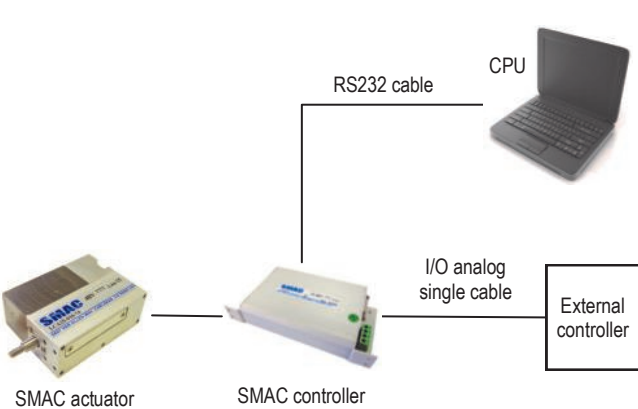

Configuration with SMAC Controllers

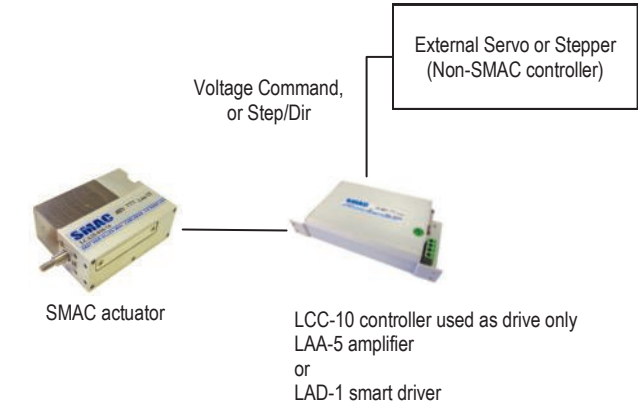

Configuration with Non-SMAC Controllers

CAL Series

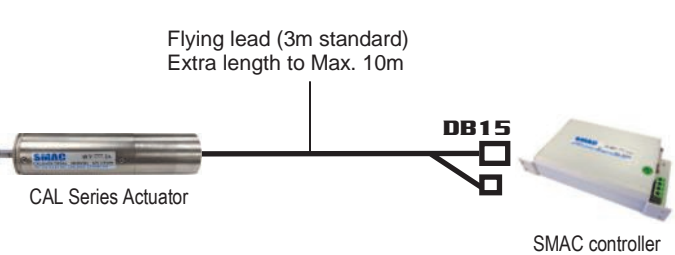

Configuration for Flying Lead Cable

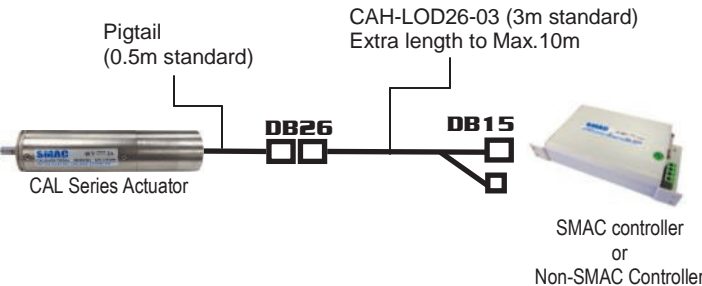

Configuration for Pigtail Cable

Installation Guideline

Duty cycle

SMAC requires that all units must be operated at less than 40% maximum duty cycle.

$\% \text{ of maximum force applied} \times \% \text{ of cycle time it is applied} = \% \text{ duty cycle}$

For example:

- 100% force x 40% of cycle time = 40% duty cycle.
- 60% force x 50% of cycle time = 30% duty cycle.
- 40% force x 100% of cycle time = 40% duty cycle.

Recommendation from SMAC is that the duty cycle must not be exceeded over a one second time period.

NOTE: Failure to observe this duty cycle recommendation may result in the actuator sustaining damage through overloading. Overloading will overheat the coil and may cause deformation or an impact on the magnet housing.

Continuous Force

Peak force applied for duration shorter than 0.4 sec. in one second interval.

(force mode): 40% of peak force, continuous

Force Mode

The specified current may be applied continuously to generate the desired force. However, the recommended continuous force limit should be set in the control program.

In vertical operation, the actuator rod will drop when power is cut off. The rod in a lowered position may be damaged by other moving parts in the machine. A return spring (optional feature) will keep the rod raised. A safety lock-out should be installed in the machine program to confirm the rod location before another interfering component can be moved.

SMAC actuators are equipped with these safety features:

- Limit switches: indicate end-of-stroke
- Index line/home position: used to monitor absolute position
- Breakaway shaft (optional)

Safety Considerations

Unintentional full force may be applied continuously under the following conditions:

- missed target position
- excessive friction
- equipment malfunction, i.e. jam

If left undetected, this can cause destruction of the coil in some units. A servo program should perform the following checks regularly:

- Re-home: to assure target position has not shifted beyond end of stroke
- Time-outs: to shut power down within 10 seconds of error detection
- Following Error Limits: software safety
- Check limit switches
- Check temperature sensor

Mounting

If the actuator is mounted vertically, the shaft drops down when the actuator is powerless. It is possible that other moving parts of the machine may damage the actuator at this position.

A return spring would hold the actuator in an upper position when it is powerless.

A safety function in your machine should check the actuator's current position before other components may move into the working area of the actuator.

Individual Modifications

Many of our standard actuators listed on previous pages are compatible with both add-on options and modifications. In addition to the standard vacuum and spring option SMAC can offer the following modifications subject to approval by the factory.

Linear Guide Options

Increased rigidity and side load tolerance can be gained by using a higher specification “wide guide”. Additionally, in force sensitive applications we can fit a low friction guide.

Double Coil

Integrating an extra coil can enhance both force and acceleration.

Custom Nose-Bush

An extended nose bush with increased side load tolerance are available on many models. We can also offer scraper and wiper seals around the shaft to protect the bearings from excessive wear in harsh environments.

Custom Shafts

In addition to the standard male/female rod ends we can also offer options such as “breakaway” shafts and custom shaft diameters.

10µm T.I.R.

Total indicator run-out under 10µm is available on several linear/rotary models.

Rotary

Increased torque/gear ratio can be gained by using alternative geared motors or direct drive motors.

Higher rotary encoder resolutions are optional. Please consult factory for availability.

If a longer life rotary is required, then we can fit a brushless rotary motor.

Flying Lead

Instead of the standard chassis connector we can offer a flying lead option. The flying lead is standard for all the CA and LCA series actuators.

Cable Options

Whenever an SMAC actuator is mounted to any 3rd party device such as a gantry or multi-axis robot, SMAC strongly recommends that a superflex cable is used. Cable lengths with a standard of 3 meters up to a maximum of 10 meters can be offered.



Select Your Actuator

In order to select the correct actuator for your application following parameters should be known.

Machine Function:	Mount Details:
Space Available [mm]: x= y= z=	Mount surface: Axis side surface / Actuator side surface
Orientation: Horizontal / Vertical rod down / Vertical rod up	Environment: Debris / Dust / Vapor / Temperature / Harsh Cleaning Chemicals

Specifications

Linear	Rotary
Stroke [mm]:	Degree of Rotation:
Max. Velocity:	Max. Rot. Velocity:
Min. Velocity:	Min. Rot. Velocity:
Max. Acceleration:	Max. Rot Acceleration:
Max Force [N]: Continuous force [N]:	Max Torque:
Force Resolution [N]:	Torque Resolution:
Force Repeatability [N]:	Torque Repeatability:
Encoder Resolution [µm]: 5 / 1 / 0.1 / other ()	Encoder Resolution
Repeatability [µm]:	Repeatability:
Cycles/sec:	Cycles/sec:
Expected Cycle Life:	Expected Cycle Life:

Rod

Moving part: Rod / Slide	Rod Length (Full Retract) [mm]:	Tip: Male / Female / Blank / Custom
Material requirement:	Vacuum through shaft: Yes / No	Thread of shaft: Standard / M

Special Features

Plating: Standard / Black anodized	Cable: Standard / Superflex	Spring: Full return / Counter balance	Linear Guide: Standard / Long life
---------------------------------------	--------------------------------	--	---------------------------------------

Controller or Amplifier

Location: Built In / External at ... [m]	Cable: Standard / flying lead	I/O: Number and TTL / 24V	Smart Driver: Yes / No
---	----------------------------------	------------------------------	---------------------------

Payload

Weight [gram]:	Size: (LxWxH)	Inertia:
Shape:	Relation to rod/slide: Fixed / Push only / Other	Remarks:

Sample Applications

Switch Test

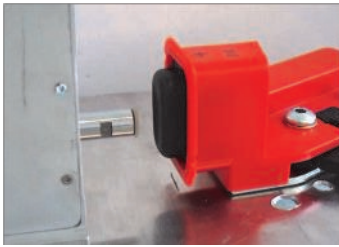

Application Examples

- Automotive switch test
- Cell phone keypads, membrane keypads
- Touch screens
- Valves, sensors and relays
- PC Keyboards, ATM keypads
- Springs, door latches, etc...

The SMAC Advantage

- Verify hysteresis and switch differential
- Accurate simulation of human motion profiles
- Combined force and position measurement
- High speed life testing
- 1,000,000 cycles in 8 hours
- QA reporting functions to verify 100% test

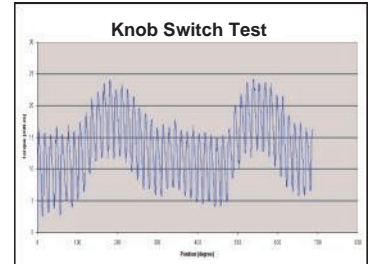
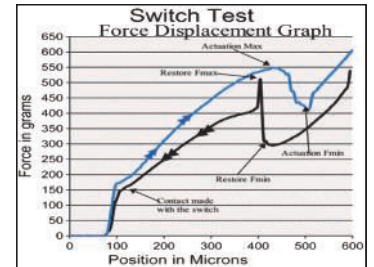

100% Automated Thread Check

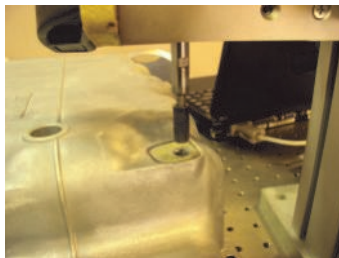

Verification of:

- Oversized / undersized thread
- Number of threads
- Cross thread
- Thread depth
- No thread or dislocated thread
- Pitch measurement
- Shallow / blocked hole

Increase of torque/gear ratio or higher rotary encoder resolutions are available.

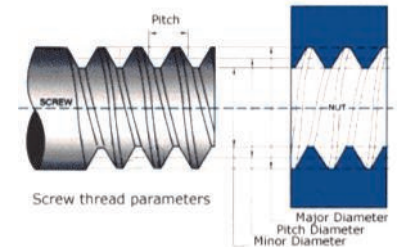

Measuring, Bore Gauging and Groove Inspection

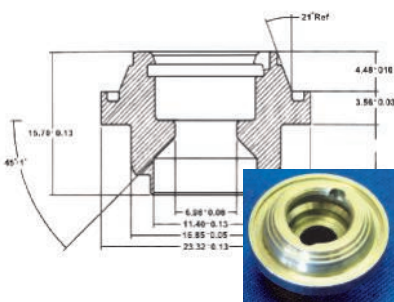

- Airbag components
- Fuel Injector Plug
- Assembly part inside the fuel injector
- XYZ-Mini CMM
- Internal and External Diameter Gauging
- Height Gauging
- Thickness Gauging
- Multiple Point Gauging

Resolution: 5µm (0.0002 inch) to 0.05µm (1.968x10⁻⁷ inch)



- Verifying the depth and diameter of 50µm x 50µm small pockets in a drum for cigarette manufacturing.

Problem:

The previous inspection system included a vision system that measured the diameter of each hole but not the depth. The depth could only be verified by manual spot checks.

SMAC Advantage:

- Precision & contact measuring; the previous system could only measure diameter, but not the depth.
- Fully automate the verification process

Pick & Place

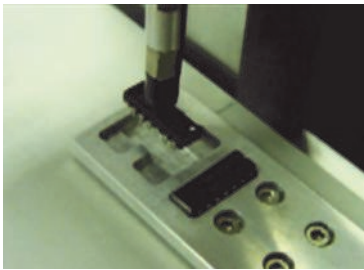
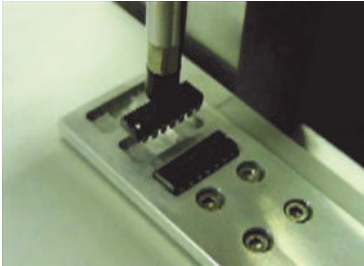

Problem:

- Different pick up height due to mechanical tolerances
- Low throughput of the machine
- Position accuracy – linear and rotary
- Constant force for positioning needed

SMAC Solution:

- Finding the chip surface with the Soft-Land function to avoid damages on the parts
- High speed positioning with a direct drive system
- High resolution positioning up to 0.1 micron
- Up to 50000 counts/revolution - 0.007 degrees
- Controlled precise force
- Shaft run-out 20µm standard. (>10micron option)
- Accurate repeatable positioning at +/- 2 encoder counts
- Programmable force/torque, position and velocity in all axes

Pick & Place Application Examples

- Die bonding
- Smart Card (IC chip mounting)
- Gauging & sorting parts
- Handling small and fragile components

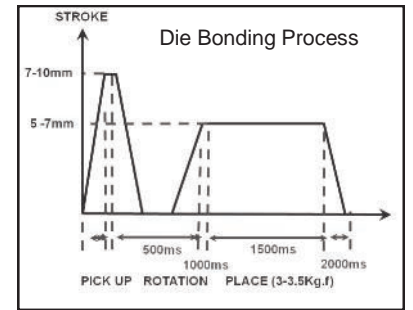

Tapping

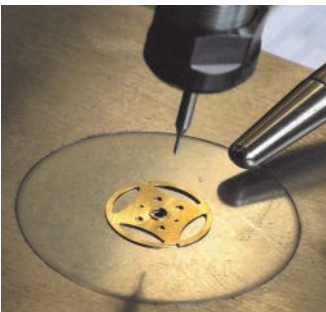

Application

0.38mm Diameter Smart Tapping for a watch manufacture by using LAR35-050-55F
The diameter of the part is about 3.5mm and the hole to tap is about 0.38mm.

Key Features

- Precise force control
- Soft-Land capability
- Precise position control
- Verify thread as the part being tapped.

Screw Driver



Application image with a LAR31 series linear rotary actuator

Application

Simplifying the disc drive assembly system by replacing three devices with one linear rotary actuator.

Problem:

- Difficult to keep precise height alignment at pick and place locations.
- The manual tuning since the end of stroke is a physical adjustment and not programmable.
- The rotary axis is not able to determine position or the linear movement, thus neither the pitch, the number of rotations nor the first thread CCW can be confirmed.
- The cost of the combination, an electric screw driver attached with 2 pneumatic slide, can run up to US\$10,000.

The SMAC Advantage

- SMAC linear rotary electric actuator is an all in one, off the shelf solution.
- A long stroke with fast approach.
- Soft-Landing function at both linear and rotary positions.
- Constant accurate force control while threading.
- Monitoring the torque and pitch verification: Good, shallow, cross, or no threads as well as the precision of the thread are detected through linear position feedback.
- SMAC provides this at 50% less the cost of the previous method.

Packaging



- **Cup Dispensing** - High speed dispensing at **400+ per minute**. High speed, longer life and quiet operation.
- **Bottle Filling:** Excellent flexibility in motion profile and speed of the filling process based upon the material and container size.
- **De-blister:** Automates dispensing of tablets gently from foil and plastic containers. Key points of using SMAC actuators are long life, speed, force, and stroke control, along with quiet operation. Pills are not damaged and stay in recovery container due to force control. Zero compressed air required.
- **Bottle Rejecting, Diverting, and Multi-lane Sorting:** SMAC can reject or divert one container only at line speeds over 1200 containers/minute. Movement of container is smooth, fast, and gentle with unique "soft land" feature. Container will not tip over because of force and velocity control.
- **Efficient Liquid Nitrogen Dosing** - SMAC's unique Soft-Land function prevents damage to the valve when closing which increased valve's life time. This will increase uptime and make the end user more profitable.
- **High Speed on the Fly Labeling:** The label applicator (SMAC actuator) matches the speed of the conveyor as the product comes through. Adjustable speed and height for the different kind of products and then Soft-Land with controlled force.
- **Capping of Bottles:** Cap rotates to engage slot. Detect and report no/obstructed nozzle. Adjust force and torque, show the different quality check capabilities such as cap height, torque limit, force required to press in, and even check the clicks on child proof caps.
- **Parts Feeding:** 50,000 cycles/hour, 24/7 operation.

Medical & Bio-Science



- Scanning 1000 micro machined posts looking for cancer cells. Achieved improving the process time from 8 hours to 15 minutes.
- Precisely moving a lens for the microscope for fine focusing. Achieved 10% cost down and >4 times faster processing speed.
- Pull test on medical stent used in Catheters
- Automated screwing caps on a syringe
- Catheter Tube Welding
- Push/Pull testing of Hypodermic Needles
- Measuring cells height in two conditions, dry and saturated.
- Measuring the amount of wear on a knee replacement plate over x amount of time.
- Medical catheter assembly
- Soft contact lens moulding

Glass

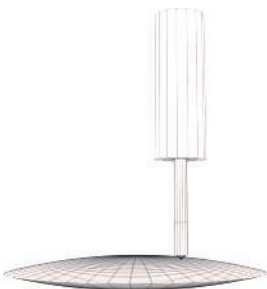

Measuring Thickness of Thin Flexible Glass

Problem: Accuracy of the current air cylinder, LVDT and force control system.

Solution: The customer used the Soft-Land feature of the SMAC LAL20 in conjunction with a load cell mounted on the rod of the SMAC actuator. The LAL20 is controlled by a dual-axis LAC25.

Glass Grinding

Problem: The grinding process produces a 125µm finish with less than a 50µm variation. Damage to the glass at the beginning and end of the grinding cycle is caused by inadequate force control of the air cylinder which is driving the grind wheel. The force required is 2 to 4 Newtons, with a 5mm stroke.

Solution: Customer was able to land softly on the glass panel and provide a constant force using the "force mode" of the LAL55 at both beginning and end of the stroke.

Glass Scoring (V-Cutting)

- Scoring Organic Light Emitting Display (OLED) which measures only 0.5mm thick by using CAL36 series of electric actuator. Precise force control of less than 0.05N required. Soft-Land capability and low friction are key.

Glass Application Examples

- Glass cutting, de-burring, positioning
- Glass scoring (V-Cutting) for solar panels and LCDs
- Chamfering and bevelling
- Measuring surface profile

The SMAC 12 Month Product Guarantee

SMAC Corporation designs and manufactures advanced electric actuators. All SMAC actuators are quality products specifically designed and built for long service. Therefore, all actuators appearing in this catalog are guaranteed for a period of twelve months from the original date of shipment from our factory.

The guarantee conditions are effective when a SMAC Actuator is connected via a SMAC or SMAC Approved cable/connector and controlled by either a SMAC or SMAC Approved Controller. If a customer wishes to use a cable/connector or controller which is neither manufactured by, nor qualified/approved by SMAC, SMAC offers a test and qualification service to the customer. Once tested and approved the standard SMAC guarantee applies. Please contact your local SMAC branch for details. This guarantee is limited to a one-time replacement or rebuilding of any actuator which should fail to operate properly. Actuators must be returned with transportation prepaid and received at our factory within the guarantee period. They will be returned to the customer at the expense of SMAC.

No claims for labor, material, time, damage or transportation are allowable. Actuators damaged as a result of misapplication by the customer are excluded from this guarantee. The guarantee does not apply to loss or damage caused by fire, theft, riot, explosion, labor dispute, act of God or other causes beyond the control of SMAC. SMAC shall in no event be liable for remote, special or consequential damages, under the SMAC guarantee or under any implied warranty.

The above guarantee is our manner of extending the engineering and service resources of the SMAC organization to assure our customers long and continued satisfaction.

The SMAC Rebuild Program

Actuators no longer covered by the SMAC guarantee can be rebuilt under the SMAC rebuild program. Our continued research and development program extends the life of our actuators making them even more reliable under adverse operating conditions. Actuators returned under this program are completely disassembled, inspected and rebuilt to current operating standards wherever possible, tested and returned within a few days for a reasonable charge (typically 35% of standard list price). For 90 days from date of shipment from our factory, all rebuilt actuators carry the same guarantee as provided for new actuators.

SMAC products have been tested and found to be fully compliant with EN 50082-2 & EN 55011 Group 1, Class A.

Terms & Conditions of Sale

SMAC manufactures and sells actuators, controllers and cables. It has a standard warranty policy covering these products. SMAC does not offer integration services. These are the responsibility of SMAC distribution and their customers. This means SMAC takes no responsibility for software programming, mechanical designs and all other engineering involved in a project using SMAC devices. SMAC may, at its discretion, offer technical recommendations or suggestions to help its customer, the distributor, on a particular application. SMAC will only do this once a signed release of responsibility is received from its customer.

U.S. and world wide patents issued & applied for. SMAC improves its product line on a continuing basis. Specifications and mechanical dimensions are subject to change without notice. Please consult factory before proceeding with your design.



5807 Van Allen Way
Carlsbad, CA 92008
Tel: 760-929-7575
Fax: 760-929-7588
Email: info@smac-mca.com
www.smac-mca.com

National & International Offices

North America

SMAC Midwest (MI)

Suite 175
4595 Broadmoor Ave. S.E.
Grand Rapids, MI 49512
Tel: +1 616-554-5672
Fax: +1 616-554-5762
Email: smacmidwest@tds.net

SMAC Midwest (IL)

Tel: +1 312-446-8643
Email: haidos@gmail.com

SMAC Mexico

Tel: +52 462-155-17-69 (international)
045-462-155-17-69 (inside Mexico)
Email: hlecona-smac@prodigy.net.mx

SMAC South America

Francisco De Olea 5760 – CP: 5147 –
Córdoba, Argentina
Cell: +54 9 351 7 604 557
E-mail: jmreynoso@smac-mca.com.ar

Europe

SMAC Europe Ltd.

Ikon House, Rutherford Way
Crawley, West Sussex
United Kingdom RH10 9PB
Tel: +44 (0)1293-520147
Fax: +44 (0)1293-539829
Email: info@smac-mca.co.uk

SMAC The Netherlands

Steenovenweg 5
5708 HN Helmond
Postbus 172, 5700 AD Helmond
Tel: +31 (0)492-472494
Fax: +31 (0)492-472600
Email: info@smac-mca.nl

SMAC Germany

Turnstr. 22c
75228 Ispringen
Tel: +49 (0)7231 8008-760
Fax: +49 (0)7231 8008-744
Email: info@smac-mca.de

SMAC Switzerland

En Chamard 55b
CH-1442 Montagny-près-Yverdon
Tel: +41 (0)79-629-17-49
Fax: +41(0)86-079-629-17-49
Email: martin.frei@smac-mca.ch

Asia

SMAC Japan

West World Bldg. 7F
3-1-6 Higashi Gotanda
Shinagawa-ku, Tokyo
Japan 141-0022
Tel: 81-(0)3-6408-5358
Fax: 81-(0)3-6408-5359
Email: smacjapan@smac-mca.co.jp

SMAC Taiwan

1F, 110-1, Cheng Gong Road, San
Chong City, Taipei County, Taiwan
Tel: +886-2-2974-9732
Fax: +886-2-2974-3706
Email: sales@smac-mca.com.tw

SMAC Korea

427-18, 1F, ShinGok-Dong,
UiJeongBu-Si, Gyeonggi-Do, Rep.
of Korea (480-838)
Tel: +82-70-8784-9006
Fax: +82-31-851-6015
Cell: +82-10-3934-9006
Email: smac.korea@yahoo.com

SMAC China (Shanghai)

Shanghai ZIZHU Science-based
Industrial Park
5004,5005 Room, 5th Floor, 2 Bldg.
555 Dongchuan Road
Shanghai 200240
Tel: +86 (0)21-6435-1661
Fax: +86 (0)21-3429-0092
Cell: +86 (0)133-1186-5359
Email: smac.sh@163.com

SMAC Malaysia

Tel: +6012 7036618
Email: tapakhkeong99@yahoo.com