

**ROBO Cylinder with Battery-less
Absolute Encoder as Standard Equipment**

RCP5

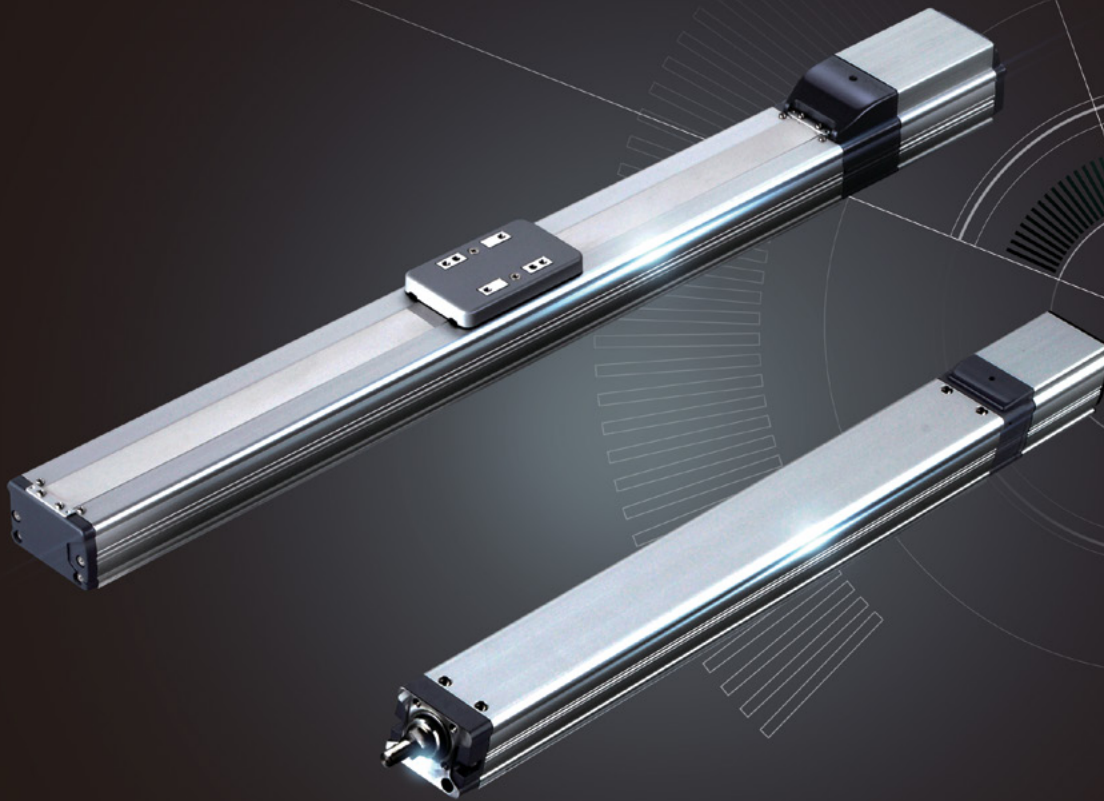

Battery-Less
ABSOLUTE

Introducing the RCP5 series actuator with battery-less absolute encoder, realizing the convenience of an absolute encoder along with the cost and simplicity of an incremental encoder

The battery-less absolute encoder is an innovative encoder requiring no hassle or cost of battery replacement or adjustment associated therewith (patent pending), as rotational position data is recognized by a combination of gears to make the battery, which has been a required component of any traditional absolute encoder, no longer necessary. This encoder is ideal for the automobile industry and other production facilities where many absolute type actuators are used.

Slider type

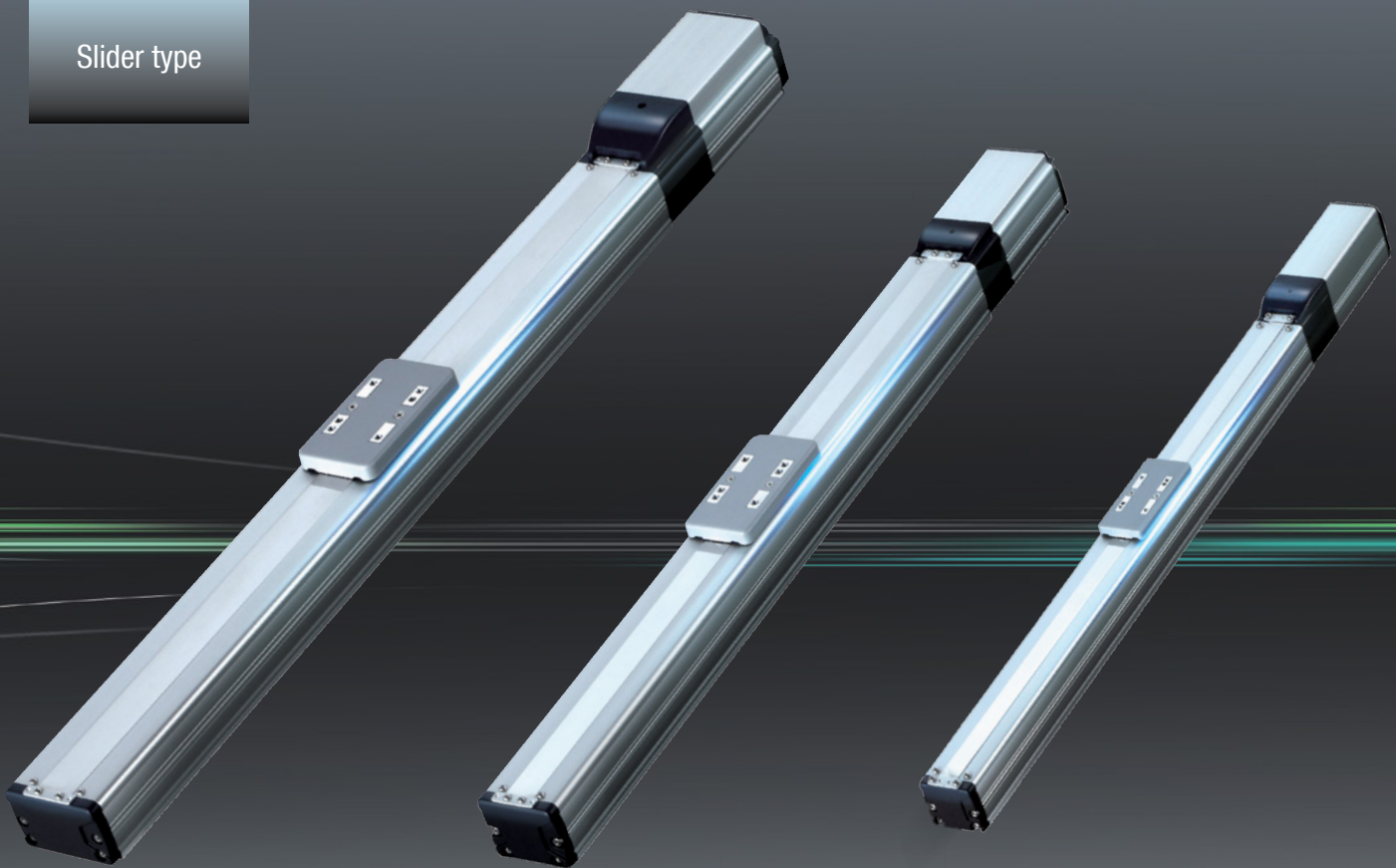

RCP5-SA7C

RCP5-SA6C

RCP5-SA4C

The Industry's First

Electric Actuator with Built-in Battery-less Absolute Encoder

RCP5-SA4C (with Battery-less Absolute Encoder)

Standard price —

Controller and cables are sold separately.

Rod type



RCP5-RA7C

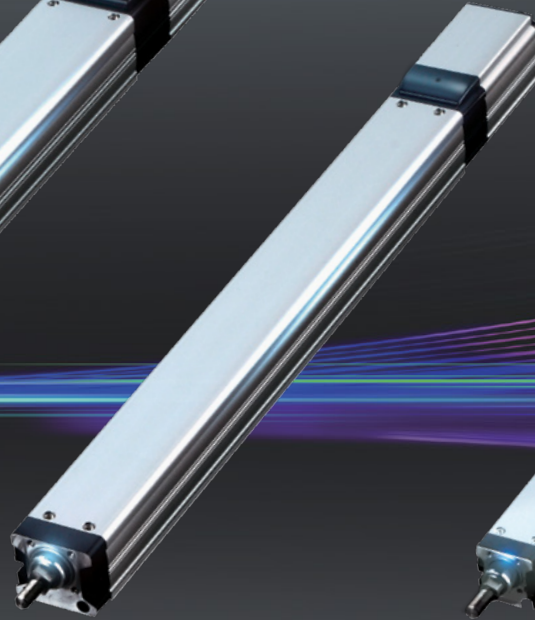

RCP5-RA6C

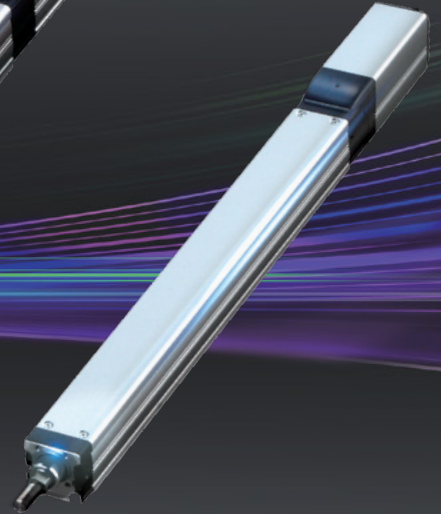

RCP5-RA4C

Controller

Single-axis Controller

PCON-CA

Supporting the battery-less absolute encoder

1-axis position control

Supporting the Power CON

Supporting field networks



6-axis controller with PLC function

MSEP-LC

Supporting the battery-less absolute encoder

PLC function

6-axis position control

Supporting the Power CON (3 axes)

Supporting field networks



8-axis controller

MSEP-C

Supporting the battery-less absolute encoder

8-axis position control

Supporting the Power CON (4 axes)

Supporting field networks

The ROBO Cylinder is Easy to Use!!!

No More Problems

Shop-Floor Problems and Solutions

Air cylinder problems

- 1 Reduced operation rate due to choco-tei caused by the auto switch failure or air pressure fluctuations
- 2 Difficult to shorten cycle-time due to the speed limit from the shock caused by a stoppage

Electric actuator problem (Incremental type)

A long time is required to return to home or for an adjustment after an emergency stop is reset

Electric actuator problem (Absolute type)

- 1 Higher cost
- 2 Battery replacement time management is required
- 3 Battery replacement labor and cost



Solved with an electric actuator (CT Effects)*

- 1 Choco-tei significantly reduced
- 2 Speed increase now possible with no shock caused by a stoppage

Solved with the absolute type

Home return not required

Solved with the battery-less absolute type

- 1 Battery is not required
- 2 Slider type offered at the same price as the incremental type

Problems solved with the RCP5 Series!

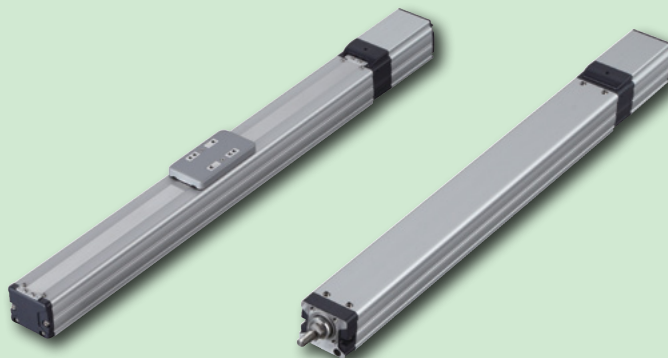

Battery-Less
ABSOLUTE

* The "CT Effects" refer to increased production output per unit time with "shorter cycle time" and "reduced choco-tei" achieved by re-examining the devices that are part of automation equipment.

Battery-less absolute

What is an absolute encoder?

Incremental type

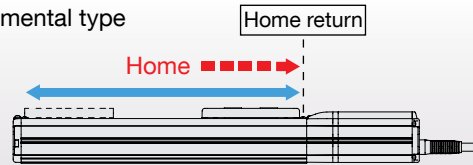

The home reference is lost when the power is shut down. This type of encoder will return to home before making a commanded move after a power cycle.

Absolute type

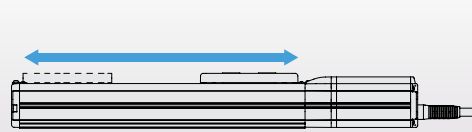

With this type, position data is retained even if the power is shut down and it can be started from the current position where the power is turned on.

Advantages of an absolute encoder

Advantage 1:

Home return is not required, which means reduced amount of labor and time required for adjustment when starting up the device.

Advantage 2:

The amount of time required is reduced for adjustment to restart the device after an emergency stop.

What is a battery-less absolute encoder?

A battery-less absolute encoder is an absolute encoder that verifies the current position based on the interlocked gear position. On conventional absolute encoders, the current position was stored by using a battery. The battery-less type is now available and a battery to store data is no longer required.



Advantages of a battery-less absolute encoder

Advantage 1:

More economical with no cost associated with battery replacement.

Advantage 2:

Battery replacement management is no longer required. Labor for replacement work is also no longer required.

Advantage 3:

Battery installation space is not required.

Advantage 4:

Operation can resume with no adjustment required even when the cable between the controller and the actuator is replaced because the positional information is read each time.

Advantage 5:

No external sensor, such as a sensor to check the origin, is required since home return is not necessary.

Advantage 6:

IAI's slider type, even with the battery-less absolute encoder, is offered for the same price as the conventional incremental type.

Service life of a battery-less absolute encoder

The mechanical configuration of the battery-less absolute encoder offers a service life that is approximately four times the actuator guide's standard rating. Furthermore, it can be used with a sense of security because it will output an error when a certain amount of wear in the gear section is detected.

The ROBO Cylinder is Easy to Use!!!

Feature **2**

1.5 times higher maximum speed and double the payload when combined with a **Power CON**

Shorter Takt Time Significantly Boosts the Productivity of Your System

When the new controller <Power CON> is equipped with our newly developed high-output driver (patent pending) is used, the maximum speed increases significantly by up to 1.5 times the levels achievable with IA's conventional models, while the payload is greater by up to twice (*). In addition to these amazing improvements in specifications, the maximum speed does not drop as much even when the payload increases due to increased torque with the high speed motor, meaning that the dynamic performance equivalent to that of a higher-class model can be achieved at lower cost.

(*) The specific rates of improvement vary depending on the model.

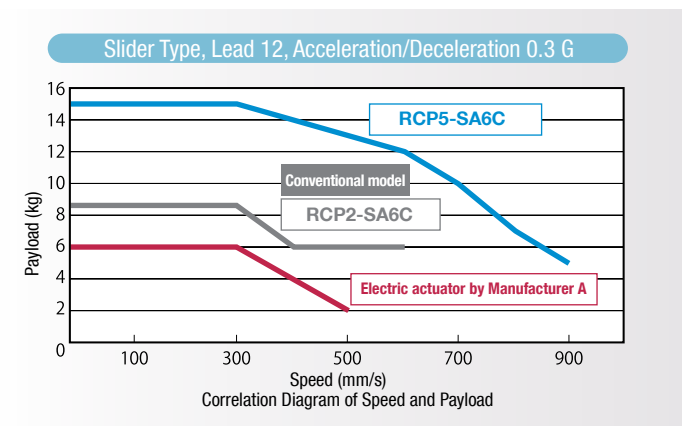

Multi-axis type is now available with a Power CON

The MSEP controller, now with a Power CON, is capable of operating the RCP5 in up to four-axis applications at high speeds 1.5 times the level achievable with the conventional models, and at a least double the dynamic payload performance. Additionally, the standard type not combined with a Power CON can operate the RCP5 in up to eight-axis applications. Furthermore, it can move to a specified value via a field network.

RCP5 operated in up to four-axis application*

Field network compatible



*Eight-axis application if a Power CON (high-output capable) is NOT used.

Feature **3**

The rod type can carry **radial loads**.

The rod type <Radial Cylinder> with a built-in guide mechanism can carry radial loads over a long stroke of up to 800mm.

The rod type <Radial Cylinder> has a built-in ball circulating type linear guide mechanism in the actuator to carry radial loads applied to the rod over a long stroke of up to 800mm. The actuator can also support a radial load applied at a position offset from the center of the rod.

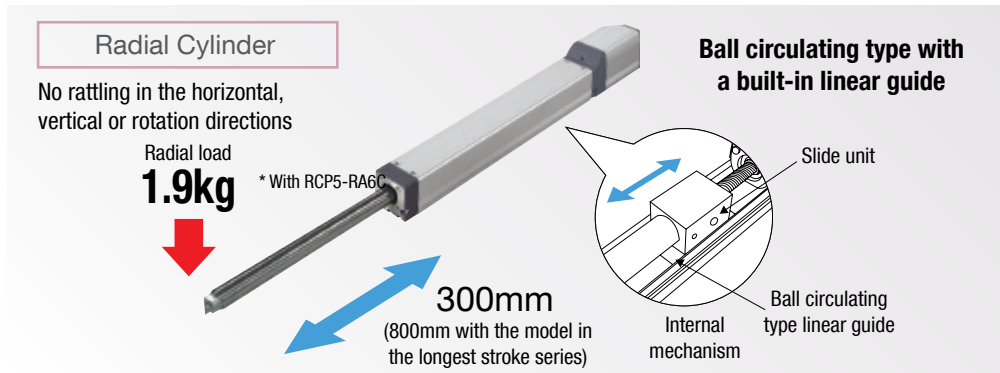

Usage example 1 When a guide mechanism is required in a tight space

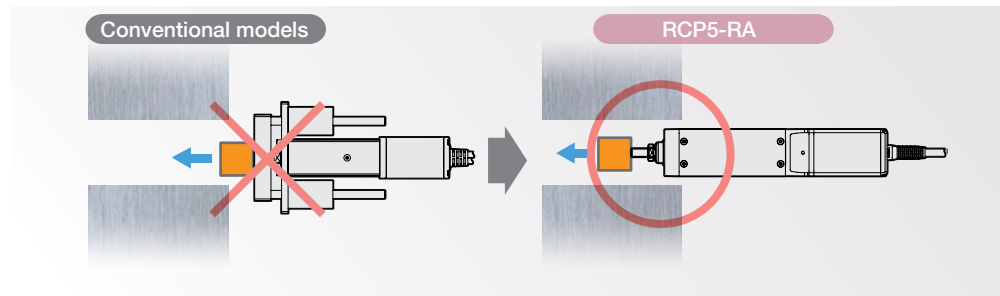

Usage example 2 When the rod needs to be straight

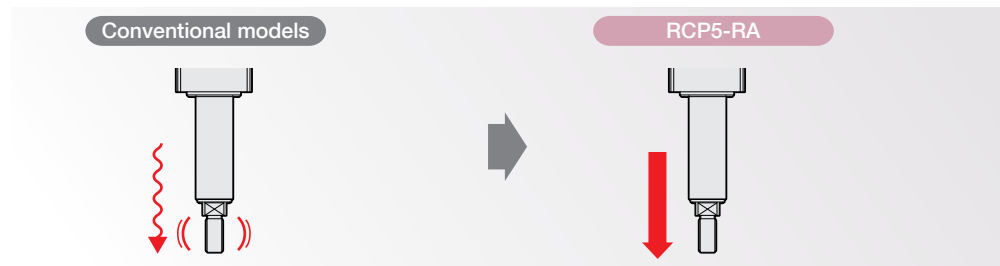

Feature **4**

Easier to Maintain

Greasing has become easier, as the ball screw and guide can be lubricated at the same time from the two grease nipples on the left and right, accessible when the frame cover is removed.

* This feature is not available for RCP5-RA8/RA10.

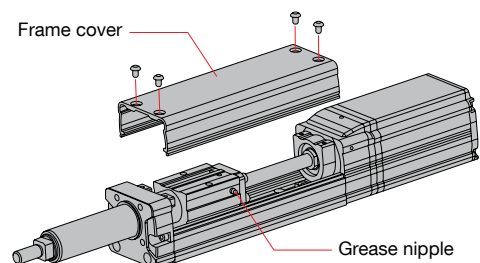

The ROBO Cylinder is Easy to Use!!!

Model type



Slider type

→ P.11

Type	External view	Actuator width	Stroke (mm)	Ball screw lead (mm)	Maximum speed (mm/s)	Maximum payload (kg)		Page
						Horizontal	Vertical	
SA4C		 40mm	50~500	16	1260	4	1	→P.11
				10	785	10	2.25	
				5	390	12	4.5	
				2.5	195	12	9	
SA6C		 58mm	50~800	20	1440 <1280>	10	1	→P.13
				12	900	15	2.5	
				6	450	25	6	
				3	225	25	16	
SA7C		 73mm	50~800	24	1200	20	3	→P.15
				16	980 <840>	40	8	
				8	490	45	16	
				4	245 <210>	45	25	

Rod type

→ P.17

Type	External view	Actuator width	Stroke (mm)	Ball screw lead (mm)	Maximum speed (mm/s)	Maximum payload (kg)		Page
						Horizontal	Vertical	
RA4C		 40mm	60~410	16	1120 <840>	6	1.5	→P.17
				10	700	15	2.5	
				5	350	28	5	
				2.5	175	40	10	
RA6C		 58mm	65~415	20	800	6	1.5	→P.19
				12	700	25	4	
				6	450	40	10	
				3	225	60	20	
RA7C		 73mm	70~520	24	800 <600>	20	3	→P.21
				16	700 <560>	50	8	
				8	420	60	18	
				4	210	80	28	



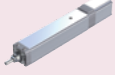
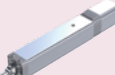
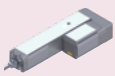
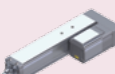

Rod type

→ P.23

Model	Type	External view	Actuator width	Stroke (mm)	Ball screw lead (mm)	Maximum speed (mm/s)	Maximum payload (kg)		Page
							Horizontal	Vertical	
Straight motor specification	RA8C		88mm	50~700	20	600 <450>	30	5	→P.23
					10	300 <250>	60	40	
					5	150	100	70	
	RA10C		108mm	50~800	10	250 <167>	80	80	→P.25
					5	125	150	100	
					2.5	63	300	150	
Side-mounted motor specification	RA8R		88mm	50~700	20	400	30	5	→P.27
					10	200	60	40	
					5	100	100	70	
	RA10R		108mm	50~800	10	200 <140>	80	80	→P.29
					5	100	150	100	
					2.5	50	300	150	

Controller

→ P.39

Maximum number of connected axes	Type	External view	PLC function	Applicable encoder	Power-supply voltage	Features	Page
1 axis	PCON-CA/CFA		—	Incremental Simple absolute Battery-less absolute	DC24V	Single-axis positioner is designed for easy control using PIOs. Common boards are used to let you operate the range of actuators from RCP2 through RCP5 with the same controller by simply changing the parameters.	→P.39
8 axes	MSEP-C		—			8-axis positioner is designed for easy control using PIOs. A combination of pulse motor, AC servo motor and DC servo motor actuators can be operated with one controller.	→P.47
6 axes	MSEP-LC		○			The I/O control function supports standalone operation and control of peripheral equipment.	

The ROBO Cylinder is Easy to Use!!!

Model Specification Items

Model Specification Items

<Slider type>

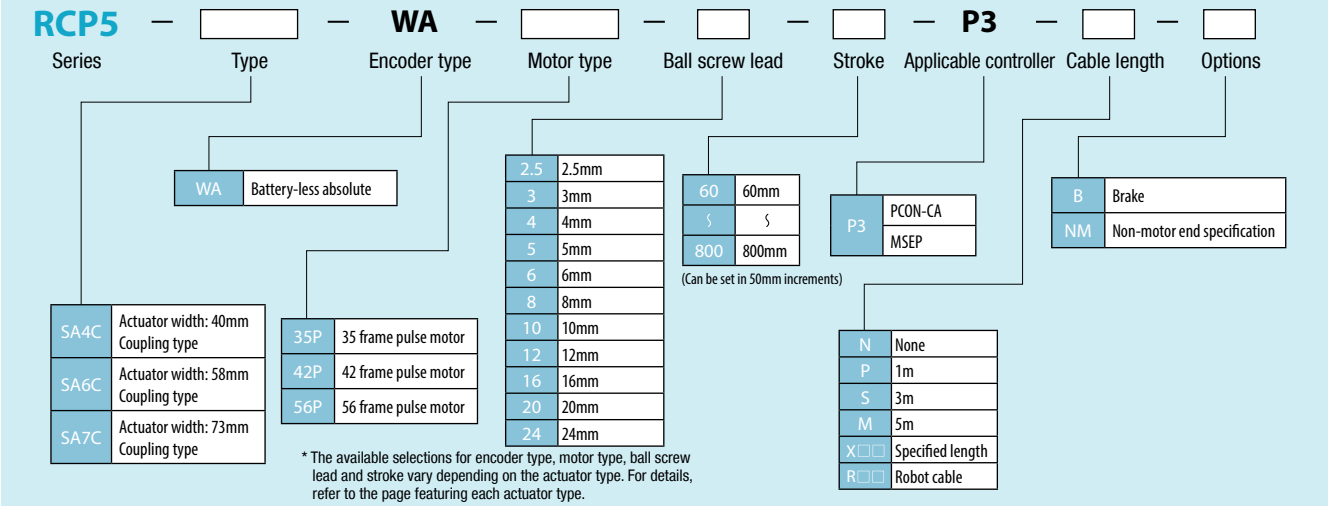

<Rod type RA4/RA6/RA7>

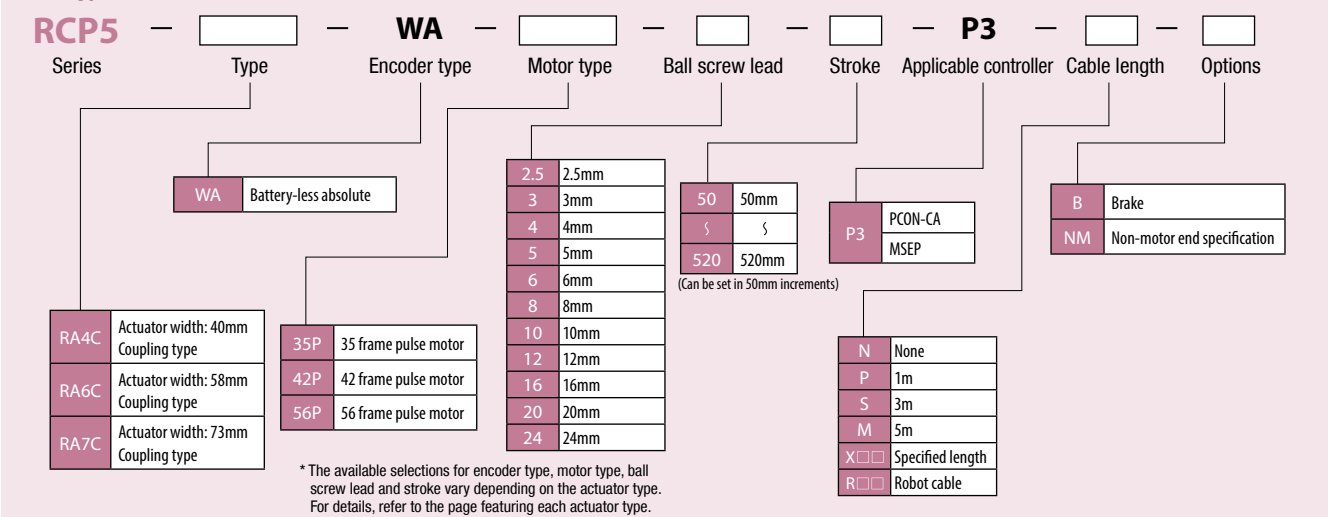

<Rod type RA8/RA10>

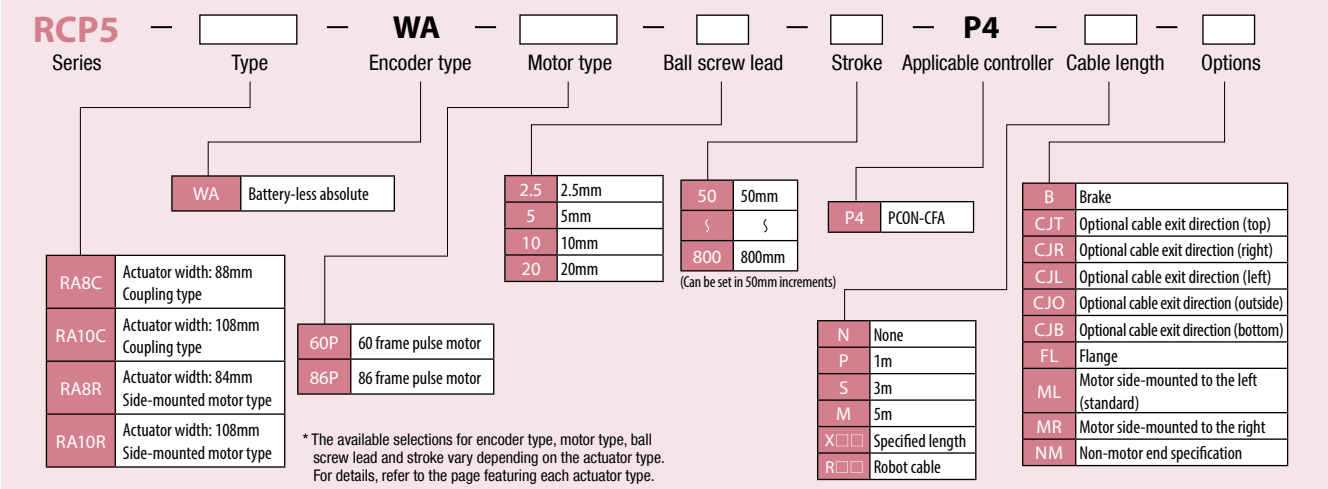

Actuator Options

Brake
Option code: **B**

Applicable models **All models**

Description A mechanism that is used to hold the slider or rod in place when the actuator is used vertically, so that it will not drop and damage the work part, etc., when the power or servo is turned off.

Optional cable exit direction
Option code:
CJT
CJR
CJL
CJB
CJO

Applicable models **RCP5-RA8C/RA10C/RA8R/RA10R**

Description Select this option if you want to change the exit direction of the motor/encoder cables to the top, bottom, left or right.

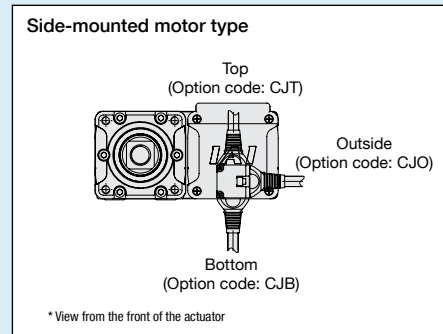
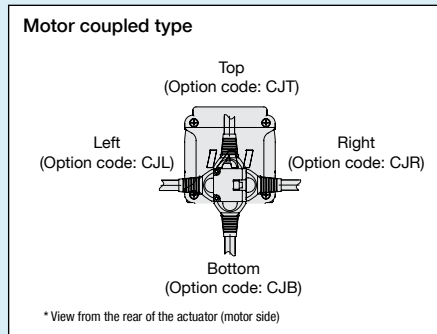

Side-mounted motor direction
Option code:
ML/MR

* Be sure to specify either "ML" or "MR" for the side-mounted motor type.

Applicable models **RCP5-RA8R/RA10R**

Description The side-mounted motor direction can be specified. ML and MR represent the left and right, respectively, as viewed from the motor side of the actuator.

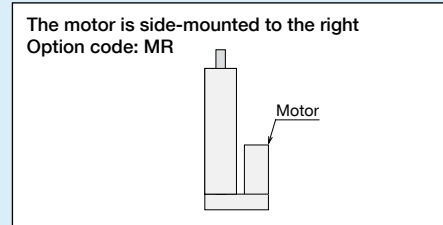
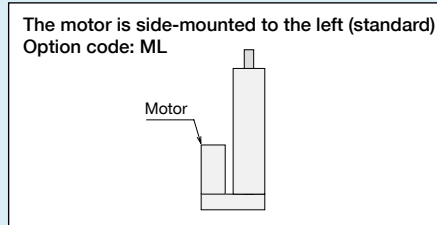

Non-motor end specification
Option code: **NM**

Applicable models **All models**

Description Select this option if you want to change the home position of the actuator's slider or rod from the normal position (the motor end) to the front end.

Flange
Option code: **FL**

Applicable models **RCP5-RA8C/RA8R/RA10C/RA10R**

Description A bracket that is used to secure a rod actuator from the actuator side. The flange can be purchased separately later on.

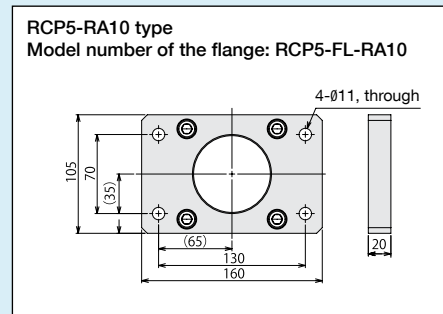
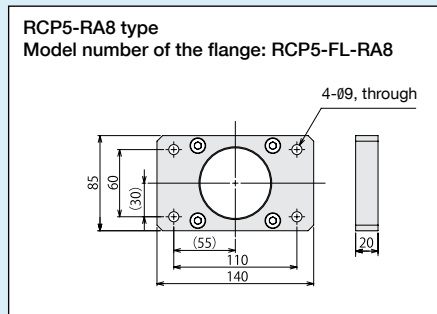

RCP5-SA4C

ROBO Cylinder, Slider Type, Motor Unit Coupled, Actuator Width 40mm, 24-V Pulse Motor

Model Specification Items	RCP5 — SA4C — WA — 35P — <input type="checkbox"/> — <input type="checkbox"/> — P3 — <input type="checkbox"/> — <input type="checkbox"/>
	Series — Type — Encoder type — Motor type — Lead — Stroke — Applicable controller — Cable length — Options
	WA : Battery-less absolute specification 35P : Pulse motor, size 35 <input type="checkbox"/> 16 : 16mm 10 : 10mm 5 : 5mm 2.5 : 2.5mm 50 : 50mm 500 : 500mm (every 50mm) P3 : PCON-CA MSEP-C/LC N : None P : 1m S : 3m M : 5m X <input type="checkbox"/> : Specified length R <input type="checkbox"/> : Robot cable



Correlation Diagrams of Speed and Payload

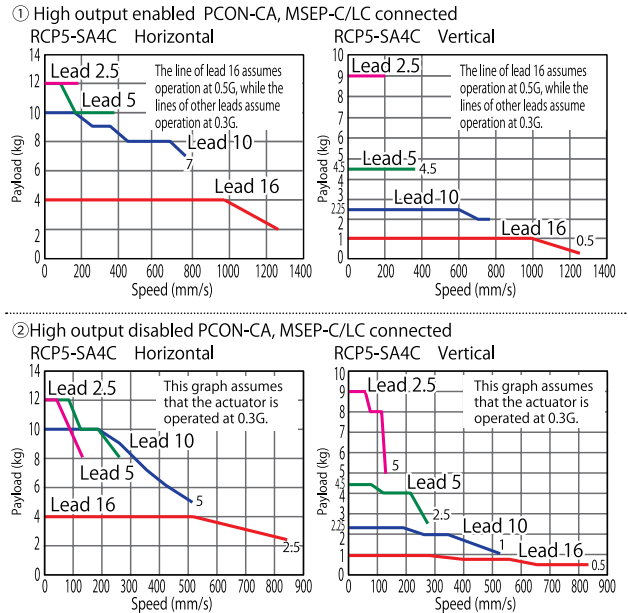

POINT
Note on selection

(1) The payload in "Actuator Specifications" represents the maximum values, but the payload of a specific model varies depending on the acceleration. For details, refer to "Selection Guideline" (Table of RCP5 Payload by Speed/Acceleration) on pp. 33 to 34.

(2) Refer to P. 31 for the push-motion operation.

Actuator Specifications

Lead and Payload

Model number	Lead (mm)	Connected controller	Maximum payload		Stroke (mm)
			Horizontal (kg)	Vertical (kg)	
RCP5-SA4C-WA-35P-16-①-P3-②-③	16	High output enabled PCON-CA MSEP-C/LC High output disabled PCON-CA MSEP-C/LC	4	1	50~500 (every 50mm)
RCP5-SA4C-WA-35P-10-①-P3-②-③	10	High output enabled PCON-CA MSEP-C/LC High output disabled PCON-CA MSEP-C/LC	10	2.25	
RCP5-SA4C-WA-35P-5-①-P3-②-③	5	High output enabled PCON-CA MSEP-C/LC High output disabled PCON-CA MSEP-C/LC	12	4.5	
RCP5-SA4C-WA-35P-2.5-①-P3-②-③	2.5	High output enabled PCON-CA MSEP-C/LC High output disabled PCON-CA MSEP-C/LC	12	9	

Code explanation ① Stroke ② Cable length ③ Options

Stroke and Maximum Speed

(unit: mm/s)

Lead (mm)	Connected controller	50~400 (every 50mm)			450 (mm)	500 (mm)
		50~400 (every 50mm)	450 (mm)	500 (mm)		
16	High output enabled PCON-CA MSEP-C/LC	1260	1060	875		
	High output disabled PCON-CA MSEP-C/LC		840			
10	High output enabled PCON-CA MSEP-C/LC	785	675	555		
	High output disabled PCON-CA MSEP-C/LC		525			
5	High output enabled PCON-CA MSEP-C/LC	390	330	275		
	High output disabled PCON-CA MSEP-C/LC		260			
2.5	High output enabled PCON-CA MSEP-C/LC	195	165	135		
	High output disabled PCON-CA MSEP-C/LC		130			

① Stroke

Stroke (mm)	Standard price	Stroke (mm)	Standard price
50	—	300	—
100	—	350	—
150	—	400	—
200	—	450	—
250	—	500	—

② Cable Length

Type	Cable symbol	Standard price
Standard type	P (1m)	—
	S (3m)	—
	M (5m)	—
Special length	X06 (6m) ~ X10 (10m)	—
	X11 (11m) ~ X15 (15m)	—
	X16 (16m) ~ X20 (20m)	—
	R01 (1m) ~ R03 (3m)	—
Robot cable	R04 (4m) ~ R05 (5m)	—
	R06 (6m) ~ R10 (10m)	—
	R11 (11m) ~ R15 (15m)	—
	R16 (16m) ~ R20 (20m)	—

③ Option

Name	Option code	See page	Standard price
Brake	B		—
Non-motor end specification	NM	→P.10	—

Actuator Specifications

Item	Description
Drive system	Ball screw ø8mm, rolled C10
Positioning repeatability	±0.02mm
Lost motion	0.1 mm or less
Base	Material: Aluminum with white alumite treatment
Guide	Linear guide
Dynamic allowable moment (*1)	Ma: 3.9 N·m, Mb: 5.5 N·m, Mc: 7.5 N·m
Allowable overhang	120mm or less in Ma, Mb and Mc directions
Ambient operating temperature, humidity	0 to 40°C, 85% RH or less (Non-condensing)

(*1) Based on 5,000km of traveling life

Allowable load moment directions

Overhang load lengths

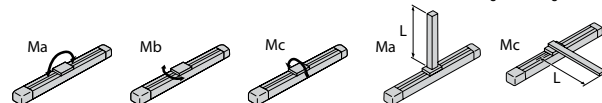

Dimensional Drawings

CAD drawings can be downloaded from the website: www.intelligentactuator.com



*1 During home return, be careful to avoid interference from peripheral objects because the slider travels until the mechanical end.
ME: Mechanical end
SE: Stroke end

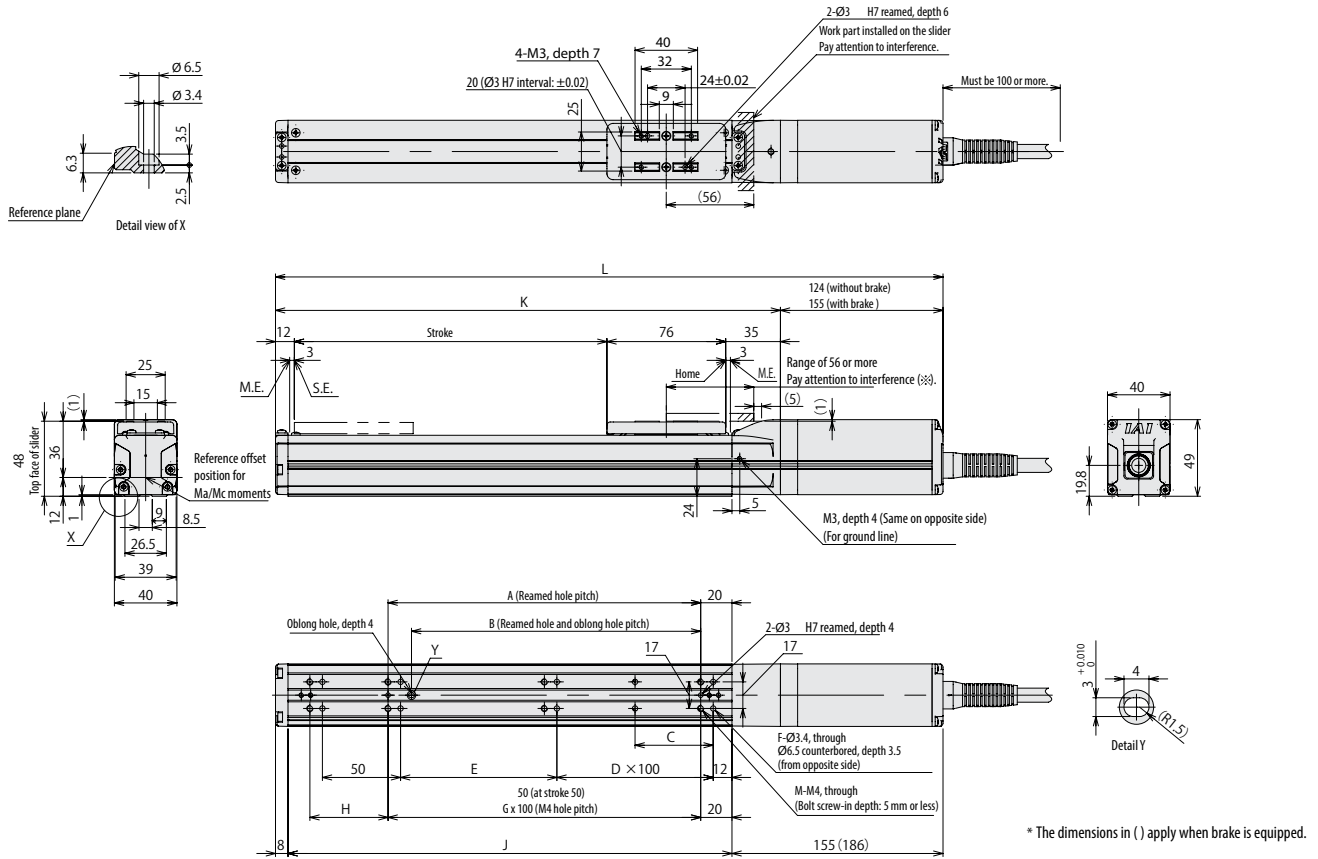

* The dimensions in () apply when brake is equipped.

Dimensions and Mass by Stroke

Stroke	50	100	150	200	250	300	350	400	450	500
	L	297	347	397	447	497	547	597	647	697
Without brake	297	347	397	447	497	547	597	647	697	747
With brake	328	378	428	478	528	578	628	678	728	778
A	50	100	100	200	200	300	300	400	400	500
B	35	85	85	185	185	285	285	385	385	485
C	25	50	50	50	50	50	50	50	50	50
D	0	0	1	1	2	2	3	3	4	4
E	50	100	50	100	50	100	50	100	50	100
F	8	8	10	10	12	12	14	14	16	16
G	-	1	1	2	2	3	3	4	4	5
H	50	50	100	50	100	50	100	50	100	50
J	134	184	234	284	334	384	434	484	534	584
K	173	223	273	323	373	423	473	523	573	623
M	6	6	6	8	8	10	10	12	12	14
Mass (kg)	1.0	1.1	1.2	1.3	1.3	1.4	1.5	1.6	1.7	1.8
Without brake	1.0	1.1	1.2	1.3	1.3	1.4	1.5	1.6	1.7	1.8
With brake	1.2	1.3	1.4	1.5	1.5	1.6	1.7	1.8	1.9	2.0

Applicable Controller

RCP5 series actuators can be operated with the controller indicated below. Select the type according to your intended application.

Name	External view	Model number	Features	Maximum number of positioning points	Input power	Power supply capacity	Standard price	Reference page
Positioner type		PCON-CA-35PWAI-NP-□-0-□ PCON-CA-35PWAI-PN-□-0-□	Equipped with a high-output driver Positioner type based on PIO control	512 points	DC24V	Refer to P. 46	—	Refer to P. 39
Pulse-train type		PCON-CA-35PWAI-PLN-□-0-□ PCON-CA-35PWAI-PLP-□-0-□	Equipped with a high-output driver Pulse-train input type	—			—	
Field network type		PCON-CA-35PWAI-□-0-0-□	Equipped with a high-output driver Supporting major field networks	768 points			—	
Position controller, 8-axis type	MSEP-C-□-35PWAI-□-□-0	Positioner type that accepts connection of up to eight axes.	3 points/256 points	Refer to P. 55			Contact IAL	Refer to P. 47
6-axis type with I/O control function	MSEP-LC-□-35PWAI-□-□-0-□	Axes can be moved and I/O signal turned ON/OFF using a ladder logic program.	256 points					

* In the model numbers shown above, ① indicates the field network specification (DV, CC, PR, CN, ML, EC or EP)

RCP5-SA6C

ROBO Cylinder, Slider Type, Motor Unit Coupled, Actuator Width 58mm, 24-V Pulse Motor

Model Specification Items	RCP5 — SA6C — WA — 42P — <input type="checkbox"/> — <input type="checkbox"/> — P3 — <input type="checkbox"/> — <input type="checkbox"/>
	Series — Type — Encoder type — Motor type — Lead — Stroke — Applicable controller — Cable length — Options
	WA : Battery-less absolute specification 42P : Pulse motor, size 42 <input type="checkbox"/> 20 : 20mm 12 : 12mm 6 : 6mm 3 : 3mm 50 : 50mm 800 : 800mm (every 50mm) P3 : PCON-CA MSEP-C/LC N : None P : 1m S : 3m M : 5m X <input type="checkbox"/> : Specified length R <input type="checkbox"/> : Robot cable Refer to the options table below.

RoHS



Correlation Diagrams of Speed and Payload

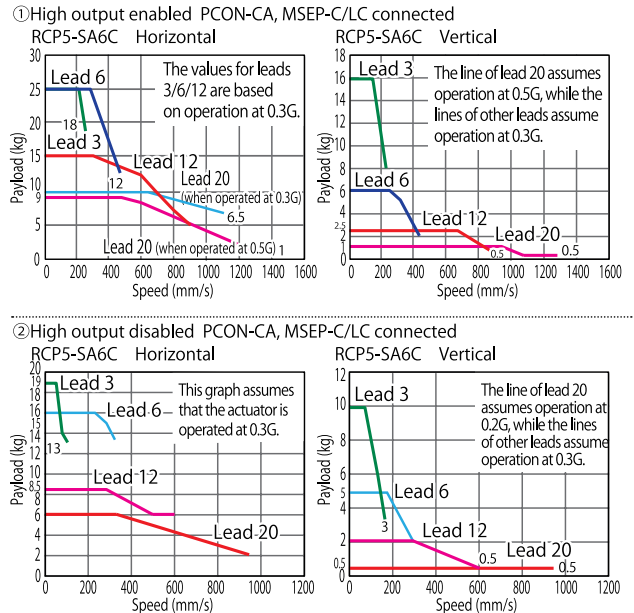

POINT
Note on selection

(1) The payload in "Actuator Specifications" represents the maximum values, but the payload of a specific model varies depending on the acceleration. For details, refer to "Selection Guideline" (Table of RCP5 Payload by Speed/Acceleration) on pp. 33 to 34.

(2) Refer to P. 31 for the push-motion operation.

Actuator Specifications

Lead and Payload

Model number	Lead (mm)	Connected controller	Maximum payload		Stroke (mm)
			Horizontal (kg)	Vertical (kg)	
RCP5-SA6C-WA-42P-20-①-P3-②-③	20	High output enabled PCON-CA MSEP-C/LC	10	1	50~800 (every 50mm)
		High output disabled PCON-CA MSEP-C/LC	6	0.5	
RCP5-SA6C-WA-42P-12-①-P3-②-③	12	High output enabled PCON-CA MSEP-C/LC	15	2.5	
		High output disabled PCON-CA MSEP-C/LC	8.5	2	
RCP5-SA6C-WA-42P-6-①-P3-②-③	6	High output enabled PCON-CA MSEP-C/LC	25	6	
		High output disabled PCON-CA MSEP-C/LC	16	5	
RCP5-SA6C-WA-42P-3-①-P3-②-③	3	High output enabled PCON-CA MSEP-C/LC	25	16	
		High output disabled PCON-CA MSEP-C/LC	19	10	

Code explanation ① Stroke ② Cable length ③ Options

Stroke and Maximum Speed

The values in < > apply when the actuator is used vertically. (unit: mm/s)

Lead (mm)	Connected controller	Maximum speed (mm/s)								
		50~400 (every 50mm)	450 (mm)	500 (mm)	550 (mm)	600 (mm)	650 (mm)	700 (mm)	750 (mm)	800 (mm)
20	High output enabled PCON-CA MSEP-C/LC	1440 (1280)		1335 (1280)	1130	970	840	735	650	575
	High output disabled PCON-CA MSEP-C/LC	960				840	735	650	575	
12	High output enabled PCON-CA MSEP-C/LC	900	885	735	620	535	460	405	355	315
	High output disabled PCON-CA MSEP-C/LC	600				535	460	405	355	315
6	High output enabled PCON-CA MSEP-C/LC	450	435	365	305	265	230	200	175	155
	High output disabled PCON-CA MSEP-C/LC	300				265	230	200	175	155
3	High output enabled PCON-CA MSEP-C/LC	225	215	180	150	130	115	100	85	75
	High output disabled PCON-CA MSEP-C/LC	150				130	115	100	85	75

① Stroke

Stroke (mm)	Standard price	Stroke (mm)	Standard price
50	—	450	—
100	—	500	—
150	—	550	—
200	—	600	—
250	—	650	—
300	—	700	—
350	—	750	—
400	—	800	—

② Cable Length

Type	Cable symbol	Standard price
Standard type	P(1m)	—
	S(3m)	—
	M(5m)	—
Special length	X06(6m) ~ X10(10m)	—
	X11(11m) ~ X15(15m)	—
	X16(16m) ~ X20(20m)	—
Robot cable	R01(1m) ~ R03(3m)	—
	R04(4m) ~ R05(5m)	—
	R06(6m) ~ R10(10m)	—
	R11(11m) ~ R15(15m)	—
	R16(16m) ~ R20(20m)	—

③ Option

Name	Option code	See page	Standard price
Brake	B		—
Non-motor end specification	NM	→P.10	—

Actuator Specifications

Item	Description
Drive system	Ball screw ø10mm, rolled C10
Positioning repeatability (*1)	±0.02mm [±0.03]
Lost motion	0.1mm or less
Base	Material: Aluminum with white alumite treatment
Guide	Linear guide
Dynamic allowable moment (*2)	Ma: 8.9 N·m, Mb: 12.7 N·m, Mc: 18.6 N·m
Allowable overhang	150mm or less in Ma, Mb and Mc directions
Ambient operating temperature, humidity	0 to 40°C, 85% RH or less (Non-condensing)

(*1) The value at lead 20 is shown in [].

(*2) Based on 5,000km of traveling life.

Allowable load moment directions

Overhang load lengths

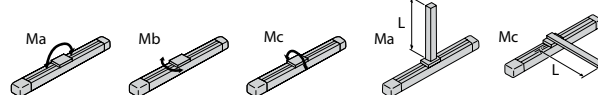

RCP5-SA7C

ROBO Cylinder, Slider Type, Motor Unit Coupled, Actuator Width 73mm, 24-V Pulse Motor

Model Specification Items	RCP5	SA7C	WA	56P	<input type="checkbox"/>	<input type="checkbox"/>	P3	<input type="checkbox"/>	<input type="checkbox"/>
	Series	Type	Encoder type	Motor type	Lead	Stroke	Applicable controller	Cable length	Options
			WA : Battery-less absolute specification	56P : Pulse motor, size 56 <input type="checkbox"/>	24 : 24mm 16 : 16mm 8 : 8mm 4 : 4mm	50 : 50mm 800 : 800mm (every 50mm)	P3 : PCON-CA MSEP-C/LC	N : None P : 1m S : 3m M : 5m X <input type="checkbox"/> : Specified length R <input type="checkbox"/> : Robot cable	Refer to the options table below.



- The payload in "Actuator Specifications" represents the maximum values, but the payload of a specific model varies depending on the acceleration. For details, refer to "Selection Guideline" (Table of RCP5 Payload by Speed/Acceleration) on pp. 33 to 34.
- Refer to P. 31 for the push-motion operation.

Correlation Diagrams of Speed and Payload

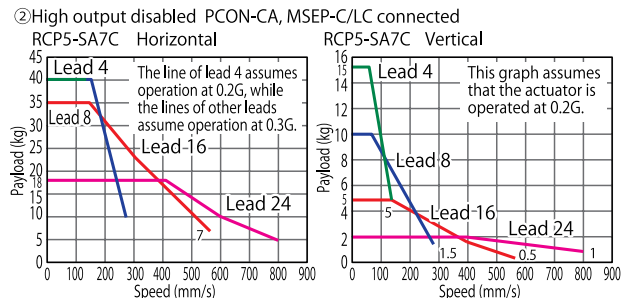
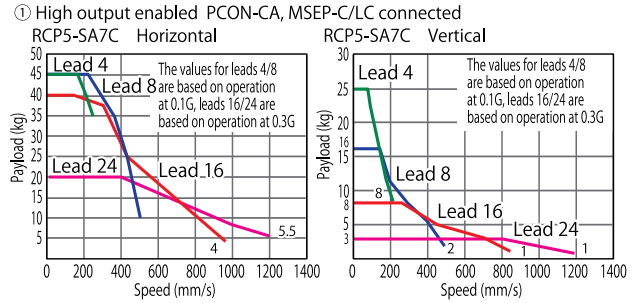

Actuator Specifications

Lead and Payload

Model number	Lead (mm)	Connected controller	Maximum payload		Stroke (mm)
			Horizontal (kg)	Vertical (kg)	
RCP5-SA7C-WA-56P-24-①-P3-②-③	24	High output enabled PCON-CA MSEP-C/LC	20	3	50~800 (every 50mm)
		High output disabled PCON-CA MSEP-C/LC	18	2	
RCP5-SA7C-WA-56P-16-①-P3-②-③	16	High output enabled PCON-CA MSEP-C/LC	40	8	
		High output disabled PCON-CA MSEP-C/LC	35	5	
RCP5-SA7C-WA-56P-8-①-P3-②-③	8	High output enabled PCON-CA MSEP-C/LC	45	16	
		High output disabled PCON-CA MSEP-C/LC	40	10	
RCP5-SA7C-WA-56P-4-①-P3-②-③	4	High output enabled PCON-CA MSEP-C/LC	45	25	
		High output disabled PCON-CA MSEP-C/LC	40	15	

Code explanation ① Stroke ② Cable length ③ Options

Stroke and Maximum Speed

The values in <> apply when the actuator is used vertically. (unit: mm/s)

Lead (mm)	Connected controller	50-400 (every 50mm)	600 (mm)	650 (mm)	700 (mm)	750 (mm)	800 (mm)
		24	High output enabled PCON-CA MSEP-C/LC	1200	1145	1000	885
16	High output disabled PCON-CA MSEP-C/LC	800					785
	High output enabled PCON-CA MSEP-C/LC	980 <840>	875 <840>	755	660	585	520
8	High output disabled PCON-CA MSEP-C/LC	560					520
	High output enabled PCON-CA MSEP-C/LC	490	430	375	325	290	255
4	High output disabled PCON-CA MSEP-C/LC	280					255
	High output enabled PCON-CA MSEP-C/LC	245 <210>	215 <210>	185	160	140	125
4	High output disabled PCON-CA MSEP-C/LC	140					125

① Stroke

Stroke (mm)	Standard price	Stroke (mm)	Standard price
50	—	450	—
100	—	500	—
150	—	550	—
200	—	600	—
250	—	650	—
300	—	700	—
350	—	750	—
400	—	800	—

② Cable Length

Type	Cable symbol	Standard price	Type	Cable symbol	Standard price
Standard type	P (1m)	—	Robot cable	R01(1m) ~ R03(3m)	—
	S (3m)	—		R04(4m) ~ R05(5m)	—
	M (5m)	—		R06(6m) ~ R10(10m)	—
Special length	X06(6m) ~ X10(10m)	—		R11(11m) ~ R15(15m)	—
	X11(11m) ~ X15(15m)	—		R16(16m) ~ R20(20m)	—
	X16(16m) ~ X20(20m)	—			

③ Option

Name	Option code	See page	Standard price
Brake	B	—	—
Non-motor end specification	NM	→P10	—

Actuator Specifications

Item	Description
Drive system	Ball screw ϕ 12mm, rolled C10
Positioning repeatability (*1)	± 0.02 mm [± 0.03]
Lost motion	0.1mm or less
Base	Material: Aluminum with white alumite treatment
Guide	Linear guide
Dynamic allowable moment (*2)	Ma: 10 N·m, Mb: 14.2 N·m, Mc: 28.8 N·m
Allowable overhang	230mm or less in Ma, Mb and Mc directions
Ambient operating temperature, humidity	0 to 40°C, 85% RH or less (Non-condensing)

(*1) The value at lead 24 is shown in [].

(*2) Based on 5,000km of traveling life

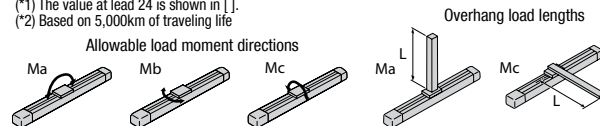

Dimensional Drawings

CAD drawings can be downloaded from the website. www.intelligentactuator.com



*1 During home return, be careful to avoid interference from peripheral objects because the slider travels until the mechanical end.
ME: Mechanical end
SE: Stroke end

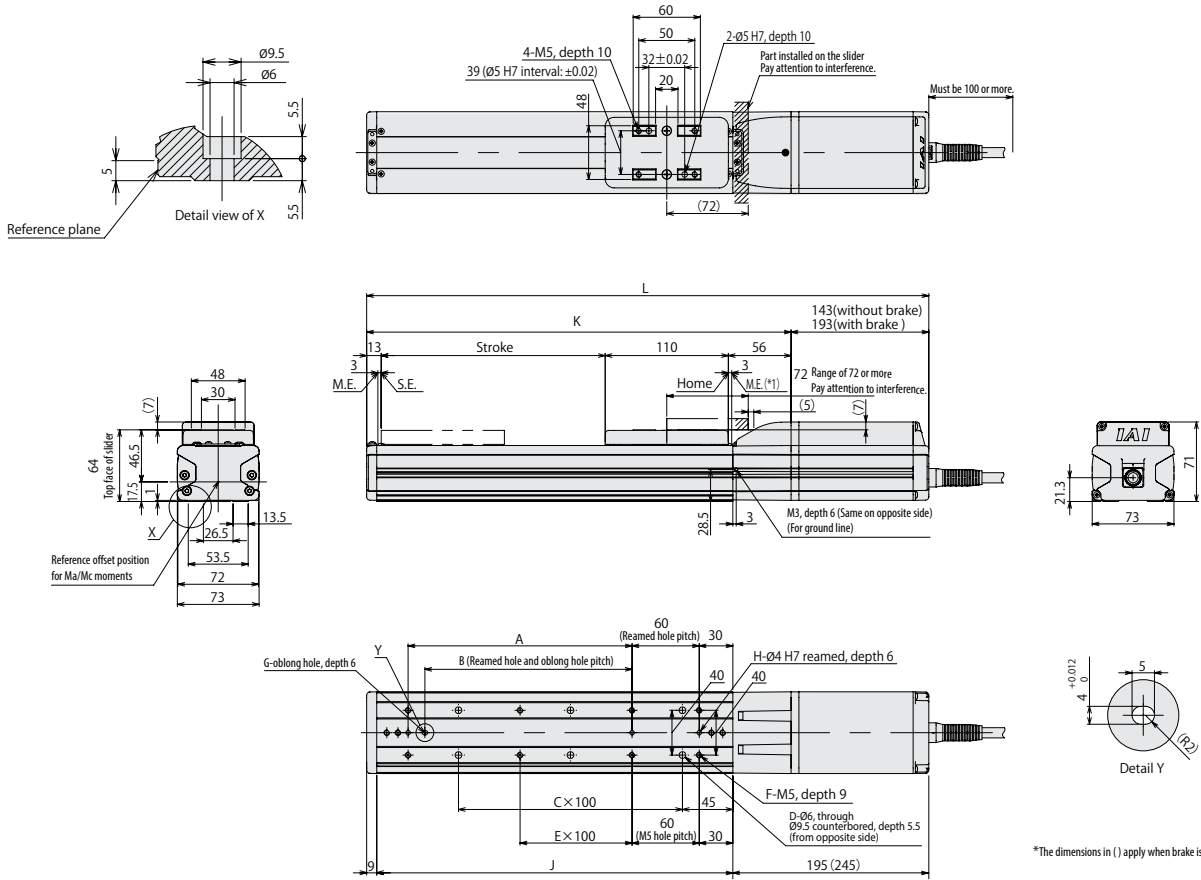

*The dimensions in () apply when brake is equipped.

Dimensions and Mass by Stroke

Stroke	50	100	150	200	250	300	350	400	450	500	550	600	650	700	750	800	
L	Without brake	372	422	472	522	572	622	672	722	772	822	872	922	972	1022	1072	1122
	With brake	422	472	522	572	622	672	722	772	822	872	922	972	1022	1072	1122	1172
A	0	100	100	200	200	300	300	400	400	500	500	600	600	700	700	800	800
B	0	85	85	185	185	285	285	385	385	485	485	585	585	685	685	785	785
C	1	1	2	2	3	3	4	4	5	5	6	6	7	7	8	8	8
D	4	4	6	6	8	8	10	10	12	12	14	14	16	16	18	18	18
E	0	0	0	1	1	2	2	3	3	4	4	5	5	6	6	7	7
F	4	6	6	8	8	10	10	12	12	14	14	16	16	18	18	20	20
G	0	1	1	1	1	1	1	1	1	1	1	1	1	1	1	1	1
H	2	3	3	3	3	3	3	3	3	3	3	3	3	3	3	3	3
J	168	218	268	318	368	418	468	518	568	618	668	718	768	818	868	918	918
K	229	279	329	379	429	479	529	579	629	679	729	779	829	879	929	979	979
Mass (kg)	Without brake	3.0	3.2	3.5	3.7	3.9	4.1	4.4	4.6	4.8	5.0	5.3	5.5	5.7	5.9	6.1	6.4
	With brake	3.5	3.7	4.0	4.2	4.4	4.6	4.9	5.1	5.3	5.5	5.8	6.0	6.2	6.4	6.6	6.9

Applicable Controller

RCP5 series actuators can be operated with the controller indicated below. Select the type according to your intended application.

Name	External view	Model number	Features	Maximum number of positioning points	Input power	Power supply capacity	Standard price	Reference page
Positioner type		PCON-CA-56PWAI-NP-□-□-□-□ PCON-CA-56PWAI-PN-□-□-□-□	Equipped with a high-output driver Positioner type based on PIO control	512 points	DC24V	Refer to P. 46	—	Refer to P. 39
Pulse-train type		PCON-CA-56PWAI-PLN-□-□-□-□ PCON-CA-56PWAI-PLP-□-□-□-□	Equipped with a high-output driver Pulse-train input type	—				
Field network type		PCON-CA-56PWAI-①-□-□-□-□	Equipped with a high-output driver Supporting major field networks	768 points				
Position controller, 8-axis type	MSEP-C-□-56PWAI-□-□-□-□	Positioner type that accepts connection of up to eight axes.	3 points/256 points					
6-axis type with I/O control function	MSEP-LC-□-56PWAI-□-□-□-□	Axes can be moved and I/O signal turned ON/OFF using a ladder logic program.	256 points					

*In the model numbers shown above, ① indicates the field network specification (DV, CC, PR, CN, ML, EC or EP).

RCP5-RA4C

ROBO Cylinder, Rod Type, Motor Unit Coupled, Actuator Width 40mm, 24-V Pulse Motor

Model Specification Items	RCP5 — RA4C — WA — 35P — <input type="checkbox"/> — <input type="checkbox"/> — P3 — <input type="checkbox"/> — <input type="checkbox"/>
	Series — Type — Encoder type — Motor type — Lead — Stroke — Applicable controller — Cable length — Options
	WA : Battery-less absolute specification 35P : Pulse motor, size 35□ 16 : 16mm 10 : 10mm 5 : 5mm 2.5 : 2.5mm 60 : 60mm 410 : 410mm (every 50mm) P3 : PCON-CA MSEP-C/LC N : None P : 1m S : 3m M : 5m X□□ : Specified length R□□ : Robot cable Refer to the options table below.

Built-in guide mechanism

RoHS



POINT
Note on selection

- The payload in "Actuator Specifications" represents the maximum values, but the payload of a specific model varies depending on the acceleration. For details, refer to "Selection Guideline" (Table of RCP5 Payload by Speed/Acceleration) on pp. 33 to 34.
- Refer to P. 31 for the push-motion operation.

Correlation Diagrams of Speed and Payload

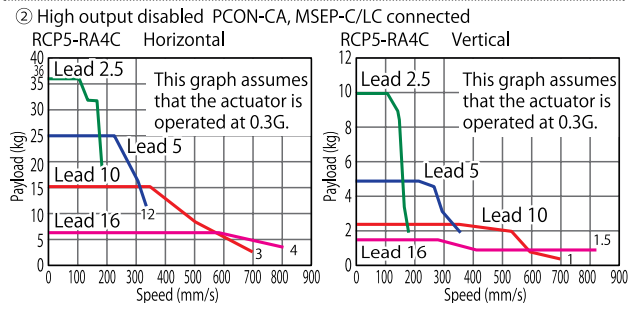
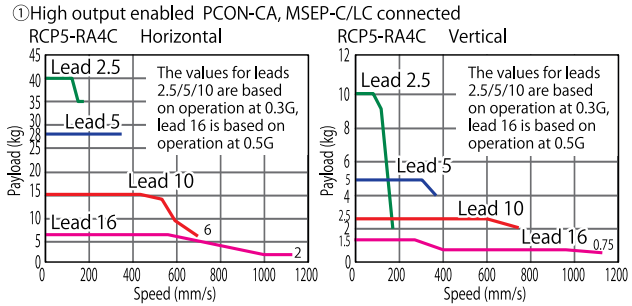

Actuator Specifications

Lead and Payload

Model number	Lead (mm)	Connected controller	Maximum payload		Maximum push force (N)	Stroke (mm)
			Horizontal (kg)	Vertical (kg)		
RCP5-RA4C-WA-35P-16-①-P3-②-③	16	High output enabled PCON-CA MSEP-C/LC	6	1.5	48	60~410 (every 50mm)
		High output disabled PCON-CA MSEP-C/LC				
RCP5-RA4C-WA-35P-10-①-P3-②-③	10	High output enabled PCON-CA MSEP-C/LC	15	2.5	77	
		High output disabled PCON-CA MSEP-C/LC				
RCP5-RA4C-WA-35P-5-①-P3-②-③	5	High output enabled PCON-CA MSEP-C/LC	28	5	155	
		High output disabled PCON-CA MSEP-C/LC				
RCP5-RA4C-WA-35P-2.5-①-P3-②-③	2.5	High output enabled PCON-CA MSEP-C/LC	40	10	310	
		High output disabled PCON-CA MSEP-C/LC				

Code explanation ① Stroke ② Cable length ③ Options

Stroke and Maximum Speed

The values in <> apply when the actuator is used vertically. (unit: mm/s)

Lead (mm)	Connected controller	60~360 (every 50mm)		410 (mm)
		60~360 (every 50mm)	410 (mm)	
16	High output enabled PCON-CA MSEP-C/LC	1120	1080	
	High output disabled PCON-CA MSEP-C/LC			
10	High output enabled PCON-CA MSEP-C/LC	700	685	
	High output disabled PCON-CA MSEP-C/LC			
5	High output enabled PCON-CA MSEP-C/LC	350	340	
	High output disabled PCON-CA MSEP-C/LC			
2.5	High output enabled PCON-CA MSEP-C/LC	175	170	
	High output disabled PCON-CA MSEP-C/LC			

① Stroke

Stroke (mm)	Standard price
60	—
110	—
160	—
210	—
260	—
310	—
360	—
410	—

② Cable Length

Type	Cable symbol	Standard price
Standard type	P (1m)	—
	S (3m)	—
	M (5m)	—
Special length	X06 (6m) ~ X10 (10m)	—
	X11 (11m) ~ X15 (15m)	—
	X16 (16m) ~ X20 (20m)	—
Robot cable	R01 (1m) ~ R03 (3m)	—
	R04 (4m) ~ R05 (5m)	—
	R06 (6m) ~ R10 (10m)	—
	R11 (11m) ~ R15 (15m)	—
	R16 (16m) ~ R20 (20m)	—

③ Option

Name	Option code	See page	Standard price
Brake	B	→ P10	—
Non-motor end specification	NM		—

Actuator Specifications

Item	Description
Drive system	Ball screw ø8mm, rolled C10
Positioning repeatability	±0.02mm
Lost motion	0.1mm or less
Rod	ø20mm Aluminum
Rod non-rotation precision (*1)	±0 deg
Allowable rod load mass	Refer to P. 18 and P. 35
Rod tip overhang distance	100mm or less
Ambient operating temperature, humidity	0 to 40°C, 85% RH or less (Non-condensing)

(*1) Accuracy of rod displacement in rotating direction when no load is received.

Dimensional Drawings

CAD drawings can be downloaded from the website. www.intelligentactuator.com

2D CAD

- *1 During home return, be careful to avoid interference from peripheral objects because the slider travels until the mechanical end.
 - *2 The orientation of the width across flats varies depending on the product.
 - *3 If the actuator is installed using the front housing and flange, make sure the actuator will not receive any external force.
(For details, refer to "Notes on Installing Rod Actuators" on P. 31.)
- ME: Mechanical end
SE: Stroke end

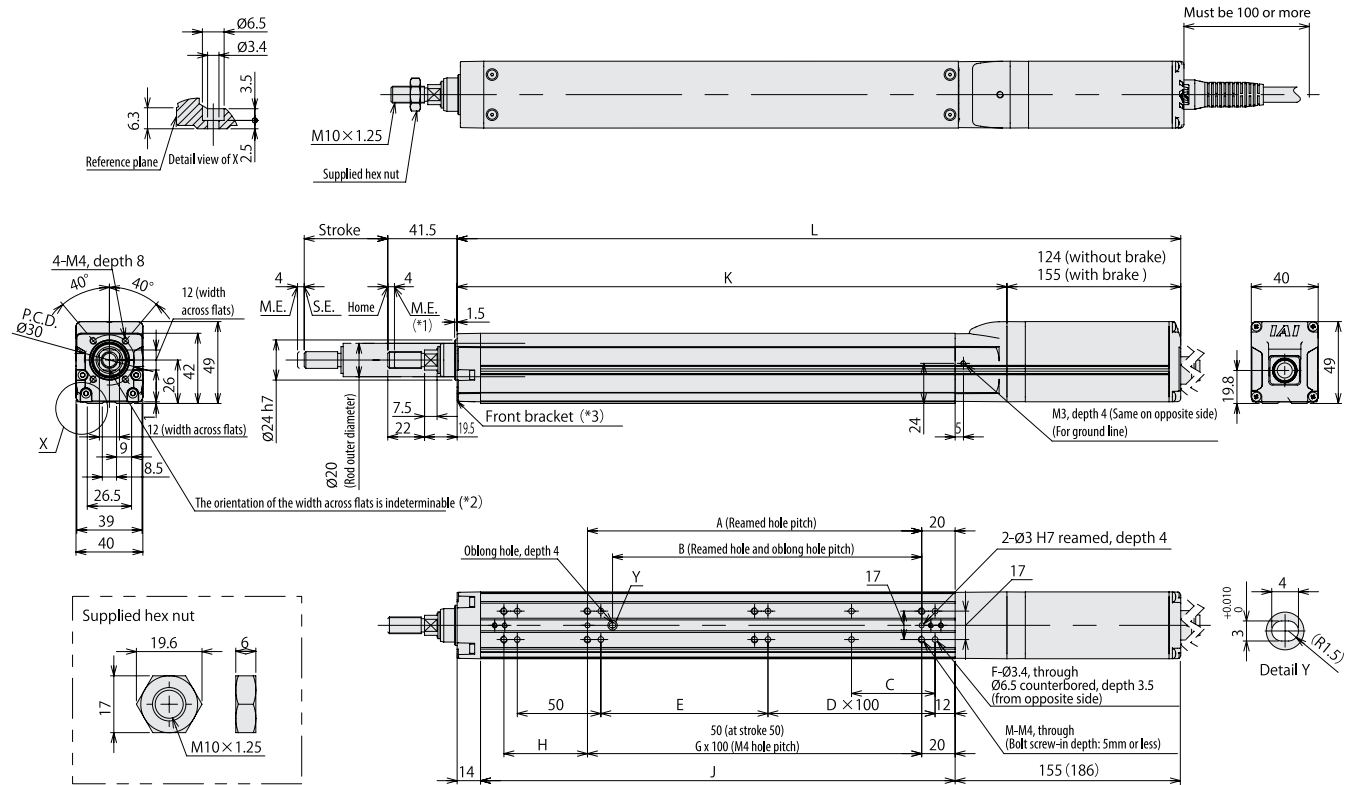

■ Rod Deflection of RCP5-RA4C (Reference Values)

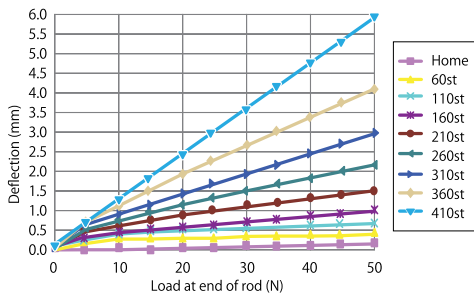

■ Dimensions and Mass by Stroke

*The dimensions in () apply when brake is equipped.

Stroke	60	110	160	210	260	310	360	410	
L	Without brake	303	353	403	453	503	553	603	653
	With brake	334	384	434	484	534	584	634	684
A	50	100	100	200	200	300	300	400	
B	35	85	85	185	185	285	285	385	
C	25	50	50	50	50	50	50	50	
D	0	0	1	1	2	2	3	3	
E	50	100	50	100	50	100	50	100	
F	8	8	10	10	12	12	14	14	
G	-	1	1	2	2	3	3	4	
H	50	50	100	50	100	50	100	50	
J	134	184	234	284	334	384	434	484	
K	179	229	279	329	379	429	479	529	
M	6	6	6	8	8	10	10	12	
Allowable static load at end of rod (N)	55.8	44.6	37.1	31.7	27.6	24.3	21.7	19.5	
Allowable dynamic load at end of rod (N)	Load offset 0mm	25.4	19.5	15.5	12.8	10.8	9.2	7.9	6.9
	Load offset 100mm	16.5	14.5	12.4	10.7	9.2	8.0	7.0	6.2
Allowable static torque at end of rod (N-m)	5.6	4.5	3.8	3.2	2.8	2.5	2.3	2.1	
Allowable dynamic torque at end of rod (N-m)	1.7	1.5	1.2	1.1	0.9	0.8	0.7	0.6	
Mass (kg)	Without brake	1.1	1.2	1.3	1.4	1.6	1.7	1.8	1.9
	With brake	1.3	1.4	1.5	1.6	1.8	1.9	2.0	2.1

Applicable Controller

RCP5 series actuators can be operated with the controller indicated below. Select the type according to your intended application.

Name	External view	Model number	Features	Maximum number of positioning points	Input power	Power supply capacity	Standard price	Reference page
Positioner type		PCON-CA-35PWAI-NP-□-0-□ PCON-CA-35PWAI-PN-□-0-□	Equipped with a high-output driver Positioner type based on PIO control	512 points	DC24V	Refer to P. 46	—	Refer to P. 39
Pulse-train type		PCON-CA-35PWAI-PLN-□-0-□ PCON-CA-35PWAI-PLP-□-0-□	Equipped with a high-output driver Pulse-train input type	—				
Field network type	PCON-CA-35PWAI-Ⓢ-0-0-□	Equipped with a high-output driver Supporting major field networks	768 points					
Position controller, 8-axis type		MSEP-C-□-35PWAI-□-□-0	Positioner type that accepts connection of up to eight axes.	3 points/256 points	Refer to P. 55	Contact IAL	Refer to P. 47	
6-axis type with I/O control function		MSEP-LC-□-35PWAI-□-□-0-□	Axes can be moved and I/O signal turned ON/OFF using a ladder logic program.	256 points				

*In the model numbers shown above, Ⓢ indicates the field network specification (DV, CC, PR, CN, ML, EC or EP).

RCP5-RA6C

ROBO Cylinder, Rod Type, Motor Unit Coupled, Actuator Width 58mm, 24-V Pulse Motor

Model Specification Items	RCP5 — RA6C — WA — 42P — <input type="checkbox"/> — <input type="checkbox"/> — P3 — <input type="checkbox"/> — <input type="checkbox"/>
	Series — Type — Encoder type — Motor type — Lead — Stroke — Applicable controller — Cable length — Options
	WA : Battery-less absolute specification 42P : Pulse motor, size 42 <input type="checkbox"/> 20 : 20mm 12 : 12mm 6 : 6mm 3 : 3mm 65 : 65mm 415 : 415mm (every 50mm) P3 : PCON-CA MSEP-C/LC N : None P : 1m S : 3m M : 5m X <input type="checkbox"/> : Specified length R <input type="checkbox"/> : Robot cable

Built-in guide mechanism

RoHS



POINT
Note on selection

- The payload in "Actuator Specifications" represents the maximum values, but the payload of a specific model varies depending on the acceleration. For details, refer to "Selection Guideline" (Table of RCP5 Payload by Speed/Acceleration) on pp. 33 to 34.
- Refer to P. 31 for the push-motion operation.

Correlation Diagrams of Speed and Payload

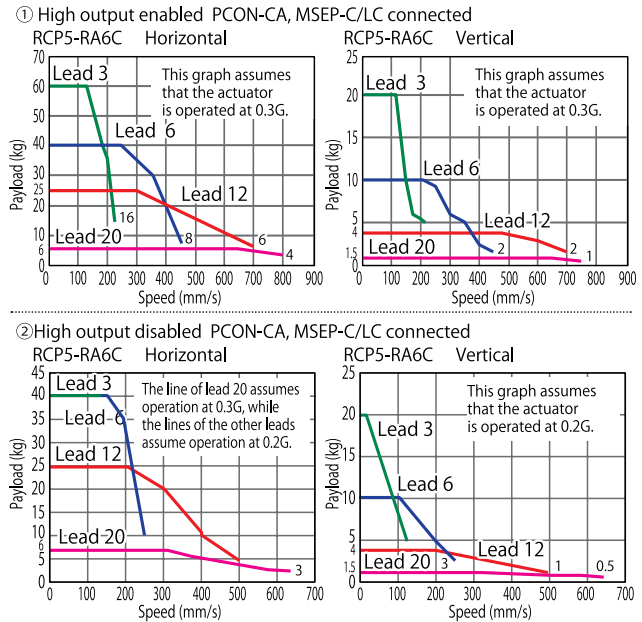

Actuator Specifications

Lead and Payload

Model number	Lead (mm)	Connected controller	Maximum payload		Maximum push force (N)	Stroke (mm)
			Horizontal (kg)	Vertical (kg)		
RCP5-RA6C-WA-42P-20-①-P3-②-③	20	High output enabled PCON-CA MSEP-C/LC High output disabled PCON-CA MSEP-C/LC	6	1.5	56	65~415 (every 50mm)
RCP5-RA6C-WA-42P-12-①-P3-②-③	12	High output enabled PCON-CA MSEP-C/LC High output disabled PCON-CA MSEP-C/LC	25	4	93	
RCP5-RA6C-WA-42P-6-①-P3-②-③	6	High output enabled PCON-CA MSEP-C/LC High output disabled PCON-CA MSEP-C/LC	40	10	185	
RCP5-RA6C-WA-42P-3-①-P3-②-③	3	High output enabled PCON-CA MSEP-C/LC	60	20	370	
		High output disabled PCON-CA MSEP-C/LC	40			

Code explanation ① Stroke ② Cable length ③ Options

Stroke and Maximum Speed

Lead (mm)	Connected controller	Maximum speed (unit: mm/s)	
		65~365 (every 50mm)	415 (mm)
20	High output enabled PCON-CA MSEP-C/LC	800	
	High output disabled PCON-CA MSEP-C/LC	640	
12	High output enabled PCON-CA MSEP-C/LC	700	
	High output disabled PCON-CA MSEP-C/LC	500	
6	High output enabled PCON-CA MSEP-C/LC	450	
	High output disabled PCON-CA MSEP-C/LC	250	
3	High output enabled PCON-CA MSEP-C/LC	225	220
	High output disabled PCON-CA MSEP-C/LC	125	

① Stroke

Stroke (mm)	Standard price	Stroke (mm)	Standard price
65	—	265	—
115	—	315	—
165	—	365	—
215	—	415	—

② Cable Length

Type	Cable symbol	Standard price
Standard type	P (1m)	—
	S (3m)	—
	M (5m)	—
Special length	X06 (6m) ~ X10 (10m)	—
	X11 (11m) ~ X15 (15m)	—
	X16 (16m) ~ X20 (20m)	—
Robot cable	R01 (1m) ~ R03 (3m)	—
	R04 (4m) ~ R05 (5m)	—
	R06 (6m) ~ R10 (10m)	—
	R11 (11m) ~ R15 (15m)	—
	R16 (16m) ~ R20 (20m)	—

③ Option

Name	Option code	See page	Standard price
Brake	B	→P.10	—
Non-motor end specification	NM		—

Actuator Specifications

Item	Description
Drive system	Ball screw ϕ 10mm, rolled C10
Positioning repeatability (*1)	\pm 0.02mm [\pm 0.03mm]
Lost motion	0.1mm or less
Rod	ϕ 25mm Aluminum
Rod non-rotation precision (*2)	\pm 0 deg
Allowable rod load mass	Refer to P. 20 and P. 35
Rod tip overhang distance	100mm or less
Ambient operating temperature, humidity	0 to 40°C, 85% RH or less (Non-condensing)

(*1) The value at lead 20 is shown in [.] (*2) Accuracy of rod displacement in rotating direction when no load is received.

Dimensional Drawings

CAD drawings can be downloaded from the website. www.intelligentactuator.com

2D CAD

- *1 During home return, be careful to avoid interference from peripheral objects because the slider travels until the mechanical end.
 - *2 The orientation of width across flats varies depending on the product.
 - *3 If the actuator is installed using the front housing and flange, make sure the actuator will not receive any external force.
(For details, refer to "Notes on Installing Rod Actuators" on P. 31.)
- ME: Mechanical end
SE: Stroke end

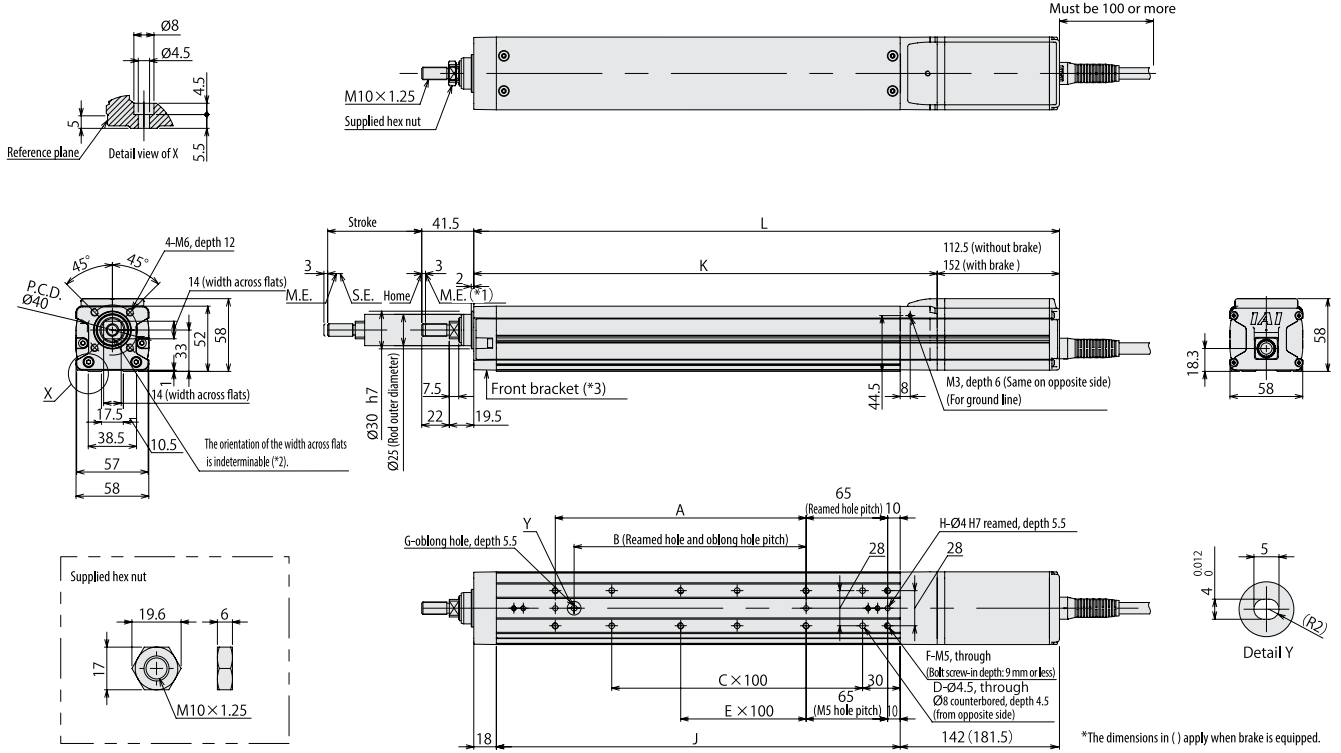

■ Rod Deflection of RCP5-RA6C (Reference Values)

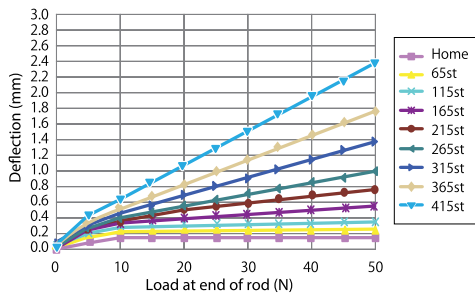

■ Dimensions and Mass by Stroke

Stroke	65	115	165	215	265	315	365	415	
L	Without brake	332	382	432	482	532	582	632	682
	With brake	371.5	421.5	471.5	521.5	571.5	621.5	671.5	721.5
A	0	100	100	200	200	300	300	400	
B	0	85	85	185	185	285	285	385	
C	1	1	2	2	3	3	4	4	
D	4	4	6	6	8	8	10	10	
E	0	0	0	1	1	2	2	3	
F	4	6	6	8	8	10	10	12	
G	0	1	1	1	1	1	1	1	
H	2	3	3	3	3	3	3	3	
J	172	222	272	322	372	422	472	522	
K	219.5	269.5	319.5	369.5	419.5	469.5	519.5	569.5	
Allowable static load at end of rod (N)	Load offset 0mm	113.8	92.6	78.0	67.3	59.0	52.5	47.2	42.8
	Load offset 100mm	45.7	36.3	29.8	25.1	21.6	18.8	16.6	14.7
Allowable dynamic load at end of rod (N)	Load offset 0mm	32.1	28.3	24.6	21.5	18.9	16.7	14.9	13.4
	Load offset 100mm	11.5	9.4	7.9	6.8	6.0	5.4	4.9	4.5
Allowable static torque at end of rod (N-m)	Load offset 0mm	3.2	2.8	2.5	2.1	1.9	1.7	1.5	1.3
	Load offset 100mm	1.8	2.0	2.2	2.4	2.6	2.9	3.1	3.3
Mass (kg)	Without brake	1.8	2.0	2.2	2.4	2.6	2.9	3.1	3.3
	With brake	2.0	2.2	2.4	2.6	2.8	3.1	3.3	3.5

Applicable Controller

RCP5 series actuators can be operated with the controller indicated below. Select the type according to your intended application.

Name	External view	Model number	Features	Maximum number of positioning points	Input power	Power supply capacity	Standard price	Reference page			
Positioner type		PCON-CA-42PWAI-NP-□-0-□ PCON-CA-42PWAI-PN-□-0-□	Equipped with a high-output driver Positioner type based on PIO control	512 points	DC24V	Refer to P. 46	—	Refer to P. 39			
Pulse-train type		PCON-CA-42PWAI-PLN-□-0-□ PCON-CA-42PWAI-PLP-□-0-□	Equipped with a high-output driver Pulse-train input type	—							
Field network type		PCON-CA-42PWAI-□-0-0-□	Equipped with a high-output driver Supporting major field networks	768 points							
Position controller, 8-axis type		MSEP-C-□-42PWAI-□-□-0	Positioner type that accepts connection of up to eight axes.	3 points/256 points					Refer to P. 55	Contact IAI.	Refer to P. 47
6-axis type with I/O control function		MSEP-LC-□-42PWAI-□-□-0-□	Axes can be moved and I/O signal turned ON/OFF using a ladder logic program.	256 points							

*In the model numbers shown above, □ indicates the field network specification (DV, CC, PR, CN, ML, EC or EP).

RCP5-RA7C

ROBO Cylinder, Rod Type, Motor Unit Coupled, Actuator Width 73mm, 24-V Pulse Motor

Model Specification Items	RCP5	RA7C	WA	56P			P3		
	Series	Type	Encoder type	Motor type	Lead	Stroke	Applicable controller	Cable length	Options
			WA : Battery-less absolute specification	56P : Pulse motor, size 56□	24 : 24mm 16 : 16mm 8 : 8mm 4 : 4mm	70 : 70mm 520 : 520mm (every 50mm)	P3 : PCON-CA MSEP-C/LC	N : None P : 1m S : 3m M : 5m X□ : Specified length R□ : Robot cable	Refer to the options table below.

Built-in guide mechanism

RoHS



Correlation Diagrams of Speed and Payload

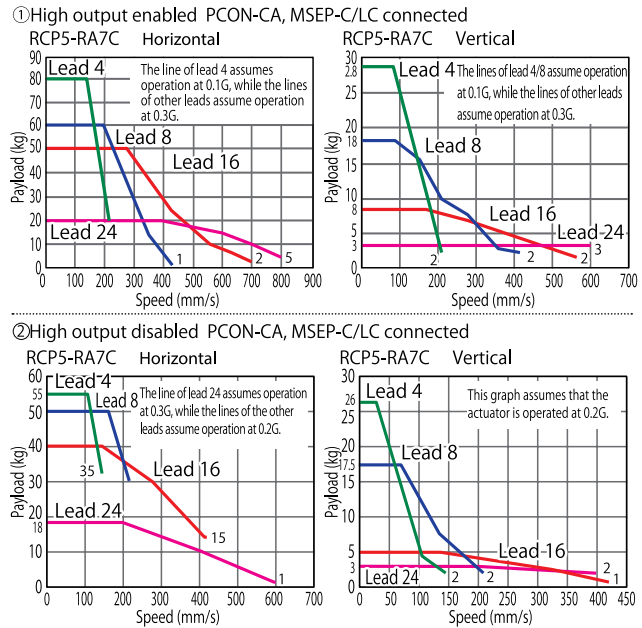

POINT
Note on selection

(1) The payload in "Actuator Specifications" represents the maximum values, but the payload of a specific model varies depending on the acceleration. For details, refer to "Selection Guideline" (Table of RCP5 Payload by Speed/Acceleration) on pp. 33 to 34.

(2) Refer to P. 31 for the push-motion operation.

Actuator Specifications

Lead and Payload

Model number	Lead (mm)	Connected controller	Maximum payload (kg)		Maximum push force (N)	Stroke (mm)
			Horizontal	Vertical		
RCP5-RA7C-WA-56P-24-①-P3-②-③	24	High output enabled PCON-CA MSEP-C/LC	20	3	182	70~520 (every 50mm)
		High output disabled PCON-CA MSEP-C/LC	18	3		
RCP5-RA7C-WA-56P-16-①-P3-②-③	16	High output enabled PCON-CA MSEP-C/LC	50	8	273	
		High output disabled PCON-CA MSEP-C/LC	40	5		
RCP5-RA7C-WA-56P-8-①-P3-②-③	8	High output enabled PCON-CA MSEP-C/LC	60	18	547	
		High output disabled PCON-CA MSEP-C/LC	50	17.5		
RCP5-RA7C-WA-56P-4-①-P3-②-③	4	High output enabled PCON-CA MSEP-C/LC	80	28	1094	
		High output disabled PCON-CA MSEP-C/LC	55	26		

Code explanation ① Stroke ② Cable length ③ Options

Stroke and Maximum Speed

The values in <> apply when the actuator is used vertically. (unit: mm/s)

Lead (mm)	Connected controller	70~520 (every 50mm)	
		Horizontal	Vertical
24	High output enabled PCON-CA MSEP-C/LC	800	<600>
	High output disabled PCON-CA MSEP-C/LC	600	<400>
16	High output enabled PCON-CA MSEP-C/LC	700	<560>
	High output disabled PCON-CA MSEP-C/LC	420	
8	High output enabled PCON-CA MSEP-C/LC	420	
	High output disabled PCON-CA MSEP-C/LC	210	
4	High output enabled PCON-CA MSEP-C/LC	210	
	High output disabled PCON-CA MSEP-C/LC	140	

① Stroke

Stroke (mm)	Standard price	Stroke (mm)	Standard price
70	—	320	—
120	—	370	—
170	—	420	—
220	—	470	—
270	—	520	—

② Cable Length

Type	Cable symbol	Standard price
Standard type	P (1m)	—
	S (3m)	—
	M (5m)	—
Special length	X06 (6m) ~ X10 (10m)	—
	X11 (11m) ~ X15 (15m)	—
	X16 (16m) ~ X20 (20m)	—
Robot cable	R01 (1m) ~ R03 (3m)	—
	R04 (4m) ~ R05 (5m)	—
	R06 (6m) ~ R10 (10m)	—
	R11 (11m) ~ R15 (15m)	—
	R16 (16m) ~ R20 (20m)	—

③ Option

Name	Option code	See page	Standard price
Brake	B		—
Non-motor end specification	NM	→P.10	—

Actuator Specifications

Item	Description
Drive system	Ball screw ø12mm, rolled C10
Positioning repeatability (*1)	±0.02mm [±0.03mm]
Lost motion	0.1mm or less
Rod	ø30mm Aluminum
Rod non-rotation precision (*2)	±0 deg
Allowable rod load mass	Refer to P. 22 and P. 35
Rod tip overhang distance	100mm or less
Ambient operating temperature, humidity	0 to 40°C, 85% RH or less (Non-condensing)

(*1) The value at lead 24 is shown in []. (*2) Accuracy of rod displacement in rotating direction when no load is received.

Dimensional Drawings

CAD drawings can be downloaded from the website.

www.intelligentactuator.com

2D CAD

- *1 During home return, be careful to avoid interference from peripheral objects because the slider travels until the mechanical end.
 - *2 The orientation of the width across flats varies depending on the product.
 - *3 If the actuator is installed using the front housing and flange, make sure the actuator will not receive any external force.
(For details, refer to "Notes on Installing Rod Actuators" on P. 31.)
- ME: Mechanical end
SE: Stroke end

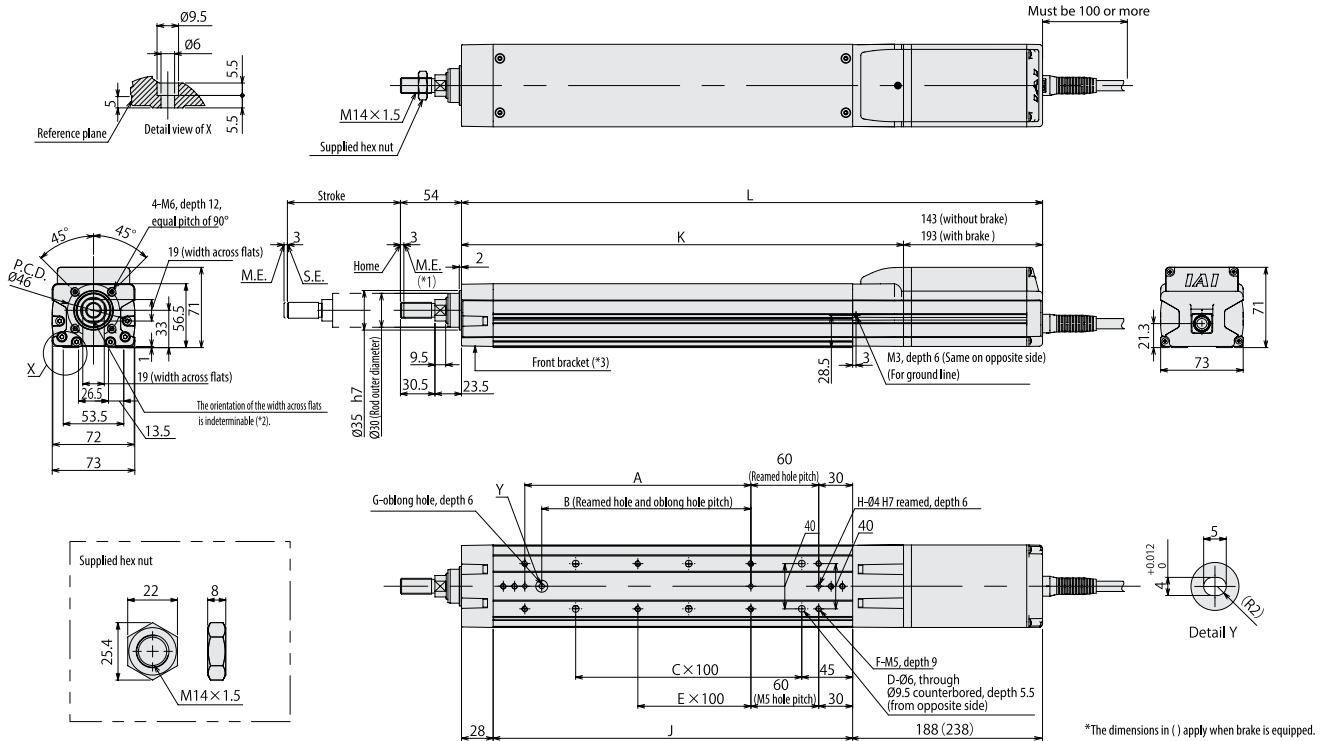

■ Rod Deflection of RCP5-RA7C (Reference Values)

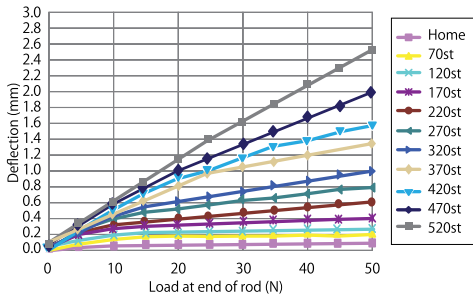

■ Dimensions and Mass by Stroke

Stroke	Stroke										
	70	120	170	220	270	320	370	420	470	520	
L	Without brake	384	434	484	534	584	634	684	734	784	834
	With brake	434	484	534	584	634	684	734	784	834	884
A	0	100	100	200	200	300	300	400	400	500	
B	0	85	85	185	185	285	285	385	385	485	
C	1	1	2	2	3	3	4	4	5	5	
D	4	4	6	6	8	8	10	10	12	12	
E	0	0	0	1	1	2	2	3	3	4	
F	4	6	6	8	8	10	10	12	12	14	
G	0	1	1	1	1	1	1	1	1	1	
H	2	3	3	3	3	3	3	3	3	3	
J	168	218	268	318	368	418	468	518	568	618	
K	241	291	341	391	441	491	541	591	641	691	
Allowable static load at end of rod (N)	119.2	97.7	82.8	71.6	63.0	56.2	50.6	46.0	42.2	38.8	
Allowable dynamic load at end of rod (N)	Load offset 0mm	44.3	35.7	29.6	25.2	21.7	19.0	16.8	15.0	13.6	12.2
	Load offset 100mm	33.9	29.7	25.7	22.4	19.7	17.4	15.5	14.0	12.8	11.5
Allowable static torque at end of rod (N-m)	12.1	10.0	8.5	7.4	6.5	5.9	5.3	4.9	4.5	4.1	
Allowable dynamic torque at end of rod (N-m)	Without brake	3.3	3.0	2.6	2.2	2.0	1.7	1.6	1.4	1.3	1.2
	With brake	3.3	3.6	3.9	4.2	4.5	4.8	5.1	5.4	5.6	5.9
Mass (kg)	Without brake	3.8	4.1	4.4	4.7	5.0	5.3	5.6	5.9	6.1	6.4
	With brake	3.8	4.1	4.4	4.7	5.0	5.3	5.6	5.9	6.1	6.4

Applicable Controller

RCP5 series actuators can be operated with the controller indicated below. Select the type according to your intended application.

Name	External view	Model number	Features	Maximum number of positioning points	Input power	Power supply capacity	Standard price	Reference page
Positioner type		PCON-CA-56PWAI-NP-□-□-□-□ PCON-CA-56PWAI-PN-□-□-□-□	Equipped with a high-output driver Positioner type based on PIO control	512 points	DC24V	Refer to P. 46	—	Refer to P. 39
Pulse-train type		PCON-CA-56PWAI-PLN-□-□-□-□ PCON-CA-56PWAI-PLP-□-□-□-□	Equipped with a high-output driver Pulse-train input type	—				
Field network type		PCON-CA-56PWAI-①-□-□-□-□	Equipped with a high-output driver Supporting major field networks	768 points				
Position controller, 8-axis type	MSEP-C-□-56PWAI-□-□-□-□	Positioner type that accepts connection of up to eight axes.	3 points/256 points	Refer to P. 55			Contact IAL	Refer to P. 47
6-axis type with I/O control function	MSEP-LC-□-56PWAI-□-□-□-□	Axes can be moved and I/O signal turned ON/OFF using a ladder logic program.	256 points					

* In the model numbers shown above, ① indicates the field network specification (DV, CC, PR, CN, ML, EC or EP).

RCP5-RA8C

ROBO Cylinder, High-thrust Rod Type, Motor Unit Coupled, Actuator Width 88mm, 24-V Pulse Motor

Model Specification Items	RCP5	RA8C	WA	60P			P4		
	Series	Type	Encoder type	Motor type	Lead	Stroke	Applicable controller	Cable length	Options
			WA : Battery-less absolute specification	60P : Pulse motor, size 60□	20 : 20mm 10 : 10mm 5 : 5mm	50 : 50mm 700 : 700mm (every 50mm)	P4 : PCON-CFA	N : None P : 1m S : 3m M : 5m X□□ : Specified length R□□ : Robot cable	Refer to the options table below.

Built-in guide mechanism

RoHS

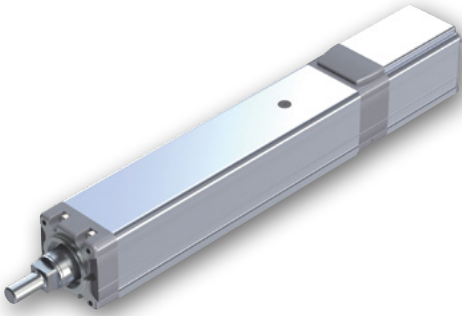

POINT
Note on selection

- The payload assumes operation at an acceleration of 0.1G for lead 5 and operation at an acceleration of 0.2G for lead 10 and lead 20. The above values are the upper limits of acceleration/deceleration.
- Exercise caution that the RA8C requires a dedicated controller (high-thrust PCON-CFA).

Correlation Diagrams of Speed and Payload

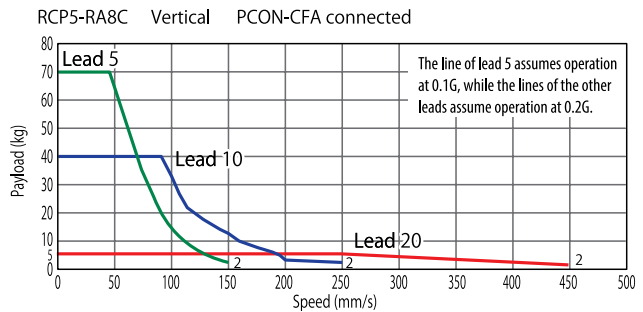
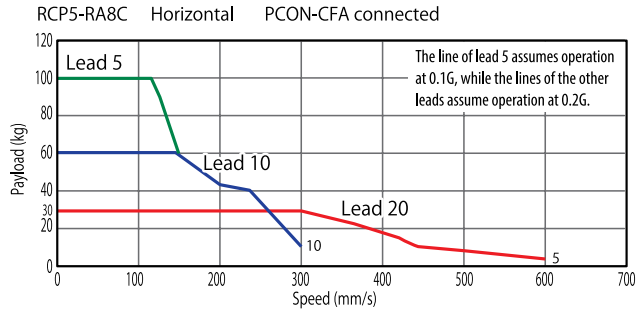

Actuator Specifications

Lead and Payload

Model number	Lead (mm)	Connected controller	Maximum payload		Maximum push force (N)	Stroke (mm)
			Horizontal (kg)	Vertical (kg)		
RCP5-RA8C-WA-60P-20-①-P4-②-③	20	PCON-CFA	30	5	500	50~700 (every 50mm)
RCP5-RA8C-WA-60P-10-①-P4-②-③	10	PCON-CFA	60	40	1000	
RCP5-RA8C-WA-60P-5-①-P4-②-③	5	PCON-CFA	100	70	2000	

Code explanation ① Stroke ② Cable length ③ Options

Stroke and Maximum Speed

The values in <-> apply when the actuator is used vertically. (unit: mm/s)

Lead (mm)	50 (mm)	100 (mm)	150 (mm)	200 (mm)	250~350 (mm)	400 (mm)	450 (mm)	500 (mm)	550 (mm)	600 (mm)	650 (mm)	700 (mm)
20	280	405	505 <450>	585 <450>	600 <450>	520 <450>	440	360	320	280	240	220
10	280 <250>			300 <250>		280 <250>	220	180	160	140	120	110
5			150			130	110	90	80	70	60	55

① Stroke

Stroke (mm)	Standard price	Stroke (mm)	Standard price
50	Contact IAI.	400	Contact IAI.
100		450	
150		500	
200		550	
250		600	
300		650	
350		700	

② Cable Length

Type	Cable symbol	Standard price
Standard type	P (1m)	—
	S (3m)	—
	M (5m)	—
	X06 (6m) ~ X10 (10m)	—
Special length	X11 (11m) ~ X15 (15m)	—
	X16 (16m) ~ X20 (20m)	—
	R01 (1m) ~ R03 (3m)	—
Robot cable	R04 (4m) ~ R05 (5m)	—
	R06 (6m) ~ R10 (10m)	—
	R11 (11m) ~ R15 (15m)	—
	R16 (16m) ~ R20 (20m)	—

③ Option

Name	Option code	See page	Standard price
Brake	B	→P.10	Contact IAI.
Optional cable exit direction (top)	CJT		
Optional cable exit direction (right)	CJR		
Optional cable exit direction (left)	CJL		
Optional cable exit direction (bottom)	CJB		
Flange bracket	FL		
Non-motor end specification	NM		

Actuator Specifications

Item	Description
Drive system	Ball screw ø16mm, rolled C10
Positioning repeatability	±0.02mm
Lost motion	0.1mm or less
Rod	ø40mm Aluminum
Rod non-rotation precision (*1)	±0 deg
Allowable rod load mass	Refer to P. 24 and P. 35
Rod tip overhang distance	100mm or less
Ambient operating temperature, humidity	0 to 40°C, 85% RH or less (Non-condensing)

(*1) Accuracy of rod displacement in rotating direction when no load is received.

RCP5-RA10C

ROBO Cylinder, High-thrust Rod Type, Motor Unit Coupled, Actuator Width 108mm, 24-V Pulse Motor

Model Specification Items	RCP5 — RA10C — WA — 86P — <input type="checkbox"/> — <input type="checkbox"/> — P4 — <input type="checkbox"/> — <input type="checkbox"/>	Series	Type	Encoder type	Motor type	Lead	Stroke	Applicable controller	Cable length	Options
	WA : Battery-less absolute specification	86P : Pulse motor, size 86□	10 : 10mm 5 : 5mm 2.5 : 2.5mm	50 : 50mm 1	800 : 800mm (every 50mm)	P4 : PCON-CFA	N : None P : 1m S : 3m M : 5m X□□ : Specified length R□□ : Robot cable	Refer to the options table below.		

Built-in guide mechanism

RoHS

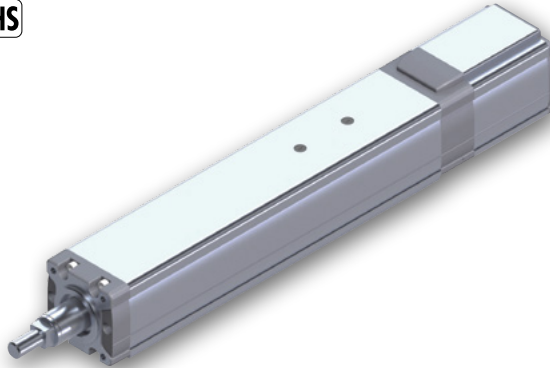

POINT
Note on selection

- The payload assumes operation at an acceleration of 0.01G for lead 2.5, operation at an acceleration of 0.02G for lead 5 and operation at an acceleration of 0.04G for lead 10. The above values are the upper limits of acceleration/deceleration.
- Exercise caution that the RA10C requires a dedicated controller (high-thrust PCON-CFA).

Correlation Diagrams of Speed and Payload

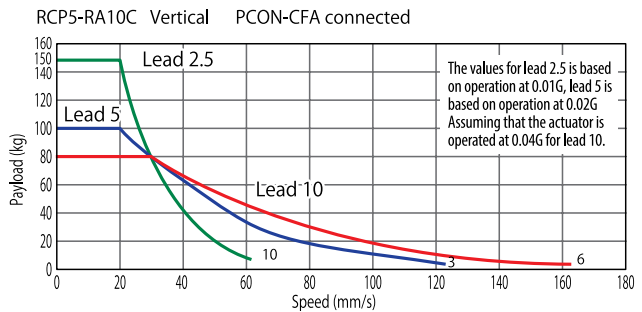
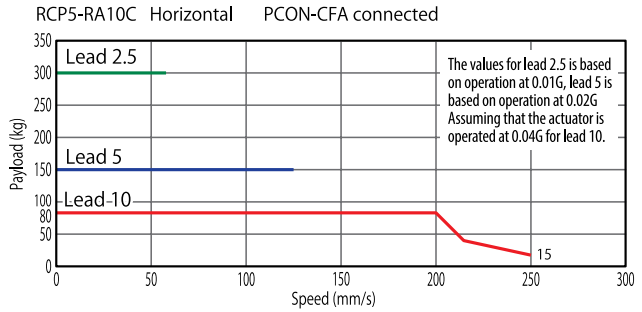

Actuator Specifications

Lead and Payload

Model number	Lead (mm)	Connected controller	Maximum payload		Maximum push force (N)	Stroke (mm)
			Horizontal (kg)	Vertical (kg)		
RCP5-RA10C-WA-86P-10-①-P4-②-③	10	PCON-CFA	80	80	1500	50~800 (every 50mm)
RCP5-RA10C-WA-86P-5-①-P4-②-③	5	PCON-CFA	150	100	3000	
RCP5-RA10C-WA-86P-2.5-①-P4-②-③	2.5	PCON-CFA	300	150	6000	

Code explanation ① Stroke ② Cable length ③ Options

Stroke and Maximum Speed

The values in <> apply when the actuator is used vertically. (unit: mm/s)

Lead (mm)	50 (mm)	100 (mm)	150 (mm)	200~400 (every 50mm)	450 (mm)	500 (mm)	550 (mm)	600 (mm)	650 (mm)	700 (mm)	750 (mm)	800 (mm)
10	117	167	200	<167>	250	<167>	220	200	180	160	140	120
5	83		125		110	90	80	70	60	55	50	45
2.5			63				55	50	45	40	35	30

① Stroke

Stroke (mm)	Standard price	Stroke (mm)	Standard price
50	Contact IAL.	450	Contact IAL.
100		500	
150		550	
200		600	
250		650	
300		700	
350		750	
400		800	

② Cable Length

Type	Cable symbol	Standard price
Standard type	P (1m)	—
	S (3m)	—
	M (5m)	—
Special length	X06 (6m) ~ X10 (10m)	—
	X11 (11m) ~ X15 (15m)	—
	X16 (16m) ~ X20 (20m)	—
Robot cable	R01 (1m) ~ R03 (3m)	—
	R04 (4m) ~ R05 (5m)	—
	R06 (6m) ~ R10 (10m)	—
	R11 (11m) ~ R15 (15m)	—
	R16 (16m) ~ R20 (20m)	—

③ Option

Name	Option code	See page	Standard price
Brake	B	→P.10	Contact IAL.
Optional cable exit direction (top)	CJT		
Optional cable exit direction (right)	CJR		
Optional cable exit direction (left)	CJL		
Optional cable exit direction (bottom)	CJB		
Flange bracket	FL		
Non-motor end specification	NM		

Actuator Specifications

Item	Description
Drive system	Ball screw Ø20mm (lead 2.5/10mm), Ø16mm (lead 5mm), rolled C10
Positioning repeatability	±0.02mm
Lost motion	0.1mm or less
Rod	Ø40mm Aluminum
Rod non-rotation precision (*1)	±0 deg
Allowable rod load mass	Refer to P. 26 and P. 35
Rod tip overhang distance	100mm or less
Ambient operating temperature, humidity	0 to 40°C, 85% RH or less (Non-condensing)

(*1) Accuracy of rod displacement in rotating direction when no load is received.

Dimensional Drawings

CAD drawings can be downloaded from the website. www.intelligentactuator.com



- During home return, be careful to avoid interference from peripheral objects because the slider travels until the mechanical end.
 - The orientation of the width across flats varies depending on the product.
 - If the actuator is installed using the front housing and flange, make sure the actuator will not receive any external force. (For details, refer to "Notes on Installing Rod Actuators" on P. 31.)
- ME: Mechanical end
SE: Stroke end

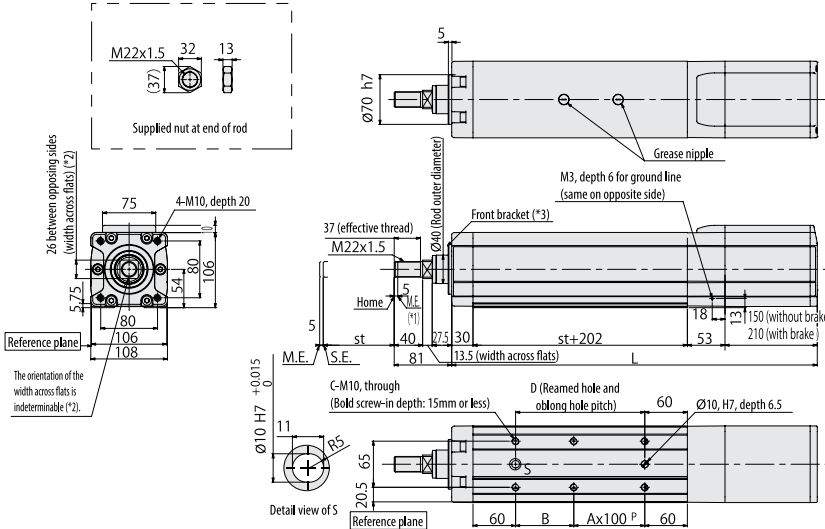

Dimensions with Flange (Optional)

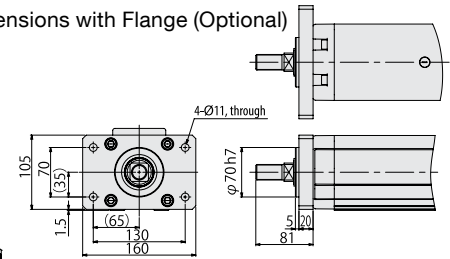

4 Cable Exit Directions (Optional)

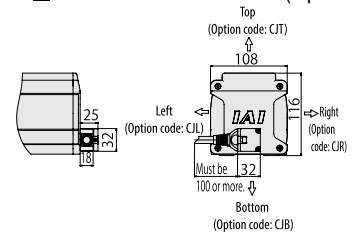

Rod Deflection of RCP5-RA10C

(The graph below shows the measurements of how much a horizontally installed rod would deflect when a load is applied to the end of the rod. The measured deflection include the deflection due to the weight of the rod.)

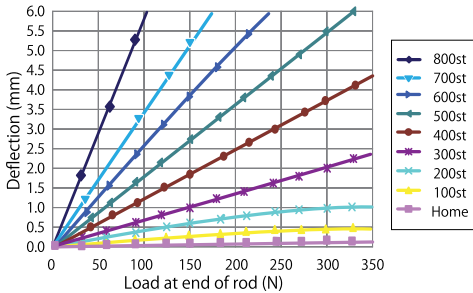

Dimensions and Mass by Stroke

Stroke	Stroke																
	50	100	150	200	250	300	350	400	450	500	550	600	650	700	750	800	
L	Without brake	485	535	585	635	685	735	785	835	885	935	985	1035	1085	1135	1185	1235
	With brake	545	595	645	695	745	795	845	895	945	995	1045	1095	1145	1195	1245	1295
A	0	1	1	2	2	3	3	4	4	5	5	6	6	7	7	8	
B	132	82	132	82	132	82	132	82	132	82	132	82	132	82	132	82	
C	4	6	6	8	8	10	10	12	12	14	14	16	16	18	18	20	
D	132	182	232	282	332	382	432	482	532	582	632	682	732	782	832	882	
Allowable static load at end of rod (N)	Load offset 0mm	316.9	268.4	232.6	205.1	183.4	165.7	151.0	138.6	128.1	119.0	111.0	103.9	97.7	92.1	87.0	82.5
	Load offset 100mm	119.1	99.1	84.7	73.8	65.3	58.5	52.8	48.1	44.0	40.5	37.5	34.8	32.4	30.2	28.3	26.5
Allowable dynamic load at end of rod (N)	Load offset 0mm	100.7	85.9	74.9	66.3	59.3	53.6	48.8	44.7	41.2	38.1	35.4	32.9	30.8	28.8	27.0	25.4
	Load offset 100mm	31.8	27.0	23.4	20.7	18.5	16.8	15.3	14.1	13.1	12.2	11.4	10.7	10.1	9.6	9.1	8.6
Allowable dynamic torque at end of rod (N·m)	Load offset 0mm	10.1	8.6	7.5	6.6	5.9	5.4	4.9	4.5	4.1	3.8	3.5	3.3	3.1	2.9	2.7	2.5
	Load offset 100mm	3.1	2.7	2.3	2.0	1.8	1.6	1.5	1.4	1.3	1.2	1.1	1.0	0.9	0.8	0.7	0.6
Mass (kg)	Without brake	11.5	12.2	12.9	13.6	14.3	15	15.7	16.4	17.1	17.8	18.5	19.2	19.9	20.6	21.3	22
	With brake	13.1	13.8	14.5	15.2	15.9	16.6	17.3	18	18.7	19.4	20.1	20.8	21.5	22.2	22.9	23.6

Correlation Diagrams of Vertical Load and Traveling Life

- Since the RCP5-RA10C has a greater maximum thrust than other types, its service life varies significantly depending on the payload and push force applied when the actuator is installed vertically. When selecting an appropriate type from the correlation diagram of speed and payload or correlation diagram of push force and current-limiting value, check its traveling life on the correlation diagram of payload and service life as well as on the correlation diagram of push force and service life.

Note

The rated value represents the maximum value at a traveling life of 5,000km. The greatest value is the maximum value at which the actuator can operate. Take note that, if an actuator is operated beyond its rating, its service life will drop as shown by the applicable graph on the right.

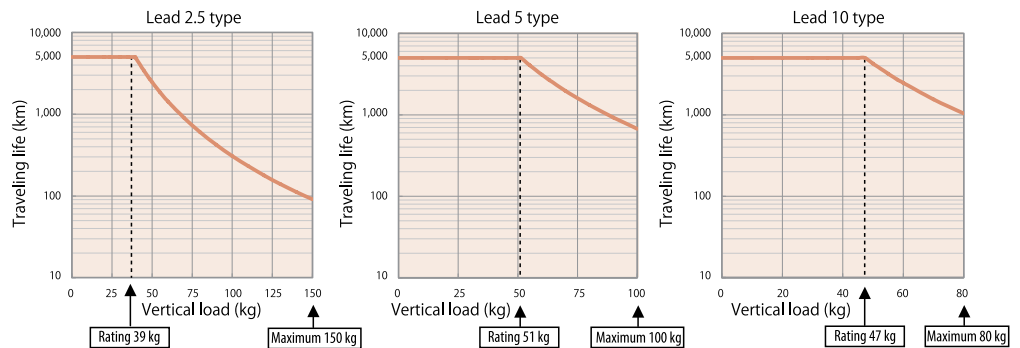

Applicable Controller

RCP5 series actuators can be operated with the controller indicated below. Select the type according to your intended application.

Name	External view	Model number	Features	Maximum number of positioning points	Input power	Power supply capacity	Standard price	Reference page
Positioner type		PCON-CFA-86PWAI-NP-□-□-□	Positioner type based on PIO control	512 points	DC24V	Refer to P. 46	—	Refer to P. 39
Pulse-train type		PCON-CFA-86PWAI-PN-□-□-□						
Field network type		PCON-CFA-86PWAI-PLP-□-□-□	Supporting major field networks	768 points				

*In the model numbers shown above, ① indicates the field network specification (DV, CC, PR, CN, ML, EC or EP).

RCP5-RA8R

ROBO Cylinder, High-thrust Rod Type, Side Mounted Motor Type, Actuator Width 88mm, 24-V Pulse Motor

Model Specification Items	RCP5 — Series	RA8R — Type	WA — Encoder type	60P — Motor type	Lead	Stroke	P4 — Applicable controller	Cable length	Options
			WA : Battery-less absolute specification	60P : Pulse motor, size 60 □	20 : 20mm 10 : 10mm 5 : 5mm	50 : 50mm 700 : 700mm (every 50mm)	P4 : PCON-CFA	N : None P : 1m S : 3m M : 5m X □ □ : Specified length R □ □ : Robot cable	Refer to the options table below.

Built-in guide mechanism

RoHS

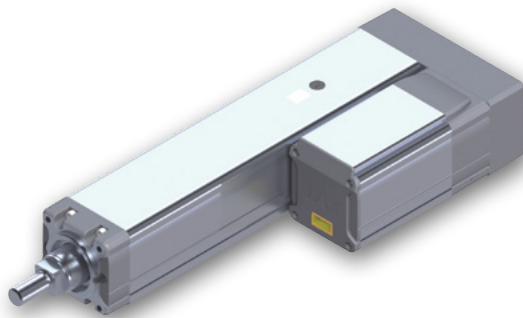

POINT
Note on selection

- (1) The payload assumes operation at an acceleration of 0.1G for lead 5 and operation at an acceleration of 0.2G for lead 10 and lead 20. The above values are the upper limits of acceleration/deceleration.
- (2) Exercise caution that the RA8R requires a dedicated controller (high-thrust PCON-CFA).

Correlation Diagrams of Speed and Payload

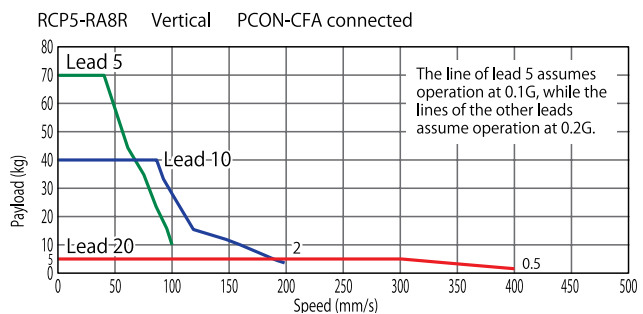
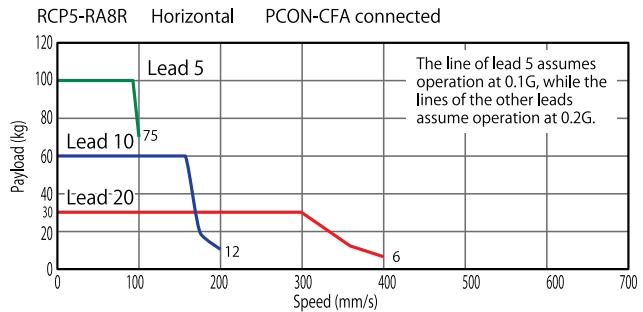

Actuator Specifications

Lead and Payload

Model number	Lead (mm)	Connected controller	Maximum payload		Maximum push force (N)	Stroke (mm)
			Horizontal (kg)	Vertical (kg)		
RCP5-RA8R-WA-60P-20-①-P4-②-③	20	PCON-CFA	30	5	500	50~700 (every 50mm)
RCP5-RA8R-WA-60P-10-①-P4-②-③	10	PCON-CFA	60	40	1000	
RCP5-RA8R-WA-60P-5-①-P4-②-③	5	PCON-CFA	100	70	2000	

Code explanation ① Stroke ② Cable length ③ Options

Stroke and Maximum Speed

(unit: mm/s)

Lead (mm)	50 (mm)	100~450 (mm)	500 (mm)	550 (mm)	600 (mm)	650 (mm)	700 (mm)
20	280	400	360	320	280	240	220
10	200		180	160	140	120	110
5	100		90	80	70	60	55

① Stroke

Stroke (mm)	Standard price	Stroke (mm)	Standard price
50	Contact IAL.	400	Contact IAL.
100		450	
150		500	
200		550	
250		600	
300		650	
350		700	

② Cable Length

Type	Cable symbol	Standard price
Standard type	P(1m)	—
	S(3m)	—
	M(5m)	—
	X06(6m) ~ X10(10m)	—
Special length	X11(11m) ~ X15(15m)	—
	X16(16m) ~ X20(20m)	—
	R01(1m) ~ R03(3m)	—
Robot cable	R04(4m) ~ R05(5m)	—
	R06(6m) ~ R10(10m)	—
	R11(11m) ~ R15(15m)	—
	R16(16m) ~ R20(20m)	—

③ Option

Name	Option code	See page	Standard price
Brake	B	→P.10	Contact IAL.
Optional cable exit direction (top)	CJT		
Optional cable exit direction (outside)	CJO		
Optional cable exit direction (bottom)	CJB		
Motor side-mounted to the left (standard)	ML		
Motor side-mounted to the right	MR		
Flange bracket	FL		
Non-motor end specification	NM		

Actuator Specifications

Item	Description
Drive system	Ball screw Ø16mm, rolled C10
Positioning repeatability	±0.02mm
Lost motion	0.1mm or less
Rod	Ø40mm Aluminum
Rod non-rotation precision (*1)	±0 deg
Allowable rod load mass	Refer to P. 28 and P. 35
Rod tip overhang distance	100mm or less
Ambient operating temperature, humidity	0 to 40°C, 85% RH or less (Non-condensing)

(*1) Accuracy of rod displacement in rotating direction when no load is received.

Dimensional Drawings

CAD drawings can be downloaded from the website.

www.intelligentactuator.com

2D CAD

- *1 During home return, be careful to avoid interference from peripheral objects because the slider travels until the mechanical end.
 - *2 The orientation of the width across flats varies depending on the product.
 - *3 If the actuator is installed using the front housing and flange, make sure the actuator will not receive any external force.
(For details, refer to "Notes on Installing Rod Actuators" on P.31.)
- ME: Mechanical end
SE: Stroke end

Dimensions with Flange (Optional)

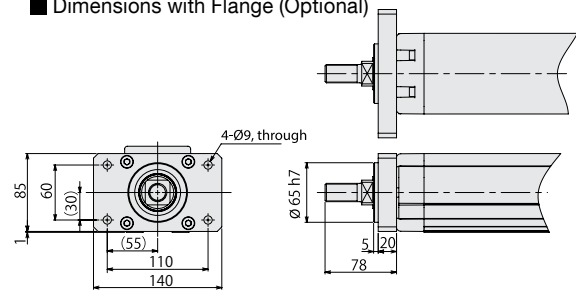

The orientation of the width across flats is indeterminate (*2).

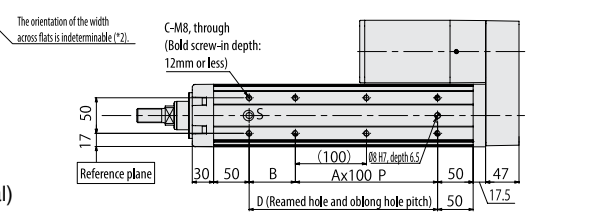
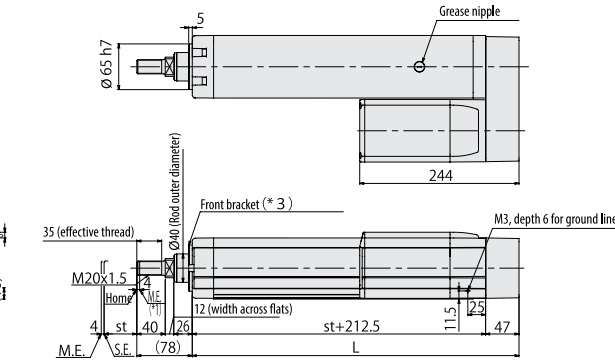
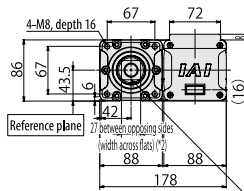
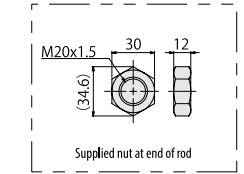

Dimensions with Brake (Optional)

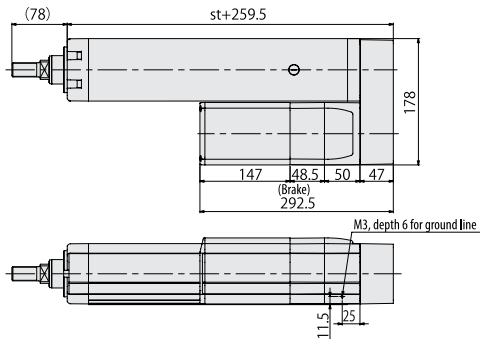

3 Cable Exit Directions (Optional)

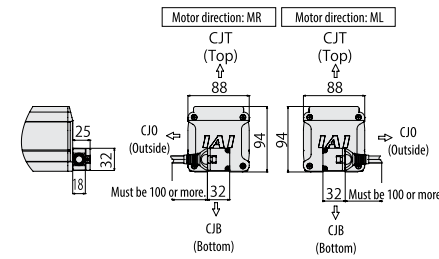

Note
If an actuator of lead 5 is installed vertically, the service life of the actuator varies significantly depending on the payload.
Pay attention to the diagram of payload and service life shown below. (If the actuator is installed horizontally, its service life is not affected by the payload.)

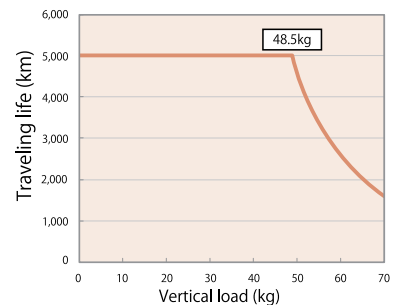

Rod Deflection of RCP5-RA8R

(The graph below shows the measurements of how much a horizontally installed rod would deflect when a load is applied to the end of the rod. The measured deflection include the deflection due to the weight of the rod.)

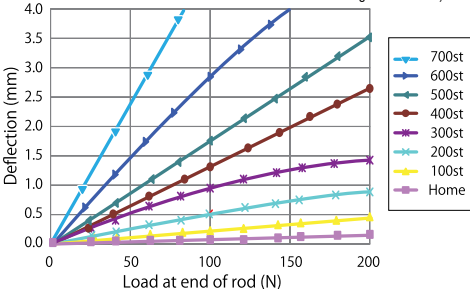

Dimensions and Mass by Stroke

Stroke	50	100	150	200	250	300	350	400	450	500	550	600	650	700
L	309.5	359.5	409.5	459.5	509.5	559.5	609.5	659.5	709.5	759.5	809.5	859.5	909.5	959.5
A	0	1	1	2	2	3	3	4	4	5	5	6	6	7
B	115	65	115	65	115	65	115	65	115	65	115	65	115	65
C	4	6	6	8	8	10	10	12	12	14	14	16	16	18
D	115	165	215	265	315	365	415	465	515	565	615	665	715	765
Allowable static load at end of rod (N)	180	150.3	128.9	112.7	99.9	89.7	81.3	74.3	68.3	63.1	58.6	54.6	51.1	47.9
Allowable dynamic load at end of rod (N)	Load offset 0mm	73.6	60.3	51.0	44.1	38.7	34.3	30.7	27.7	25.2	23.0	21.1	19.4	17.8
	Load offset 100mm	57.0	48.6	42.5	37.8	33.8	30.5	27.6	25.2	23.1	21.2	19.5	18.1	16.7
Allowable static torque at end of rod (N-m)	18.1	15.2	13.0	11.4	10.2	9.2	8.4	7.7	7.1	6.6	6.1	5.8	5.4	5.1
Allowable dynamic torque at end of rod (N-m)	Without brake	8.6	9.0	9.4	9.8	10.3	10.7	11.1	11.6	12.0	12.4	12.9	13.3	14.1
	With brake	9.6	10.0	10.4	10.9	11.3	11.7	12.2	12.6	13.0	13.4	13.9	14.3	14.7

Applicable Controller

RCP5 series actuators can be operated with the controller indicated below. Select the type according to your intended application.

Name	External view	Model number	Features	Maximum number of positioning points	Input power	Power supply capacity	Standard price	Reference page
Positioner type		PCON-CFA-60PWAJ-NP-□-□-□	Positioner type based on PIO control	512 points	DC24V	Refer to P.46	—	Refer to P.39
Pulse-train type		PCON-CFA-60PWAJ-PN-□-□-□						
Field network type		PCON-CFA-60PWAJ-PLN-□-□-□	Pulse-train input type	—				
		PCON-CFA-60PWAJ-PLP-□-□-□	Supporting major field networks	768 points				

*In the model numbers shown above, ① indicates the field network specification (DV, CC, PR, CN, ML, EC or EP).

RCP5-RA10R

ROBO Cylinder, High-thrust Rod Type, Side Mounted Motor Type, Actuator Width 108mm, 24-V Pulse Motor

Model Specification Items	RCP5 — RA10R — WA — 86P — <input type="checkbox"/> — <input type="checkbox"/> — P4 — <input type="checkbox"/> — <input type="checkbox"/>							
Series	Type	Encoder type	Motor type	Lead	Stroke	Applicable controller	Cable length	Options
		WA : Battery-less absolute specification	86P : Pulse motor, size 86 <input type="checkbox"/>	10 : 10mm 5 : 5mm 2.5 : 2.5mm	50 : 50mm 800 : 800mm (every 50mm)	P4 : PCON-CFA	N : None P : 1m S : 3m M : 5m X <input type="checkbox"/> : Specified length R <input type="checkbox"/> : Robot cable	Refer to the options table below.

Built-in guide mechanism

RoHS

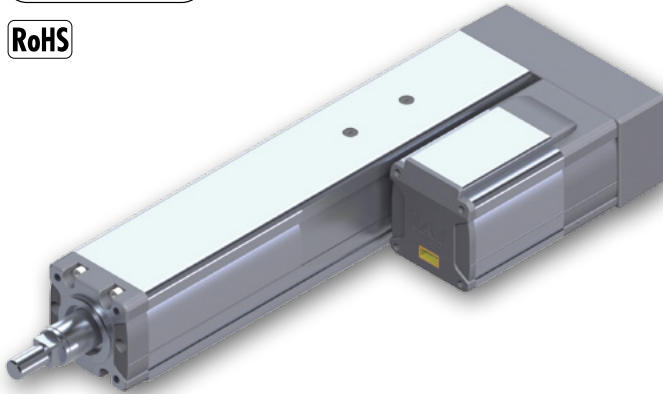

POINT
Note on selection

- (1) The payload assumes operation at an acceleration of 0.01G for lead 2.5, operation at an acceleration of 0.02G for lead 5 and operation at an acceleration of 0.04G for lead 10. The above values are the upper limits of acceleration/deceleration.
- (2) Exercise caution that the RA10R requires a dedicated controller (high-thrust PCON-CFA).

Correlation Diagrams of Speed and Payload

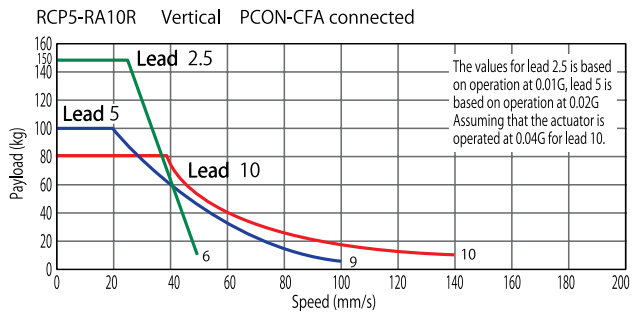
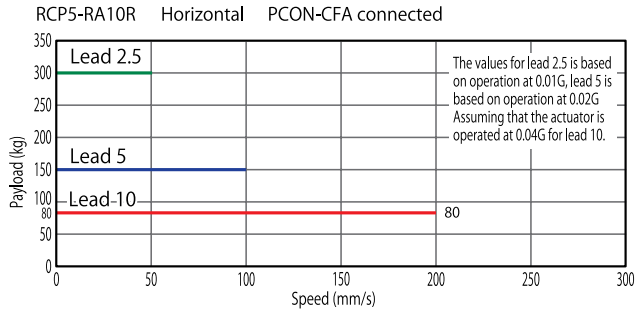

Actuator Specifications

Lead and Payload

Model number	Lead (mm)	Connected controller	Maximum payload		Maximum push force (N)	Stroke (mm)
			Horizontal (kg)	Vertical (kg)		
RCP5-RA10R-WA-86P-10-①-P4-②-③	10	PCON-CFA	80	80	1500	50~800 (every 50mm)
RCP5-RA10R-WA-86P-5-①-P4-②-③	5	PCON-CFA	150	100	3000	
RCP5-RA10R-WA-86P-2.5-①-P4-②-③	2.5	PCON-CFA	300	150	6000	

Code explanation ① Stroke ② Cable length ③ Options

Stroke and Maximum Speed

The values in <> apply when the actuator is used vertically. (unit: mm/s)

Lead (mm)	50 (mm)	100 (mm)	150 (mm)	200~400 (every 50mm)	450 (mm)	500 (mm)	550 (mm)	600 (mm)	650 (mm)	700 (mm)	750 (mm)	800 (mm)
10	117	167 <140>			200 <140>				180 <140>	160 <140>	140	120
5	83		100			90	80	70	60	55	50	45
2.5				50					45	40	35	30

① Stroke

Stroke (mm)	Standard price	Stroke (mm)	Standard price
50	Contact IAL.	450	Contact IAL.
100		500	
150		550	
200		600	
250		650	
300		700	
350		750	
400		800	

② Cable Length

Type	Cable symbol	Standard price
Standard type	P(1m)	—
	S(3m)	—
	M(5m)	—
	X06(6m) ~ X10(10m)	—
Special length	X11(11m) ~ X15(15m)	—
	X16(16m) ~ X20(20m)	—
	R01(1m) ~ R03(3m)	—
Robot cable	R04(4m) ~ R05(5m)	—
	R06(6m) ~ R10(10m)	—
	R11(11m) ~ R15(15m)	—
	R16(16m) ~ R20(20m)	—

③ Option

Name	Option code	See page	Standard price
Brake	B	→P.10	Contact IAL.
Optional cable exit direction (top)	CJT		
Optional cable exit direction (outside)	CJO		
Optional cable exit direction (bottom)	CTB		
Motor side-mounted to the left (standard)	ML		
Motor side-mounted to the right	MR		
Flange bracket	FL		
Non-motor end specification	NM		

Actuator Specifications

Item	Description
Drive system	Ball screw Ø20mm (lead 2.5/10mm), Ø16mm (lead 5mm), rolled C10
Positioning repeatability	±0.02mm
Lost motion	0.1mm or less
Rod	Ø40mm Aluminum
Rod non-rotation precision (*1)	±0 deg
Allowable rod load mass	Refer to P. 30 and P. 35
Rod tip overhang distance	100mm or less
Ambient operating temperature, humidity	0 to 40°C, 85% RH or less (Non-condensing)

(*1) Accuracy of rod displacement in rotating direction when no load is received.

Dimensional Drawings

CAD drawings can be downloaded from the website. www.intelligentactuator.com

2D CAD

- During home return, be careful to avoid interference from peripheral objects because the slider travels until the mechanical end.
- The orientation of the width across flats varies depending on the product.
- If the actuator is installed using the front housing and flange, make sure the actuator will not receive any external force. (For details, refer to "Notes on Installing Rod Actuators" on P. 31.)
ME: Mechanical end
SE: Stroke end

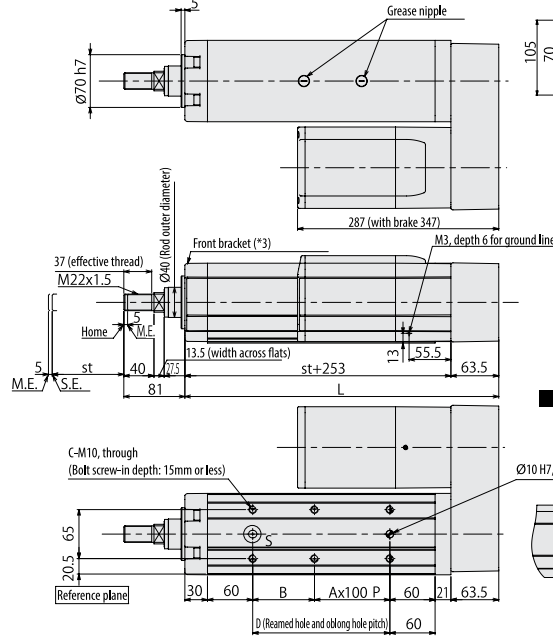
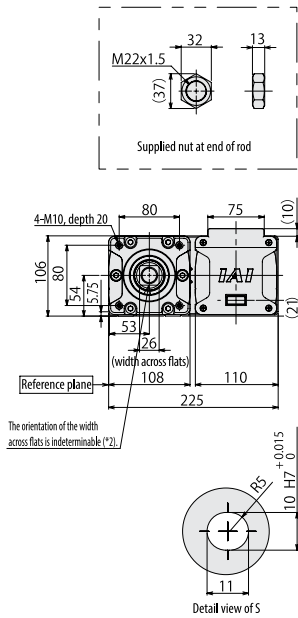

Dimensions with Flange (Optional)

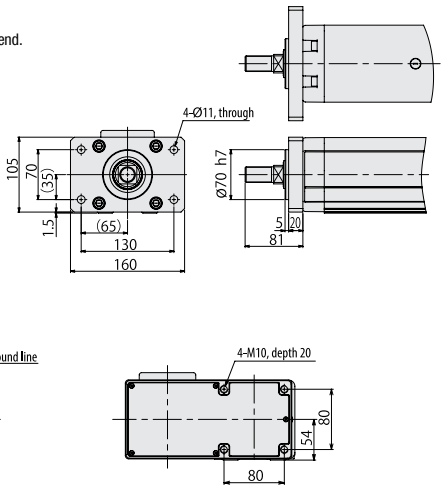

3 Cable Exit Directions (Optional)

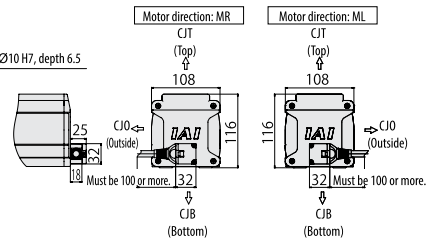

Rod Deflection of RCP5-RA10R

(The graph below shows the measurements of how much a horizontally installed rod would deflect when a load is applied to the end of the rod. The measured deflection include the deflection due to the weight of the rod.)

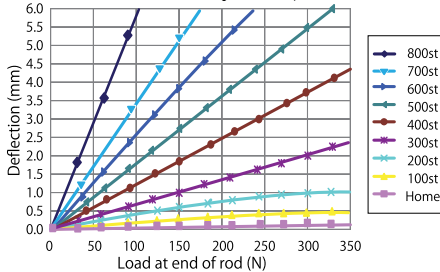

Dimensions and Mass by Stroke

Stroke	50	100	150	200	250	300	350	400	450	500	550	600	650	700	750	800
L	366.5	416.5	466.5	516.5	566.5	616.5	666.5	716.5	766.5	816.5	866.5	916.5	966.5	1016.5	1066.5	1116.5
A	0	1	1	2	2	3	3	4	4	5	5	6	6	7	7	8
B	132	82	132	82	132	82	132	82	132	82	132	82	132	82	132	82
C	4	6	6	8	8	10	10	12	12	14	14	16	16	18	18	20
D	132	182	232	282	332	382	432	482	532	582	632	682	732	782	832	882
Allowable static load at end of rod (N)	316.9	268.4	232.6	205.1	183.4	165.7	151.0	138.6	128.1	119.0	111.0	103.9	97.7	92.1	87.0	82.5
Allowable dynamic load at end of rod (N)	Load offset 0mm		119.1	99.1	84.7	73.8	65.3	58.5	52.8	48.1	44.0	40.5	37.5	34.8	32.4	30.2
	Load offset 100mm		100.7	85.9	74.9	66.3	59.3	53.6	48.8	44.7	41.2	38.1	35.4	32.9	30.8	28.8
Allowable static torque at end of rod (N-m)	Load offset 0mm		31.8	27.0	23.4	20.7	18.5	16.8	15.3	14.1	13.1	12.2	11.4	10.7	10.1	9.6
	Load offset 100mm		10.1	8.6	7.5	6.6	5.9	5.4	4.9	4.5	4.1	3.8	3.5	3.3	3.1	2.9
Mass (kg)	Without brake		14.6	15.3	16.0	16.7	17.4	18.1	18.8	19.5	20.2	20.9	21.6	22.3	23.0	23.7
	With brake		16.2	16.9	17.6	18.3	19.0	19.7	20.4	21.1	21.8	22.5	23.2	23.9	24.6	25.3

Correlation Diagrams of Vertical Load and Traveling Life

Since the RCP5-RA10R has a greater maximum thrust than other types, its service life varies significantly depending on the payload and push force applied when the actuator is installed vertically. When selecting an appropriate type from the correlation diagram of speed and payload or correlation diagram of push force and current-limiting value, check its traveling life on the correlation diagram of payload and service life as well as on the correlation diagram of push force and service life.

Note

The rated value represents the maximum value at a traveling life of 5,000km. The greatest value is the maximum value at which the actuator can operate. Take note that, if an actuator is operated beyond its rating, its service life will drop as shown by the applicable graph on the right.

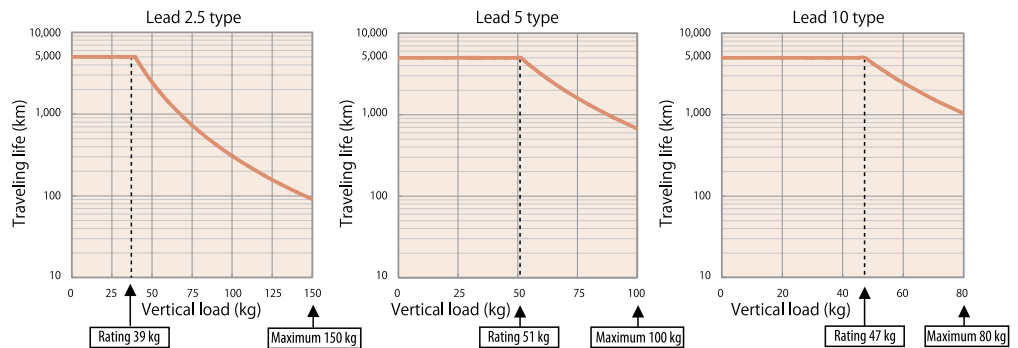

Applicable Controller

RCP5 series actuators can be operated with the controller indicated below. Select the type according to your intended application.

Name	External view	Model number	Features	Maximum number of positioning points	Input power	Power supply capacity	Standard price	Reference page
Positioner type		PCON-CFA-86PWA1-NP-□-□-□ PCON-CFA-86PWA1-PN-□-□-□	Positioner type based on PIO control	512 points	DC24V	Refer to P. 46	—	Refer to P. 39
Pulse-train type		PCON-CFA-86PWA1-PLN-□-□-□ PCON-CFA-86PWA1-PLP-□-□-□	Pulse-train input type	—				
Field network type		PCON-CFA-86PWA1-①-□-□-□	Supporting 7 major field networks	768 points				

*In the model numbers shown above, ① indicates the field network specification (DV, CC, PR, CN, ML, EC or EP).

Notes on Installing Rod Actuators

When installing the actuator using the front housing or with a flange (optional), make sure that the actuator will not receive any external forces. (External forces may cause malfunction or damaged parts.) If the actuator will receive external forces or when the actuator is combined with a Cartesian robot, etc., use the mounting holes on the actuator base to secure the actuator.

Even when the actuator does not receive any external forces, provide a support base to support the actuator, as shown in the figure on the right, if the actuator is installed horizontally and secured using a flange or through the bracket mounting holes of the side-mounted motor specification.

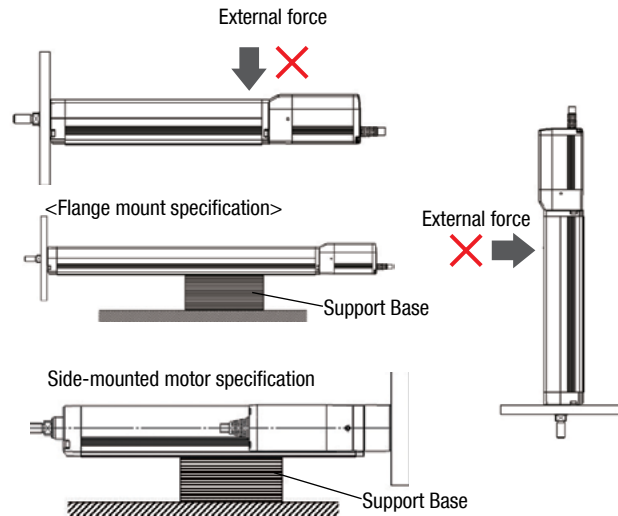

Selection Guideline (Correlation Diagram of Push Force and Current-limiting Value)

In push-motion operation, the push force can be used by changing the current-limiting value of the controller over a range of 20% to 70%. The maximum push-force varies depending on the model, so check the required push force from the graphs on the following pages and select an appropriate type meeting the purpose of use.

When performing push-motion operation using a slider actuator, limit the push current limit so that the reactive moment generated by the push force will not exceed 80% of the rated moment (M_a , M_b) specified in the catalog. To help with the moment calculations, the application position of the guide moment is shown in the figure below. Calculate the necessary moment by considering the offset of the push force application position. Note that if an excessive force exceeding the rated moment is applied, the guide may be damaged and the life may become shorter. Accordingly, include a sufficient safety factor when deciding on the push force.

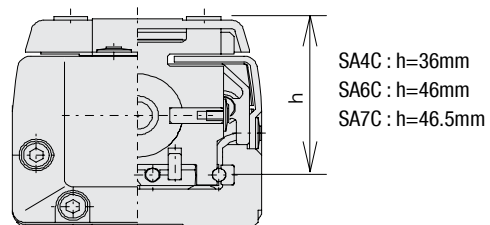

Calculation example:

If push-motion operation is performed with an RCP5-SA7C by applying 50 N at the position shown to the right, the moment received by the guide, or

$$M_a, \text{ is calculated as } (46.5 + 50) \times 50 = 4825 \text{ (N}\cdot\text{mm)} \\ = 4.825 \text{ (N}\cdot\text{m)}.$$

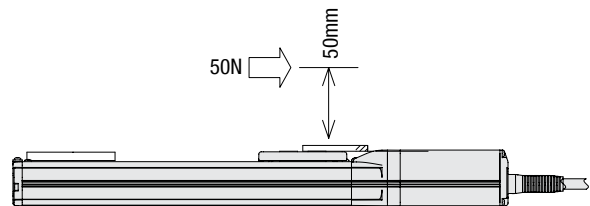

Since the rated M_a moment of the SA7C is 10 (N·m), $10 \times 0.8 = 8 > 4.825$, suggesting that this selection is acceptable.

If an M_b moment generates due to push-motion operation, calculate the moment from the overhang and confirm, in the same way, that the calculated moment is within 80% of the rated moment.

Correlation Diagrams of Push Force and Current-limiting value The graphs below are only a reference, and the graphs may vary slightly from the actual values.

SA4C/RA4C type

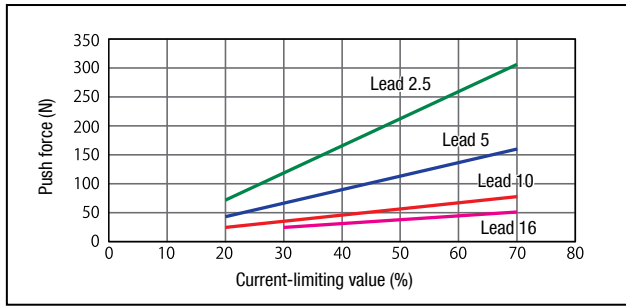

SA6C/RA6C type

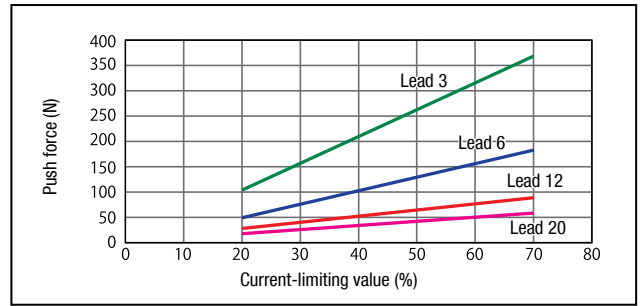

SA7C type

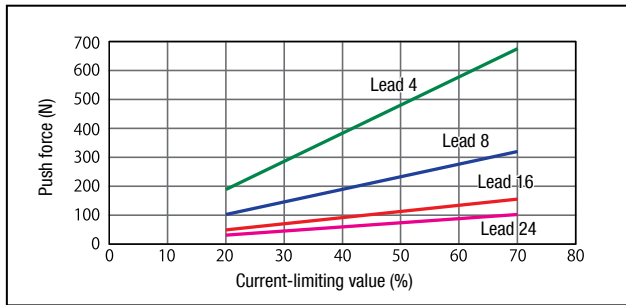

RA7C type

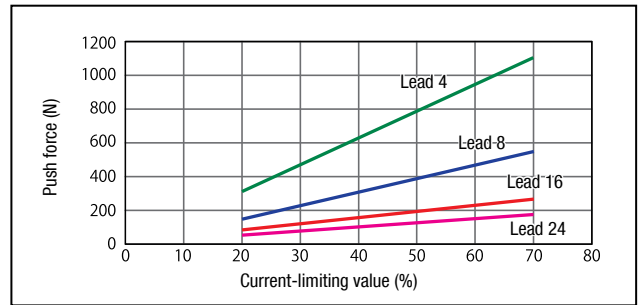

RA8C/RA8R type

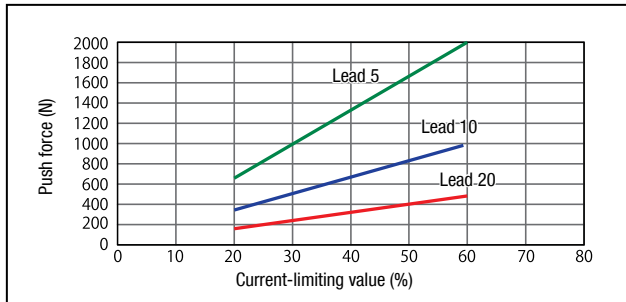

RA10C/RA10R type

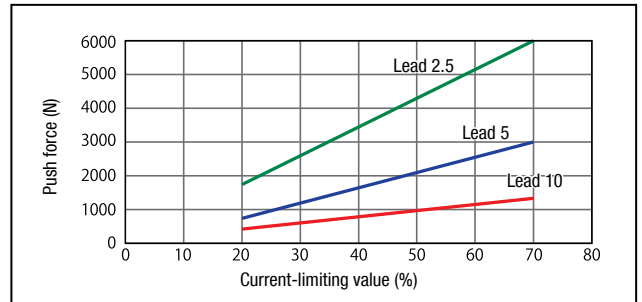

Notes on Use

- The relationship of push force and current-limiting value is only a reference, and the graphs may vary slightly from the actual values.
- If the current-limiting value is less than 20%, the push force may vary. Make sure the current-limiting value remains 20% or more.
- The graphs assume a traveling speed of 10 mm/s for RA8C/RA8R/RA10C/RA10R and 20 mm/s for other than those models during push-motion operation.
- Be sure to use the RA8C/RA8R at a current-limiting value of 60% or less, because performing push-motion operation with these actuators at a current-limiting value of 70% may lead to motor damage.
- Use the table below as a rough guide for the upper limit of push cycles when the RCP5-RA10C/RA10R of each lead is operated with the maximum push force over a push-motion travel distance of 1 mm.

Lead (type)	2.5	5	10
Push cycles	1.4 million cycles	25 million cycles	157.6 million cycles

* The upper limit of push cycles varies depending on the impact, vibration and other operating conditions. The cycles shown to the left assume no impact or vibration.

Points to Note on Push-motion Operation Using RCP5-RA10C/RA10R

The push force is limited on certain RA10C/RA10R models due to its relationship with the buckling load of the ball screw. (Refer to the table below.)

Items	Stroke 550 mm or less	Stroke 600 mm or less	Stroke 650 mm or less	Stroke 700 mm or less	Stroke 750 mm or less	Stroke 800 mm or less
Lead 10	As shown in the push force graph					
Lead 5	As shown in the graph	2900	2500	2200	2000	1800
Lead 2.5	As shown in the graph				5900	5400

Selection Guideline (Tables of RCP5 Payload by Speed/Acceleration)

When operating the RCP5, increasing the speed/acceleration reduces the travel time, but it also causes the payload to drop. The tables below provide correlations between speed/acceleration and payload for different models, so check the applicable graph to see if the model you will be using meets the conditions you desire. Also note that the maximum speed, maximum acceleration and payload vary between the Power CON (high output setting) specification and the standard specification. Check your specification in each table (the upper tables represent the Power CON specification, while the lower tables represent the standard specification).

RCP5-SA4C

Power CON Specification		Lead 16							
Orientation	Speed (mm/s)	Horizontal			Vertical				
		Acceleration (G)							
		0.1	0.3	0.5	0.7	1	0.1	0.3	0.5
0	4	4	4	4	4	4	1	1	1
140	4	4	4	4	4	4	1	1	1
280	4	4	4	4	4	4	1	1	1
420	4	4	4	4	4	4	1	1	1
560	4	4	4	4	4	4	1	1	1
700	4	4	4	4	4	4	1	1	1
840	4	4	4	4	3.5		1	1	1
980	4	4	3.5	3			1	1	1
1120	4	3	2	1.5			1	0.75	
1260			2	1.5	1				0.5

Power CON Specification		Lead 10							
Orientation	Speed (mm/s)	Horizontal			Vertical				
		Acceleration (G)							
		0.1	0.3	0.5	0.7	1	0.1	0.3	0.5
0	10	10	10	8	8	8	2.25	2.25	2.25
85	10	10	10	8	8	8	2.25	2.25	2.25
175	10	10	10	8	8	8	2.25	2.25	2.25
260	9	9	9	8	8	8	2.25	2.25	2.25
350	9	9	9	8	8	8	2.25	2.25	2.25
435	8	8	8	8	8	8	2.25	2.25	2.25
525	8	8	8	7	7	7	2.25	2.25	2.25
610	8	8	7	6	5	5	2.25	2.25	2.25
700	8	6	4	3			2	2	2
785	7	4	3	3			2	1.5	

Power CON Specification		Lead 5							
Orientation	Speed (mm/s)	Horizontal			Vertical				
		Acceleration (G)							
		0.1	0.3	0.5	0.7	1	0.1	0.3	0.5
0	12	12	12	10	10	10	4.5	4.5	4.5
40	12	12	12	10	10	10	4.5	4.5	4.5
85	12	12	12	10	10	10	4.5	4.5	4.5
130	11	11	11	10	10	10	4.5	4.5	4.5
175	10	10	10	10	10	10	4.5	4.5	4.5
215	10	10	10	10	10	10	4.5	4.5	4.5
260	10	10	10	10	10	10	4.5	4.5	4.5
305	10	10	10	10	10	10	4.5	4.5	4.5
350	10	10	10	10	10	10	4.5	4.5	4.5
390	10	10	10	10	10	10	4.5	4.5	4.5

Power CON Specification		Lead 2.5							
Orientation	Speed (mm/s)	Horizontal			Vertical				
		Acceleration (G)							
		0.1	0.3	0.5	0.7	1	0.1	0.3	0.5
0	12	12	12	12	12	12	9	9	9
20	12	12	12	12	12	12	9	9	9
40	12	12	12	12	12	12	9	9	9
65	12	12	12	12	12	12	9	9	9
85	12	12	12	12	12	12	9	9	9
105	12	12	12	12	12	12	9	9	9
130	12	12	12	12	12	12	9	9	9
150	12	12	12	12	12	12	9	9	9
175	12	12	12	12	12	12	9	9	9
195	12	12	12	12	12	12	9	9	9

Standard Specification		Lead 16							
Orientation	Speed (mm/s)	Horizontal			Vertical				
		Acceleration (G)							
		0.1	0.3	0.5	0.7	1	0.1	0.2	0.5
0	4	4	4	3.5	1	1	1	1	1
140	4	4	4	3.5	1	1	1	1	1
280	4	4	4	3.5	1	1	1	1	1
420	4	4	3.5	3	1	1	0.75		
560	4	3.5	3	2.5	1	0.75	0.75		
700	3.5	3	2.5	2	0.75	0.75	0.5		
840		2.5	2	1.5		0.5	0.5		

Standard Specification		Lead 10							
Orientation	Speed (mm/s)	Horizontal			Vertical				
		Acceleration (G)							
		0.2	0.3	0.5	0.7	1	0.2	0.3	
0	10	10	9	8	2.25	2.25	2.25		
85	10	10	9	8	2.25	2.25	2.25		
175	10	10	9	8	2.25	2.25	2.25		
260	9	9	8	6	2	2	2		
350	8	7	6	5	2	2	2		
435	7	6	5	4	2	1.5	1.5		
525	6	5	4	3	1.5	1	1		

Standard Specification		Lead 5							
Orientation	Speed (mm/s)	Horizontal			Vertical				
		Acceleration (G)							
		0.2	0.3	0.5	0.7	1	0.2	0.3	
0	12	12	12	10	4.5	4.5	4.5		
40	12	12	12	10	4.5	4.5	4.5		
85	12	12	12	10	4.5	4.5	4.5		
130	10	10	10	9	4	4	4		
175	10	10	9	8	4	4	4		
215	10	9	8	7	4	4	4		
260	9	8	7	6	3.5	3	2.5		

Standard Specification		Lead 2.5							
Orientation	Speed (mm/s)	Horizontal			Vertical				
		Acceleration (G)							
		0.2	0.3	0.5	0.7	1	0.2	0.3	
0	12	12	12	12	9	9	9		
20	12	12	12	12	9	9	9		
40	12	12	12	12	9	9	9		
65	12	12	11	11	8	8	8		
85	12	11	10	10	8	8	8		
105	12	10	10	9	8	8	8		
130	12	10	9	8	5	5	5		

RCP5-SA6C

Power CON Specification		Lead 20							
Orientation	Speed (mm/s)	Horizontal			Vertical				
		Acceleration (G)							
		0.1	0.3	0.5	0.7	1	0.1	0.3	0.5
0	10	10	9	7	6	1	1	1	1
160	10	10	9	7	6	1	1	1	1
320	10	10	9	7	6	1	1	1	1
480	10	10	9	7	6	1	1	1	1
640	10	10	8	6	5	1	1	1	1
800	10	9	6.5	4.5	3	1	1	1	1
960		8	5	3.5	2		1	1	1
1120		6.5	3	2	1.5		0.5	0.5	
1280			1	1	1				0.5
1440			1	0.5					

Power CON Specification		Lead 12							
Orientation	Speed (mm/s)	Horizontal			Vertical				
		Acceleration (G)							
		0.1	0.3	0.5	0.7	1	0.1	0.3	0.5
0	15	15	12.5	11	10	2.5	2.5	2.5	
100	15	15	12.5	11	10	2.5	2.5	2.5	
200	15	15	12.5	11	10	2.5	2.5	2.5	
300	15	15	12.5	11	10	2.5	2.5	2.5	
400	15	14	11	10	8.5	2.5	2.5	2.5	
500	15	13	10	8	6.5	2.5	2.5	2.5	
600	15	12	9	6	4	2.5	2.5	2.5	
700	12	10	8	4	2.5	2.5	2.5		
800	10	7	5	2	1	2	1.5	1	
900		5	3	1	1		0.5	0.5	

Power CON Specification		Lead 6							
Orientation	Speed (mm/s)	Horizontal			Vertical				
		Acceleration (G)							
		0.1	0.3	0.5	0.7	1	0.1	0.3	0.5
0	25	25	20	16	14	6	6	6	6
50	25	25	20	16	14	6	6	6	6
100	25	25	20	16	14	6	6	6	6
150	25	25	20	16	14	6	6	6	6
200	25	25	20	16	14	6	6	6	6
250	25	25	20	16	14	6	6	5.5	
300	25	25	20	15	11	6	5.5	5	
350	25	20	14	12	9	6	4.5	4	
400	25	16	10	8	6.5	4.5	3.5	3	
450	18	12	6	5	2.5	3.5	2	2	

Power CON Specification		Lead 3							
Orientation	Speed (mm/s)	Horizontal			Vertical				
		Acceleration (G)							
		0.1	0.3	0.5	0.7	1	0.1	0.3	0.5
0	25	25	25	25	25	16	16	16	16
20	25	25	25	25	25	16	16	16	16
40	25	25	25	25	25	16	16	16	16
65	25	25	25	25	25	16	16	16	16
85	25	25	25	25	25	16	16	16	16
105	25	25	25	25	25	16	16	16	16
130	25	25	25	25	22.5	16	14	13	
150	25	25	25	20	19	13	12	11	
175	25	25	20	18	16	11	10	9	
195	25	18	16	15	12	9	8		

Standard Specification		Lead 20						
Orientation	Speed (mm/s)	Horizontal			Vertical			
		Acceleration (G)						
		0.2	0.3	0.5	0.7	1	0.1	0.2
0	6	6	4	4	0.5	0.5		
160	6	6	4	4	0.5	0.5		
320	6	6	4	4	0.5	0.5		
480	5	5	3	3	0.5	0.5		
640	4	4	2	2	0.5	0.5		
800	3	3	1	1	0.5	0.5		
960	2	2	1	0.5		0.5		

Standard Specification		Lead 12							
Orientation	Speed (mm/s)	Horizontal			Vertical				
		Acceleration (G)							
		0.2	0.3	0.5	0.7	1	0.1	0.2	0.3
0	10	8.5	7	6	2	2	2		
100	10	8.5	7	6	2	2	2		
200	10	8.5	7	6	2	2	2		
300	9	8.5	7	6	2	2	2		
400	8	7	4	3.5	2	2	1.5		
500	7	6	3	2	1.5	1.5	1		
600	6	6	2	1.5	1	1	0.5		

Standard Specification		Lead 6					
Orientation	Speed (mm/s)	Horizontal			Vertical		
		Acceleration (

RCP5-RA4C

Power CON Specification Lead 16

Orientation	Horizontal					Vertical		
	Acceleration (G)							
Speed (mm/s)	0.1	0.3	0.5	0.7	1	0.1	0.3	0.5
0	6	6	6	5	3.5	1.5	1.5	1.5
140	6	6	6	5	3.5	1.5	1	1.5
280	6	6	6	5	3.5	1.5	1	1.5
420	6	6	6	5	3.5	1	1	1
560	6	6	5	3.5	1	1	1	
700	5.5	5	4	2.5	1	1	1	
840	4.5	3.5	3	2	1	1	1	
980	2.5	2	1.5	1	1	1	1	
1120		2	1.5	1			0.75	

Standard Specification Lead 16

Orientation	Horizontal					Vertical		
	Acceleration (G)							
Speed (mm/s)	0.1	0.3	0.5	0.7	1	0.1	0.3	0.5
0	6	6	6	5	3.5	1.5	1.5	1.5
140	6	6	6	5	3.5	1.5	1.5	1.5
280	6	6	6	5	3.5	1.5	1.5	1.5
420	6	6	6	5	3.5	1	1	1
560	6	5.5	4.5	3.5	1	1	1	
700	5	4	3.5	2	1	1	1	
840	4	2.5	1.5	1			0.75	

Power CON Specification Lead 10

Orientation	Horizontal					Vertical		
	Acceleration (G)							
Speed (mm/s)	0.1	0.3	0.5	0.7	1	0.1	0.3	0.5
0	15	15	13	13	12	2.5	2.5	2.5
85	15	15	13	13	12	2.5	2.5	2.5
175	15	15	13	13	12	2.5	2.5	2.5
260	15	15	13	13	12	2.5	2.5	2.5
350	15	15	13	13	10	2.5	2.5	2.5
435	15	15	13	11	9	2.5	2.5	2.5
525	14	14	10	8	7	2.5	2.5	2.5
610	9	7	5	4	2.25	2.5	2.5	
700	6	5	3	2	2	2	2	

Standard Specification Lead 10

Orientation	Horizontal					Vertical		
	Acceleration (G)							
Speed (mm/s)	0.1	0.3	0.5	0.7	1	0.1	0.3	0.5
0	15	15	13	12	12	2.5	2.5	2.5
85	15	15	13	12	12	2.5	2.5	2.5
175	15	15	13	12	12	2.5	2.5	2.5
260	12	15	13	12	12	2.5	2.5	2.5
350	12	15	13	12	10	2.5	2.5	2.5
435	12	12	12	7	7	2.25	2.25	2.25
525	11	8	8	4	4	2	2	2
610	6	4	3	2	1	1	1	
700	3	2.5	1.5	1	0.5	0.5	0.5	

Power CON Specification Lead 5

Orientation	Horizontal					Vertical		
	Acceleration (G)							
Speed (mm/s)	0.1	0.3	0.5	0.7	1	0.1	0.3	0.5
0	28	25	22	20	20	5	5	5
40	28	25	22	20	20	5	5	5
85	28	25	22	20	20	5	5	5
130	28	25	22	20	20	5	5	5
175	28	25	22	20	20	5	5	5
215	28	25	22	20	20	5	5	5
260	28	25	22	20	18	5	5	5
305	28	22	20	18	16	5	5	4.5
350	28	20	16	14	12	5	4	3.5

Standard Specification Lead 5

Orientation	Horizontal					Vertical		
	Acceleration (G)							
Speed (mm/s)	0.1	0.3	0.5	0.7	1	0.1	0.3	0.5
0	28	25	22	20	20	5	5	5
40	28	25	22	20	20	5	5	5
85	28	25	22	20	20	5	5	5
130	28	25	22	20	20	5	5	5
175	28	25	22	20	20	5	5	5
215	28	25	22	20	20	5	5	5
260	28	20	17	16	15	4.5	4.5	4
305	28	16	12	10	8.5	3	3	
350	17	11	7	6	4	2	2	2

Power CON Specification Lead 2.5

Orientation	Horizontal					Vertical		
	Acceleration (G)							
Speed (mm/s)	0.1	0.3	0.5	0.7	1	0.1	0.3	0.5
0	40	40	40	35	30	10	10	10
20	40	40	40	35	30	10	10	10
40	40	40	40	35	30	10	10	10
65	40	40	40	35	30	10	10	10
85	40	40	40	35	30	10	10	10
105	40	40	35	30	10	10	10	
130	40	40	35	30	10	10	9	
150	40	35	30	30	10	10	8	
175	40	35	30	25	9	8	7	

Standard Specification Lead 2.5

Orientation	Horizontal					Vertical		
	Acceleration (G)							
Speed (mm/s)	0.1	0.3	0.5	0.7	1	0.1	0.3	0.5
0	36	36	36	32	30	10	10	10
20	36	36	36	32	30	10	10	10
40	36	36	36	32	30	10	10	10
65	36	36	36	32	30	10	10	10
85	36	36	36	32	30	10	10	10
105	36	36	32	30	10	10	10	
130	36	32	32	30	9	9	8	
150	32	32	28	24	20	5	5	
175	28	18	16	12	2	2	2	

RCP5-RA6C

Power CON Specification Lead 20

Orientation	Horizontal					Vertical		
	Acceleration (G)							
Speed (mm/s)	0.1	0.3	0.5	0.7	1	0.1	0.3	0.5
0	6	6	6	5	5	1.5	1.5	1.5
160	6	6	6	5	5	1.5	1.5	1.5
320	6	6	6	5	3	1.5	1.5	1.5
480	6	6	6	5	3	1.5	1.5	1.5
640	6	4	3	2	1.5	1.5	1.5	
800	4	3			1	1	1	

Standard Specification Lead 20

Orientation	Horizontal					Vertical		
	Acceleration (G)							
Speed (mm/s)	0.2	0.3	0.5	0.7	1	0.1	0.2	0.3
0	6					1.5		
160	6					1.5		
320	6					1.5		
480	4					1		
640	3					0.5		

Power CON Specification Lead 12

Orientation	Horizontal					Vertical		
	Acceleration (G)							
Speed (mm/s)	0.1	0.3	0.5	0.7	1	0.1	0.3	0.5
0	25	25	18	16	12	4	4	4
100	25	25	18	16	12	4	4	4
200	25	25	18	16	10	4	4	4
300	25	25	18	12	8	4	4	4
400	20	20	14	10	6	4	4	4
500	15	15	8	6	4	4	3.5	3
600	10	10	6	3	2	4	3	2
700	6	2				2	1	

Standard Specification Lead 12

Orientation	Horizontal					Vertical		
	Acceleration (G)							
Speed (mm/s)	0.2	0.3	0.5	0.7	1	0.1	0.2	0.3
0	25					4		
100	25					4		
200	25					4		
300	20					3		
400	10					2		
500	5					1		

Power CON Specification Lead 6

Orientation	Horizontal					Vertical		
	Acceleration (G)							
Speed (mm/s)	0.1	0.3	0.5	0.7	1	0.1	0.3	0.5
0	40	40	35	30	25	10	10	10
50	40	40	35	30	25	10	10	10
100	40	40	35	30	25	10	10	10
150	40	40	35	25	25	10	10	10
200	40	40	30	25	20	10	10	10
250	40	40	27.5	22.5	18	10	9	8
300	40	35	25	20	14	6	6	6
350	40	30	14	12	10	5	5	5
400	30	18	10	6	5	4	3	3
450	25	8	3			2	2	1

Standard Specification Lead 6

Orientation	Horizontal					Vertical		
	Acceleration (G)							
Speed (mm/s)	0.2	0.3	0.5	0.7	1	0.1	0.2	0.3
0	40					10		
50	40					10		
100	40					10		
150	40					8		
200	35					5		
250	10					3		

Power CON Specification Lead 3

Orientation	Horizontal					Vertical		
	Acceleration (G)							
Speed (mm/s)	0.1	0.3	0.5	0.7	1	0.1	0.3	0.5
0	60	60	50	45	40	20	20	20
25	60	60	50	45	40	20	20	20
50	60	60	50	45	40	20	20	20
75	60	60	50	45	40	20	20	20
100	60	60	50	45	40	20	20	20
125	60	60	50	40	38	18	14	10
150	60	50	40	30	25	14	10	
175	60	40	35	25	20	12	6	5
200	60	35	30	20	14	8	5.5	
225	40	16	16	10	6	5	4	

Standard Specification Lead 3

Orientation	Horizontal					Vertical		
	Acceleration (G)							
Speed (mm/s)	0.2	0.3	0.5	0.7	1	0.1	0.2	0.3
0	40					20		
25	40					20		
50	40					16		
75	40					12		
100	40							

RCP5-RA10C

Lead 2.5

Orientation	Horizontal	Orientation	Vertical
Speed	Acceleration (G)	Speed	Acceleration (G)
(mm/s)	0.01G	(mm/s)	0.01G
0	300	0	150
42	300	20	150
63	300	30	100
		35	75
		37	65
		50	30
		55	20
		63	10

Lead 5

Orientation	Horizontal	Orientation	Vertical
Speed	Acceleration (G)	Speed	Acceleration (G)
(mm/s)	0.02G	(mm/s)	0.02G
0	150	0	100
63	150	20	100
125	150	26	90
		40	65
		45	55
		55	40
		58	37
		60	35
		65	29
		68	27
		70	25
		77	20
		90	13
		100	9
		105	7
		125	3

Lead 10

Orientation	Horizontal	Orientation	Vertical
Speed	Acceleration (G)	Speed	Acceleration (G)
(mm/s)	0.04G	(mm/s)	0.04G
0	80	0	80
100	80	34	80
175	80	37	69
200	80	45	58
225	38	53	50
240	20	75	35
250	15	105	20
		120	15
		140	10
		152	8
		167	6

RCP5-RA10R

Lead 2.5

Orientation	Horizontal	Orientation	Vertical
Speed	Acceleration (G)	Speed	Acceleration (G)
(mm/s)	0.01G	(mm/s)	0.01G
0	300	0	150
50	300	20	150
		30	95
		35	70
		37	60
		50	6

Lead 5

Orientation	Horizontal	Orientation	Vertical
Speed	Acceleration (G)	Speed	Acceleration (G)
(mm/s)	0.02G	(mm/s)	0.02G
0	150	0	100
100	150	20	100
		26	90
		40	65
		45	55
		55	40
		58	37
		60	35
		65	29
		68	27
		70	25
		77	20
		90	13
		100	9

Lead 10

Orientation	Horizontal	Orientation	Vertical
Speed	Acceleration (G)	Speed	Acceleration (G)
(mm/s)	0.04G	(mm/s)	0.04G
0	80	0	80
200	80	34	80
		37	69
		45	58
		53	50
		75	35
		105	20
		120	15
		140	10

Selection References (Guide for Selecting Allowable Load for Radial Cylinder)

The radial cylinder has a built-in guide, so loads up to a certain level can be applied to the rod without using an external guide. Refer to the graphs below for the allowable load mass. If the allowable load will be exceeded under the required operating conditions, add an external guide.

Allowable load mass for RCP5, horizontally mounted

【Horizontally mounted, laid flat】

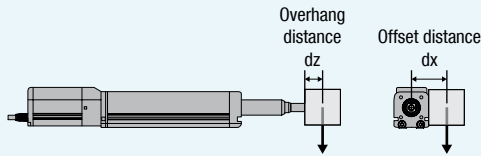

【Horizontally mounted, laid on its side】

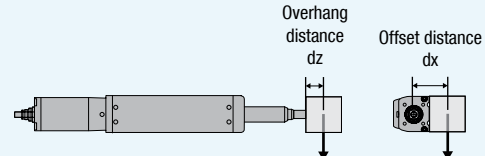

RCP5-RA4/RA6/RA7

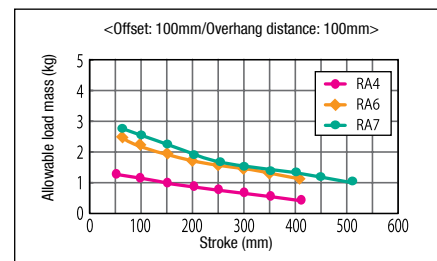
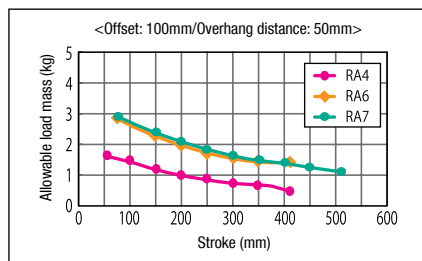
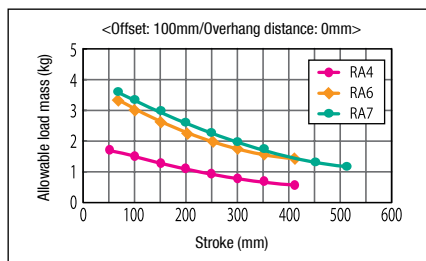
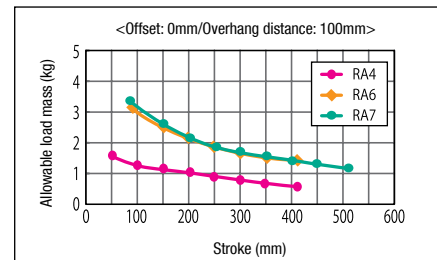
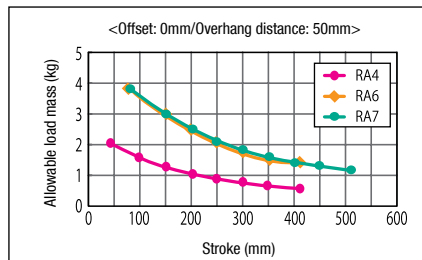
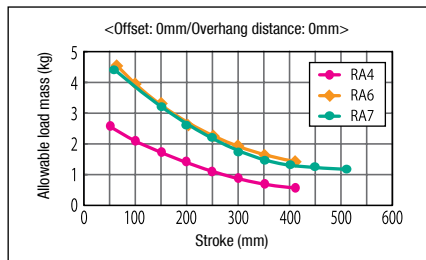

RCP5-RA8/RA10

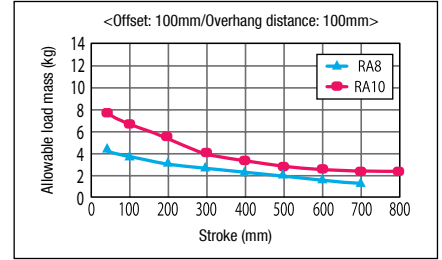
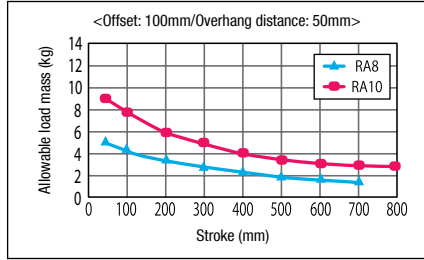
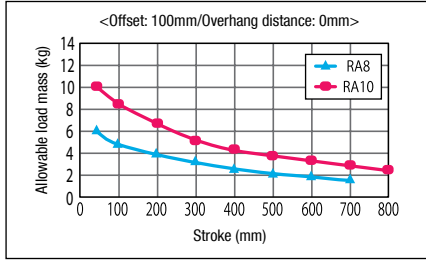
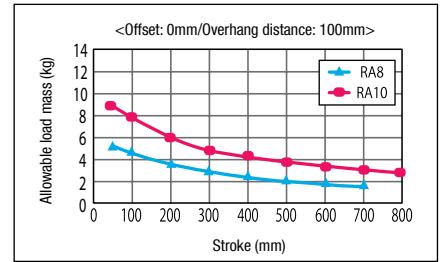
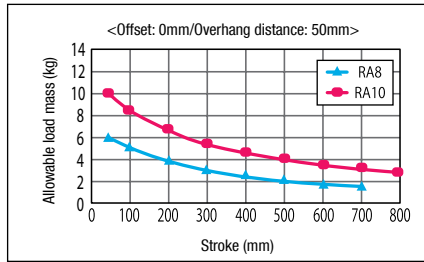
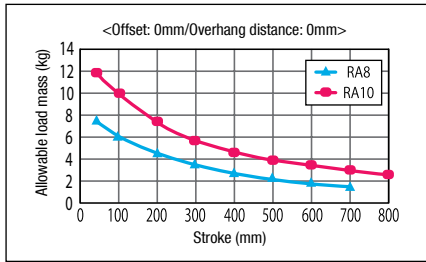

Allowable load mass for RCP5, vertically mounted

[Vertically mounted]

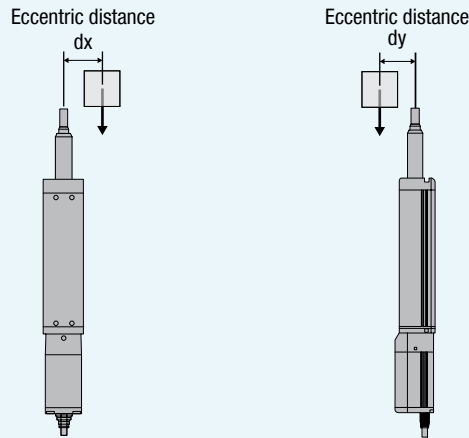

Allowable load calculation conditions.
Load mass corresponding to a product traveling life of 5,000 km, considering moments generated by acceleration/deceleration.
(Maximum speed in the specification of speed.)

RCP5-RA4

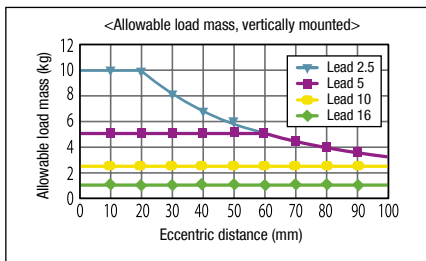

RCP5-RA6

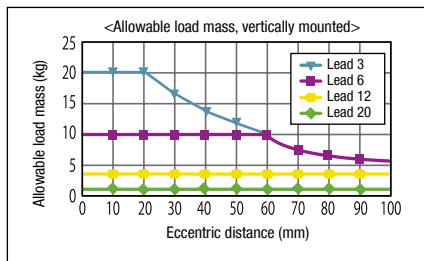

RCP5-RA7

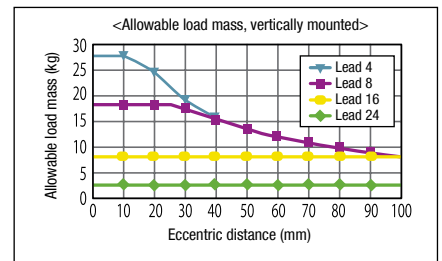

RCP5-RA8

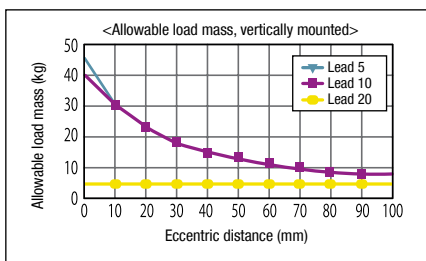

RCP5-RA10

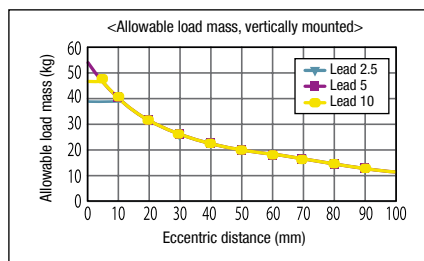

System Configuration

Single-axis Specification

→ Refer to P. 39

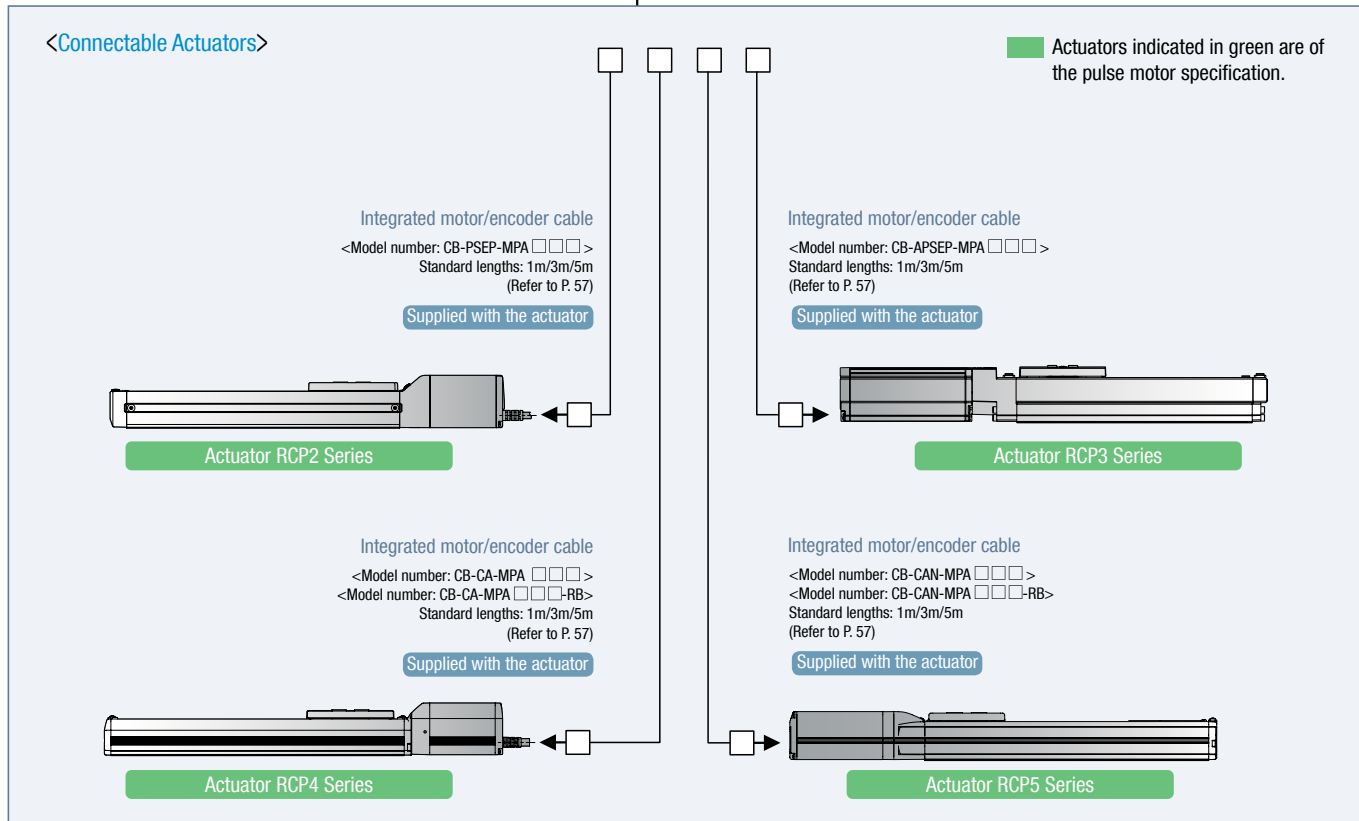
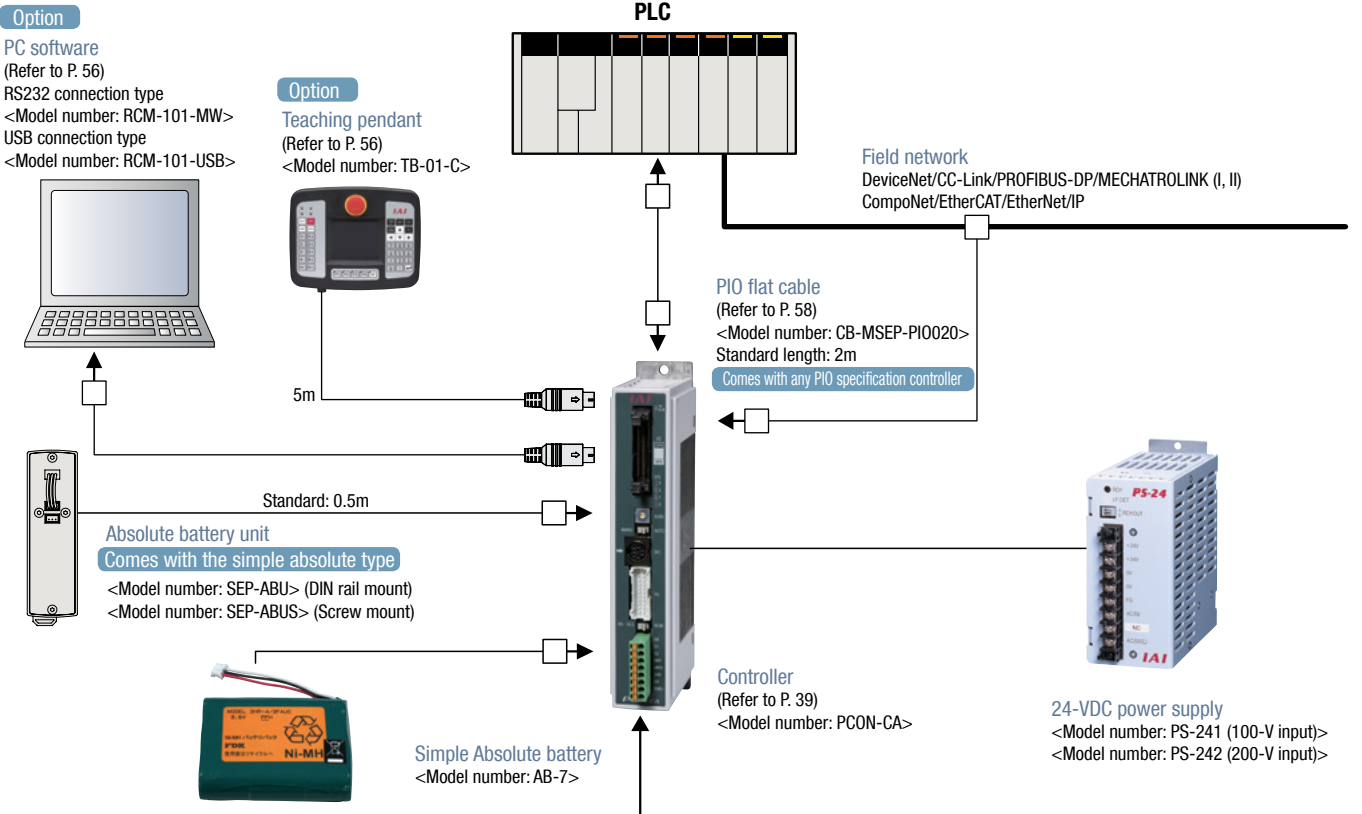

Multi-axis Specification (8-axis Specification/6-axis Specification with I/O Control Function)

→ Refer to P. 47

Option

PC software
(Refer to P. 56)
RS232 connection type
<Model number: RCM-101-MW>
USB connection type
<Model number: RCM-101-USB>

*The Power CON (high-output driver) and Mini Cylinder are supported by Ver. 9.06.00.00 or later.

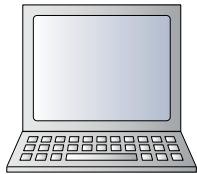

This cable comes with the PC software.

This cable comes with the absolute battery box.

Option

Absolute battery box
<Model number: MSEP-ABB>
Replacement battery
<Model number: AB-7>

Option

Teaching pendant
(Refer to P. 56)
<Model number: TB-01-C>



5m

5m

*If "Simple absolute type" is specified for the controller model, the controller will come with the absolute battery box. (Refer to P. 56 for the dimensions.)

PLC



Field network
DeviceNet/CC-Link/PROFIBUS-DP/
CompoNet/EtherCAT/EtherNet/IP

PIO flat cable
(Refer to P. 58)
<Model number: CB-MSEP-PIO020>
Standard length: 2m
Comes with any PIO specification controller.

* You can choose either the PIO specification or field network specification for your controller.

* To connect to a field network, you must set up the controller communications using the gateway parameter setting tool that comes with the PC software. Please purchase the PC software if you don't already have it.

* Field network connection cables are the responsibility of the customer.

Controller

(Refer to P. 47)
<Model number: MSEP-C>
<Model number: MSEP-LC>



24-VDC power supply **Option**
<Model number: PS-241 (100-V input)>
<Model number: PS-242 (200-V input)>

<Connectable Actuators>

Integrated motor/encoder cable
<Model number: CB-PSEP-MPA □□□>
Standard lengths: 1m/3m/5m
(Refer to P. 57)
Supplied with the actuator



Actuator RCP2 Series

*The RCP2-RTBS/RTCS are excluded.

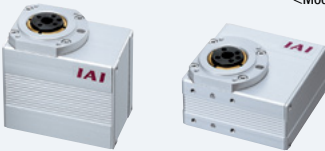

Actuator RCP2, Small Rotary (RCP2-RTBS/RTCS)

Integrated motor/encoder cable
<Model number: CB-RPSEP-MPA □□□>
Standard lengths: 1m/3m/5m
(Refer to P. 58)
Supplied with the actuator

*Exercise caution that rotary actuators of the 360-degree specification (RCP2-RT□SL/RT□L/RT□BL) are not supported.

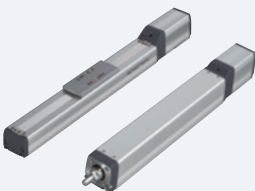

Actuator RCP4 Series

Integrated motor/encoder cable
<Model number: CB-CA-MPA □□□>
Integrated robot motor/encoder cable
<Model number: CB-CA-MPA □□□-RB>
Standard lengths: 1m/3m/5m
(Refer to P. 57)
Supplied with the actuator

Actuators indicated in green are of the pulse motor specification.
Actuators indicated in blue are of the servo motor specification.
Actuators indicated in orange are of the DC servo motor specification.

Integrated motor/encoder cable
<Model number: CB-APSEP-MPA □□□>
Standard lengths: 1m/3m/5m
(Refer to P. 57)
Supplied with the actuator



Actuator RCA series

Integrated motor/encoder cable
<Model number: CB-APSEP-MPA □□□>
Standard lengths: 1m/3m/5m
(Refer to P. 57)
Supplied with the actuator

Actuator **RCP3 Series** **RCP2-GRSS/GRLS/GRST**
RCP2-SRA4R/SRGS4R/SRGD4R
RCA2 Series **RCL Series** (Note 1)

(Note 1) Exercise caution that the RCL series does not support the simple absolute specification.

Integrated motor/encoder cable
<Model number: CB-CAN-MPA □□□>
Integrated robot motor/encoder cable
<Model number: CB-CAN-MPA □□□-RB>
Standard lengths: 1m/3m/5m
(Refer to P. 57)
Supplied with the actuator



Actuator RCP5 Series RCD Series

List of Models

ROBO Cylinder Position Controller PCON-CA/CFA

I/O type	Positioner type	Pulse-train type	Field network type							
			DeviceNet connection specification	CC-Link connection specification	PROFIBUS-DP connection specification	CompoNet connection specification	MECHATROLINK connection specification	EtherCAT connection specification	EtherNet/IP connection specification	PROFINET IO connection specification
I/O type model number	NP/PN	PLN/PLP	DV	CC	PR	CN	ML	EC	EP	PRT
PCON-CA	Battery-less absolute specification	—	—	—	—	—	—	—	—	—
	Simple absolute specification	with absolute battery	—	—	—	—	—	—	—	—
		with absolute battery unit	—	—	—	—	—	—	—	—
		No absolute battery	—	—	—	—	—	—	—	—
PCON-CFA	Battery-less absolute specification	—	—	—	—	—	—	—	—	

* If the RCP5 is used with pulse-train I/Os, the actuator must complete a home return prior to operation, as with any incremental actuator.

Model Specification Items

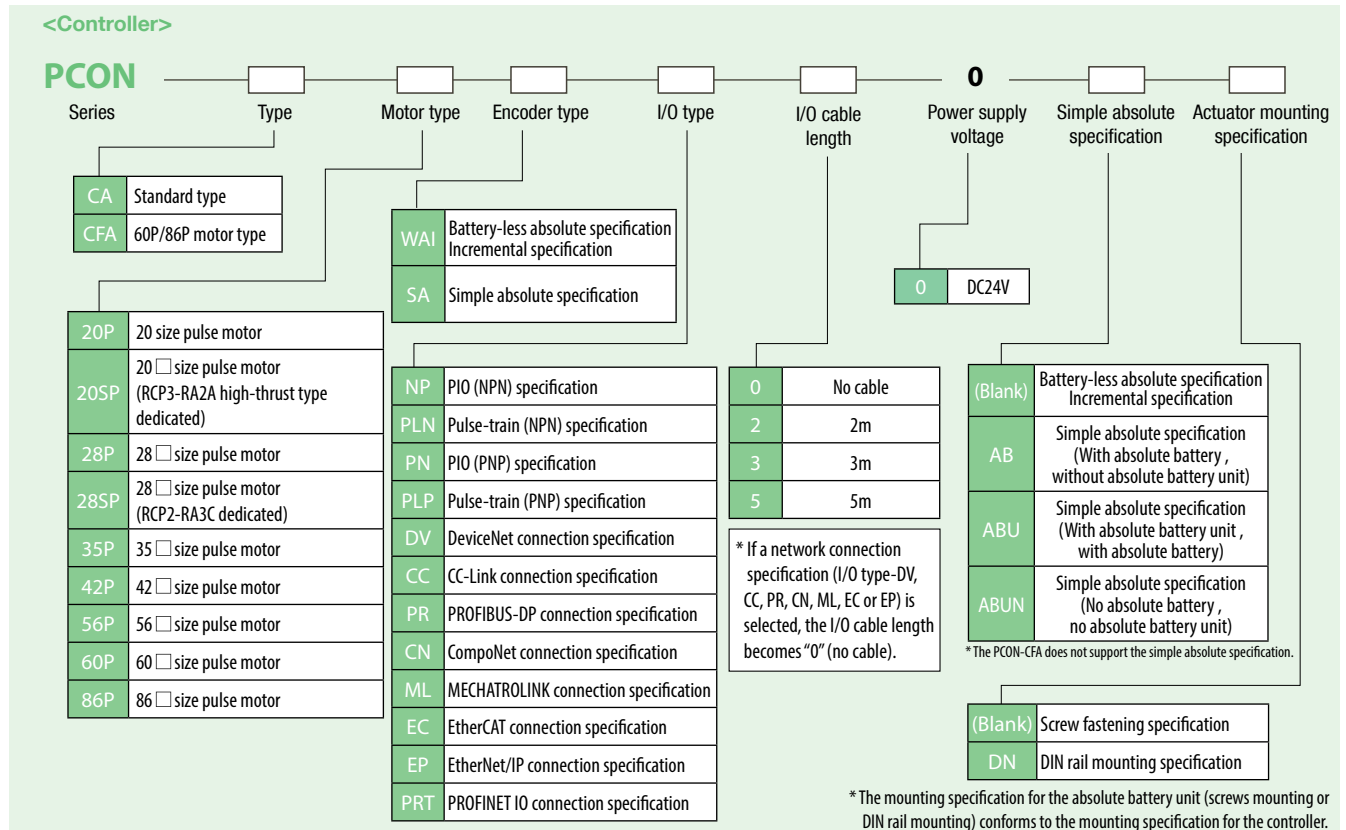

PIO I/O Interface

Input Part External Input Specifications

Item	Specification
Input voltage	DC24V ±10%
Input current	5 mA, 1 circuit
ON/OFF voltage	ON voltage: 18 VDC min. OFF voltage: 6 VDC max.

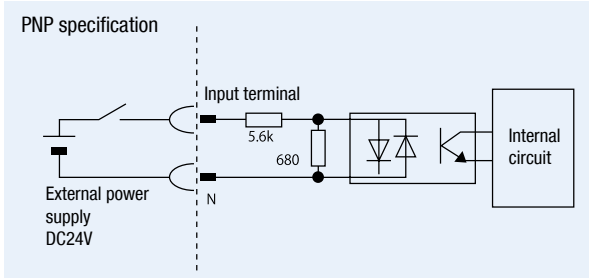
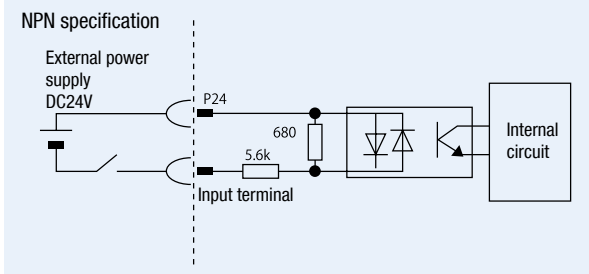

Output Part External Output Specifications

Item	Specification
Load voltage	DC24V
Maximum load current	50 mA, 1 circuit
Leak current	2 mA max. per point

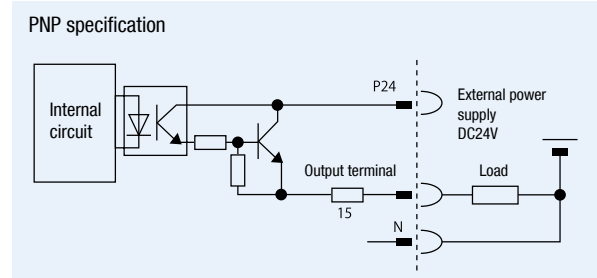
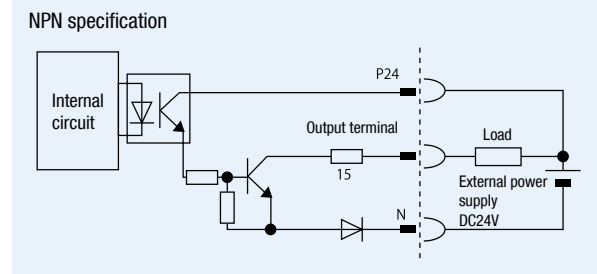

Types of PIO Patterns (Control Patterns)

This controller supports seven types of control methods. Select in Parameter No. 25, "PIO pattern selection" the PIO pattern that best suits your purpose of use.

Type	Set value of Parameter No. 25	Mode	Overview
PIO pattern 0	0 (factory setting)	Positioning mode (standard type)	<ul style="list-style-type: none"> Number of positioning points: 64 points Position number command: Binary Coded Decimal (BCD) Zone signal output*1: 1 point Position zone signal output*2: 1 point
PIO pattern 1	1	Teaching mode (teaching type)	<ul style="list-style-type: none"> Number of positioning points: 64 points Position number command: Binary Coded Decimal (BCD) Position zone signal output*2: 1 point Jog (inching) operation using PIO signals is supported. Current position data can be written to the position table using PIO signals.
PIO pattern 2	2	256-point mode (256 positioning points)	<ul style="list-style-type: none"> Number of positioning points: 256 points Position number command: Binary Coded Decimal (BCD) Position zone signal output*2: 1 point
PIO pattern 3	3	512-point mode (512 positioning points)	<ul style="list-style-type: none"> Number of positioning points: 512 points Position number command: Binary Coded Decimal (BCD) No zone signal output
PIO pattern 4	4	Solenoid valve mode 1 (7-point type)	<ul style="list-style-type: none"> Number of positioning points: 7 points Position number command: Individual number signal ON Zone signal output*1: 1 point Position zone signal output*2: 1 point
PIO pattern 5	5	Solenoid valve mode 2 (3-point type)	<ul style="list-style-type: none"> Number of positioning points: 3 points Position number command: Individual number signal ON Completion signal: A signal equivalent to a LS (limit switch) signal can be output. Zone signal output*1: 1 point Position zone signal output*2: 1 point
PIO pattern 6 (Note 1)	6	Pulse-train control mode	<ul style="list-style-type: none"> Differential pulse input (200 kpps max.) Home return function Zone signal output*1: 2 points No feedback pulse output

*1 Zone signal output: A desired zone is set by Parameter Nos. 1 and 2 or 23 and 24, and the set zone always remains effective once home return has completed.

*2 Position zone signal output: This function is available as part of a position number. A desired zone is set in the position table and becomes effective only when the corresponding position is specified, but not with commands specifying other positions.

(Note 1) Pulse Train Control Model is available only if the pulse train control type is indicated (from PCON-CA-PLN and PLP) at the time of purchase.

PIO Patterns and Signal Assignments

The table below lists the signal assignments for the I/O flat cable under different PIO patterns. Connect an external device (such as a PLC) according to this table.

Pin number	Category	PIO function	Parameter No. 25, "PIO pattern selection"					
			0	1	2	3	4	5
			Positioning mode	Teaching mode	256-point mode	512-point mode	Solenoid valve mode 1	Solenoid valve mode 2
	Input	Number of positioning points	64 points	64 points	256 points	512 points	7 points	3 points
		Home return signal	○	○	○	○	○	×
		Jog signal	×	○	×	×	×	×
		Teaching signal (writing of current position)	×	○	×	×	×	×
	Output	Brake release	○	×	○	○	○	○
		Moving signal	○	○	×	×	×	×
		Zone signal	○	△ (Note 1)	△ (Note 1)	×	○	○
		Position zone signal	○	○	○	×	○	
1A	24V	P24						
2A	24V	P24						
3A	Pulse input	—						
4A		—						
5A	Input	IN0	PC1	PC1	PC1	PC1	ST0	ST0
6A		IN1	PC2	PC2	PC2	PC2	ST1	ST1(JOG+)
7A		IN2	PC4	PC4	PC4	PC4	ST2	ST2(Non-Functional)
8A		IN3	PC8	PC8	PC8	PC8	ST3	—
9A		IN4	PC16	PC16	PC16	PC16	ST4	—
10A		IN5	PC32	PC32	PC32	PC32	ST5	—
11A		IN6	—	MODE	PC64	PC64	ST6	—
12A		IN7	—	JISL	PC128	PC128	—	—
13A		IN8	—	JOG+	—	PC256	—	—
14A		IN9	BKRL	JOG-	BKRL	BKRL	BKRL	BKRL
15A		IN10	RMOD	RMOD	RMOD	RMOD	RMOD	RMOD
16A		IN11	HOME	HOME	HOME	HOME	HOME	—
17A		IN12	*STP	*STP	*STP	*STP	*STP	—
18A		IN13	CSTR	CSTR/PWRT	CSTR	CSTR	—	—
19A		IN14	RES	RES	RES	RES	RES	RES
20A	IN15	SON	SON	SON	SON	SON	SON	
1B	Output	OUT0	PM1(ALM1)	PM1(ALM1)	PM1(ALM1)	PM1(ALM1)	PE0	LS0
2B		OUT1	PM2(ALM2)	PM2(ALM2)	PM2(ALM2)	PM2(ALM2)	PE1	LS1(TRQS)
3B		OUT2	PM4(ALM4)	PM4(ALM4)	PM4(ALM4)	PM4(ALM4)	PE2	LS2 (Note2)
4B		OUT3	PM8(ALM8)	PM8(ALM8)	PM8(ALM8)	PM8(ALM8)	PE3	—
5B		OUT4	PM16	PM16	PM16	PM16	PE4	—
6B		OUT5	PM32	PM32	PM32	PM32	PE5	—
7B		OUT6	MOVE	MOVE	PM64	PM64	PE6	—
8B		OUT7	ZONE1	MODES	PM128	PM128	ZONE1	ZONE1
9B		OUT8	PZONE/ZONE2	PZONE/ZONE1	PZONE/ZONE1	PM256	PZONE/ZONE2	PZONE/ZONE2
10B		OUT9	RMDS	RMDS	RMDS	RMDS	RMDS	RMDS
11B		OUT10	HEND	HEND	HEND	HEND	HEND	HEND
12B		OUT11	PEND	PEND/WEND	PEND	PEND	PEND	—
13B		OUT12	SV	SV	SV	SV	SV	SV
14B		OUT13	*EMGS	*EMGS	*EMGS	*EMGS	*EMGS	*EMGS
15B		OUT14	*ALM	*ALM	*ALM	*ALM	*ALM	*ALM
16B	OUT15	LOAD/TRQS *ALML	*ALML	LOAD/TRQS *ALML	LOAD/TRQS *ALML	LOAD/TRQS *ALML	*ALML	
17B	Pulse input	—						
18B		—						
19B	0V	N						
20B	0V	N						

(Note) In the table above, asterisk * symbol accompanying each code indicates a negative logic signal. PM1 to PM8 are alarm binary code output signals that are used when an alarm generates.

(Note 1) In all PIO patterns other than 3, this signal can be switched with PZONE by setting Parameter No. 149 accordingly.

(Note 2) The setting will not become effective until the home return is completed.

Reference) Negative logic signal

Signals denoted by * are negative logic signals. Negative logic input signals are processed when turned OFF. Negative logic output signals normally remain ON while the power is supplied, and turn OFF when the signal is output.

Note: The names of the signals above inside () are functions before the unit returns home.

Pulse-train Control Circuit

Host Unit = Differential Type

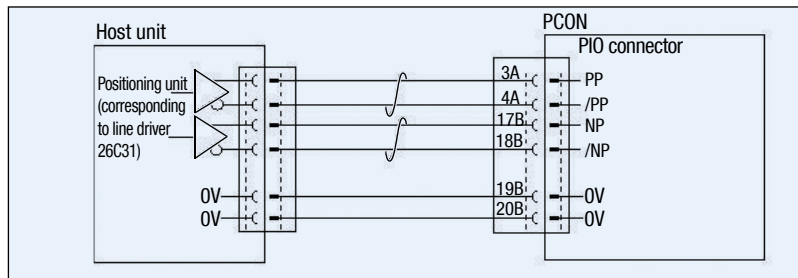

Host Unit = Open Collector Type

The AK-04 (optional) is needed to input pulses.

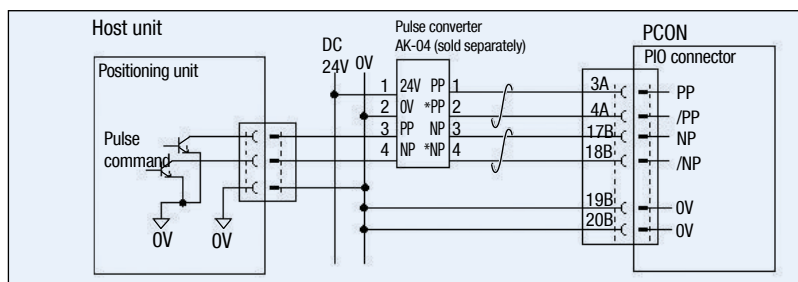

Caution: Use the same power supply for open collector input/output to/from the host and for the AK-04.

Command Pulse Input Patterns

	Command pulse-train pattern	Input terminal	Forward	Reverse	
Negative logic	Forward pulse-train	PP · /PP			
	Reverse pulse-train	NP · /NP			
	A forward pulse-train indicates the amount of motor rotation in the forward direction, while a reverse pulse-train indicates the amount of motor rotation in the reverse direction.				
	Pulse-train	PP · /PP			
	Sign	NP · /NP	Low	High	
	The command pulses indicate the amount of motor rotation, while the sign indicates the rotating direction.				
Positive logic	Forward pulse-train	PP · /PP			
	Reverse pulse-train	NP · /NP			
	Command phases A and B having a 90° phase difference (multiplier is 4) indicate the amount of rotation and the rotating direction.				
	Phase A/B pulse-train	PP · /PP			
	Phase A/B pulse-train	NP · /NP			
	Sign	NP · /NP	High	Low	

I/O Signals in Pulse-train Control Mode

The table below lists the signal assignments for the flat cable in the pulse-train control mode. Connect an external device (such as PLC) according to this table.

Pin number	Category	I/O number	Signal abbreviation	Signal name	Parameter No. 25, "PIO pattern 6"
1A	24V		P24	Power supply	I/O power supply +24 V
2A	24V		P24	Power supply	I/O power supply +24 V
3A	Pulse input		PP	Differential pulse-train input (+)	Differential pulses are input from the host. Up to 200 kpps can be input.
4A			/PP	Differential pulse-train input (-)	
5A	Input	N0	SON	Servo ON	The servo is ON while this signal is ON, and OFF while the signal is OFF.
6A		IN1	RES	Reset	Present alarms are reset when this signal is turned ON.
7A		IN2	HOME	Home return	Home return operation is performed when this signal is turned ON.
8A		IN3	TL	Torque limit selection	When this signal is turned ON, the motor torque is limited to the value set by the parameter.
9A		IN4	CSTP	Forced stop	The actuator is forcibly stopped when this signal has remained ON for 16 ms or more. The actuator decelerates to a stop at the torque set in the controller and the servo turns OFF.
10A		IN5	DCLR	Deviation counter clear	This signal clears the deviation counter.
11A		IN6	BKRL	Forced brake release	The brake is forcibly released.
12A		IN7	RMOD	Operation mode switching	The operation mode can be switched when the MODE switch on the controller is set to AUTO. (AUTO when this signal is OFF, and to MANU when the signal is ON.)
13A		IN8	NC	—	Not used
14A		IN9	NC	—	Not used
15A		IN10	NC	—	Not used
16A		IN11	NC	—	Not used
17A		IN12	NC	—	Not used
18A		IN13	NC	—	Not used
19A		IN14	NC	—	Not used
20A	IN15	NC	—	Not used	
1B	Output	OUT0	PWR	System ready	This signal turns ON when the controller becomes ready after the main power has been turned on.
2B		OUT1	SV	Servo ON status	This signal turns ON when the servo is ON.
3B		OUT2	INP	Positioning complete	This signal turns ON when the amount of remaining travel pulses in the deviation counter falls within the in-position band.
4B		OUT3	HEND	Home return complete	This signal turns ON upon completion of home return.
5B		OUT4	TLR	Torque limited	This signal turns ON upon reaching the torque limit while the torque is limited.
6B		OUT5	*ALM	Controller alarm status	This signal turns ON when the controller is normal, and turns OFF when an alarm generates.
7B		OUT6	*EMGS	Emergency stop status	This signal turns ON when the emergency stop of the controller is cancelled, and turns OFF when an emergency stop is actuated.
8B		OUT7	RMDS	Operation mode status	The operation mode status is output. This signal turns ON when the controller is in the manual mode.
9B		OUT8	ALM1	Alarm code output signal	An alarm code is output when an alarm generates. For details, refer to the operation manual.
10B		OUT9	ALM2		
11B		OUT10	ALM4		
12B		OUT11	ALM8		
13B		OUT12	*ALML	Minor failure alarm	This signal is output when a message-level alarm generates.
14B		OUT13	NC	—	Not used
15B		OUT14	ZONE1	Zone signal 1	This signal turns ON when the current position of the actuator falls within the parameter-set range.
16B	OUT15	ZONE2	Zone signal 2		
17B	Pulse input		NP	Differential pulse-train input (+)	Differential pulses are input from the host. Up to 200 kpps can be input.
18B			/NP	Differential pulse-train input (-)	
19B	0V		N	Power supply	I/O power supply 0 V
20B	0V		N	Power supply	I/O power supply 0 V

(Note) * indicates a negative logic signal. Negative logic signals are normally ON while the power is supplied, and turn OFF when the signal is output.

(Note) The number of encoder pulses is 800 with all RCP5 series models. For details, refer to the operation manual.

Field Network Specification: Explanation of Operation Modes

If the PCON-CA is controlled via a field network, you can select one of the following five modes to operate the actuator. Take note that the required data areas on the PLC side vary depending on the mode.

Mode Description

	Mode	Description
0	Remote I/O mode	In this mode, the actuator is operated by controlling the ON/OFF of bits via the network, just like with the PIO specification. The number of positioning points and functions vary with each of the operation patterns (PIO patterns) that can be set by the controller's parameter.
1	Position/simple direct numerical mode	The target position is specified by directly entering a value, while other operating conditions (speed, acceleration, etc.) are set by specifying the desired position number corresponding to the desired operating conditions already input to the position data table.
2	Half direct numerical mode	The actuator is operated by specifying the speed, acceleration/deceleration and push current, in addition to the target position, by directly entering values.
3	Full direct numerical mode	The actuator is operated by specifying the target position, speed, acceleration/deceleration, push current control value, etc., by directly entering values. The current position, current speed, command current, etc., can also be read.
4	Remote I/O mode 2	Same as the above remote I/O mode, plus the current position read function and command current read function.

Required Data Size for Each Network

		DeviceNet	CC-Link	PROFIBUS-DP	CompoNet	MECHATROLINK I,II	EtherCAT	EtherNet/IP
0	Remote I/O mode	1CH	1 station	2 bytes	2 bytes	*	2 bytes	2 bytes
1	Position/simple direct numerical mode	4CH	1 station	8 bytes	8 bytes	*	8 bytes	8 bytes
2	Half direct numerical mode	8CH	2 stations	16 bytes	16 bytes	*	16 bytes	16 bytes
3	Full direct numerical mode	16CH	4 stations	32 bytes	32 bytes	*	32 bytes	32 bytes
4	Remote I/O mode 2	6CH	1 station	12 bytes	12 bytes	*	12 bytes	12 bytes

* No required data size is set for MECHATROLINK I and II.

List of Functions by Operation Mode

	Remote I/O mode	Position/simple direct numerical mode	Half direct numerical mode	Full direct numerical mode	Remote I/O mode 2
Number of positioning points	512 points	768 points	Unlimited	Unlimited	512 points
Operation by direct position data specification	×	○	○	○	×
Direct speed/acceleration specification	×	×	○	○	×
Push-motion operation	○	○	○	○	○
Current position read	×	○	○	○	○
Current speed read	×	×	○	○	×
Operation by position number specification	○	○	×	×	○
Completed position number read	○	○	×	×	○

* ○ indicates that the operation is supported, and X indicates that it is not supported.

(Note 1) Take note that the MECHATROLINK specification does not support the full direct numerical mode.

External Dimensions

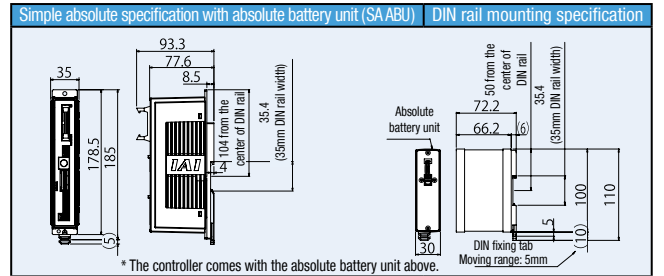
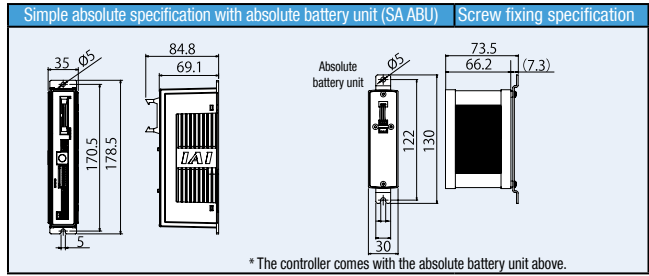
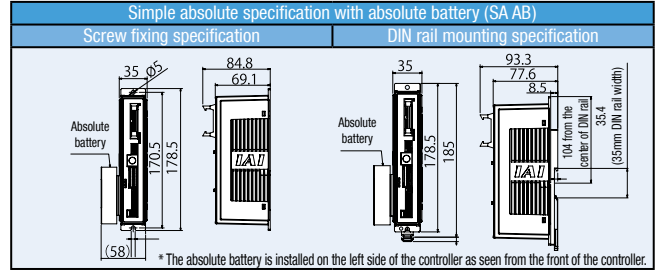
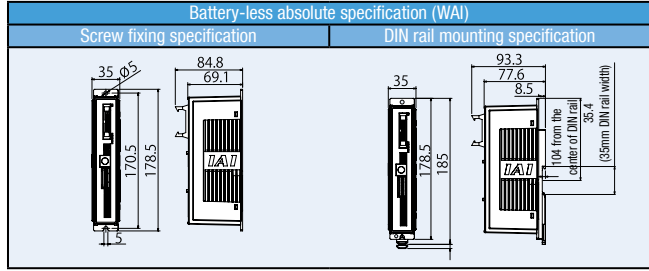

PCON-CFA

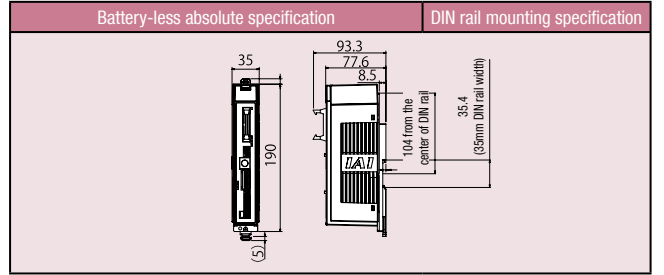
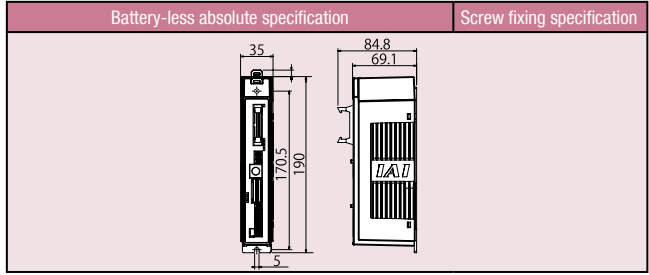

Specification List

Item				Description	
				PCON-CA	PCON-CFA
Number of controlled axes				1 axis	
Power-supply voltage				DC24V±10%	
Load current (including control-side current consumption) (Note 1)	RCP2 RCP3	Motor type	20P, 28P, 28SP	1 A max.	
			42P, 56P 60P, 86P	2.2 A max.	
	RCP4 RCP5	Motor type	28P, 35P, 42P, 56P	High-output setting disabled: 2.2 A max.	
			60P, 86P	High-output setting enabled: 3.5 A rated / 4.2 A max.	
Electromagnetic brake power (for actuator with brake)				DC24V ±10% 0.15A (max)	DC24V ±10% 0.5A (max)
Rush current (Note 2)				8.3A	
Momentary power failure resistance				MAX.500µs	
Supported encoder				Battery-less absolute encoder/incremental encoder	
Actuator cable length				20m max.	
External interface		PIO specification		Dedicated 24-VDC signal inputs/outputs (NPN/PNP selectable) --- Up to 16 input points, up to 16 output points, cable length up to 10m	
		Field network specification		DeviceNet, CC-Link, PROFIBUS-DP, CompoNet, MECHATROLINK-II, EtherCAT, EtherNet/IP	
Data setting, input method				PC software, touch panel teaching pendant, teaching pendant	
Data retention memory				Position data and parameters are saved in non-volatile memory. (There are no limits to how many times the memory can be rewritten.)	
Operation mode				Positioner mode/pulse-train control mode (selectable by parameter setting)	
Number of positioner-mode positions				Up to 512 points for positioner type or up to 768 points for network type (Note) The total number of positioning points varies depending on which PIO pattern is selected.	
Pulse-train interface		Input pulses		Differential type (line-driver type): 200 kpps max., cable length up to 10m	
				Open-collector type: Not supported.	
		Command pulse magnification (Electronic gear: A/B)		1/50 < A/B < 50/1	
		Feedback pulse output		Setting range of A and B (set by parameters): 1 to 4096	
				None	
Insulation resistance				Not less than 10 MΩ at 500 VDC,	
Electric shock protection mechanism				Class I, basic insulation	
Mass (Note 3)		Incremental specification		Screw fixing type: Not more than 250g / DIN rail fixing type: Not more than 285g	Screw fixing type: Not more than 270g / DIN rail fixing type: Not more than 305g
		Simple absolute specification (including 190 g for battery)		Screw fixing type: Not more than 450g / DIN rail fixing type: Not more than 485g	
Cooling method				Natural cooling by air	
				Forced cooling by air	
Environment		Ambient operating temperature		0 to 40°C	
		Ambient operating humidity		Not more than 85% RH (non-condensing)	
		Operating ambience		Free from corrosive gases	
		Degree of protection		IP20	

Note 1) 0.3 A higher for the field network specification.

Note 2) Rush current flows for approx. 5 msec after the power is input (at 40°C). Exercise caution that the rush current value varies depending on the impedance of the power line.

Note 3) 30 g heavier for the field network specification.



Position Controller, 8-axis Type
6-axis Type with PLC Function

1 Added PLC function

MSEP-LC

Operating the actuator and controlling the ON/OFF of I/O (input/output) signals using a ladder logic program is now possible. If your equipment is small enough, the MSEP-LC is all you need to control it. If your equipment is larger in size, you can still use the MSEP-LC to perform distributed control for each process to reduce the load of the main PLC. The MSEP-LC also makes your program simpler and troubleshooting easier.

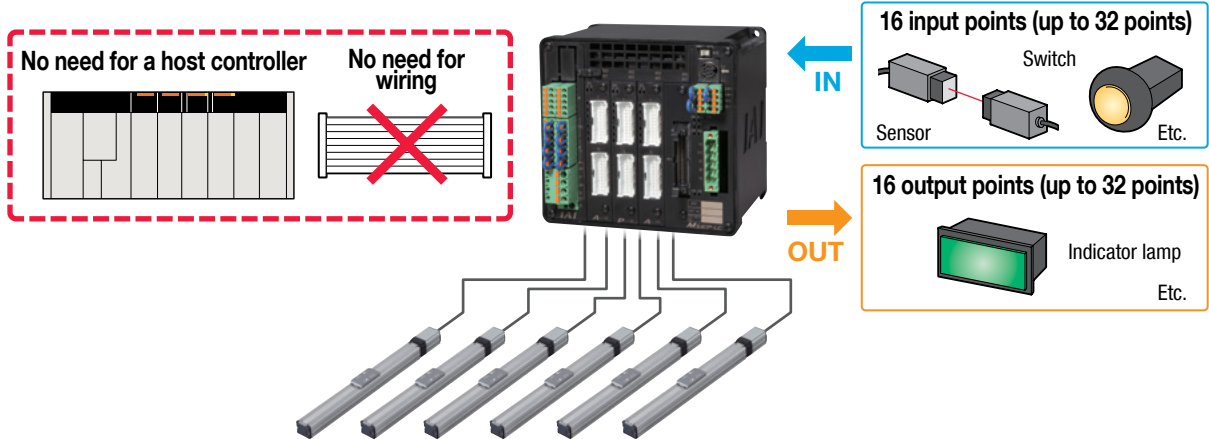

2 Supporting actuators with the battery-less absolute encoder

MSEP-LC MSEP-C

Features of actuators with the battery-less absolute encoder

- 1 Home return is no longer necessary, so these actuators start and restart quicker than incremental actuators to begin working right away. They are also free from problems relating to home return, such as position shift.
- 2 Compared to standard absolute actuators, no battery is required, which results in the following benefits:
 - ▶ No need to purchase or replace batteries
 - ▶ No need to control the stocks and replacement timing of batteries
 - ▶ No need to make adjustment (absolute reset) normally required after battery replacement

ROBO Cylinder with the battery-less absolute encoder

RCP5



3 Supporting the Power CON (high-output driver) and Mini Cylinder

MSEP-LC MSEP-C

When the Power CON (newly developed high-output driver) is installed and combined with the RCP5 or RCP4, high performance is realized as indicated by the maximum speed of 1.5 times faster than that of conventional models and payload of more than double.

Since the super-compact Mini Cylinders are also supported, you have a greater range of actuator variations--from small to large--to choose from.

Maximum speed vs. conventional models **1.5 times faster**

Payload vs. conventional models **more than Double**

Power CON supported
RCP5-SA RCP5-RA

Mini Cylinder
RCD-RA

Choice of 6 boards to install

- 1 Pulse motor board
- NEW** 2 Pulse motor board for battery-less absolute specification
- NEW** 3 Power CON (pulse high-output motor) board
- NEW** 4 Power CON board for battery-less absolute specification
- 5 AC servo motor board
- NEW** 6 Mini Cylinder (DC servo motor) board

* Boards 3 and 4 permit operation of only one axis per board.

4 Supporting field networks

MSEP-LC MSEP-C

DeviceNet, CC-Link, PROFIBUS-DP, CompoNet, EtherCAT, EtherNet/IP and other major field networks are directly accessible.

Features of the network specification

- ▶ 256 positioning points per axis
- ▶ Numerically specify the target position or speed to move to
- ▶ Checking the current position in real time
- ▶ Substantially shorter communications time inside the controller (approx. one-tenth of conventional models)

DeviceNet PROFIBUS
CompoNet CC-Link
EtherNet/IP EtherCAT
(To be released in May 2014)

Available Soon

5 Free ladder logic support software will be downloadable from our website

MSEP-LC

Ladder logic support software will be available for free download from our website. You can create a ladder program before purchasing any product.

Free www.intelligentactuator.com/lc-ladder/

LC-LADDER

Application Examples

Rear panel positioning system

Shifted work parts are aligned by the “push motion” of the ROBO Cylinder as they enter the machining stage for automotive rear panels. One controller can handle multiple axes, so wiring is easy.

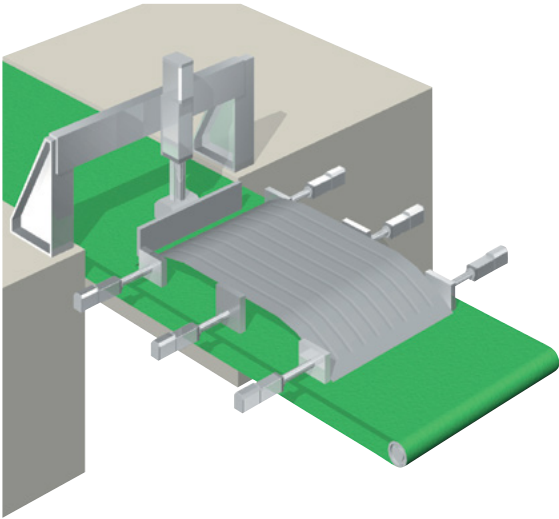

Palletizing system

Should the system halt due to an emergency stop, etc., it can resume operation right away thanks to the battery-less absolute encoder.

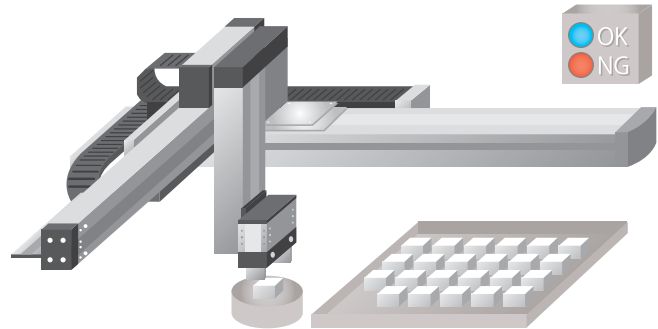

Transferring work parts between machining systems

Work parts can be transferred between systems without using a dedicated PLC.

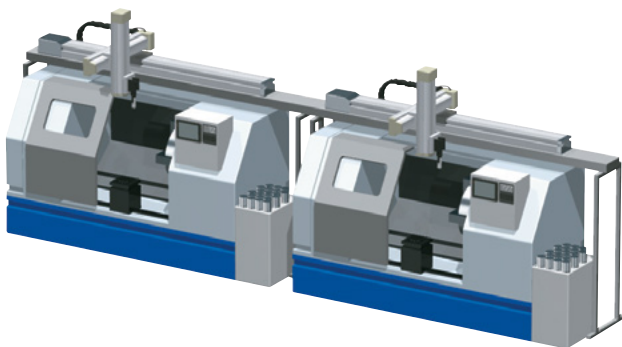

Positioning on an automotive manufacturing line

In the case of a large-scale line, implementing distributed control of each process and connecting to the host controller via a field network reduces the control load of the host controller.

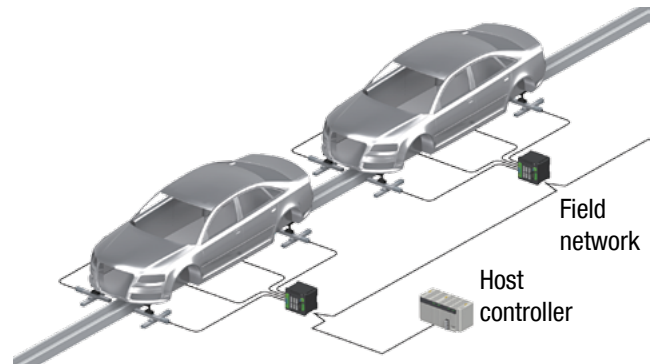

MSEP Controller Models

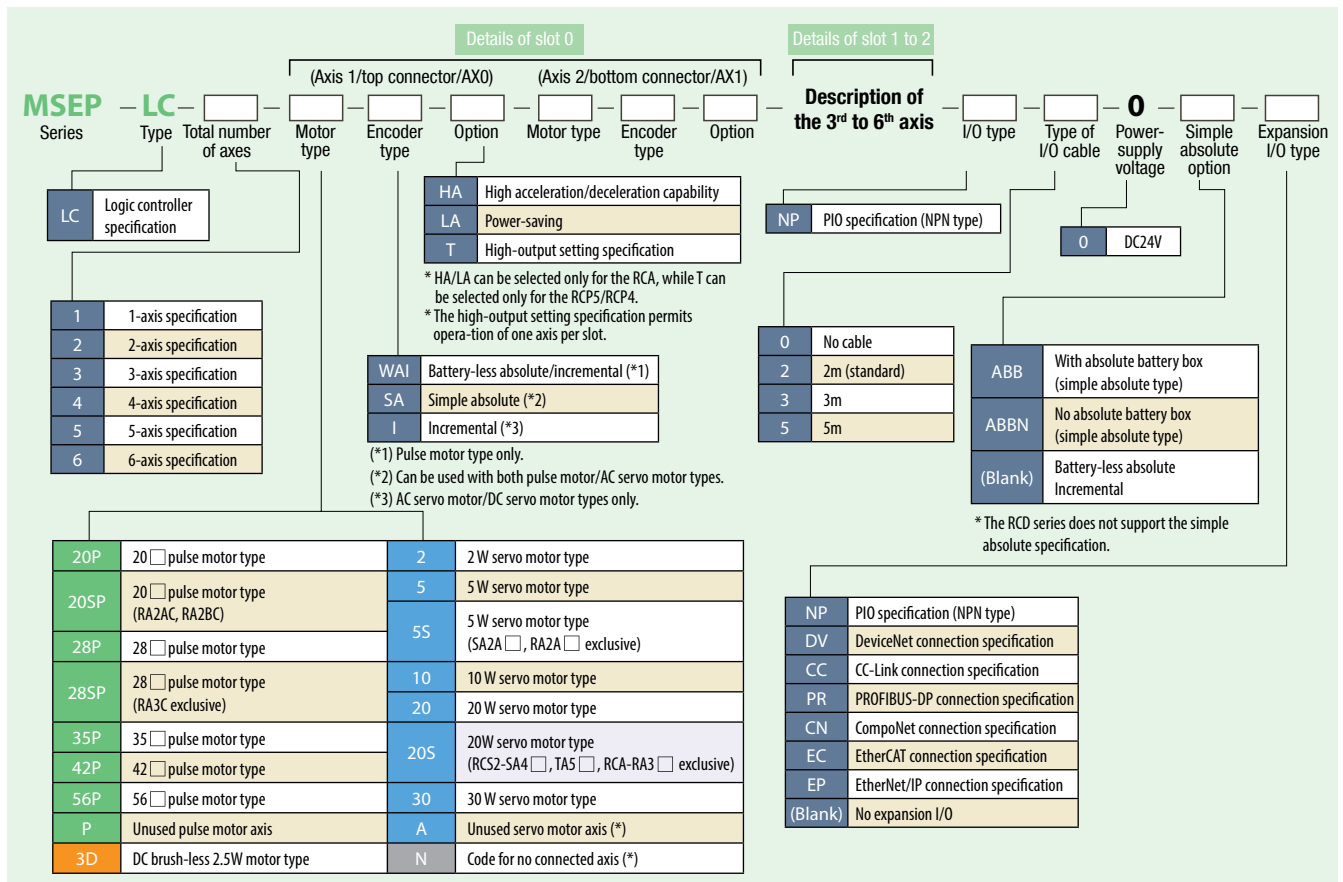
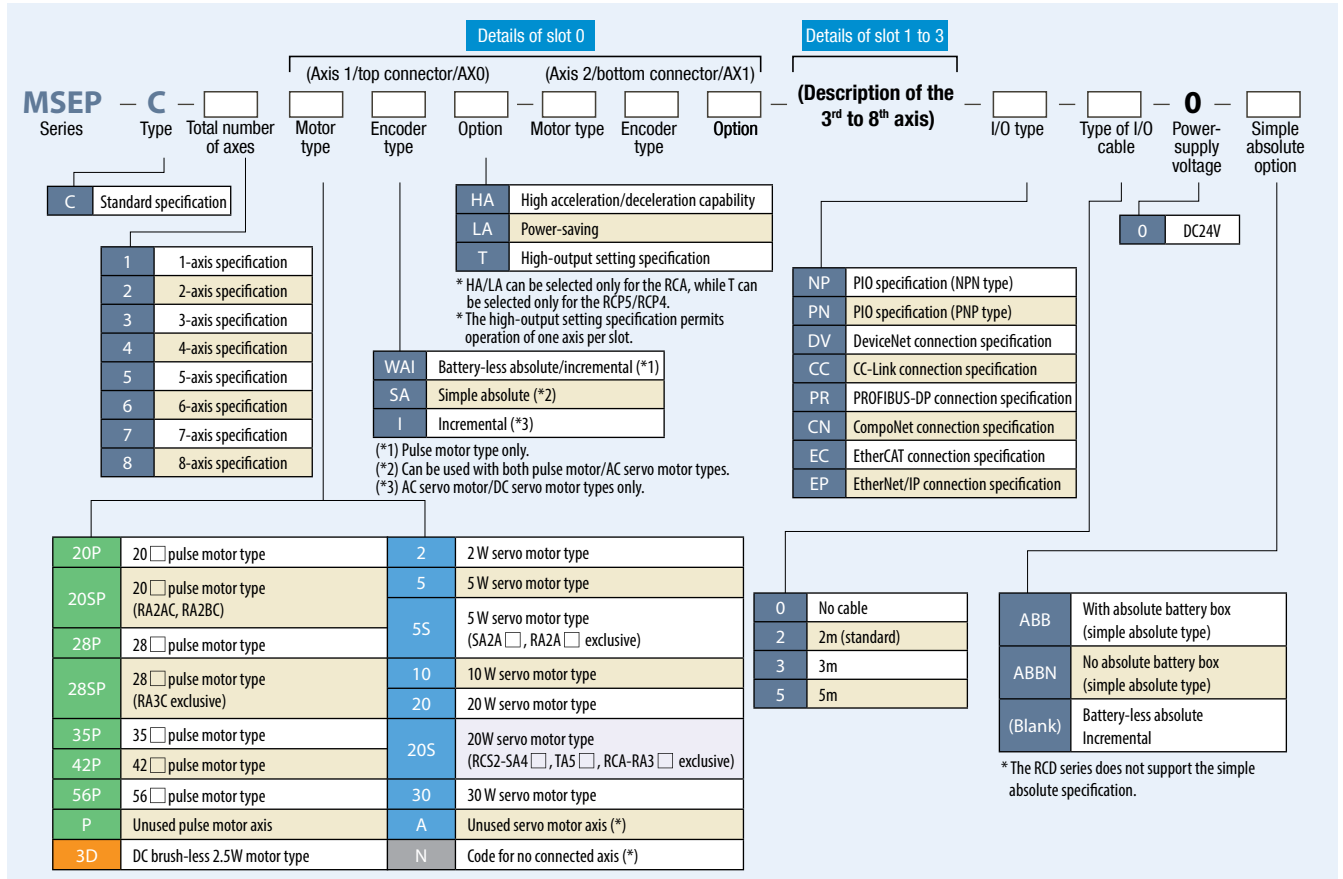

How to Operate the MSEP-C

PIO Specification

Input position data to the MSEP-C and specify a desired position number via PIO from the host PLC to operate the actuator.

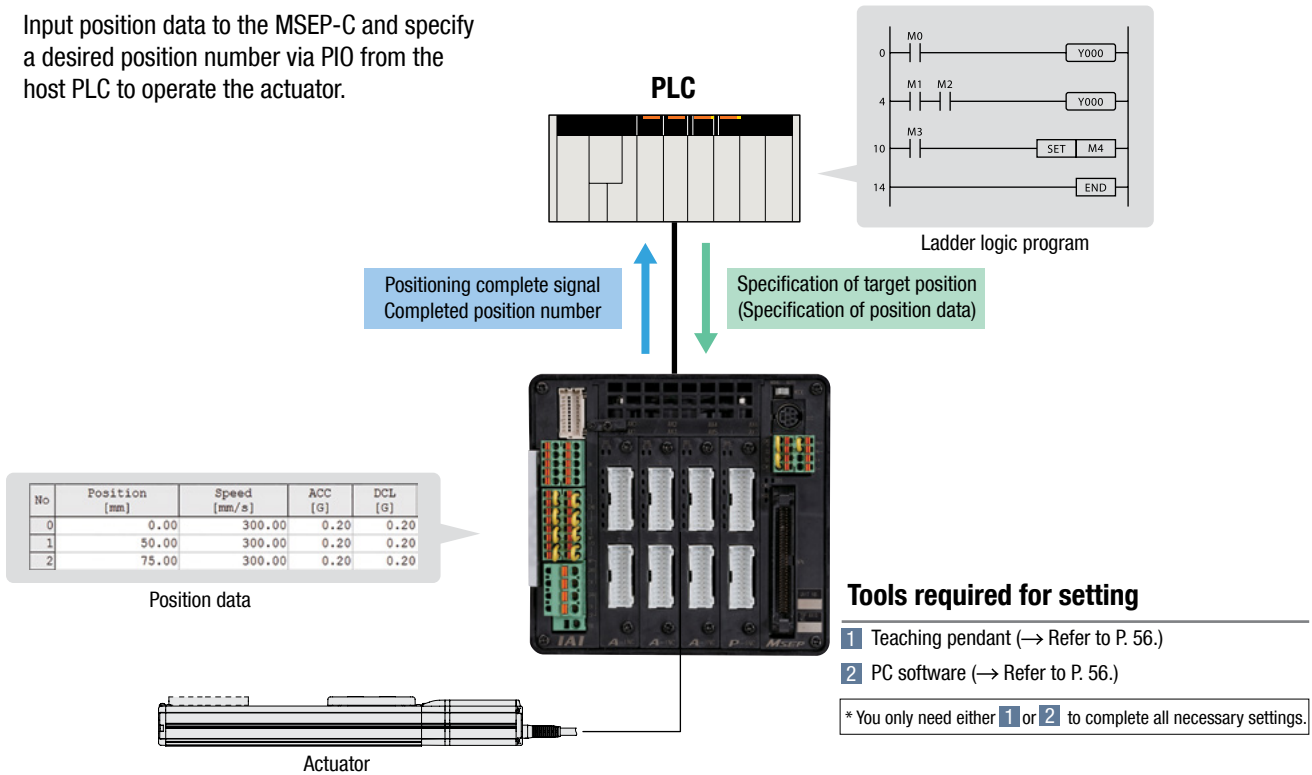

Field Network Specification

- As with the PIO specification, input position data to the MSEP and specify a desired position number via a field network from the PLC to operate the actuator.
- The PLC sends numerical position, speed and other data via a field network to operate the actuator.

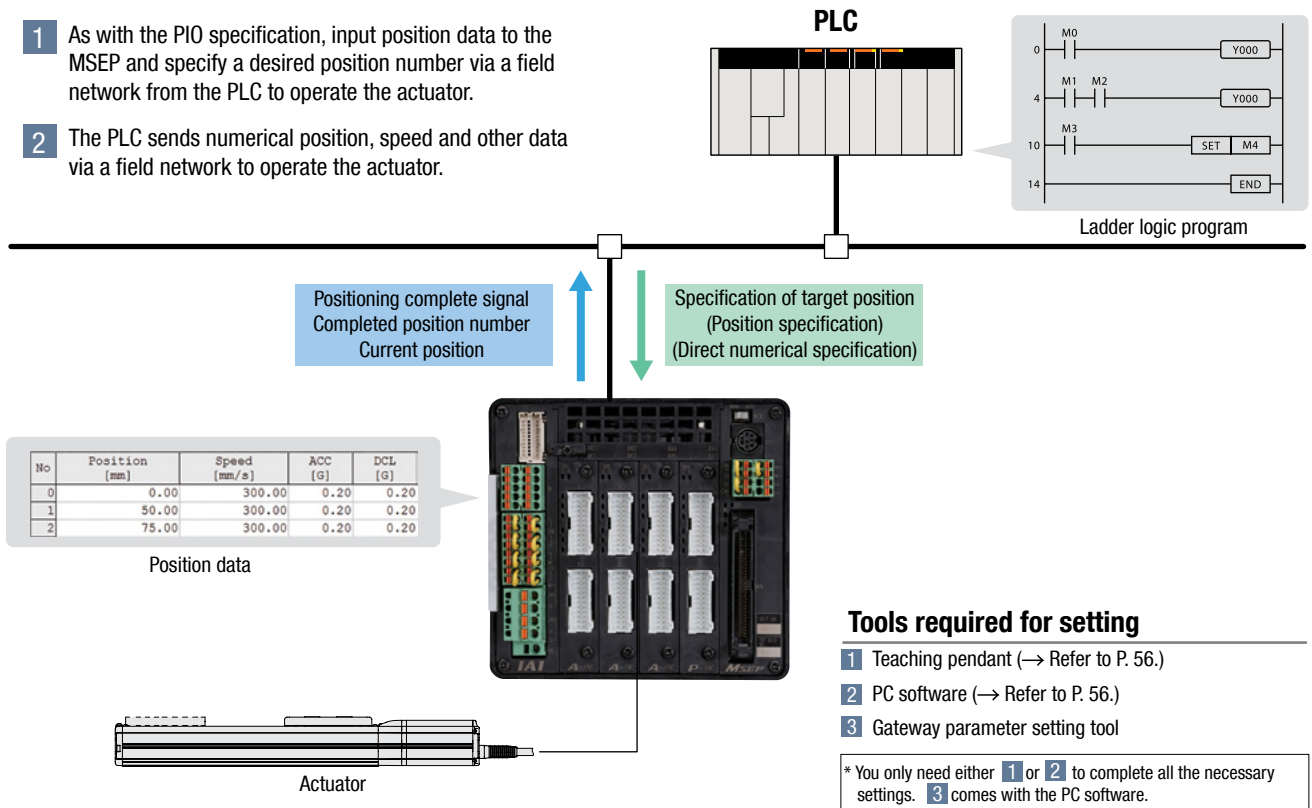

How to Operate the MSEP-LC

PIO Specification

The MSEP-LC runs a ladder logic program internally to operate the axis and control the PIO I/O signals. The axis can be operated either by using position data or specifying coordinates directly.

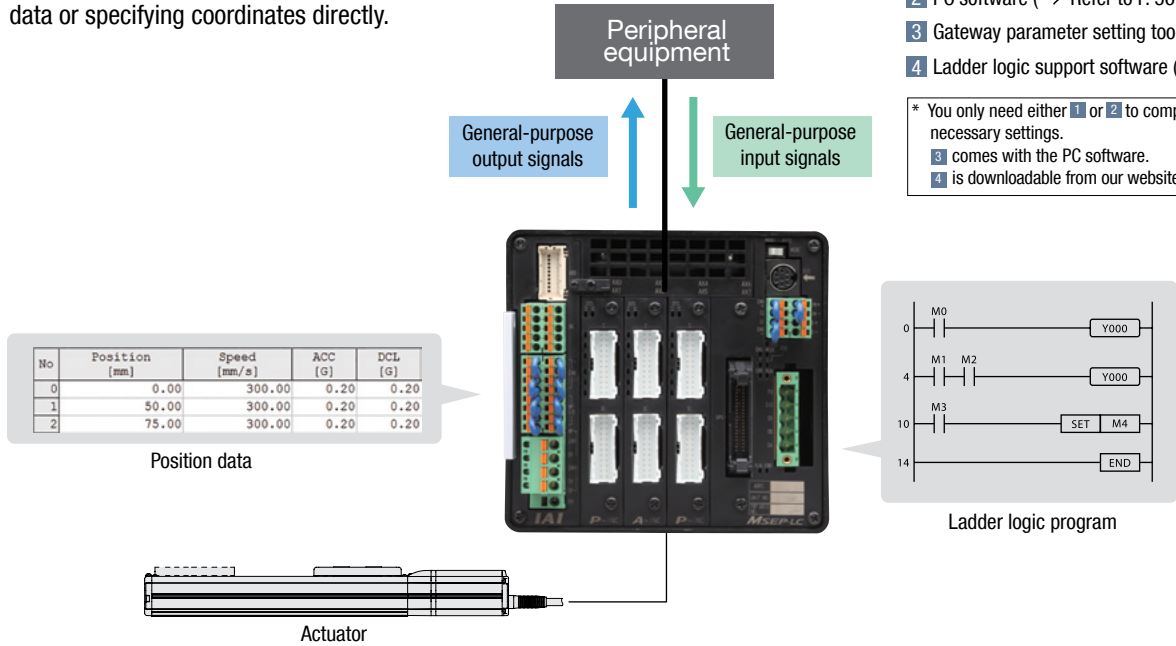

Tools required for setting

- 1 Teaching pendant (→ Refer to P. 56.)
- 2 PC software (→ Refer to P. 56.)
- 3 Gateway parameter setting tool
- 4 Ladder logic support software (→ Refer to P. 48.)

* You only need either 1 or 2 to complete all the necessary settings.
 3 comes with the PC software.
 4 is downloadable from our website. Available Soon

Field Network Specification

The MSEP-LC runs a ladder logic program internally to operate the axis and control I/O signals via a network. The axis can be operated either by using position data or specifying coordinates directly.

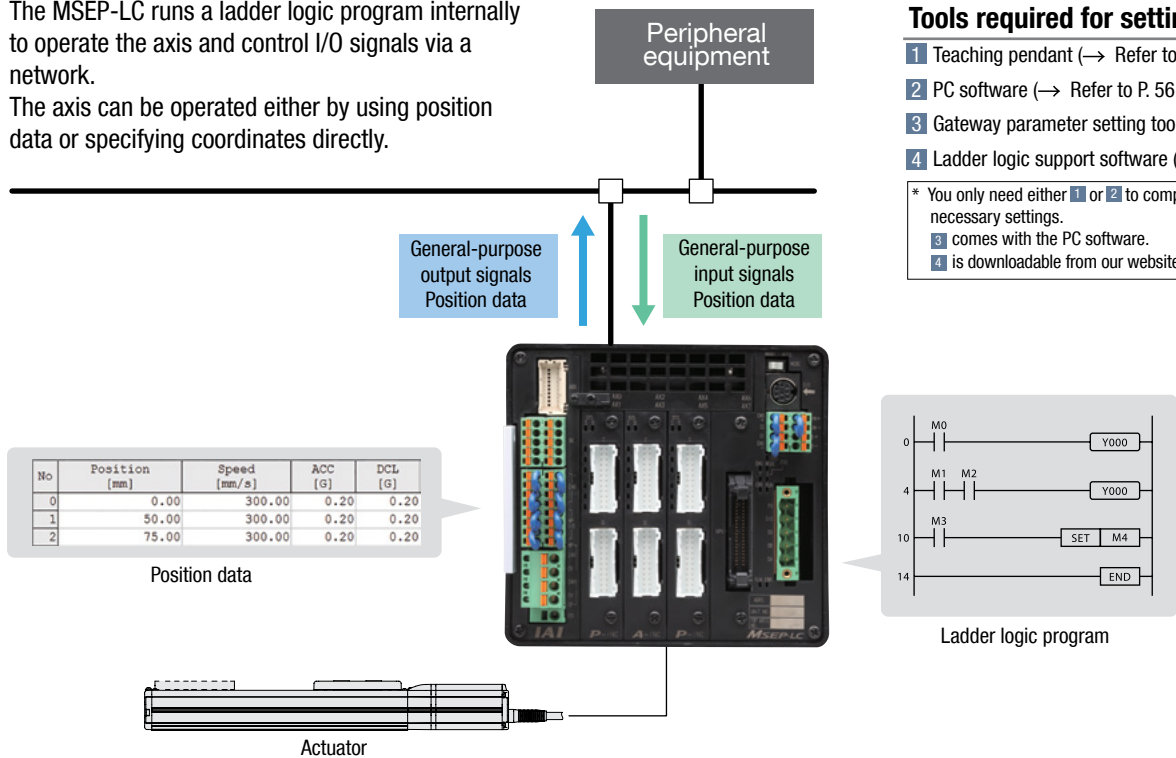

Tools required for setting

- 1 Teaching pendant (→ Refer to P. 56.)
- 2 PC software (→ Refer to P. 56.)
- 3 Gateway parameter setting tool
- 4 Ladder logic support software (→ Refer to P. 48.)

* You only need either 1 or 2 to complete all necessary settings.
 3 comes with the PC software.
 4 is downloadable from our website. Available Soon

Names of the MSEP Controller Components

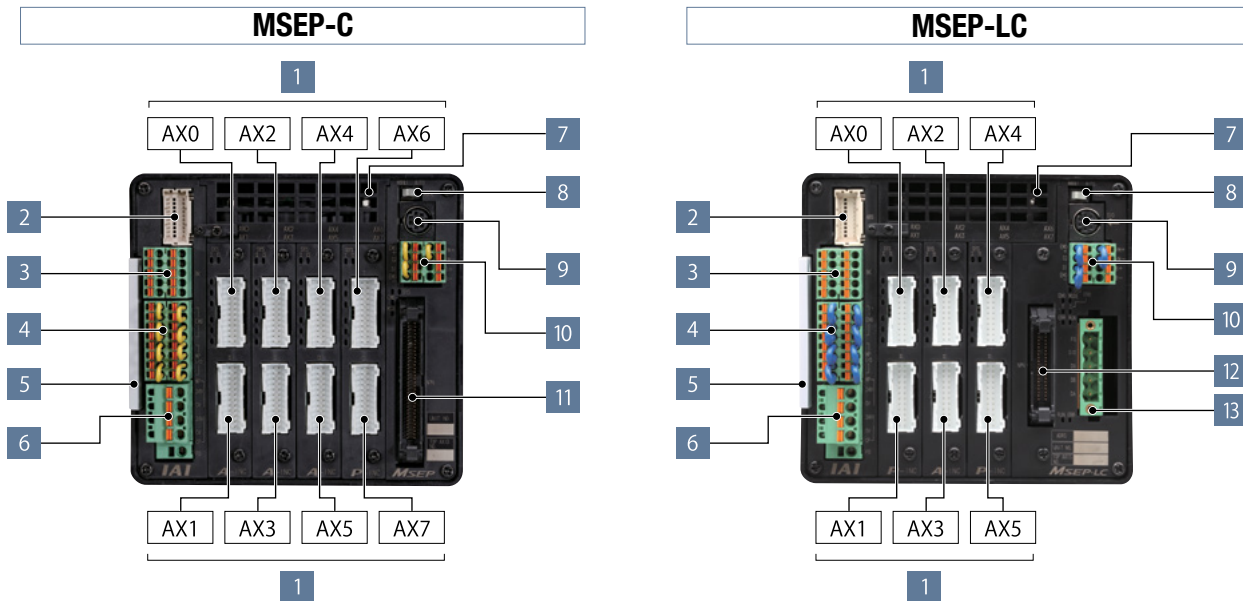

Caution: With the high-output setting specification (Power CON), only one axis can be connected per slot.

Descriptions of the components

- 1 Motor-encoder connectors for the actuator connection**
Connect motor-encoder cable to the actuator
- 2 Connector for the absolute data backup battery**
Connect the absolute data backup battery if the controller has the absolute position encoder specification
- 3 Connector for the external brake input**
The connector to input a signal to release the brake for the actuator externally.
- 4 Connector for the emergency stop input for power source shut-off**
The emergency stop input connector to connect in/output terminal of the external relay of the motor drive shut-off and each driver slot (*).
- 5 Information card for configuration of the connecting axes**
The information card contains information regarding the configuration of the controller axes which is removable to examine the contents.
- 6 +24 V power source input connector**
The main power source connector for the controller: Motor drive source shut-down is possible while restoring the power source for the controller unit in case of an emergency shut-down; This is because the terminals for the power source of the motor and the controller are separate.
- 7 Fan unit**
Easily replaceable fan unit. (Replacement fan unit: Model MSEP-FU)
- 8 AUTO/MANUAL switch**
To switch automatic operation to/from manual operation
- 9 SIO connector**
To connect teaching box and the connecting cable for PC software
- 10 System I/O connector**
The connector for remote AUTO/MANU switch input and emergency stop input for the entire controller with functions including an external regeneration-resistance expansion terminal.
- 11 PIO connector/ field network connection connector (MSEP-C only)**
The PIO specification - connects to a 68-pin ribbon I/O cable.
The field network specification - connects to a field network type specified on the MSEP controller.
- 12 Standard I/Os (MSEP-LC only)**
The MSEP-LC comes installed with a 40-pin PIO connector as standard equipment.
- 13 Expansion I/Os (MSEP-LC only)**
Expansion I/Os can be installed as an option.
Available I/O types include PIO, DeviceNet, CC-Link, PROFIBUS-DP, CompoNet, Ethernet/IP and EtherCAT.

(*1) The shut-off feature is available on a single slot basis which is for two axes per slot. Please note that a single axis basis cannot be accommodated.

Input/Output (PIO) Signals

The MSEP-C has dedicated inputs and outputs set to PIO signals at 34 input points/34 output points. The axis operates when each signal is turned ON/OFF from the host PLC.

With the MSEP-LC, general-purpose input/output signals at 32 input points/32 output points can be used in a ladder logic program by using the standard 16 input points/16 output points plus expansion I/Os.

MSEP-C (PIO specification)

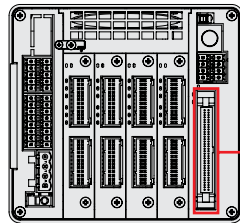

PIO connector

MSEP-LC (Expansion I/O specification)

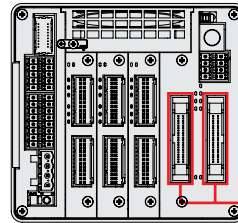

PIO connector

PIO Wiring Diagram for MSEP-C

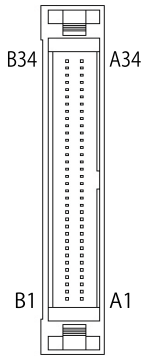

Connector name: HIF6-68PA-1.27DS (Hirose Electric)					
Pin No.	Category	Signal ID	Pin No.	Category	Signal ID
A1	24V	For I/O	A18		OUT0
A2		INO	A19	Output (Axis No. 0)	OUT1
A3	Input (Axis No. 0)	IN1	A20		OUT2
A4		IN2	A21		OUT3
A5		IN3	A22		OUT4
A6		IN4	A23	Output (Axis No. 1)	OUT5
A7	Input (Axis No. 1)	IN5	A24		OUT6
A8		IN6	A25		OUT7
A9		IN7	A26		OUT8
A10		IN8	A27	Output (Axis No. 2)	OUT9
A11	Input (Axis No. 2)	IN9	A28		OUT10
A12		IN10	A29		OUT11
A13		IN11	A30		OUT12
A14		IN12	A31	Output (Axis No. 3)	OUT13
A15	Input (Axis No. 3)	IN13	A32		OUT14
A16		IN14	A33		OUT15
A17		IN15	A34	0V	For I/O

Connector name: HIF6-68PA-1.27DS (Hirose Electric)					
Pin No.	Category	Signal ID	Pin No.	Category	Signal ID
B1	24V	For I/O	B18		OUT16
B2		IN16	B19	Output (Axis No. 4)	OUT17
B3	Input (Axis No. 4)	IN17	B20		OUT18
B4		IN18	B21		OUT19
B5		IN19	B22		OUT20
B6		IN20	B23	Output (Axis No. 5)	OUT21
B7	Input (Axis No. 5)	IN21	B24		OUT22
B8		IN22	B25		OUT23
B9		IN23	B26		OUT24
B10		IN24	B27	Output (Axis No. 6)	OUT25
B11	Input (Axis No. 6)	IN25	B28		OUT26
B12		IN26	B29		OUT27
B13		IN27	B30		OUT28
B14		IN28	B31	Output (Axis No. 7)	OUT29
B15	Input (Axis No. 7)	IN29	B32		OUT30
B16		IN30	B33		OUT31
B17		IN31	B34	0V	For I/O

PIO Wiring Diagram for MSEP-LC

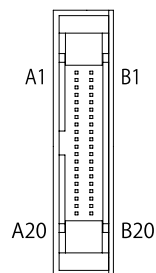

Standard I/Os

Pin No.	Category	Assigned memory	Pin No.	Category	Assigned memory
A1		+24-V external input	A11	Input	X006
A2		external input	A12		X007
A3		Not used	A13		X008
A4		Not used	A14		X009
A5	Input	X000	A15		X00A
A6		X001	A16		X00B
A7		X002	A17		X00C
A8		X003	A18		X00D
A9		X004	A19		X00E
A10		X005	A20		X00F

Pin No.	Category	Assigned memory	Pin No.	Category	Assigned memory
B1	Output	Y000	B11	Output	Y00A
B2		Y001	B12		Y00B
B3		Y002	B13		Y00C
B4		Y003	B14		Y00D
B5		Y004	B15		Y00E
B6		Y005	B16		Y00F
B7			B17		Not used
B8			B18		Not used
B9			B19		0 V external input
B10			Y009		B20

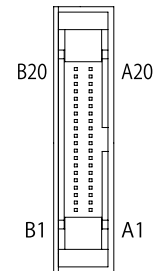

Expansion I/Os

Pin No.	Category	Assigned memory	Pin No.	Category	Assigned memory
A1		+24-V external input	A11	Input	X016
A2		external input	A12		X017
A3		Not used	A13		X018
A4		Not used	A14		X019
A5	Input	X010	A15		X01A
A6		X011	A16		X01B
A7		X012	A17		X01C
A8		X013	A18		X01D
A9		X014	A19		X01E
A10		X015	A20		X01F

Pin No.	Category	Assigned memory	Pin No.	Category	Assigned memory
B1	Output	Y010	B11	Output	Y01A
B2		Y011	B12		Y01B
B3		Y012	B13		Y01C
B4		Y013	B14		Y01D
B5		Y014	B15		Y01E
B6		Y015	B16		Y01F
B7			B17		Not used
B8			B18		Not used
B9			B19		0 V external input
B10			Y019		B20

Table of General Specifications

Specification item		Description					
Number of axes in the controller		8 axes MAX (MSEP-C), 6 axes MAX (MSEP-LC)					
Controller/ Motor input power		DC24V ±10%					
Brake power		0.15 A x Number of axes					
Current consumption by control power		0.8A					
Controller inrush current		5A MAX, under 30 ms					
Motor consumption current	Servo motor type	Rated ampere	Maximum		Pulse motor type	Rated ampere	Maximum
			Energy saver	Standard/Hi-accel./decel.			
	2W	0.8A		4.6A	20P	1.0A	2.0A
	3W(RCD)	0.7A		1.5A	28P	1.0A	2.0A
	5W	1.0A		6.4A	35P	2.2 A (high output disabled)	2.2 A (high output disabled)
	10W(RCL)	1.3A		6.4A			
	10W(RCA/RCA2)		2.5A	4.4A	42P	3.5 A (high output specification)	4.2 A (high output specification)
	20W	1.3A	2.5A	4.4A			
20 W (20S type)	1.7A	3.4A	5.1A	56P	3.5 A (high output specification)	4.2 A (high output specification)	
30W	1.3A	2.2A	4.4A				
Motor inrush current		Slot numbers x 10A MAX, under 5ms					
Motor-encoder cable length		Maximum length 20m (note) for absolute position					
Serial communication (SIO port: dedicated teaching)		RS485 1ch (Modbus protocol compatible) Speed 9.6 to 230.4kbps					
External interface	PIO specification	PIO specification : DC24 V dedicated signal in/output; Maximum input of 4 points/axis; Maximum output of 4 points/axis; Maximum cable length 10 m					
	Field network specification	DeviceNet, CC-Link, PROFIBUS-DP, MECHATROLINK, CompoNet, EtherCAT, EtherNet/IP(*)					
Data configuration and input method		PC software application, touch panel teaching pendant, gateway parameter configuration tool					
Data retention memory		Restore the position data and parameter in non-volatile memory (unlimited input)					
Positioning points		PIO specification: 2 or 3 points Field network specification: 256 points (no limited input for the simple numerical control and the direct numerical control) (Note) The number of designated positions vary depending on the parameter configuration with motion mode selection.					
LED display (On the front panel)		LED for driver status, 8 LEDs (for each driver board) Status LED, 4 LEDs (PIO specification), 7 LEDs (Fieldbus specification)					
Electromagnetic brake force release		Enable to force-release by transmitting a deactivation signal to each axis (DC24 V input).					
Surge protection		Overcurrent protection (A cut-off semiconductor circuit is built-in on each slot)					
Electric shock protection		Class I basic insulation					
Insulation resistance		DC500V 10MΩ					
Weight		620 g with the absolute position encoder specification plus 1950 g absolute data backup battery (8-axis specification)					
Cooling method		Forced- air cooling					
Ambient operating temperature/humidity		0 to 40°C, under 85% RH (non-condensing)					
International Protection code		IP20					

(*) The EtherCAT specification will be available soon.

Exterior Dimensions

Controller (The same dimensions apply to the MSEP-C/LC.)

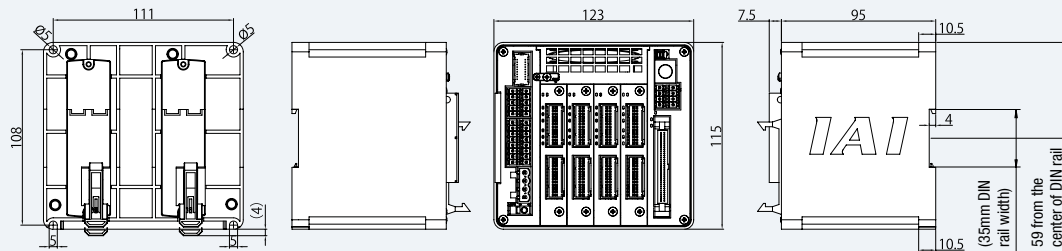

Absolute data backup battery box

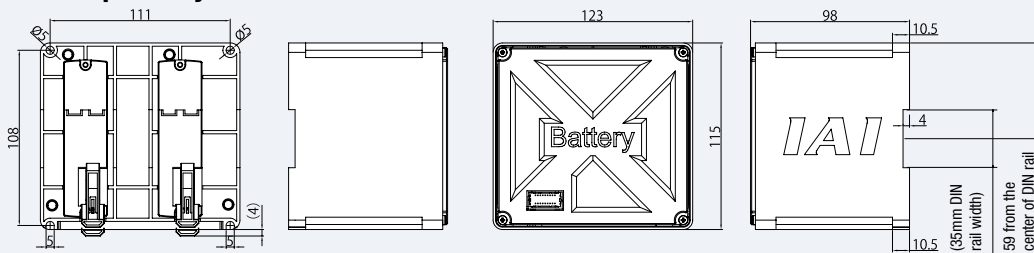

Options

Teaching pendant

Summary Teaching device for positioning input, test operation, and monitoring.

Model **TB-01-C**

Setting



Specification

Rated voltage	24V DC
Power consumption	3.6 W or less (150 mA or less)
Ambient operating temperature	0~50°
Ambient operating humidity	20 to 85%RH (non-condensing)
Environmental resistance	IP40 (initial state)
Weight	507 g (TB-01 unit only)

PC software (Windows only) * For the MSEP field network specification, the PC software is required.

Summary A startup support software for inputting positions, performing test runs, and monitoring. With enhancements for adjustment functions, the startup time is shortened.

Model **RCM-101-MW** (External device communication cable + RS232 conversion unit)

Setting

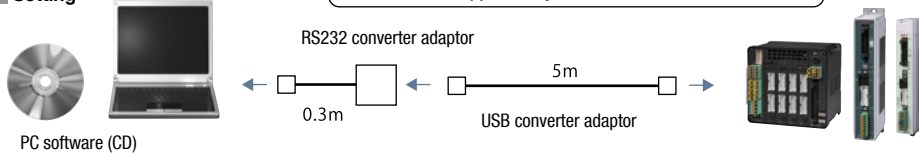

Supported Windows: 2000 SP4 or later / XP SP2 or later / Vista / 7



Model **RCM-101-USB** (External device communication cable + USB converter adaptor + USB cable)

Setting

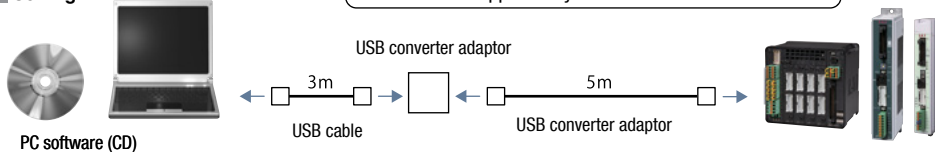

External regeneration resistor

Summary The regeneration resistor converts regenerated current dissipated during deceleration of the motor load into heat. The MSEP controller has an internal regeneration resistor for ordinary operations, however, depending on the operational condition, please install an external regeneration resistor if the internal regeneration resistor capacity is insufficient.

Model **RER-1**

Exterior dimensions

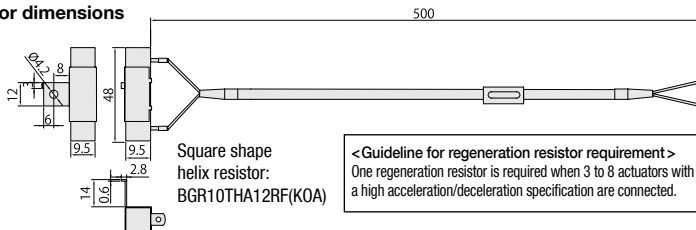

Driver board

Summary A supplement or modification to the driver board is feasible with the MSEP controller. When the actuator that control motions needs to be modified, just replacing the driver board would serve the purpose without changing the entire controller. (The parameters need to be adjusted when changing the driver board)

Model / Standard price

Motor type	High output type	Encoder type	Number of axes	Model	Standard price
Pulse motor	High output setting	Battery-less absolute/incremental	1-axis	MSEP-PPD1-W	—
		Simple absolute	1-axis	MSEP-PPD1-A	—
	Cancellation of high output setting	Battery-less absolute/incremental	1-axis	MSEP-PD1-W	—
		Simple absolute	2-axis	MSEP-PD2-W	—
AC servo motor	—	Incremental	1-axis	MSEP-AD1-I	—
			2-axis	MSEP-AD2-I	—
	—	Simple absolute	1-axis	MSEP-AD1-A	—
			2-axis	MSEP-AD2-A	—
DC servo motor	—	Incremental	1-axis	MSEP-DD1-I	—
			2-axis	MSEP-DD2-I	—

Box for the absolute data backup battery

Summary If the absolute position encoder specification is selected with code ABB, the absolute data backup battery box is included with the controller. However, if the battery box is ordered as a separate unit, it does not include the battery but just the box itself. If the battery is needed, please purchase it separately. (Model: AB-7).

Model **MSEP-ABB** (Batteries not included)

Exterior dimensions See P.55

* A cable (Model CB-MSEP-AB005) that connects the absolute data backup battery box to the MSEP is included with the box.

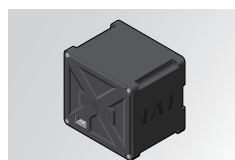

Replacement battery

Summary The replacement battery for the absolute data backup battery box.

Model **AB-7**

Replacement fan unit

Model **MSEP-FU**



Service parts

Model number	CB-CAN-MPA <input type="checkbox"/> <input type="checkbox"/> <input type="checkbox"/>	Integrated Motor-Encoder Cable	for RCP5/RCD
	CB-CAN-MPA <input type="checkbox"/> <input type="checkbox"/> <input type="checkbox"/> -RB	Integrated Motor-Encoder Robot Cable	

* Please indicate cable length (L) in , maximum 20m. e.g.) 080=8m

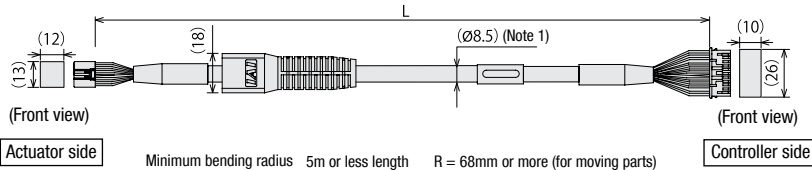

Minimum bending radius 5m or less length R = 68mm or more (for moving parts)
Longer than 5m R = 73mm or more (for moving parts)

* The robot cable is designed for flex-resistance: Please use the robot cable if the cable has to be installed through the cable track.

(Note 1) If the cable is 5m or longer, Ø9.1 cable diameter applies for a non-robot cable and Ø10 for a robot cable.

Pin No	Signal name	Pin No	Signal name
3	ØA	1	2A
5	VMM	2	VMM
10	ØB	3	ØB
9	VMM	4	VMM
4	Ø A	5	Ø A
15	Ø B	6	Ø B
8	LS+	7	LS+
14	LS-	8	LS-
12	SA(mABS)	11	SA(mABS)
17	SB(mABS)	12	SB(mABS)
1	A+	13	A+
6	A-	14	A-
11	B+	15	B+
16	B-	16	B-
20	BK+	9	BK+
2	BK-	10	BK-
21	VCC	17	VCC
7	GND	19	GND
18	VPS	18	VPS
13	LS_GND	20	LS_GND
19	---	22	---
22	-(CFVCC)	21	-(CFVCC)
23	---	23	---
24	FG	24	FG

Model number	CB-CFA3-MPA <input type="checkbox"/> <input type="checkbox"/> <input type="checkbox"/>	Integrated Motor-Encoder Cable	for RCP5-RA8C/8R/10C/10R
	CB-CFA3-MPA <input type="checkbox"/> <input type="checkbox"/> <input type="checkbox"/> -RB	Integrated Motor-Encoder Robot Cable	

* Please indicate cable length (L) in , maximum 20m. e.g.) 080=8m

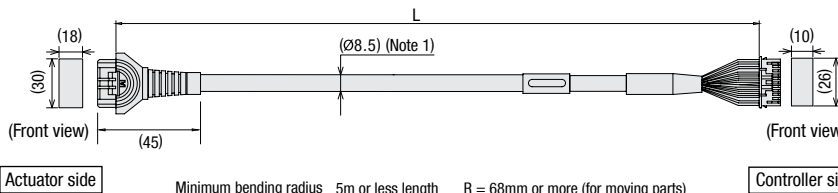

Minimum bending radius 5m or less length R = 68mm or more (for moving parts)
Longer than 5m R = 73mm or more (for moving parts)

* The robot cable is designed for flex-resistance: Please use the robot cable if the cable has to be installed through the cable track.

(Note 1) If the cable is 5m or longer, Ø9.1 cable diameter applies for a non-robot cable and Ø10 for a robot cable.

Pin No	Signal name	Pin No	Signal name
A1	Ø A	1	Ø A
B1	VMM	5	VMM
A2	Ø A	5	Ø A
B2	Ø B	3	Ø B
A3	VMM	4	VMM
B3	Ø B	6	Ø B
A4	LS+	7	LS+
B4	LS-	8	LS-
A6	SA(mABS)	11	SA(mABS)
B6	SB(mABS)	12	SB(mABS)
A7	A+	13	A+
B7	A-	14	A-
A8	B+	15	B+
B8	B-	16	B-
A5	BK+	9	BK+
B5	BK-	10	BK-
A9	LS_GND	20	LS_GND
B9	VPS	18	VPS
A10	VCC	17	VCC
B10	GND	19	GND
A11	---	21	---
B11	FG	24	FG

Model number	CB-CA-MPA <input type="checkbox"/> <input type="checkbox"/> <input type="checkbox"/>	Integrated Motor-Encoder Cable	for RCP4
	CB-CA-MPA <input type="checkbox"/> <input type="checkbox"/> <input type="checkbox"/> -RB	Integrated Motor-Encoder Robot Cable	

* Please indicate cable length (L) in , maximum 20m. e.g.) 080=8m

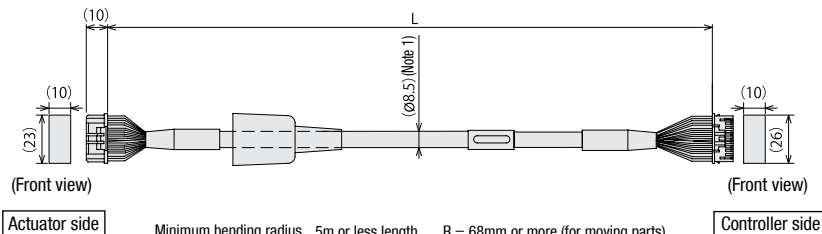

Minimum bending radius 5m or less length R = 68mm or more (for moving parts)
Longer than 5m R = 73mm or more (for moving parts)

* The robot cable is designed for flex-resistance: Please use the robot cable if the cable has to be installed through the cable track.

(Note 1) If the cable is 5m or longer, Ø9.1 cable diameter applies for a non-robot cable and Ø10 for a robot cable.

Pin No	Signal name	Pin No	Signal name
A1	ØA/U	1	ØA/U
B1	VMM/V	5	VMM/V
A2	ØA/W	5	ØA/W
B2	ØB/-	3	ØB/-
A3	VMM/-	4	VMM/-
B3	ØB/-	6	ØB/-
A4	LS+/BK+	7	LS+/BK+
B4	LS-/BK-	8	LS-/BK-
A6	-/A+	11	-/A+
B6	-/A-	12	-/A-
A7	A+/B+	13	A+/B+
B7	A-/B-	14	A-/B-
A8	B+/Z+	15	B+/Z+
B8	B-/Z-	16	B-/Z-
A5	BK+/LS+	9	BK+/LS+
B5	BK-/LS-	10	BK-/LS-
A9	LS_GND	20	LS_GND
B9	VPS	18	VPS
A10	VCC	17	VCC
B10	GND	19	GND
A11	---	21	---
B11	FG	24	FG

Model number	CB-APSEP-MPA <input type="checkbox"/> <input type="checkbox"/> <input type="checkbox"/> -LC	Integrated Motor-Encoder Cable	for RCP3/RCA2 and others
	CB-APSEP-MPA <input type="checkbox"/> <input type="checkbox"/> <input type="checkbox"/>	Integrated Motor-Encoder Robot Cable	

* Please indicate cable length (L) in , maximum 20m. e.g.) 080=8m

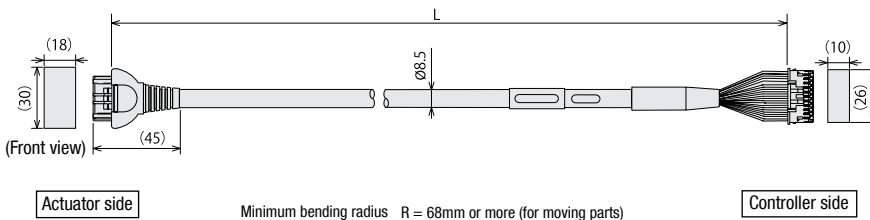

Minimum bending radius R = 68mm or more (for moving parts)

* The robot cable is designed for flex-resistance: Please use the robot cable if the cable has to be installed through the cable track.

Actuator side	Pin number	Controller side	Pin number
A1	(ØA) (U)	1	
B1	(VMM) (V)	2	
A2	(ØA) (W)	5	
B2	(ØB) (-)	3	
A3	(VMM) (-)	4	
B3	(ØB) (-)	6	
A4	(LS+) (BK+)	7	
B4	(LS-) (BK-)	8	
A6	(-) (A+)	11	
B6	(-) (A-)	12	
A7	(A+) (B+)	13	
B7	(A-) (B-)	14	
A8	(B+) (Z+)	15	
B8	(B-) (Z-)	16	
A5	(BK+) (LS+)	9	
B5	(BK-) (LS-)	10	
A9	(GND) (LS)	20	
B9	(VPS) (VPS)	18	
A10	(VCC) (VCC)	17	
B10	(GND) (GND)	19	
A11	NC	21	
B11	Shield (FG) (FG)	24	
	NC	22	
		23	

Model number **CB-PSEP-MPA** **Integrated Motor-Encoder Robot Cable** **for RCP2**

* Please indicate cable length (L) in , maximum 20m. e.g.) 080=8m

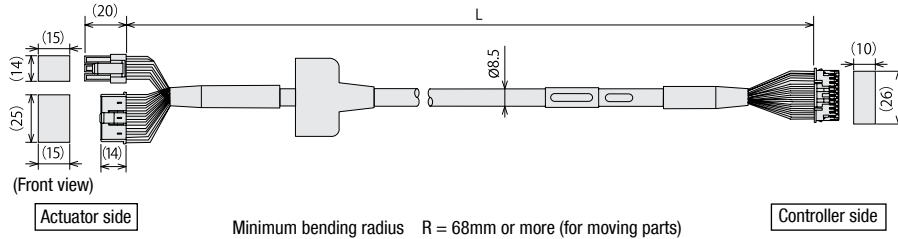

Actuator side Pin number		Controller side Pin number
1		1
2	[ΦA]	2
4	[VMM]	3
5	[ΦB]	4
3	[VMM]	5
6	[Φ/A]	6
16	[Φ/B]	9
17	[BK+]	10
6	[BK-]	11
5	NC	12
13	[LS+]	7
14	[LS-]	8
1	[A+]	13
2	[A-]	14
3	[B+]	15
4	[B-]	16
10	[VCC]	17
11	[VPS]	18
9	[GND]	19
12	[Spare]	20
15	NC	21
7	NC	22
8	NC	23
18	Shield [FG]	24

Model number **CB-RPSEP-MPA** **Integrated Motor-Encoder Robot Cable** **for RCP2-RTBS/RTBSL/RTCS/RTCSL**

* Please indicate cable length (L) in , maximum 20m. e.g.) 080=8m

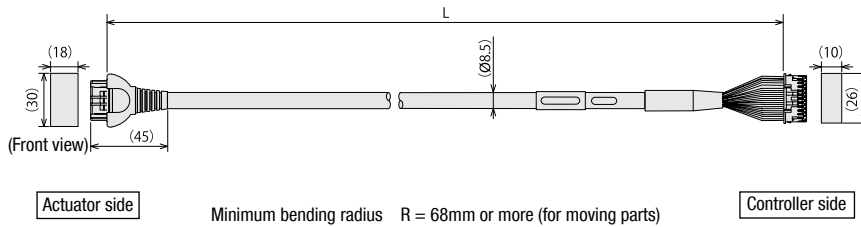

Actuator side Pin number		Controller side Pin number
A1		1
B1	[ΦA]	2
A2	[VMM]	5
B2	[Φ/B]	3
A3	[VMM]	4
B3	[Φ/A]	6
A6	[Φ/B]	7
B6	[LS+]	8
A7	[A+]	13
B7	[A-]	14
A8	[B+]	15
B8	[B-]	16
A4	NC	—
B4	NC	—
A5	[BK+]	9
B5	[BK-]	10
A9	[GND/S]	20
B9	[VPS]	18
A10	[VCC]	17
B10	[GND]	19
A11	NC	21
B11	Shield [FG] (FG)	24
	NC	22
	NC	23

Model number **CB-ASEP-MPA** **Integrated Motor-Encoder Robot Cable** **for RCA**

* Please indicate cable length (L) in , maximum 20m. e.g.) 080=8m

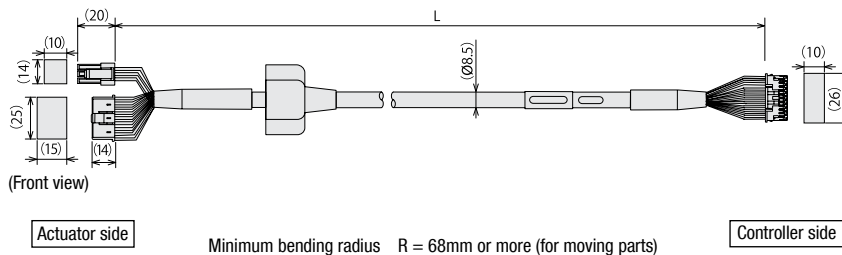

Actuator side Pin number		Controller side Pin number
1	[U]	1
2	[V]	2
	NC	3
3	NC	4
	[W]	5
	NC	6
18	[BK+]	7
17	[BK-]	8
7	[LS+]	9
16	[LS-]	10
1	[A+]	11
2	[A-]	12
3	[B+]	13
4	[B-]	14
10	[VCC]	15
11	[VPS]	16
14	[GND]	17
13	[VPS]	18
15	[GND]	19
6	[Spare]	20
5	NC	21
8	NC	22
12	NC	23
9	Shield [FG]	24

Model number **CB-MSEP-PIO** **PIO Flat Cable** **for MSEP-C**

* Please indicate cable length (L) in , maximum 10m. e.g.) 020=2m

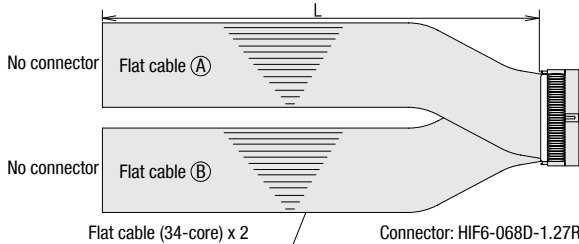

HIF6-068D-1.27R

No.	Cable color	Wiring
A1	Brown-1	
A2	Red-1	
A3	Orange-1	
A4	Yellow-1	
A5	Green-1	
A6	Blue-1	
A7	Purple-1	
A8	Gray-1	
A9	White-1	
A10	Black-1	
A11	Brown-2	
A12	Red-2	
A13	Orange-2	
A14	Yellow-2	
A15	Green-2	
A16	Blue-2	
A17	Purple-2	

No.	Cable color	Wiring
A18	Gray-2	
A19	White-2	
A20	Black-2	
A21	Brown-3	
A22	Red-3	
A23	Orange-3	
A24	Yellow-3	
A25	Green-3	
A26	Blue-3	
A27	Purple-3	
A28	Gray-3	
A29	White-3	
A30	Black-3	
A31	Brown-4	
A32	Red-4	
A33	Orange-4	
A34	Yellow-4	

No.	Cable color	Wiring
B1	Brown-5	
B2	Red-5	
B3	Orange-5	
B4	Yellow-5	
B5	Green-5	
B6	Blue-5	
B7	Purple-5	
B8	Gray-5	
B9	White-5	
B10	Black-5	
B11	Brown-6	
B12	Red-6	
B13	Orange-6	
B14	Yellow-6	
B15	Green-6	
B16	Blue-6	
B17	Purple-6	

No.	Cable color	Wiring
B18	Gray-6	
B19	White-6	
B20	Black-6	
B21	Brown-7	
B22	Red-7	
B23	Orange-7	
B24	Yellow-7	
B25	Green-7	
B26	Blue-7	
B27	Purple-7	
B28	Gray-7	
B29	White-7	
B30	Black-7	
B31	Brown-8	
B32	Red-8	
B33	Orange-8	
B34	Yellow-8	

Model number **CB-PAC-PIO** **PIO Flat Cable** **for PCON-CA/MSEP-LC**

* Please indicate cable length (L) in , maximum 20m. e.g.) 080=8m

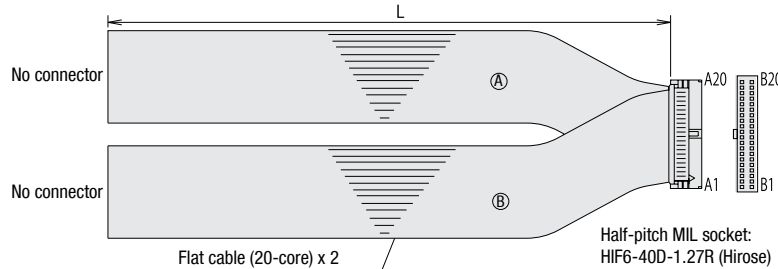

HIF6-40D-1.27R

No.	Signal name	Cable color	Wiring
A1	24V	Brown-1	
A2	24V	Red-1	
A3	—	Orange-1	
A4	—	Yellow-1	
A5	IN0	Green-1	
A6	IN1	Blue-1	
A7	IN2	Purple-1	
A8	IN3	Gray-1	
A9	IN4	White-1	
A10	IN5	Black-1	
A11	IN6	Brown-2	
A12	IN7	Red-2	
A13	IN8	Orange-2	
A14	IN9	Yellow-2	
A15	IN10	Green-2	
A16	IN11	Blue-2	
A17	IN12	Purple-2	
A18	IN13	Gray-2	
A19	IN14	White-2	
A20	IN15	Black-2	

No.	Signal name	Cable color	Wiring
B1	OUT0	Brown-3	
B2	OUT1	Red-3	
B3	OUT2	Orange-3	
B4	OUT3	Yellow-3	
B5	OUT4	Green-3	
B6	OUT5	Blue-3	
B7	OUT6	Purple-3	
B8	OUT7	Gray-3	
B9	OUT8	White-3	
B10	OUT9	Black-3	
B11	OUT10	Brown-4	
B12	OUT11	Red-4	
B13	OUT12	Orange-4	
B14	OUT13	Yellow-4	
B15	OUT14	Green-4	
B16	OUT15	Blue-4	
B17	—	Purple-4	
B18	—	Gray-4	
B19	OV	White-4	
B20	OV	Black-4	

IAI America, Inc.

Headquarters: 2690 W. 237th Street, Torrance, CA 90505 (800) 736-1712

Chicago Office: 110 E. State Pkwy, Schaumburg, IL 60195 (800) 944-0333

Atlanta Office: 1220 Kennestone Circle, Suite 108, Marietta, GA 30066 (888) 354-9470

www.intelligentactuator.com

The information contained in this product brochure may change without prior notice due to product improvements.

IAI Industrieroboter GmbH

Ober der Röth 4, D-65824 Schwalbach am Taunus, Germany

IAI Robot (Thailand), CO., Ltd.

825 PhairojKijja Tower 12th Floor, Bangna-Trad RD.,
Bangna, Bangna, Bangkok 10260, Thailand

