



ROBO Cylinder RCP6/RCP6S/RCP6CR/RCP6SCR Actuator Slider Type Instruction Manual

══════════════════ **Second edition** ══════════════════

Motor Straight Type: RCP6/RCP6S-SA4C、SA6C、SA7C、SA8C
Side-Mounted Motor Type: RCP6/RCP6S-SA4R、SA6R、SA7R、SA8R

Cleanroom Type: RCP6CR/RCP6SCR- SA4C、SA6C、SA7C、
Motor Straight Type: SA8C

Please Read Before Use

Thank you for purchasing our product.

This instruction manual explains the handling methods, structure and maintenance of this product, among others, providing the information you need to know to use the product safely.

Before using the product, be sure to read this manual and fully understand the contents explained herein to ensure safe use of the product.

The DVD that comes with the product contains instruction manuals for IAI products.

When using the product, refer to the necessary portions of the applicable instruction manual by printing them out or displaying them on a PC.

After reading the instruction manual, keep it in a convenient place so that whoever is handling this product can reference it quickly when necessary.

[Important]

- This instruction manual is original.
- This product is not to be used for any other purpose from what is noted in this instruction manual. IAI shall not be liable whatsoever for any loss or damage arising from the result of using the product for any other purpose from what is noted in the manual.
- The information contained in this instruction manual is subject to change without notice for the purpose of production improvement.
- If you have any question or finding regarding the information contained in this instruction manual, contact our customer center or our sales office near you.
- Using or copying all or a part of this instruction manual without permission is prohibited.
- The company names, names of products and trademarks of each company shown in the sentences are registered trademarks.

RC ROBO CYLINDER

Table of Contents

Safety Guide	1
Caution in Handling	9
International Standards Compliances	10
Names of the Parts.....	11
1. Specifications Check	18
1.1 Checking the Product	18
1.1.1 Parts.....	18
1.1.2 Related Instruction Manuals for the Each Controller Supported by This Product	18
1.1.3 How to Read the Model Nameplate.....	18
1.1.4 How to Read the Model Number	19
1.2 Specifications	21
1.2.1 Speed.....	21
1.2.2 Maximum Speed and Payload of the Single Slider	25
1.2.3 Maximum Speed and Payload of the Double Slider Specification (Option)	53
1.2.4 Driving System • Position Detector.....	68
1.2.5 Positioning Precision	69
1.2.6 Current Limit Value and Pressing Force.....	70
1.2.7 Allowable Moment of Actuator	74
1.2.8 Duty ratio for continuous operation.....	76
1.3 Options	77
1.3.1 Brake Type (Model : B).....	77
1.3.2 Reversed-home Specification (Model : NM).....	77
1.3.3 High Precision Specifications (Model: HPR)	77
1.3.4 Motor Left Side-Mounted, Motor Right Side-Mounted (Model: ML, MR).....	77
1.3.5 Cable Exit Direction Changed (Model: CJT, CJR, CJL, CJB, CJO)	78
1.3.6 Slider spacer (Model: SS).....	78
1.3.7 Slider Roller Specification (Model: SR)	78
1.3.8 Double Slider Specification (Model: W)	78
1.3.9 Air Vacuum Joint on the Opposite Side (Model: VR).....	78
1.4 Motor • Encoder Cables.....	79
1.4.1 Motor • Encoder Integrated Cables (SA4, SA6 and SA7)	79
1.4.2 Motor • Encoder Integrated Cables Robot Type (SA4, SA6 and SA7).....	80
1.4.3 Motor • Encoder Integrated Cables (SA8)	81
1.4.4 Motor • Encoder Integrated Cables Robot Type (SA8).....	82
2. Installation	84
2.1 Transportation.....	84
2.2 Installation and Storage • Preservation Environment	86
2.3 How to Install.....	87
2.3.1 Installation.....	87
2.3.2 Installation of the Main Unit	88
2.3.3 About Suction of the CleanroomType.....	98
3. Connecting with the Controller	99
4. Maintenance and Inspection	103

4.1	Inspection Items and Schedule	103
4.2	External Visual Inspection.....	104
4.3	Cleaning	104
4.4	Internal Inspections	105
4.5	Internal Cleaning	105
4.6	Grease Supply.....	106
4.6.1	Standard Type Grease to Use	106
4.6.2	How to Apply Grease	107
4.7	Procedure for Stainless Steel Sheet Replacement and Adjustment.....	110
4.7.1	Preparation	110
4.7.2	Procedure for Replacement and Tuning.....	111
4.8	Procedure for Belt Replacement and Tuning	116
4.8.1	Inspection of the Belt	116
4.8.2	Belt to Use	116
4.8.3	Belt Replacement	117
4.9	Motor Replacement Process.....	122
4.9.1	SA4C, SA6C, SA7C, SA8C	122
4.9.2	SA4R, SA6R, SA7R, SA8R	124
5.	External Dimensions	131
5.1	Standard Specification RCP6-SA4C	131
5.2	Built-in Controller Specification RCP6S-SA4C	132
5.3	Standard Specification RCP6-SA6C	133
5.4	Built-in Controller Specification RCP6S-SA6C	134
5.5	Standard Specification RCP6-SA7C	135
5.6	Built-in Controller Specification RCP6S-SA7C	136
5.7	Standard Specification RCP6-SA8C	137
5.8	Built-in Controller Specification RCP6S-SA8C	138
5.9	Standard Specification RCP6-SA4R Left Side-Mounted (Model: ML)	139
5.10	Built-in Controller Specification RCP6S-SA4R Left Side-Mounted (Model: ML)	140
5.11	Standard Specification RCP6-SA6R Left Side-Mounted (Model: ML)	141
5.12	Built-in Controller Specification RCP6S-SA6R Left Side-Mounted (Model: ML)	142
5.13	Standard Specification RCP6-SA7R Left Side-Mounted (Model: ML)	143
5.14	Built-in Controller Specification RCP6S-SA7R Left Side-Mounted (Model: ML)	144
5.15	Standard Specification RCP6-SA8R Left Side-Mounted (Model: ML)	146
5.16	Built-in Controller Specification RCP6S-SA8R Left Side-Mounted (Model: ML)	147
5.17	Cleanroom Type Standard Specification RCP6CR-SA4C.....	149
5.18	Cleanroom Type Built-in Controller Specification RCP6SCR-SA4C	150
5.19	Cleanroom Type Standard Specification RCP6CR-SA6C.....	151
5.20	Cleanroom Type Built-in Controller RCP6SCR-SA6C	152
5.21	Cleanroom Standard Specification RCP6CR-SA7C	153

5.22	Cleanroom Type Built-in Controller Specification RCP6SCR-SA7C	154
5.23	Cleanroom Type Standard Specification RCP6CR-SA8C.....	155
5.24	Cleanroom Type Built-in Controller Specification RCP6SCR-SA8C	156
5.25	Standard Specification Double Slider Specification RCP6-SA4C (Option Model W)	157
5.26	Standard Specification Double Slider Specification RCP6-SA6C (Option Model W)	158
5.27	Standard Specification Double Slider Specification RCP6-SA7C (Option Model W)	159
5.28	Standard Specification Double Slider Specification RCP6-SA8C (Option Model W)	160
6.	Life	165
6.1	How to Calculate Operation Life	165
6.2	Operation Life	166
7.	Warranty	167
7.1	Warranty Period.....	167
7.2	Scope of the Warranty	167
7.3	Honoring the Warranty.....	167
7.4	Limited Liability	168
7.5	Conditions of Conformance with Applicable Standards/Regulations, Etc., and Applications	168
7.6	Other Items Excluded from Warranty	168
	Change History.....	169

Safety Guide

“Safety Guide” has been written to use the machine safely and so prevent personal injury or property damage beforehand. Make sure to read it before the operation of this product.

Safety Precautions for Our Products

The common safety precautions for the use of any of our robots in each operation.

No.	Operation Description	Description
1	Model Selection	<ul style="list-style-type: none"> • This product has not been planned and designed for the application where high level of safety is required, so the guarantee of the protection of human life is impossible. Accordingly, do not use it in any of the following applications. <ol style="list-style-type: none"> 1) Medical equipment used to maintain, control or otherwise affect human life or physical health. 2) Mechanisms and machinery designed for the purpose of moving or transporting people (For vehicle, railway facility or air navigation facility) 3) Important safety parts of machinery (Safety device, etc.) • Do not use the product outside the specifications. Failure to do so may considerably shorten the life of the product. • Do not use it in any of the following environments. <ol style="list-style-type: none"> 1) Location where there is any inflammable gas, inflammable object or explosive 2) Place with potential exposure to radiation 3) Location with the ambient temperature or relative humidity exceeding the specification range 4) Location where radiant heat is added from direct sunlight or other large heat source 5) Location where condensation occurs due to abrupt temperature changes 6) Location where there is any corrosive gas (sulfuric acid or hydrochloric acid) 7) Location exposed to significant amount of dust, salt or iron powder 8) Location subject to direct vibration or impact • For an actuator used in vertical orientation, select a model which is equipped with a brake. If selecting a model with no brake, the moving part may drop when the power is turned OFF and may cause an accident such as an injury or damage on the work piece.

No.	Operation Description	Description
2	Transportation	<ul style="list-style-type: none"> ● When carrying a heavy object, do the work with two or more persons or utilize equipment such as crane. ● When the work is carried out with 2 or more persons, make it clear who is to be the leader and who to be the follower(s) and communicate well with each other to ensure the safety of the workers. ● When in transportation, consider well about the positions to hold, weight and weight balance and pay special attention to the carried object so it would not get hit or dropped. ● Transport it using an appropriate transportation measure. The actuators available for transportation with a crane have eyebolts attached or there are tapped holes to attach bolts. Follow the instructions in the instruction manual for each model. ● Do not step or sit on the package. ● Do not put any heavy thing that can deform the package, on it. ● When using a crane capable of 1t or more of weight, have an operator who has qualifications for crane operation and sling work. ● When using a crane or equivalent equipments, make sure not to hang a load that weighs more than the equipment's capability limit. ● Use a hook that is suitable for the load. Consider the safety factor of the hook in such factors as shear strength. ● Do not get on the load that is hung on a crane. ● Do not leave a load hung up with a crane. ● Do not stand under the load that is hung up with a crane.
3	Storage and Preservation	<ul style="list-style-type: none"> ● The storage and preservation environment conforms to the installation environment. However, especially give consideration to the prevention of condensation. ● Store the products with a consideration not to fall them over or drop due to an act of God such as earthquake.

No.	Operation Description	Description
4	Installation and Start	<p>(1) Installation of Robot Main Body and Controller, etc.</p> <ul style="list-style-type: none"> ● Make sure to securely hold and fix the product (including the work part). A fall, drop or abnormal motion of the product may cause a damage or injury. Also, be equipped for a fall-over or drop due to an act of God such as earthquake. ● Do not get on or put anything on the product. Failure to do so may cause an accidental fall, injury or damage to the product due to a drop of anything, malfunction of the product, performance degradation, or shortening of its life. ● When using the product in any of the places specified below, provide a sufficient shield. <ol style="list-style-type: none"> 1) Location where electric noise is generated 2) Location where high electrical or magnetic field is present 3) Location with the mains or power lines passing nearby 4) Location where the product may come in contact with water, oil or chemical droplets <p>(2) Cable Wiring</p> <ul style="list-style-type: none"> ● Use our company's genuine cables for connecting between the actuator and controller, and for the teaching tool. ● Do not scratch on the cable. Do not bend it forcibly. Do not pull it. Do not coil it around. Do not insert it. Do not put any heavy thing on it. Failure to do so may cause a fire, electric shock or malfunction due to leakage or continuity error. ● Perform the wiring for the product, after turning OFF the power to the unit, so that there is no wiring error. ● When the direct current power (+24V) is connected, take the great care of the directions of positive and negative poles. If the connection direction is not correct, it might cause a fire, product breakdown or malfunction. ● Connect the cable connector securely so that there is no disconnection or looseness. Failure to do so may cause a fire, electric shock or malfunction of the product. ● Never cut and/or reconnect the cables supplied with the product for the purpose of extending or shortening the cable length. Failure to do so may cause the product to malfunction or cause fire. <p>(3) Grounding</p> <ul style="list-style-type: none"> ● The grounding operation should be performed to prevent an electric shock or electrostatic charge, enhance the noise-resistance ability and control the unnecessary electromagnetic radiation. ● For the ground terminal on the AC power cable of the controller and the grounding plate in the control panel, make sure to use a twisted pair cable with wire thickness 0.5mm² (AWG20 or equivalent) or more for grounding work. For security grounding, it is necessary to select an appropriate wire thickness suitable for the load. Perform wiring that satisfies the specifications (electrical equipment technical standards). ● Perform Class D Grounding (former Class 3 Grounding with ground resistance 100Ω or below).

No.	Operation Description	Description
4	Installation and Start	<p>(4) Safety Measures</p> <ul style="list-style-type: none"> ● When the work is carried out with 2 or more persons, make it clear who is to be the leader and who to be the follower(s) and communicate well with each other to ensure the safety of the workers. ● When the product is under operation or in the ready mode, take the safety measures (such as the installation of safety and protection fence) so that nobody can enter the area within the robot's movable range. When the robot under operation is touched, it may result in death or serious injury. ● Make sure to install the emergency stop circuit so that the unit can be stopped immediately in an emergency during the unit operation. ● Take the safety measure not to start up the unit only with the power turning ON. Failure to do so may start up the machine suddenly and cause an injury or damage to the product. ● Take the safety measure not to start up the machine only with the emergency stop cancellation or recovery after the power failure. Failure to do so may result in an electric shock or injury due to unexpected power input. ● When the installation or adjustment operation is to be performed, give clear warnings such as "Under Operation; Do not turn ON the power!" etc. Sudden power input may cause an electric shock or injury. ● Take the measure so that the work part is not dropped in power failure or emergency stop. ● Wear protection gloves, goggle or safety shoes, as necessary, to secure safety. ● Do not insert a finger or object in the openings in the product. Failure to do so may cause an injury, electric shock, damage to the product or fire. ● When releasing the brake on a vertically oriented actuator, exercise precaution not to pinch your hand or damage the work parts with the actuator dropped by gravity.





No.	Operation Description	Description
5	Teaching	<ul style="list-style-type: none"> ● When the work is carried out with 2 or more persons, make it clear who is to be the leader and who to be the follower(s) and communicate well with each other to ensure the safety of the workers. ● Perform the teaching operation from outside the safety protection fence, if possible. In the case that the operation is to be performed unavoidably inside the safety protection fence, prepare the “Stipulations for the Operation” and make sure that all the workers acknowledge and understand them well. ● When the operation is to be performed inside the safety protection fence, the worker should have an emergency stop switch at hand with him so that the unit can be stopped any time in an emergency. ● When the operation is to be performed inside the safety protection fence, in addition to the workers, arrange a watchman so that the machine can be stopped any time in an emergency. Also, keep watch on the operation so that any third person can not operate the switches carelessly. ● Place a sign “Under Operation” at the position easy to see. ● When releasing the brake on a vertically oriented actuator, exercise precaution not to pinch your hand or damage the work parts with the actuator dropped by gravity. <p>* Safety protection Fence : In the case that there is no safety protection fence, the movable range should be indicated.</p>
6	Trial Operation	<ul style="list-style-type: none"> ● When the work is carried out with 2 or more persons, make it clear who is to be the leader and who to be the follower(s) and communicate well with each other to ensure the safety of the workers. ● After the teaching or programming operation, perform the check operation one step by one step and then shift to the automatic operation. ● When the check operation is to be performed inside the safety protection fence, perform the check operation using the previously specified work procedure like the teaching operation. ● Make sure to perform the programmed operation check at the safety speed. Failure to do so may result in an accident due to unexpected motion caused by a program error, etc. ● Do not touch the terminal block or any of the various setting switches in the power ON mode. Failure to do so may result in an electric shock or malfunction.

No.	Operation Description	Description
7	Automatic Operation	<ul style="list-style-type: none"> ● Check before starting the automatic operation or rebooting after operation stop that there is nobody in the safety protection fence. ● Before starting automatic operation, make sure that all peripheral equipment is in an automatic-operation-ready state and there is no alarm indication. ● Make sure to operate automatic operation start from outside of the safety protection fence. ● In the case that there is any abnormal heating, smoke, offensive smell, or abnormal noise in the product, immediately stop the machine and turn OFF the power switch. Failure to do so may result in a fire or damage to the product. ● When a power failure occurs, turn OFF the power switch. Failure to do so may cause an injury or damage to the product, due to a sudden motion of the product in the recovery operation from the power failure.
8	Maintenance and Inspection	<ul style="list-style-type: none"> ● When the work is carried out with 2 or more persons, make it clear who is to be the leader and who to be the follower(s) and communicate well with each other to ensure the safety of the workers. ● Perform the work out of the safety protection fence, if possible. In the case that the operation is to be performed unavoidably inside the safety protection fence, prepare the “Stipulations for the Operation” and make sure that all the workers acknowledge and understand them well. ● When the work is to be performed inside the safety protection fence, basically turn OFF the power switch. ● When the operation is to be performed inside the safety protection fence, the worker should have an emergency stop switch at hand with him so that the unit can be stopped any time in an emergency. ● When the operation is to be performed inside the safety protection fence, in addition to the workers, arrange a watchman so that the machine can be stopped any time in an emergency. Also, keep watch on the operation so that any third person can not operate the switches carelessly. ● Place a sign “Under Operation” at the position easy to see. ● For the grease for the guide or ball screw, use appropriate grease according to the instruction manual for each model. ● Do not perform the dielectric strength test. Failure to do so may result in a damage to the product. ● When releasing the brake on a vertically oriented actuator, exercise precaution not to pinch your hand or damage the work parts with the actuator dropped by gravity. ● The slider or rod may get misaligned OFF the stop position if the servo is turned OFF. Be careful not to get injured or damaged due to an unnecessary operation. ● Pay attention not to lose the cover or untightened screws, and make sure to put the product back to the original condition after maintenance and inspection works. Use in incomplete condition may cause damage to the product or an injury. <p>* Safety protection Fence : In the case that there is no safety protection fence, the movable range should be indicated.</p>

No.	Operation Description	Description
9	Modification and Dismantle	<ul style="list-style-type: none"> ● Do not modify, disassemble, assemble or use of maintenance parts not specified based at your own discretion.
10	Disposal	<ul style="list-style-type: none"> ● When the product becomes no longer usable or necessary, dispose of it properly as an industrial waste. ● When removing the actuator for disposal, pay attention to drop of components when detaching screws. ● Do not put the product in a fire when disposing of it. The product may burst or generate toxic gases.
11	Other	<ul style="list-style-type: none"> ● Do not come close to the product or the harnesses if you are a person who requires a support of medical devices such as a pacemaker. Doing so may affect the performance of your medical device. ● See Overseas Specifications Compliance Manual to check whether complies if necessary. ● For the handling of actuators and controllers, follow the dedicated instruction manual of each unit to ensure the safety.

Alert Indication

The safety precautions are divided into “Danger”, “Warning”, “Caution” and “Notice” according to the warning level, as follows, and described in the instruction manual for each model.

Level	Degree of Danger and Damage	Symbol
Danger	This indicates an imminently hazardous situation which, if the product is not handled correctly, will result in death or serious injury.	 Danger
Warning	This indicates a potentially hazardous situation which, if the product is not handled correctly, could result in death or serious injury.	 Warning
Caution	This indicates a potentially hazardous situation which, if the product is not handled correctly, may result in minor injury or property damage.	 Caution
Notice	This indicates lower possibility for the injury, but should be kept to use this product properly.	 Notice

Caution in Handling

- 1. Do not attempt to establish the settings for the speed and acceleration/deceleration above the allowable range.**

An operation with speed and acceleration/deceleration beyond the allowable range may cause an abnormal noise, vibration, malfunction or shortened life.
- 2. Set the allowable load moment within the allowable range.**

An operation with the load beyond the allowable load moment may cause an abnormal noise, vibration, malfunction or shortened life. If it is extreme, flaking may occur on the guide, ball screw.
- 3. Set the overhang within the allowable range.**

Attaching a load with an overhang above the allowable range may cause vibration and abnormal noise.
- 4. If back and forth operations are performed repeatedly in short distance, it may wear out the film of grease.**

Continuous back and forth operation within a distance less than 30mm may cause wear of grease. As a reference, have approximately 5 cycles of back and forth operation in a distance more than 50mm in every 5,000 to 10,000 cycles to regenerate the oil film. Keep using the actuator with the grease worn out may cause malfunction. If it is extreme, flaking may occur on the guide, ball screw.
- 5. Do not attempt to hit the slider against an abstacle with high speed.**

It may destroy the coupling.
- 6. Make sure to attach the actuator properly by following this instruction manual.**

Using the product with the actuator not being certainly retained or affixed may cause abnormal noise, vibration, malfunction or shorten the product life.
- 7. Make sure to follow the usage condition, environment and specification range of the product.**

In case it is not secured, it may cause a drop in performance or malfunction of the product.

8. For PCON-CB and MCON Controllers (with option: T), it is available to switch over the setting between effective and ineffective of the high-output setting in the parameter setting.

(In the setting at delivery, the high-output setting is set to effective.)

For MSEL Controller, the high-output setting is effective and cannot switch it over to ineffective.

[Refer to an instruction manual for each controller for details]

The performance of weight capacity at each velocity and acceleration/deceleration setting differs between the high-output setting being effective and ineffective. Refer to the applicable performance specification when the high-output setting is effective or ineffective in 1.2 Specifications.

Controller	Parameter	Remarks
PCON-CB	No.152 High-output Setting [0: Ineffective, 1: Effective]	
MCON	No.152 High-output Setting [0: Ineffective, 1: Effective]	Option T: In high-output setting, available to have high-output setting effective.

International Standards Compliances

This actuator complies with the following overseas standard.

Refer to Overseas Standard Compliance Manual (ME0287) for more detailed information.

RoHS Directive	CE Marking
○	○

Names of the Parts

In this Instruction manual, the left and right sides are indicated by looking at the actuator from the motor end, with the actuator placed horizontally, as shown in the figure below.

1. Motor Straight Type

1.1 Standard Specification RCP6-SA4C

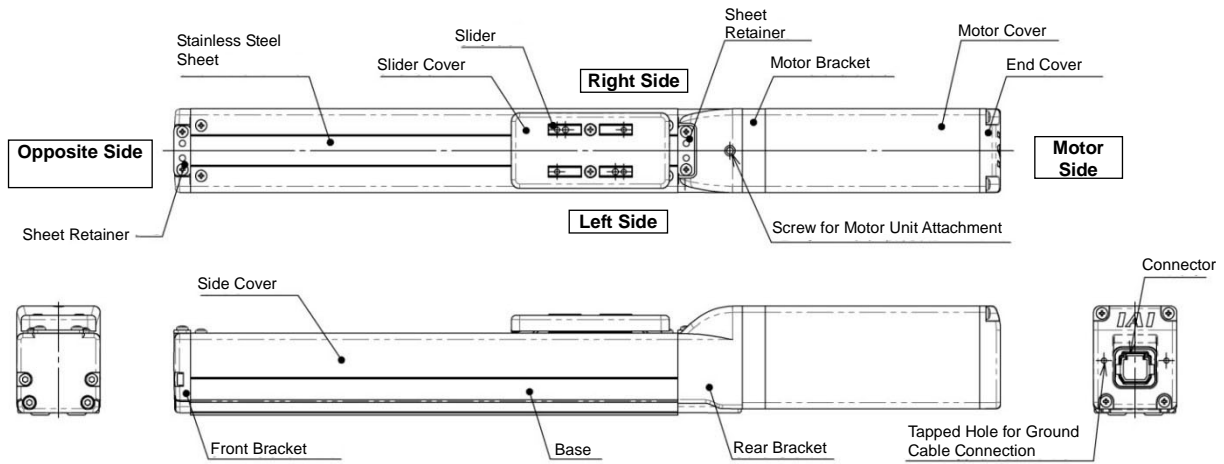

1.2 Built-in Controller Specification RCP6S-SA4C

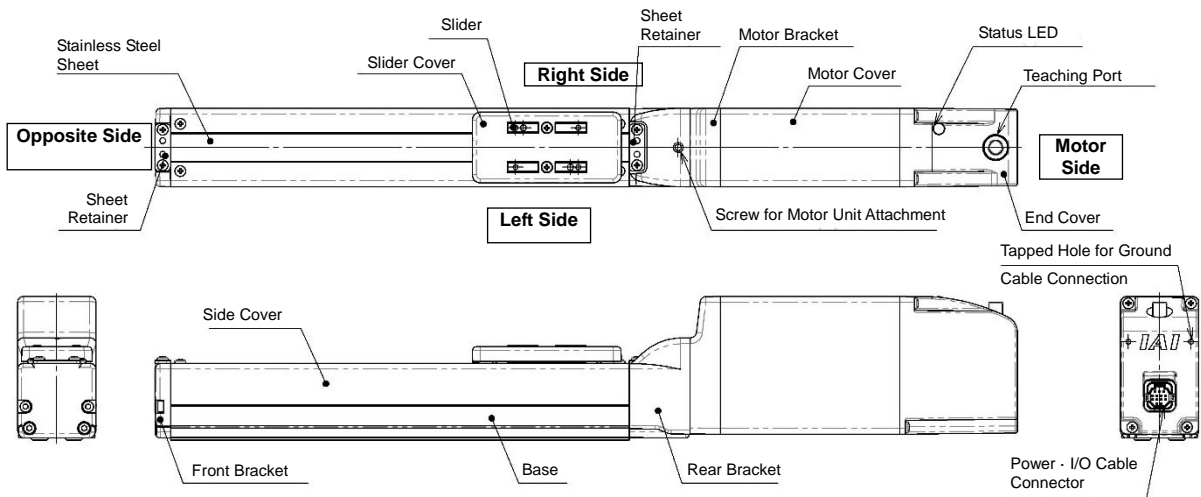

1.3 Standard Specification RCP6-SA6C, SA7C

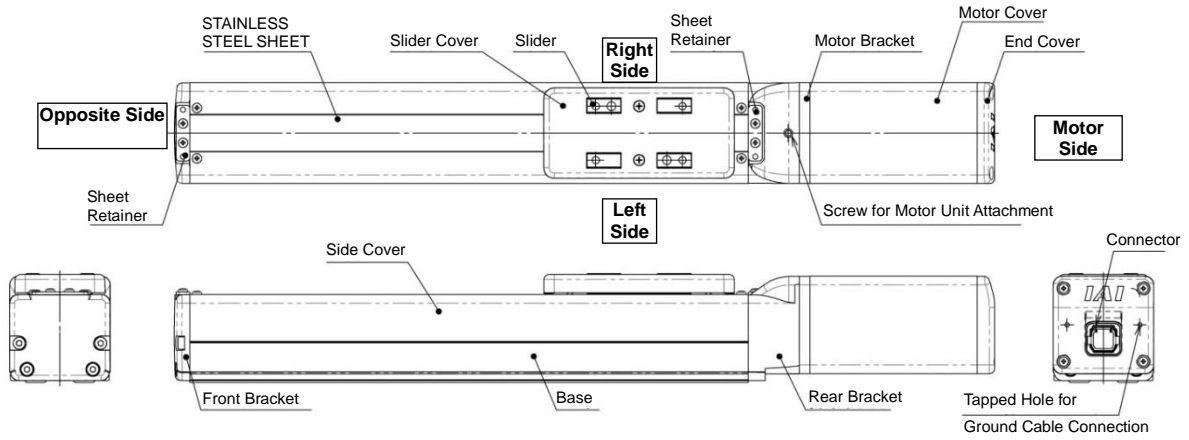

1.4 Built-in Controller Specification RCP6S-SA6C, SA7C

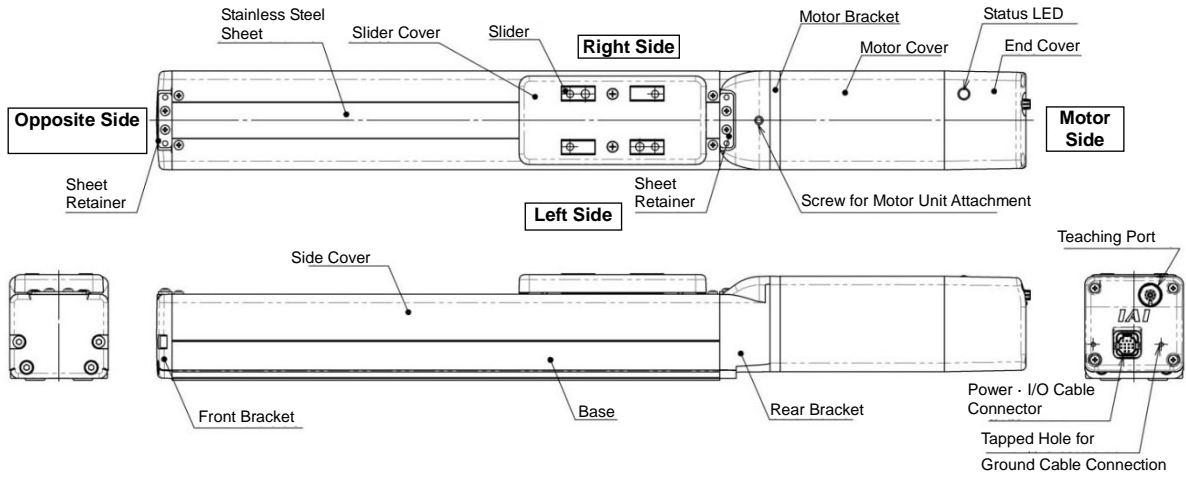

1.5 Standard Specification RCP6-SA8C

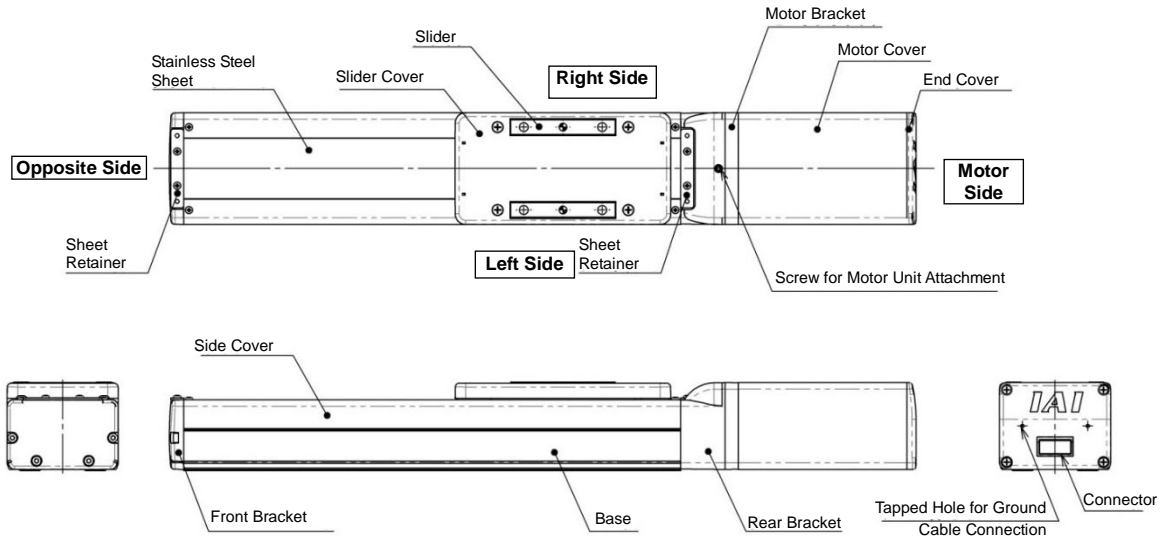

1.6 Built-in Controller Specification RCP6S-SA8C

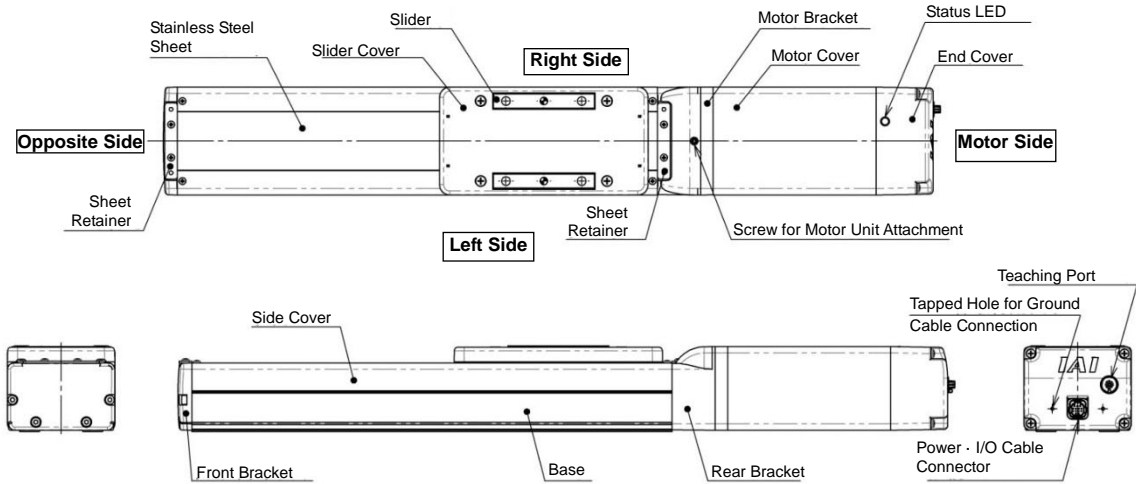

2. Side-Mounted Motor Type

2.1 Standard Specification RCP6-SA4R

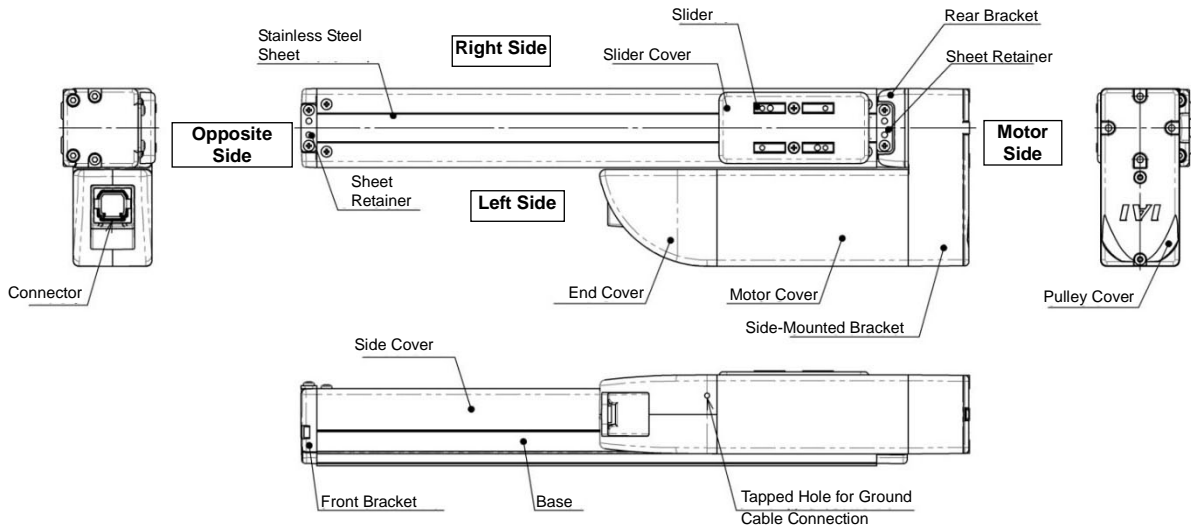

2.2 Built-in Controller Specification RCP6S-SA4R

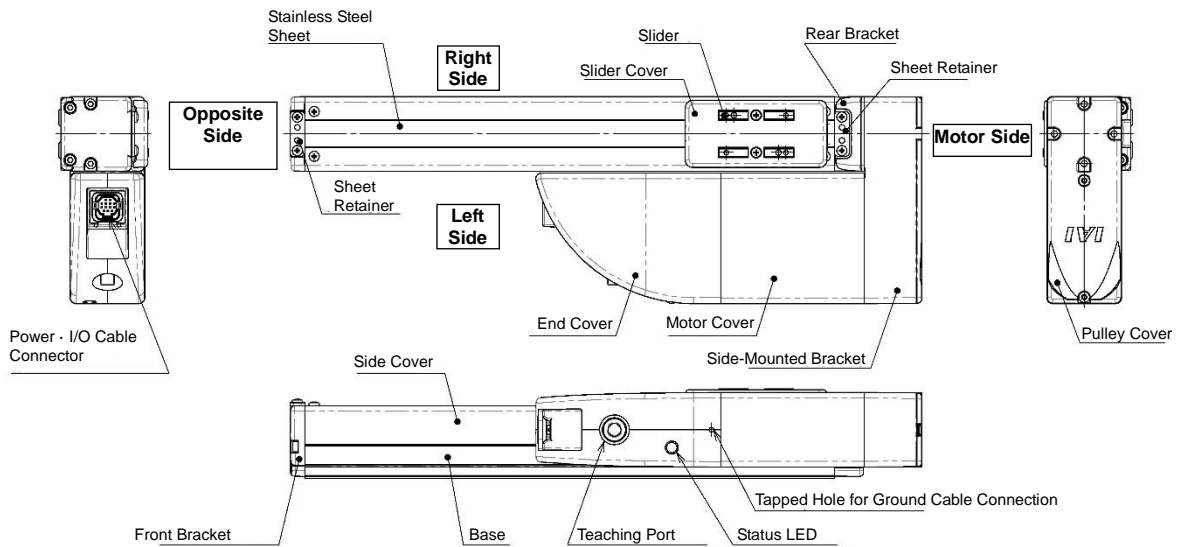

The direction of the motor is either left side-mounted: ML (shown in figure above), right side-mounted: MR.

2.3 Standard Specification RCP6-SA6R, SA7R

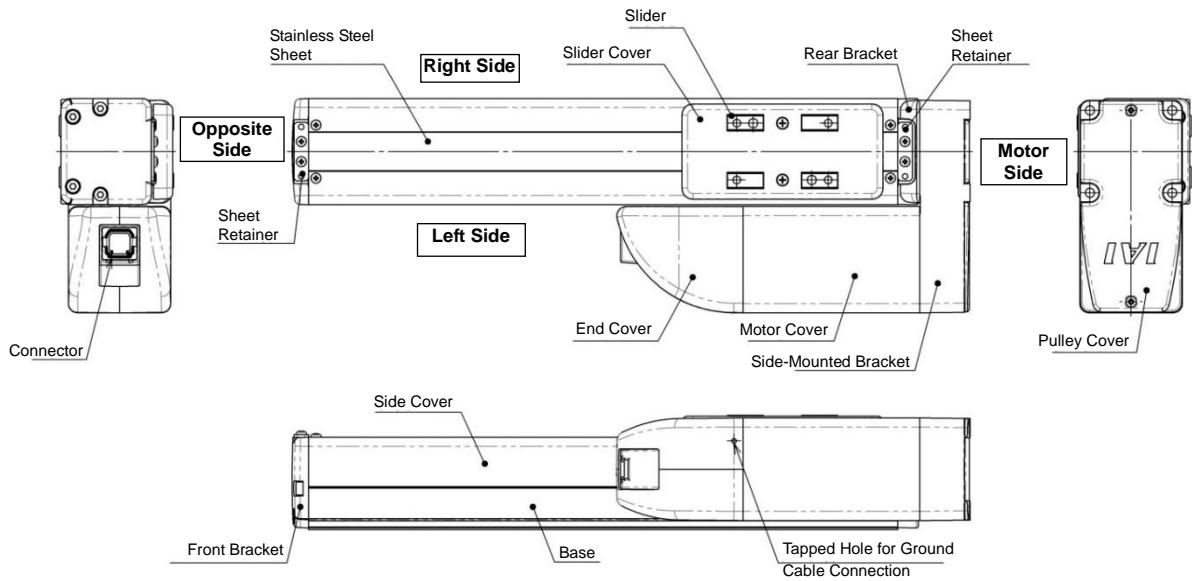

2.4 Built-in Controller Specification RCP6-SA6R, SA7R

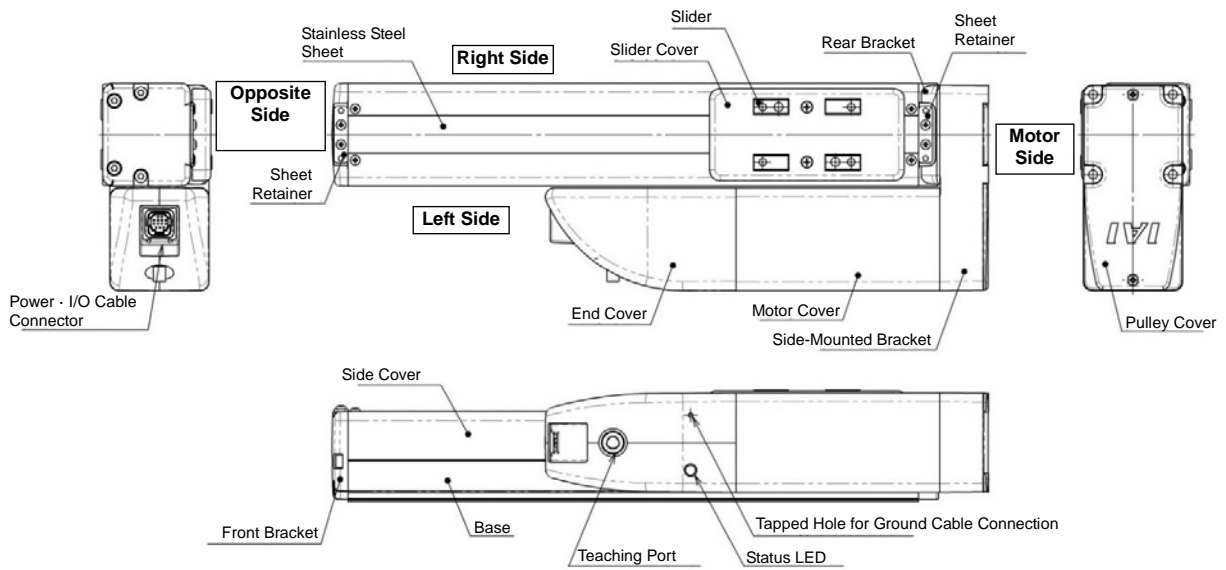

The direction of the motor is either left side-mounted: ML (shown in figure above), right side-mounted: MR.

2.5 Standard Specification RCP6-SA8R

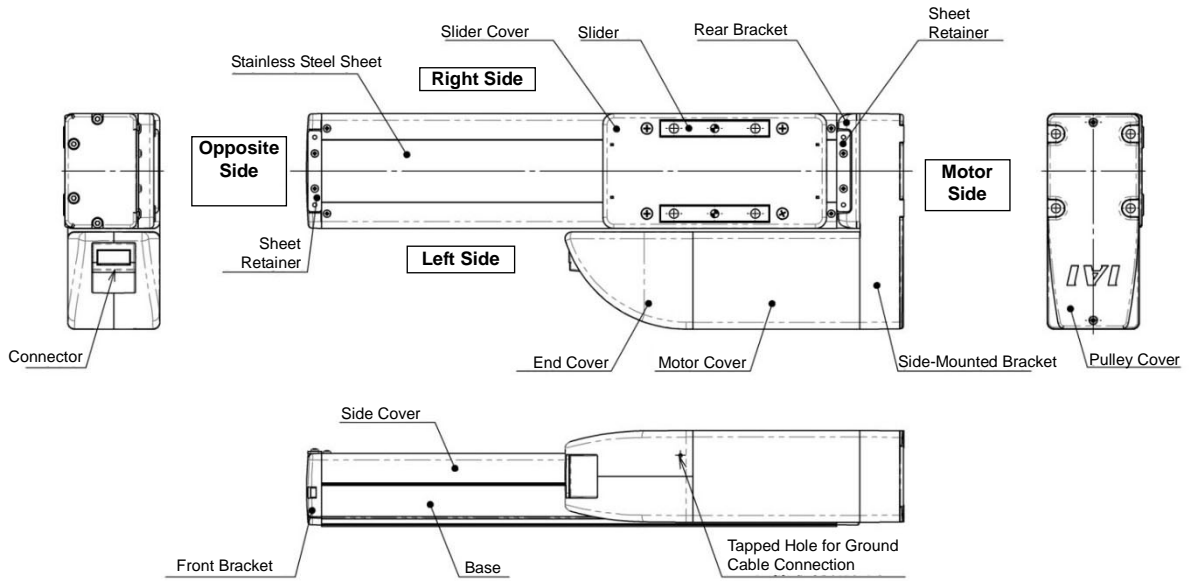

2.6 Built-in Controller Specification RCP6-SA8R

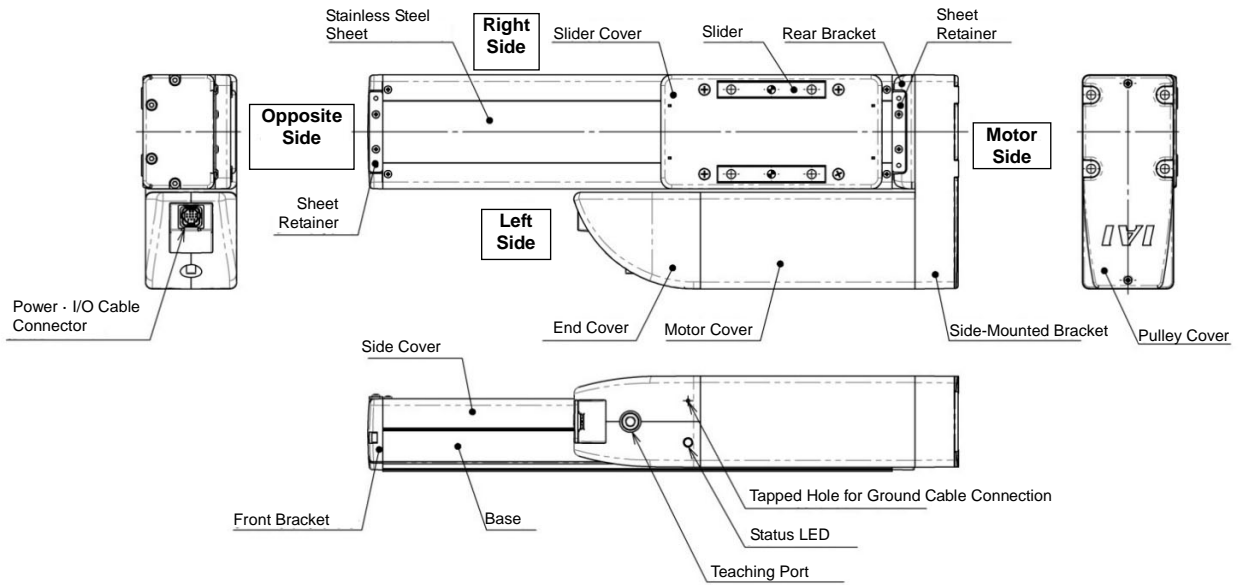

The direction of the motor is either left side-mounted: ML (shown in figure above), right side-mounted: MR.

3. Cleanroom Type

3.1 Standard Specification RCP6CR-SA4C, SA6C, SA7C, SA8C

Except for the joints, all sizes are the same as the standard sizes.

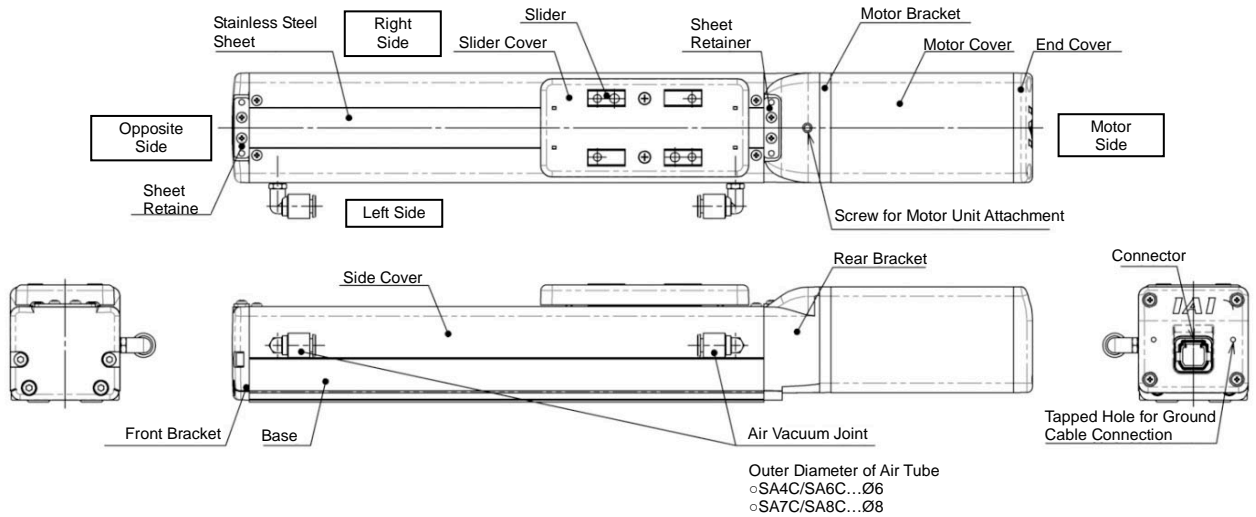

3.2 Built-in Controller Specification RCP6SCR-SA4C, SA6C, SA7C, SA8C

Except for the joints, all sizes are the same as the standard sizes.

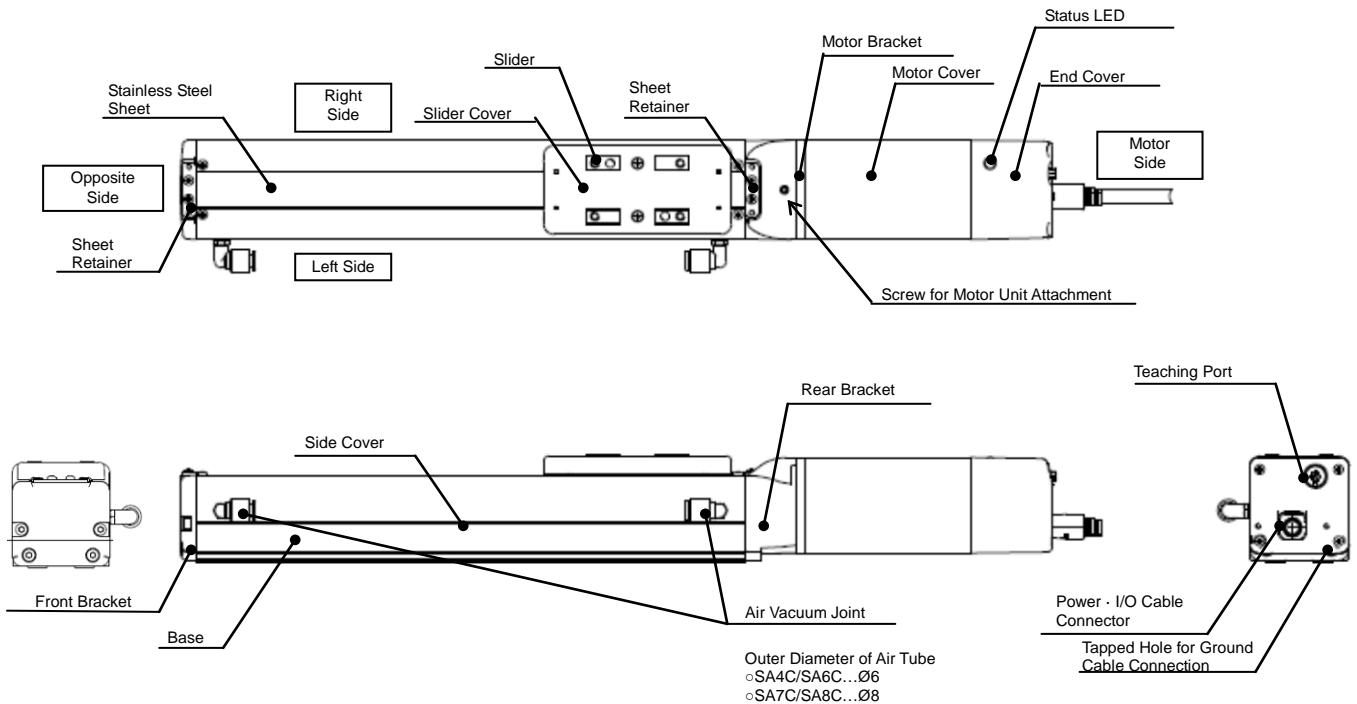

1. Specifications Check

1.1 Checking the Product

The standard configuration of this product is comprised of the following parts.

See the component list for the details of the enclosed components. If you find any fault or missing parts, contact your local IAI distributor.

1.1.1 Parts

No.	Name	Model number	Quantity	Remarks
1	Actuator	Refer to "How to Read the Model Nameplate" and "How to Read the Model Number."	1	
Accessories				
2	Motor • Encoder Cables ^(Note1)		1	
3	In-house Made Seals		1	
4	First Step Guide		1	
5	Instruction Manual (DVD)		1	
6	Safety Guide		1	

Note 1 The motor • encoder cables supplied vary depending on the controller used. [Refer to 1.4, "Motor • Encoder Cables."]

1.1.2 Related Instruction Manuals for the Each Controller Supported by This Product

Shown below is a list of the instruction manuals for the controllers related to this product which is recorded in Instruction Manual (DVD).

No.	Name	Control No.
1	Instruction Manual for PCON-CB/CFB Controller	ME0342
2	Instruction Manual for MCON-C/CG Controller	ME0341
3	Instruction Manual for MSEL Controller	ME0336
4	Instruction Manual for RC PC Software RCM-101-MW/RCM-101-USB	ME0155
5	Instruction Manual for Touch Panel Teaching Pendant CON-PTA/PDA/PGA	ME0295
6	Instruction Manual for Touch Panel Teaching Pendant TB-01/01D/01DR Applicable for Position Controller	ME0324

1.1.3 How to Read the Model Nameplate

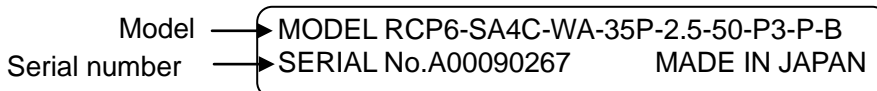

1.1.4 How to Read the Model Number

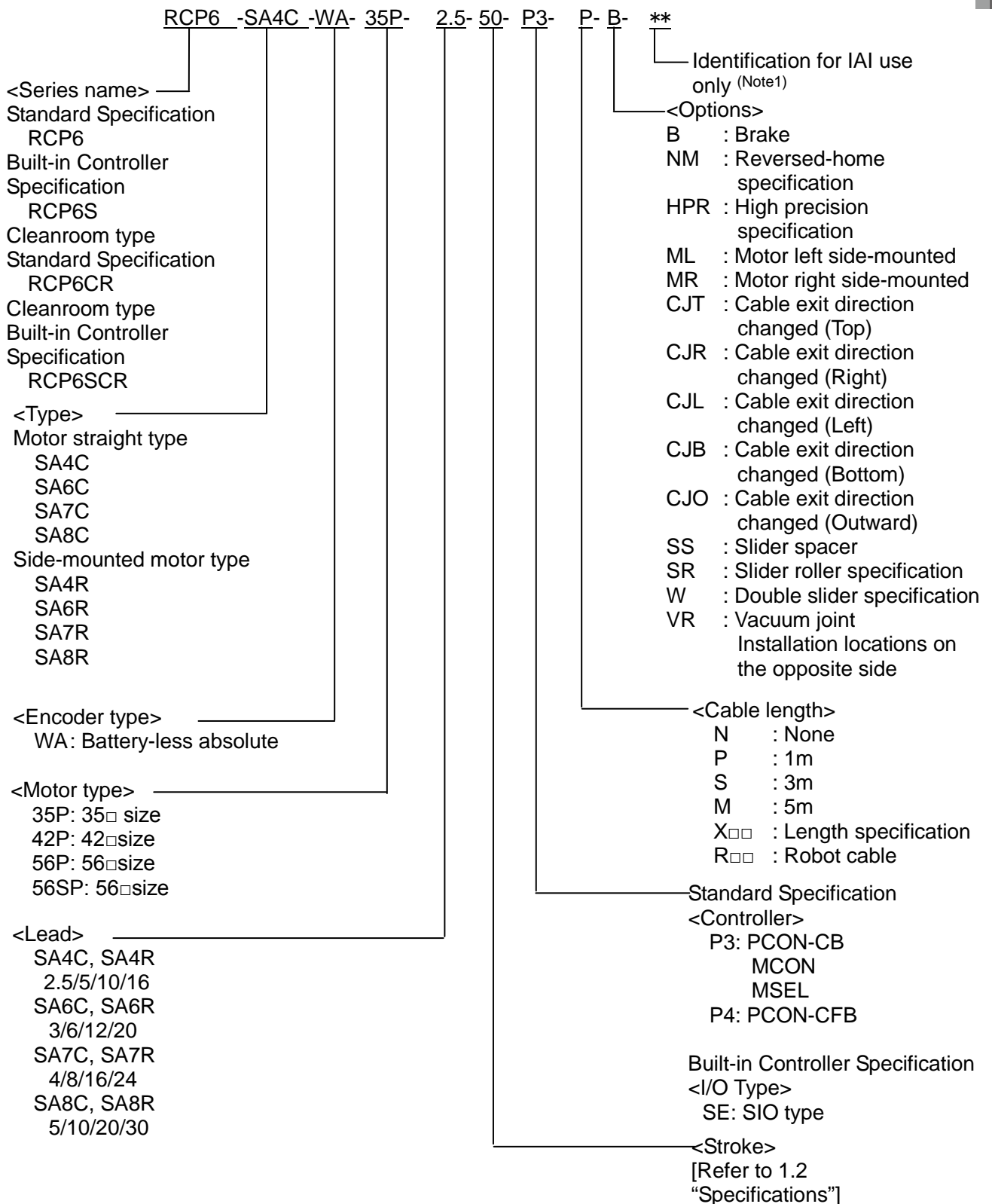

Note 1 Identification for IAI use only: It may be displayed for IAI use. It is not a code to show the model type.

- * The high precision specification HPR cannot be selected with the double slider specification W.
- * The slider spacer SS cannot be selected with the double slider specification W of the side-mounted specification.
- * The slider roller specification SR is an option of the standard specification RCP6 and the built-in controller specification RCP6S.
- * The leads described in the following table cannot be selected with the double slider specification W. Also, the vertical setting of the leads described in the following table cannot be used.

Series	Type	Double Slider Lead With No Settings	Double Slider Not Available
RCP6(S)	SA4C(S)	16	Vertical setting of lead 10
	SA6C(S)	20	Vertical setting of lead 12
	SA7C(S)	24	Vertical setting of lead 16
	SA8C(S)	30	Vertical setting of lead 20
RCP6(S)CR	SA4C	16	Vertical setting of lead 10
	SA6C	20	Vertical setting of lead 12
	SA7C	24	Vertical setting of lead 16
	SA8C	30	Vertical setting of lead 20

1.2 Specifications

1.2.1 Speed

(Note) In the case of the double slider specification, as the speed increases the payload decreases significantly more than it does in a single slider. Consequently, as the payload of the maximum speeds in the table decrease, the payload may not be appropriate for use. [Refer to 1.2.3 Maximum Speeds and Payload of the Double Slider Specification (Option)]

[When high-output setting for motor straight type is effective]

Speed limits [Unit: mm/s]

Type	Motor Type	Lead [mm]	Horizontal/Vertical	Stroke [mm]															
				50	100	150	200	250	300	350	400	450	500	550	600	650	700	750	800
SA4C	35P	2.5	Horizontal	195							165	135	-	-	-	-	-	-	
			Vertical	195							165	135	-	-	-	-	-	-	
		5	Horizontal	390							330	275	-	-	-	-	-	-	
			Vertical	390							330	275	-	-	-	-	-	-	
		10	Horizontal	785							675	555	-	-	-	-	-	-	
			Vertical	785							675	555	-	-	-	-	-	-	
16	Horizontal	1260							1060	875	-	-	-	-	-	-			
	Vertical	1260							1060	875	-	-	-	-	-	-			
SA6C	42P	3	Horizontal	225							215	180	150	130	115	100	85	75	
			Vertical	225							215	180	150	130	115	100	85	75	
		6	Horizontal	450							435	365	305	265	230	200	175	155	
			Vertical	450							435	365	305	265	230	200	175	155	
		12	Horizontal	900							885	735	620	535	460	405	355	315	
			Vertical	900							885	735	620	535	460	405	355	315	
		20	Horizontal	1440							1335	1130	970	840	735	650	575		
			Vertical	1280							1130	970	840	735	650	575			
SA7C	56P	4	Horizontal	245							235	205	175	155	135	120			
			Vertical	210							205	175	155	135	120				
		8	Horizontal	490							475	410	355	315	275	245			
			Vertical	490							475	410	355	315	275	245			
		16	Horizontal	980							965	830	720	635	560	500			
			Vertical	840							830	720	635	560	500				
		24	Horizontal	1200							1095	965	850	760					
			Vertical	1200							1095	965	850	760					

Type	Motor Type	Lead [mm]	Horizontal/Vertical	Stroke [mm]																
				50	100	150	200	250	300	350	400	450	500	550	600	650	700	750	800	
SA8C	56SP	5	Horizontal	250												240	215	190		
			Vertical	250												240	215	190		
		10	Horizontal	500												480	430	385		
			Vertical	500												480	430	385		
		20	Horizontal	1000												950	860	770		
			Vertical	800												770				
		30	Horizontal	1200												1155				
			Vertical	850																
		5	5	/			Stroke [mm]													
							850	900	950	1000	1050	1100								
				Horizontal	175	155	140	130	120	110										
					Vertical	175	155	140	130	120	110									
				10	Horizontal	345	310	285	260	235	220									
					Vertical	345	310	285	260	235	220									
				20	Horizontal	695	630	570	520	480	440									
					Vertical	695	630	570	520	480	440									
				30	Horizontal	1040	940	855	780	715	660									
					Vertical	850	780	715	660											

[When high-output setting for side-mounted motor type is effective]

Speed limits [Unit: mm/s]

Type	Motor Type	Lead [mm]	Horizontal/Vertical	Stroke [mm]																	
				50	100	150	200	250	300	350	400	450	500	550	600	650	700	750	800		
SA4R	35P	2.5	Horizontal					195				165	135	-	-	-	-	-	-		
			Vertical					195				165	135	-	-	-	-	-	-		
		5	Horizontal					390				330	275	-	-	-	-	-	-		
			Vertical					390				330	275	-	-	-	-	-	-		
		10	Horizontal					785				675	555	-	-	-	-	-	-		
			Vertical					785				675	555	-	-	-	-	-	-		
		16	Horizontal					1260				1060	875	-	-	-	-	-	-		
			Vertical					1260				1060	875	-	-	-	-	-	-		
SA6R	42P	3	Horizontal					225				215	180	150	130	115	100	85	75		
			Vertical					225				215	180	150	130	115	100	85	75		
		6	Horizontal					450				435	365	305	265	230	200	175	155		
			Vertical					450				435	365	305	265	230	200	175	155		
		12	Horizontal					900				885	735	620	535	460	405	355	315		
			Vertical					800				735	620	535	460	405	355	315			
		20	Horizontal					1280								1130	970	840	735	650	575
			Vertical					1280								1130	970	840	735	650	575
SA7R	56P	4	Horizontal					210								205	175	155	135	120	
			Vertical					210								205	175	155	135	120	
		8	Horizontal					420								410	355	315	275	245	
			Vertical					420								410	355	315	275	245	
		16	Horizontal					840								830	720	635	560	500	
			Vertical					700								635 560 500					
		24	Horizontal					1080								965 850 760					
			Vertical					1080								965 850 760					

Type	Motor Type	Lead [mm]	Horizontal/Vertical	Stroke [mm]															
				50	100	150	200	250	300	350	400	450	500	550	600	650	700	750	800
SA8R	56SP	5	Horizontal	250												240	215	190	
			Vertical	225												215	190		
		10	Horizontal	500												480	430	385	
			Vertical	450												430	385		
		20	Horizontal	1000												950	860	770	
			Vertical	800												770			
		30	Horizontal	1200												1155			
			Vertical	850															
						Stroke [mm]													
						850	900	950	1000	1050	1100								
		5	Horizontal	175	155	140	130	120	110										
			Vertical	175	155	140	130	120	110										
		10	Horizontal	345	310	285	260	235	220										
			Vertical	345	310	285	260	235	220										
20	Horizontal	695	630	570	520	480	440												
	Vertical	695	630	570	520	480	440												
30	Horizontal	1040	940	855	780	715	660												
	Vertical	850			780	715	660												

 **Caution:** When a speed less than the minimum speed, operation will not made in the set speed.
 Do not attempt to set a speed less than the minimum speed.
 Figure out the minimum speed using the following formula.
 Min. Speed [mm/s] = Lead Length [mm] / 800 / 0.001 [sec]

[When high-output setting for motor straight type is ineffective]

(Note) High-output settings are not available in SA8C or SA8R that operate with the PCON-CFB controller.

Speed limits [Unit: mm/s]

Type	Motor Type	Lead [mm]	Horizontal/ Vertical	Stroke [mm]															
				50	100	150	200	250	300	350	400	450	500	550	600	650	700	750	800
SA4C	35P	2.5	Horizontal	130										-	-	-	-	-	-
			Vertical	130										-	-	-	-	-	-
		5	Horizontal	260										-	-	-	-	-	-
			Vertical	260										-	-	-	-	-	-
		10	Horizontal	525										-	-	-	-	-	-
			Vertical	525										-	-	-	-	-	-
		16	Horizontal	840										-	-	-	-	-	-
			Vertical	840										-	-	-	-	-	-
SA6C	42P	3	Horizontal	170										150	130	115	100	85	75
			Vertical	170										150	130	115	100	85	75
		6	Horizontal	340										305	265	230	200	175	155
			Vertical	340										305	265	230	200	175	155
		12	Horizontal	680										620	535	460	405	355	315
			Vertical	680										620	535	460	405	355	315
		20	Horizontal	960										840			735	650	575
			Vertical	960										840			735	650	575
SA7C	56P	4	Horizontal	140														135	120
			Vertical	140														135	120
		8	Horizontal	280														275	245
			Vertical	280														275	245
		16	Horizontal	560														500	
			Vertical	560														500	
		24	Horizontal	800														760	
			Vertical	800														760	

[When high-output setting for side-mounted motor type is ineffective]

(Note) High-output settings are not available in SA8C or SA8R that operate with the PCON-CFB controller.

Speed limits [Unit: mm/s]

Type	Motor Type	Lead [mm]	Horizontal/ Vertical	Stroke [mm]															
				50	100	150	200	250	300	350	400	450	500	550	600	650	700	750	800
SA4R	35P	2.5	Horizontal	130										-	-	-	-	-	-
			Vertical	130										-	-	-	-	-	-
		5	Horizontal	260										-	-	-	-	-	-
			Vertical	260										-	-	-	-	-	-
		10	Horizontal	525										-	-	-	-	-	-
			Vertical	525										-	-	-	-	-	-
16	Horizontal	840										-	-	-	-	-	-		
	Vertical	840										-	-	-	-	-	-		
SA6R	42P	3	Horizontal	170										150	130	115	100	85	75
			Vertical	170										150	130	115	100	85	75
		6	Horizontal	340										305	265	230	200	175	155
			Vertical	340										305	265	230	200	175	155
		12	Horizontal	680										620	535	460	405	355	315
			Vertical	680										620	535	460	405	355	315
		20	Horizontal	960										840	735	650	575		
			Vertical	960										840	735	650	575		
SA7R	56P	4	Horizontal	140														135	120
			Vertical	140														135	120
		8	Horizontal	280														275	245
			Vertical	280														275	245
		16	Horizontal	560														500	
			Vertical	560														500	
		24	Horizontal	800														760	
			Vertical	800														760	

 **Caution:** When a speed less than the minimum speed, operation will not be made in the set speed.
 Do not attempt to set a speed less than the minimum speed.
 Figure out the minimum speed using the following formula.
 Min. Speed [mm/s] = Lead Length [mm] / 800 / 0.001 [sec]

1.2.2 Maximum Speed and Payload of the Single Slider

If the payload is smaller than as specified, the acceleration/deceleration can be raised beyond the applicable level.

(Note) The table shown below is for the single slider. In the case of the double slider specification (option), the payload decreases more than the single slider (shown in the table below).
 [Refer to 1.2.3 Maximum Speed and Payload of the Double Slider Specification (Option)]

[When high-output setting for motor straight type is effective]

Type	Motor Type	Lead [mm]	Horizontal/ Vertical	Payload by Acceleration/Deceleration [kg]					
				Velocity [mm/s]	0.1G	0.3G	0.5G	0.7G	1.0G
SA4C	35P	2.5	Horizontal	0	18	18	18	18	18
				20	18	18	18	18	18
				40	18	18	18	18	18
				65	18	18	18	18	18
				85	18	18	18	18	18
				105	18	18	18	18	18
				130	18	18	18	18	18
				150	18	18	18	18	18
				175	18	18	18	18	18
			195	18	18	18	18	18	
			Vertical	0	12	12	12	-	-
				20	12	12	12	-	-
				40	12	12	12	-	-
				65	12	12	12	-	-
				85	12	12	12	-	-
				105	12	12	12	-	-
				130	11	11	11	-	-
				150	10	10	10	-	-
		175		9	9	9	-	-	
		195	8	8	8	-	-		
		5	Horizontal	0	14	14	14	14	14
				40	14	14	14	14	14
				85	14	14	14	14	14
				130	14	14	14	14	14
				175	14	14	14	14	14
				215	14	14	14	14	14
				260	14	14	14	14	13
				305	14	14	14	14	12
				350	14	12	12	12	10
			390	14	10	10	10	10	
			Vertical	0	5.5	5.5	5.5	-	-
				40	5.5	5.5	5.5	-	-
				85	5.5	5.5	5.5	-	-
				130	5.5	5.5	5.5	-	-
				175	5.5	5.5	5.5	-	-
				215	5.5	5.5	5.5	-	-
260	5.5			5.5	5.5	-	-		
305	5			5	5	-	-		
350	4.5	4.5		4.5	-	-			
390	4	4	3.5	-	-				

[When high-output setting for motor straight type is effective]

Type	Motor Type	Lead [mm]	Horizontal/ Vertical	Payload by Acceleration/Deceleration [kg]					
				Velocity [mm/s]	0.1G	0.3G	0.5G	0.7G	1.0G
SA4C	35P	10	Horizontal	0	12	12	12	10	9
				85	12	12	12	10	9
				175	12	12	12	10	9
				260	12	12	12	10	9
				350	12	12	12	10	9
				435	12	12	12	10	8
				525	12	12	10	8	7
				610	12	10	8	6	5
			700	-	8	6	4	3	
			785	-	7	4	3	3	
			0	3	3	3	-	-	
			85	3	3	3	-	-	
			175	3	3	3	-	-	
			260	3	3	3	-	-	
		350	3	3	3	-	-		
		435	2.5	2.5	2.5	-	-		
		525	2.25	2.25	2.25	-	-		
		610	2.25	2.25	2.25	-	-		
		700	-	2	1.75	-	-		
		785	-	1.5	1.25	-	-		
		0	7	7	5	5	4.5		
		140	7	7	5	5	4.5		
		280	7	7	5	5	4.5		
		420	7	7	5	5	4.5		
		560	7	7	5	5	4.5		
		700	6	6	5	4.5	4		
		840	-	6	4	4	3.5		
		980	-	4	4	3	2.5		
1120	-	-	2.5	2	1.5				
1260	-	-	2	1.5	1				
0	1.5	1.5	1.5	-	-				
140	1.5	1.5	1.5	-	-				
280	1.5	1.5	1.5	-	-				
420	1.5	1.5	1.5	-	-				
560	1.5	1.5	1.5	-	-				
700	1.5	1.5	1.5	-	-				
840	-	1	1	-	-				
980	-	1	1	-	-				
1120	-	1	0.75	-	-				
1260	-	-	0.5	-	-				

[When high-output setting for motor straight type is effective]

Type	Motor Type	Lead [mm]	Horizontal/ Vertical	Payload by Acceleration/Deceleration [kg]					
				Velocity [mm/s]	0.1G	0.3G	0.5G	0.7G	1.0G
SA6C	42P	3	Horizontal	0	40	40	35	35	35
				20	40	40	35	35	35
				50	40	40	35	35	35
				80	40	40	35	35	30
				110	40	40	35	35	30
				140	40	40	35	35	28
				170	40	40	32	32	24
			200	40	35	28	25	20	
			225	40	28	20	18	14	
			Vertical	0	16	16	16	-	-
				20	16	16	16	-	-
				50	16	16	16	-	-
				80	16	16	16	-	-
				110	16	16	16	-	-
		140		16	15	15	-	-	
		170		14	13	12	-	-	
		200	11	10	9	-	-		
		225	9	8	-	-	-		
		6	Horizontal	0	32	32	26	24	20
				40	32	32	26	24	20
				100	32	32	26	24	20
				160	32	32	26	24	20
				220	32	32	26	24	20
				280	32	32	26	24	15
				340	32	32	20	18	12
			400	32	22	12	11	8	
			450	26	15	8	6	4	
			Vertical	0	6	6	6	-	-
40	6			6	6	-	-		
100	6			6	6	-	-		
160	6			6	6	-	-		
220	6			6	6	-	-		
280	6	6		5.5	-	-			
340	6	5		4.5	-	-			
400	4.5	3.5	3.5	-	-				
450	3.5	2	2	-	-				

[When high-output setting for motor straight type is effective]

Type	Motor Type	Lead [mm]	Horizontal/ Vertical	Payload by Acceleration/Deceleration [kg]					
				Velocity [mm/s]	0.1G	0.3G	0.5G	0.7G	1.0G
SA6C	42P	12	Horizontal	0	28	26	18	16	14
				80	28	26	18	16	14
				200	28	26	18	16	14
				320	28	26	18	14	12
				440	28	26	18	12	10
				560	28	20	12	8	7
				680	20	15	9	5	4
			800	15	9	5	2	1	
			900	-	5	3	1	1	
			Vertical	0	2.5	2.5	2.5	-	-
				80	2.5	2.5	2.5	-	-
				200	2.5	2.5	2.5	-	-
				320	2.5	2.5	2.5	-	-
				440	2.5	2.5	2.5	-	-
		560		2.5	2.5	2.5	-	-	
		680		2.5	2.5	2.5	-	-	
		800	2	2	1	-	-		
		900	-	0.5	0.5	-	-		
		20	Horizontal	0	15	15	10	8	7
				160	15	15	10	8	7
				320	15	12	10	8	6
				480	12	12	9	8	6
				640	12	12	8	6	5
				800	10	10	6.5	4.5	3
				960	-	8	5	3.5	2
			1120	-	6.5	3	2	1.5	
			1280	-	-	1	1	1	
			1440	-	-	1	0.5	-	
Vertical	0		1	1	1	-	-		
	160		1	1	1	-	-		
	320		1	1	1	-	-		
	480		1	1	1	-	-		
	640	1	1	1	-	-			
	800	1	1	1	-	-			
	960	-	1	1	-	-			
1120	-	0.5	0.5	-	-				
1280	-	-	0.5	-	-				
1440	-	-	-	-	-				

[When high-output setting for motor straight type is effective]

Type	Motor Type	Lead [mm]	Horizontal/ Vertical	Payload by Acceleration/Deceleration [kg]					
				Velocity [mm/s]	0.1G	0.3G	0.5G	0.7G	1.0G
SA7C	56P	4	Horizontal	0	55	51	45	40	40
				35	55	51	45	40	40
				70	55	51	45	40	40
				105	55	51	45	40	35
				140	55	45	35	30	25
				175	55	30	18	-	-
				210	45	8	-	-	-
			245	35	-	-	-	-	
			Vertical	0	25	25	25	-	-
				35	25	25	25	-	-
				70	25	25	25	-	-
				105	22	20	19	-	-
				140	16	14	12	-	-
				175	11	9	7.5	-	-
		210		8	-	-	-	-	
		245	-	-	-	-	-		
		8	Horizontal	0	51	51	45	40	40
				70	51	51	45	40	40
				140	51	51	40	38	35
				210	51	51	35	30	24
				280	51	40	28	20	15
				350	51	30	9	4	-
				420	40	7	-	-	-
			490	20	-	-	-	-	
			Vertical	0	16	16	16	-	-
				70	16	16	16	-	-
				140	16	16	16	-	-
				210	11	10	9.5	-	-
280	9			8	7	-	-		
350	7			5	4	-	-		
420	5	2		-	-	-			
490	2	-	-	-	-				

[When high-output setting for motor straight type is effective]

Type	Motor Type	Lead [mm]	Horizontal/ Vertical	Payload by Acceleration/Deceleration [kg]					
				Velocity [mm/s]	0.1G	0.3G	0.5G	0.7G	1.0G
SA7C	56P	16	Horizontal	0	46	46	35	28	27
				140	46	46	35	28	27
				280	46	46	35	25	24
				420	46	34	25	15	10
				560	35	20	15	10	6
				700	20	15	10	5	3
				840	-	9	4	2	-
			980	-	4	-	-	-	
			Vertical	0	8	8	8	-	-
				140	8	8	8	-	-
				280	8	8	8	-	-
				420	6	5	4.5	-	-
				560	5	4	3	-	-
				700	4	3	2	-	-
		840		-	1	-	-	-	
		980	-	-	-	-	-		
		24	Horizontal	0	37	37	22	16	14
				200	37	37	22	16	14
				420	37	34	20	16	14
				640	37	20	15	10	9
				860	-	12	10	7	4
				1080	-	8	4.5	4	2
				1200	-	5.5	2	2	1
			Vertical	0	3	3	3	-	-
200	3			3	3	-	-		
420	3			3	3	-	-		
640	3			3	3	-	-		
860	-			3	2.5	-	-		
1080	-			2	1	-	-		
1200	-			1	-	-	-		

[When high-output setting for motor straight type is effective]

Type	Motor Type	Lead [mm]	Horizontal/ Vertical	Payload by Acceleration/Deceleration [kg]					
				Velocity [mm/s]	0.1G	0.3G	0.5G	0.7G	1.0G
SA8C	56SP	5	Horizontal	0	80	80	80	80	80
				50	80	80	80	80	80
				75	80	80	80	80	80
				100	80	80	80	80	80
				125	80	80	80	70	70
				175	80	70	40	30	25
				200	80	50	20	10	5
				225	80	20	5	-	-
			250	80	-	-	-	-	
			Vertical	0	55	55	55	-	-
				50	55	55	55	-	-
				75	30	30	30	-	-
				100	18	18	18	-	-
				125	18	18	18	-	-
		175		14	12	10	-	-	
		10	Horizontal	200	10	6	5	-	-
				225	7	1	-	-	-
				250	5	-	-	-	-
				0	70	70	70	70	65
				50	70	70	70	70	65
				100	70	70	70	70	65
				200	70	65	50	40	35
				250	70	62	40	31	26
			Vertical	300	70	60	30	25	20
				400	70	25	15	8	5
				500	55	10	2	-	-
				0	25	25	25	-	-
				50	25	25	25	-	-
100	25			25	25	-	-		
200	200	20	20	20	-	-			
	250	13	12	12	-	-			
	300	10	9	9	-	-			
	400	5	3	2	-	-			
	500	3	1	-	-	-			

[When high-output setting for motor straight type is effective]

Type	Motor Type	Lead [mm]	Horizontal/ Vertical	Payload by Acceleration/Deceleration [kg]					
				Velocity [mm/s]	0.1G	0.3G	0.5G	0.7G	1.0G
SA8C	56SP	20	Horizontal	0	60	51	45	40	35
				50	60	51	45	40	32
				100	60	51	45	33	30
				200	60	51	45	33	25
				300	60	51	40	30	23
				400	50	35	30	23	20
				650	50	20	15	8	6
				800	-	10	6	2	1
			900	-	7	3	0.5	-	
			1000	-	4	1	-	-	
			Vertical	0	4	4	4	-	-
				50	4	4	4	-	-
				100	4	4	4	-	-
				200	4	4	4	-	-
		300		4	4	4	-	-	
		400		2	2	2	-	-	
		650		2	2	2	-	-	
		800		1	0.5	-	-	-	
		900	-	-	-	-	-		
		1000	-	-	-	-	-		
		30	Horizontal	0	28	26	20	16	13
				100	28	26	20	16	13
				200	28	26	20	16	13
				400	28	24	18	15	11
				650	21	18	15	12	8
				850	-	14	10	7	5
				1000	-	8	6	3	2
			1200	-	4	2	1	0.5	
Vertical	0		3	3	3	-	-		
	100		3	3	3	-	-		
	200		2	2	2	-	-		
	400		1.5	1.5	1	-	-		
	650		1	1	1	-	-		
	850		-	1	1	-	-		
	1000	-	-	-	-	-			
1200	-	-	-	-	-				

[When high-output setting for side-mounted motor type is effective]

Type	Motor Type	Lead [mm]	Horizontal/ Vertical	Payload by Acceleration/Deceleration [kg]					
				Velocity [mm/s]	0.1G	0.3G	0.5G	0.7G	1.0G
SA4R	35P	2.5	Horizontal	0	18	18	18	18	18
				20	18	18	18	18	18
				40	18	18	18	18	18
				65	18	18	16	16	16
				85	18	18	16	16	16
				105	18	18	16	15	15
				130	18	18	16	15	14
				150	18	18	16	15	14
				175	18	18	16	15	14
			195	18	18	16	14	10	
			Vertical	0	12	12	12	-	-
				20	12	12	12	-	-
				40	12	12	12	-	-
				65	12	12	12	-	-
				85	12	12	12	-	-
				105	12	12	12	-	-
				130	11	11	11	-	-
				150	10	10	10	-	-
		175		8	7	7	-	-	
		195	7	5	5	-	-		
		5	Horizontal	0	14	14	14	12	12
				40	14	14	14	12	12
				85	14	14	14	12	12
				130	14	14	12	12	11
				175	14	14	12	12	11
				215	14	14	12	12	11
				260	14	14	12	12	11
			Vertical	305	14	14	12	12	11
				350	14	12	12	10	10
				390	14	10	7	6	4
				0	5.5	5.5	5.5	-	-
				40	5.5	5.5	5.5	-	-
85	5.5			5.5	5.5	-	-		
130	5.5			5.5	5.5	-	-		
175	5.5	5.5	5.5	-	-				
215	5.5	5.5	5.5	-	-				
260	5.5	5.5	5	-	-				
305	5	5	4.5	-	-				
350	4	4	4	-	-				
390	3.5	3.5	2.5	-	-				

[When high-output setting for side-mounted motor type is effective]

Type	Motor Type	Lead [mm]	Horizontal/ Vertical	Payload by Acceleration/Deceleration [kg]					
				Velocity [mm/s]	0.1G	0.3G	0.5G	0.7G	1.0G
SA4R	35P	10	Horizontal	0	12	12	12	10	9
				85	12	12	12	10	9
				175	12	12	12	10	9
				260	12	12	10	9	9
				350	12	12	10	9	8
				435	12	12	10	9	8
				525	12	12	9	7	7
				610	-	10	7	5	4
			700	-	7	4	3	2	
			785	-	4	3	2	1.5	
			0	3	3	3	-	-	
			85	3	3	3	-	-	
			175	3	3	3	-	-	
			260	3	3	3	-	-	
		350	3	3	3	-	-		
		435	2.5	2.5	2.5	-	-		
		525	2.25	2.25	2.25	-	-		
		610	2.25	2	2	-	-		
		700	-	1.5	1	-	-		
		785	-	1	1	-	-		
		0	7	7	5	4.5	4.5		
		140	7	7	5	4.5	4.5		
		280	7	7	5	4.5	4.5		
		420	7	7	5	4.5	4.5		
		560	7	7	5	4.5	4		
		700	-	6	5	4	4		
		840	-	6	4	3	3		
		980	-	4	4	2.5	2		
1120	-	-	2.5	1	1				
1260	-	-	1	0.5	0.5				
0	1.5	1.5	1.5	-	-				
140	1.5	1.5	1.5	-	-				
280	1.5	1.5	1.5	-	-				
420	1.5	1.5	1.5	-	-				
560	1.5	1.5	1.5	-	-				
700	-	1	1	-	-				
840	-	1	1	-	-				
980	-	1	1	-	-				
1120	-	-	0.5	-	-				
1260	-	-	-	-	-				

[When high-output setting for side-mounted motor type is effective]

Type	Motor Type	Lead [mm]	Horizontal/ Vertical	Payload by Acceleration/Deceleration [kg]					
				Velocity [mm/s]	0.1G	0.3G	0.5G	0.7G	1.0G
SA6R	42P	3	Horizontal	0	40	40	35	35	35
				20	40	40	35	35	35
				50	40	40	35	35	35
				80	40	40	35	35	30
				110	40	40	35	35	30
				140	40	40	35	35	28
				170	40	40	32	32	24
			200	40	35	28	25	18	
			225	40	25	16	12	10	
			Vertical	0	14	14	14	-	-
				20	14	14	14	-	-
				50	14	14	14	-	-
				80	14	14	14	-	-
				110	14	14	14	-	-
		140		14	14	12	-	-	
		170		12	12	10	-	-	
		200	10	8	7	-	-		
		225	6	4	-	-	-		
		6	Horizontal	0	32	32	26	24	20
				40	32	32	26	24	20
				100	32	32	26	24	20
				160	32	32	26	24	20
				220	32	32	26	24	20
				280	32	32	26	24	15
				340	32	32	20	18	12
			400	32	20	12	11	8	
			450	26	12	6	5	3	
			Vertical	0	6	6	6	-	-
40	6			6	6	-	-		
100	6			6	6	-	-		
160	6			6	6	-	-		
220	6			6	6	-	-		
280	6	6		5.5	-	-			
340	6	5		4.5	-	-			
400	4.5	3.5	3.5	-	-				
450	3	2	2	-	-				

[When high-output setting for side-mounted motor type is effective]

Type	Motor Type	Lead [mm]	Horizontal/ Vertical	Payload by Acceleration/Deceleration [kg]					
				Velocity [mm/s]	0.1G	0.3G	0.5G	0.7G	1.0G
SA6R	42P	12	Horizontal	0	28	26	18	16	14
				80	28	26	18	16	14
				200	28	26	18	16	14
				320	28	26	18	14	12
				440	28	26	18	12	10
				560	28	20	12	8	4
				680	20	15	9	5	1
			800	15	9	5	2	1	
			900	-	5	3	1	-	
			Vertical	0	2.5	2.5	2.5	-	-
				80	2.5	2.5	2.5	-	-
				200	2.5	2.5	2.5	-	-
				320	2.5	2.5	2.5	-	-
				440	2.5	2.5	2.5	-	-
		560		2.5	2.5	2.5	-	-	
		680		2.5	2.5	2.5	-	-	
		800	2	1.5	1	-	-		
		900	-	-	-	-	-		
		20	Horizontal	0	15	15	10	8	7
				160	15	15	10	8	7
				320	15	12	10	8	6
				480	12	12	9	8	6
				640	12	12	8	6	5
				800	10	10	6.5	4.5	3
				960	-	8	5	3.5	2
			1120	-	6	3	2	1.5	
			1280	-	-	1	0.5	0.5	
			1440	-	-	-	-	-	
Vertical	0		1	1	1	-	-		
	160		1	1	1	-	-		
	320		1	1	1	-	-		
	480		1	1	1	-	-		
	640	1	1	1	-	-			
	800	1	1	1	-	-			
	960	-	1	1	-	-			
1120	-	0.5	0.5	-	-				
1280	-	-	-	-	-				
1440	-	-	-	-	-				

[When high-output setting for side-mounted motor type is effective]

Type	Motor Type	Lead [mm]	Horizontal/ Vertical	Payload by Acceleration/Deceleration [kg]					
				Velocity [mm/s]	0.1G	0.3G	0.5G	0.7G	1.0G
SA7R	56P	4	Horizontal	0	55	51	45	40	40
				35	55	51	45	40	40
				70	55	51	45	40	40
				105	55	51	45	40	35
				140	55	45	35	30	25
				175	55	30	16	-	-
			210	40	-	-	-	-	
			Vertical	0	25	25	25	-	-
				35	25	25	25	-	-
				70	25	25	25	-	-
				105	22	20	19	-	-
				140	16	14	12	-	-
		175		11	7	5	-	-	
		210	4	-	-	-	-		
		8	Horizontal	0	51	51	45	40	40
				70	51	51	45	40	40
				140	51	51	40	38	35
				210	51	45	35	30	24
				280	51	35	25	20	15
				350	40	20	3	1	-
			420	30	2	-	-	-	
			Vertical	0	16	16	16	-	-
				70	16	16	16	-	-
				140	16	16	16	-	-
210	11			10	9.5	-	-		
280	9			8	7	-	-		
350	7	4		1	-	-			
420	4	-	-	-	-				

[When high-output setting for side-mounted motor type is effective]

Type	Motor Type	Lead [mm]	Horizontal/ Vertical	Payload by Acceleration/Deceleration [kg]					
				Velocity [mm/s]	0.1G	0.3G	0.5G	0.7G	1.0G
SA7R	56P	16	Horizontal	0	46	46	35	28	27
				140	46	46	35	28	27
				280	46	46	35	25	21
				420	46	30	20	15	10
				560	35	20	13	10	6
				700	20	13	6	3	2
			840	-	4	1	-	-	
			Vertical	0	8	8	8	-	-
				140	8	8	8	-	-
				280	8	8	8	-	-
				420	6	5	4.5	-	-
				560	5	4	3	-	-
		700		3	2	1.5	-	-	
		840	-	-	-	-	-		
		24	Horizontal	0	37	37	22	16	14
				200	37	37	22	16	14
				420	37	30	18	16	14
				640	37	18	15	10	9
				860	-	12	10	3	2
				1080	-	2	-	-	-
			Vertical	0	3	3	3	-	-
				200	3	3	3	-	-
				420	3	3	3	-	-
				640	3	3	3	-	-
860	-			3	2.5	-	-		
1080	-			-	0.5	-	-		

[When high-output setting for side-mounted motor type is effective]

Type	Motor Type	Lead [mm]	Horizontal/ Vertical	Payload by Acceleration/Deceleration [kg]					
				Velocity [mm/s]	0.1G	0.3G	0.5G	0.7G	1.0G
SA8R	56SP	5	Horizontal	0	80	80	80	80	80
				50	80	80	80	80	80
				75	80	80	80	80	80
				100	80	80	80	80	80
				125	80	80	80	70	70
				175	80	70	35	30	25
				200	80	40	14	4	2
			225	80	10	-	-	-	
			250	65	-	-	-	-	
			Vertical	0	55	55	55	-	-
				50	55	55	55	-	-
				75	30	30	30	-	-
				100	18	18	18	-	-
				125	18	18	18	-	-
		175		14	11	10	-	-	
		200		8	3	2	-	-	
		225	5	0.5	-	-	-		
		250	2	-	-	-	-		
		10	Horizontal	0	70	70	70	70	65
				50	70	70	70	70	65
				100	70	70	70	70	65
				200	70	60	50	40	35
				250	70	52	40	30	27
				300	70	45	30	20	20
				400	65	15	9	4	1
			450	45	11	2	-	-	
			500	25	4	-	-	-	
			Vertical	0	25	25	25	-	-
50	25			25	25	-	-		
100	25			25	25	-	-		
200	14			14	14	-	-		
250	9			9	9	-	-		
300	7	7		7	-	-			
400	3	2		1	-	-			
450	1	0.5	-	-	-				
500	-	-	-	-	-				

[When high-output setting for side-mounted motor type is effective]

Type	Motor Type	Lead [mm]	Horizontal/ Vertical	Payload by Acceleration/Deceleration [kg]					
				Velocity [mm/s]	0.1G	0.3G	0.5G	0.7G	1.0G
SA8R	56SP	20	Horizontal	0	55	51	35	33	30
				50	55	51	35	33	30
				100	55	51	35	33	30
				200	55	51	35	33	25
				300	55	51	35	24	16
				400	45	35	22	18	12
				650	40	20	9	4	3
				800	-	10	3	1	0.5
			900	-	7	1	-	-	
			1000	-	4	-	-	-	
			Vertical	0	4	4	4	-	-
				50	4	4	4	-	-
				100	4	4	4	-	-
				200	4	4	4	-	-
		300		4	4	4	-	-	
		400		2	2	2	-	-	
		650	2	2	2	-	-		
		800	1	0.5	-	-	-		
		900	-	-	-	-	-		
		1000	-	-	-	-	-		
		30	Horizontal	0	26	24	18	15	13
				100	26	24	18	15	13
				200	26	24	16	15	13
				400	24	20	13	12	11
				650	21	14	10	9	8
				850	-	9	6	4	2
				1000	-	5	3	2	1
				1200	-	1	-	-	-
Vertical	0		3	3	3	-	-		
	100		3	3	3	-	-		
	200		2	2	2	-	-		
	400		1.5	1.5	1	-	-		
	650		1	1	1	-	-		
	850		-	1	1	-	-		
1000	-	-	-	-	-				
1200	-	-	-	-	-				

 Caution: Do not attempt to establish the settings for the acceleration/deceleration above the allowable range. It may cause a vibration, malfunction or shorten the product life. If any acceleration/deceleration equal to or greater than the rated acceleration/deceleration is set, a creep phenomenon or slipped coupling may occur.

(Note) High-output settings are not available in SA8C or SA8R that operate with the PCON-CFB controller.

[When high-output setting for motor straight type is ineffective]

Type	Motor Type	Lead [mm]	Horizontal/ Vertical	Payload by Acceleration/Deceleration [kg]		
				Velocity [mm/s]	0.3G	0.7G
SA4C	35P	2.5	Horizontal	0	12	12
				20	12	12
				40	12	12
				65	12	11
				85	11	10
				105	10	9
			Vertical	130	10	8
				0	9	-
				20	9	-
				40	9	-
				65	8	-
				85	8	-
		5	Horizontal	105	8	-
				130	5	-
				0	12	10
				40	12	10
				85	12	10
				130	10	9
			Vertical	175	10	8
				215	9	7
				260	8	6
				0	4.5	-
				40	4.5	-
				85	4.5	-
Vertical	130	4	-			
	175	4	-			
	215	4	-			
	260	2.5	-			

[When high-output setting for motor straight type is ineffective]

Type	Motor Type	Lead [mm]	Horizontal/ Vertical	Payload by Acceleration/Deceleration [kg]		
				Velocity [mm/s]	0.3G	0.7G
SA4C	35P	10	Horizontal	0	10	8
				85	10	8
				175	10	8
				260	9	6
				350	7	5
				435	6	4
			525	5	3	
			Vertical	0	2.25	-
				85	2.25	-
				175	2.25	-
				260	2	-
				350	2	-
		435		1.5	-	
		16	Horizontal	0	4	3.5
				140	4	3.5
				280	4	3.5
				420	4	3
				560	3.5	2.5
				700	3	2
			840	2.5	1.5	
			Vertical	0	1	-
				140	1	-
				280	1	-
				420	0.75	-
560	0.75			-		
700	0.5	-				
840	0.5	-				

[When high-output setting for motor straight type is ineffective]

Type	Motor Type	Lead [mm]	Horizontal/ Vertical	Payload by Acceleration/Deceleration [kg]		
				Velocity [mm/s]	0.3G	0.7G
SA6C	42P	3	Horizontal	0	25	22
				20	25	22
				50	25	22
				80	25	22
				110	20	14
				140	15	11
				170	11	9
			Vertical	0	10	-
				20	10	-
				50	10	-
				80	10	-
				110	8	-
				140	5	-
				170	2	-
		6	Horizontal	0	20	14
				40	20	14
				100	20	14
				160	20	14
				220	16	14
				280	13	7
				340	10	1
			Vertical	0	5	-
				40	5	-
				100	5	-
160	5			-		
220	4			-		
280	2.5			-		
340	1			-		

[When high-output setting for motor straight type is ineffective]

Type	Motor Type	Lead [mm]	Horizontal/ Vertical	Payload by Acceleration/Deceleration [kg]		
				Velocity [mm/s]	0.3G	0.7G
SA6C	42P	12	Horizontal	0	14	10
				80	14	10
				200	14	10
				320	14	10
				440	11	7
				560	7	2.5
			680	4	1	
			Vertical	0	2	-
				80	2	-
				200	2	-
				320	2	-
				440	1.5	-
		560		1	-	
		20	Horizontal	680	0.5	-
				0	8	5
				160	8	5
				320	8	5
				480	8	4
				640	6	3
			Vertical	800	4	1.5
				960	2	0.5
				0	0.75	-
				160	0.75	-
				320	0.75	-
480	0.75			-		
640	0.75	-				
800	0.75	-				
960	0.5	-				

[When high-output setting for motor straight type is ineffective]

Type	Motor Type	Lead [mm]	Horizontal/ Vertical	Payload by Acceleration/Deceleration [kg]		
				Velocity [mm/s]	0.3G	0.7G
SA7C	56P	4	Horizontal	0	40	30
				35	40	30
				70	40	30
				105	40	30
			140	15	6	
			Vertical	0	15	-
				35	15	-
				70	15	-
		105		8	-	
		140	2	-		
		8	Horizontal	0	40	25
				70	40	25
				140	40	25
				210	25	14
			280	10	1	
			Vertical	0	10	-
70	10			-		
140	7			-		
210	4	-				
280	1.5	-				

[When high-output setting for motor straight type is ineffective]

Type	Motor Type	Lead [mm]	Horizontal/ Vertical	Payload by Acceleration/Deceleration [kg]		
				Velocity [mm/s]	0.3G	0.7G
SA7C	56P	16	Horizontal	0	35	20
				140	35	20
				280	25	12
				420	15	6
				560	7	0.5
			Vertical	0	5	-
				140	5	-
				280	3	-
				420	1.5	-
				560	0.5	-
		24	Horizontal	0	18	10
				200	18	10
				420	18	10
				640	10	2
				800	5	0.5
			Vertical	0	2	-
200	2			-		
420	2			-		
640	1			-		
800	0.5			-		

(Note) High-output settings are not available in SA8C or SA8R that operate with the PCON-CFB controller.

[When high-output setting for side-mounted motor type is ineffective]

Type	Motor Type	Lead [mm]	Horizontal/ Vertical	Payload by Acceleration/Deceleration [kg]		
				Velocity [mm/s]	0.3G	0.7G
SA4R	35P	2.5	Horizontal	0	12	12
				20	12	12
				40	12	12
				65	12	11
				85	11	10
				105	10	9
				130	10	8
			Vertical	0	9	-
				20	9	-
				40	9	-
				65	8	-
				85	8	-
				105	8	-
				130	5	-
		5	Horizontal	0	12	10
				40	12	10
				85	12	10
				130	10	9
				175	10	8
				215	9	7
				260	8	6
			Vertical	0	4.5	-
				40	4.5	-
				85	4.5	-
				130	4	-
				175	4	-
				215	4	-
				260	2.5	-

[When high-output setting for side-mounted motor type is ineffective]

Type	Motor Type	Lead [mm]	Horizontal/ Vertical	Payload by Acceleration/Deceleration [kg]		
				Velocity [mm/s]	0.3G	0.7G
SA4R	35P	10	Horizontal	0	10	8
				85	10	8
				175	10	8
				260	9	6
				350	7	5
				435	6	4
			525	5	3	
			Vertical	0	2.25	-
				85	2.25	-
				175	2.25	-
				260	2	-
				350	2	-
		435		1.5	-	
		16	Horizontal	0	4	3.5
				140	4	3.5
				280	4	3.5
				420	4	3
				560	3.5	2.5
				700	3	2
			Vertical	840	2.5	1.5
				0	1	-
				140	1	-
				280	1	-
				420	0.75	-
560	0.75			-		
700	0.5	-				
840	0.5	-				

[When high-output setting for side-mounted motor type is ineffective]

Type	Motor Type	Lead [mm]	Horizontal/ Vertical	Payload by Acceleration/Deceleration [kg]		
				Velocity [mm/s]	0.3G	0.7G
SA6R	42P	3	Horizontal	0	25	22
				20	25	22
				50	25	22
				80	25	22
				110	20	14
				140	15	11
				170	11	9
			Vertical	0	10	-
				20	10	-
				50	10	-
				80	10	-
				110	8	-
				140	5	-
				170	2	-
		6	Horizontal	0	20	14
				40	20	14
				100	20	14
				160	20	14
				220	16	14
				280	13	7
				340	10	1
			Vertical	0	5	-
				40	5	-
				100	5	-
				160	5	-
				220	4	-
				280	2.5	-
				340	1	-

[When high-output setting for side-mounted motor type is ineffective]

Type	Motor Type	Lead [mm]	Horizontal/ Vertical	Payload by Acceleration/Deceleration [kg]		
				Velocity [mm/s]	0.3G	0.7G
SA6R	42P	12	Horizontal	0	14	10
				80	14	10
				200	14	10
				320	14	10
				440	11	7
				560	7	2.5
				680	4	1
			Vertical	0	2	-
				80	2	-
				200	2	-
				320	2	-
				440	1.5	-
				560	1	-
				680	0.5	-
		20	Horizontal	0	8	5
				160	8	5
				320	8	5
				480	8	4
				640	6	3
				800	4	1.5
				960	2	0.5
			Vertical	0	0.75	-
				160	0.75	-
				320	0.75	-
				480	0.75	-
				640	0.75	-
				800	0.75	-
				960	0.5	-

[When high-output setting for side-mounted motor type is ineffective]

Type	Motor Type	Lead [mm]	Horizontal/ Vertical	Payload by Acceleration/Deceleration [kg]		
				Velocity [mm/s]	0.3G	0.7G
SA7R	56P	4	Horizontal	0	40	30
				35	40	30
				70	40	30
				105	40	30
			140	15	6	
			Vertical	0	15	-
				35	15	-
				70	15	-
		105		8	-	
		8	Horizontal	140	2	-
				0	40	25
				70	40	25
				140	40	25
			210	25	14	
			280	10	1	
			Vertical	0	10	-
70	10			-		
140	7	-				
210	4	-				
280	1.5	-				

[When high-output setting for side-mounted motor type is ineffective]

Type	Motor Type	Lead [mm]	Horizontal/ Vertical	Payload by Acceleration/Deceleration [kg]		
				Velocity [mm/s]	0.3G	0.7G
SA7R	56P	16	Horizontal	0	35	20
				140	35	20
				280	25	12
				420	15	6
			560	7	0.5	
			Vertical	0	5	-
				140	5	-
				280	3	-
		420		1.5	-	
		560	0.5	-		
		24	Horizontal	0	18	10
				200	18	10
				420	18	10
				640	10	2
			800	5	0.5	
			Vertical	0	2	-
200	2			-		
420	2			-		
640	1	-				
800	0.5	-				

 **Caution:** Do not attempt to establish the settings for the acceleration/deceleration above the allowable range. It may cause a vibration, malfunction or shorten the product life. If any acceleration/deceleration equal to or greater than the rated acceleration/deceleration is set, a creep phenomenon or slipped coupling may occur.

1.2.3 Maximum Speed and Payload of the Double Slider Specification (Option)

In the case of the double slider specification (option), the payload will be lower than what is described in the table of 1.2.2. Maximum Speed and Payload of the Single Slider

These are calculated with the following formulas. The results of the calculations are shown over the next few pages.

[1] Other than SA8C and SA8R

[When the speed of compensation is equal to or less than the compensation speed of the transported mass (mm/s) described in the following table]

Payload [kg] = single slider payload [kg] - compensation value A of the transported mass [kg]

[When the speed of compensation is more than the compensation speed of the transported mass (mm/s) described in the following table]

Payload [kg] = single slider payload [kg] - compensation value B of the transported mass [kg]

[2] SA8C and SA8R

Payload [kg] = single slider payload [kg] - compensation value A of the transported mass [kg]

(Note) Leads not described in the following table cannot be selected with the double slider specification (option). Also, the vertical settings of leads displayed in the table cannot be used by the double slider.

Series	Type	Lead [mm]	Transported Mass Compensation Speed [mm/s]	Transported Mass Compensation Value A [kg]	Transported Mass Compensation Value B [kg]	The Double Slider Cannot be Used
RCP6(S)	SA4C(R)	2.5	105	0.6	2	Vertical setting of lead 10
		5	215			
		10	350			
	SA6C(R)	3	140	1.2	2	Vertical setting of lead 12
		6	280			
		12	320			
	SA7C(R)	4	70	1.7	5	Vertical setting of lead 16
		8	140			
		16	280			
	SA8C(R)	5	-	7	-	Vertical setting of lead 20
		10	-			
		20	-			
RCP6(S)CR	SA4C	2.5	105	0.6	2	Vertical setting of lead 10
		5	215			
		10	350			
	SA6C	3	140	1.2	2	Vertical setting of lead 12
		6	280			
		12	320			
	SA7C	4	70	1.7	5	Vertical setting of lead 16
		8	140			
		16	280			
	SA8C	5	-	7	-	Vertical setting of lead 20
		10	-			
		20	-			

If the payload is smaller than as specified, the acceleration/deceleration can be raised beyond the applicable level.

[When high-output setting for motor straight type double slider specification is effective]

Type	Motor Type	Lead [mm]	Horizontal/ Vertical	Payload by Acceleration/Deceleration [kg]					
				Velocity [mm/s]	0.1G	0.3G	0.5G	0.7G	1.0G
SA4C	35P	2.5	Horizontal	0	17.4	17.4	17.4	17.4	17.4
				20	17.4	17.4	17.4	17.4	17.4
				40	17.4	17.4	17.4	17.4	17.4
				65	17.4	17.4	17.4	17.4	17.4
				85	17.4	17.4	17.4	17.4	17.4
				105	17.4	17.4	17.4	17.4	17.4
				130	16	16	16	16	16
				150	16	16	16	16	16
				175	16	16	16	16	16
			195	16	16	16	16	16	
			Vertical	0	11.4	11.4	11.4	-	-
				20	11.4	11.4	11.4	-	-
				40	11.4	11.4	11.4	-	-
				65	11.4	11.4	11.4	-	-
				85	11.4	11.4	11.4	-	-
				105	11.4	11.4	11.4	-	-
				130	9	9	9	-	-
				150	8	8	8	-	-
		175		7	7	7	-	-	
		195	6	6	6	-	-		
		5	Horizontal	0	13.4	13.4	13.4	13.4	13.4
				40	13.4	13.4	13.4	13.4	13.4
				85	13.4	13.4	13.4	13.4	13.4
				130	13.4	13.4	13.4	13.4	13.4
				175	13.4	13.4	13.4	13.4	13.4
				215	13.4	13.4	13.4	13.4	13.4
				260	12	12	12	12	11
				305	12	12	12	12	10
				350	12	10	10	10	8
			390	12	8	8	8	8	
			Vertical	0	4.9	4.9	4.9	-	-
				40	4.9	4.9	4.9	-	-
				85	4.9	4.9	4.9	-	-
				130	4.9	4.9	4.9	-	-
				175	4.9	4.9	4.9	-	-
				215	4.9	4.9	4.9	-	-
260	3.5			3.5	3.5	-	-		
305	3			3	3	-	-		
350	2.5	2.5		2.5	-	-			
390	2	2	1.5	-	-				
10	Horizontal	0	11.4	11.4	11.4	9.4	8.4		
		85	11.4	11.4	11.4	9.4	8.4		
		175	11.4	11.4	11.4	9.4	8.4		
		260	11.4	11.4	11.4	9.4	8.4		
		350	11.4	11.4	11.4	9.4	8.4		
		435	10	10	10	8	6		
		525	10	10	8	6	5		
		610	10	8	6	4	3		
		700	-	6	4	2	1		
785	-	5	2	1	1				

[When high-output setting for motor straight type double slider specification is effective]

Type	Motor Type	Lead [mm]	Horizontal/ Vertical	Payload by Acceleration/Deceleration [kg]					
				Velocity [mm/s]	0.1G	0.3G	0.5G	0.7G	1.0G
SA6C	42P	3	Horizontal	0	38.8	38.8	33.8	33.8	33.8
				20	38.8	38.8	33.8	33.8	33.8
				50	38.8	38.8	33.8	33.8	33.8
				80	38.8	38.8	33.8	33.8	28.8
				110	38.8	38.8	33.8	33.8	28.8
				140	38.8	38.8	33.8	33.8	26.8
				170	38	38	30	30	22
				200	38	33	26	23	18
			225	38	26	18	16	12	
			Vertical	0	14.8	14.8	14.8	-	-
				20	14.8	14.8	14.8	-	-
				50	14.8	14.8	14.8	-	-
				80	14.8	14.8	14.8	-	-
				110	14.8	14.8	14.8	-	-
		140		14.8	13.8	13.8	-	-	
		170		12	11	10	-	-	
		200		9	8	7	-	-	
		225	7	6	-	-	-		
		6	Horizontal	0	30.8	30.8	24.8	22.8	18.8
				40	30.8	30.8	24.8	22.8	18.8
				100	30.8	30.8	24.8	22.8	18.8
				160	30.8	30.8	24.8	22.8	18.8
				220	30.8	30.8	24.8	22.8	18.8
				280	30.8	30.8	24.8	22.8	13.8
				340	30	30	18	16	10
				400	30	20	10	9	6
				450	24	13	6	4	2
			Vertical	0	4.8	4.8	4.8	-	-
				40	4.8	4.8	4.8	-	-
				100	4.8	4.8	4.8	-	-
				160	4.8	4.8	4.8	-	-
				220	4.8	4.8	4.8	-	-
				280	4.8	4.8	4.3	-	-
				340	4	3	2.5	-	-
				400	2.5	1.5	1.5	-	-
				450	1.5	-	-	-	-
12	Horizontal	0	26.8	24.8	16.8	14.8	12.8		
		80	26.8	24.8	16.8	14.8	12.8		
		200	26.8	24.8	16.8	14.8	12.8		
		320	26.8	24.8	16.8	12.8	10.8		
		440	26	24	16	10	8		
		560	26	18	10	6	5		
		680	18	13	7	3	2		
		800	13	7	3	-	-		
900	-	3	1	-	-				

[When high-output setting for motor straight type double slider specification is effective]

Type	Motor Type	Lead [mm]	Horizontal/ Vertical	Payload by Acceleration/Deceleration [kg]					
				Velocity [mm/s]	0.1G	0.3G	0.5G	0.7G	1.0G
SA7C	56P	4	Horizontal	0	53.3	49.3	43.3	38.3	38.3
				35	53.3	49.3	43.3	38.3	38.3
				70	53.3	49.3	43.3	38.3	38.3
				105	50	46	40	35	30
				140	50	40	30	25	20
				175	50	25	13	-	-
				210	40	3	-	-	-
			245	30	-	-	-	-	
			Vertical	0	23.3	23.3	23.3	-	-
				35	23.3	23.3	23.3	-	-
				70	23.3	23.3	23.3	-	-
				105	17	15	14	-	-
				140	11	9	7	-	-
				175	6	4	2.5	-	-
		210		3	-	-	-	-	
		245	-	-	-	-	-		
		8	Horizontal	0	49.3	49.3	43.3	38.3	38.3
				70	49.3	49.3	43.3	38.3	38.3
				140	49.3	49.3	38.3	36.3	33.3
				210	46	46	30	25	19
				280	46	35	23	15	10
				350	46	25	4	-	-
				420	35	2	-	-	-
				490	15	-	-	-	-
			Vertical	0	14.3	14.3	14.3	-	-
				70	14.3	14.3	14.3	-	-
				140	14.3	14.3	14.3	-	-
				210	6	5	4.5	-	-
				280	4	3	2	-	-
				350	2	-	-	-	-
420	-			-	-	-	-		
490	-			-	-	-	-		
16	Horizontal	0	44.3	44.3	33.3	26.3	25.3		
		140	44.3	44.3	33.3	26.3	25.3		
		280	44.3	44.3	33.3	23.3	22.3		
		420	41	29	20	10	5		
		560	30	15	10	5	1		
		700	15	10	5	-	-		
		840	-	4	-	-	-		
		980	-	-	-	-	-		

[When high-output setting for motor straight type double slider specification is effective]

Type	Motor Type	Lead [mm]	Horizontal/ Vertical	Payload by Acceleration/Deceleration [kg]					
				Velocity [mm/s]	0.1G	0.3G	0.5G	0.7G	1.0G
SA8C	56SP	5	Horizontal	0	73	73	73	73	73
				50	73	73	73	73	73
				75	73	73	73	73	73
				100	73	73	73	73	73
				125	73	73	73	63	63
				175	73	63	33	23	18
				200	73	43	13	3	-
			225	73	13	-	-	-	
			250	73	-	-	-	-	
			Vertical	0	48	48	48	-	-
				50	48	48	48	-	-
				75	23	23	23	-	-
				100	11	11	11	-	-
				125	11	11	11	-	-
		175		7	5	3	-	-	
		200		3	-	-	-	-	
		225	-	-	-	-	-		
		250	-	-	-	-	-		
		10	Horizontal	0	63	63	63	63	58
				50	63	63	63	63	58
				100	63	63	63	63	58
				200	63	58	43	33	28
				250	63	55	33	24	19
				300	63	53	23	18	13
				400	63	18	8	1	-
			500	48	3	-	-	-	
			Vertical	0	18	18	18	-	-
				50	18	18	18	-	-
				100	18	18	18	-	-
				200	13	13	13	-	-
				250	6	5	5	-	-
				300	3	2	2	-	-
		400		-	-	-	-	-	
		500	-	-	-	-	-		
		20	Horizontal	0	53	44	38	33	28
				50	53	44	38	33	25
100	53			44	38	26	23		
200	53			44	38	26	18		
300	53			44	33	23	16		
400	43			28	23	16	13		
650	43			13	8	1	-		
800	-			3	-	-	-		
900	-			-	-	-	-		
1000	-			-	-	-	-		

[When high-output setting for side-mounted type double slider specification is effective]

Type	Motor Type	Lead [mm]	Horizontal/ Vertical	Payload by Acceleration/Deceleration [kg]					
				Velocity [mm/s]	0.1G	0.3G	0.5G	0.7G	1.0G
SA4R	35P	2.5	Horizontal	0	17.4	17.4	17.4	17.4	17.4
				20	17.4	17.4	17.4	17.4	17.4
				40	17.4	17.4	17.4	17.4	17.4
				65	17.4	17.4	15.4	15.4	15.4
				85	17.4	17.4	15.4	15.4	15.4
				105	17.4	17.4	15.4	14.4	14.4
				130	16	16	14	13	12
				150	16	16	14	13	12
				175	16	16	14	13	12
			195	16	16	14	12	8	
			Vertical	0	11.4	11.4	11.4	-	-
				20	11.4	11.4	11.4	-	-
				40	11.4	11.4	11.4	-	-
				65	11.4	11.4	11.4	-	-
				85	11.4	11.4	11.4	-	-
				105	11.4	11.4	11.4	-	-
				130	9	9	9	-	-
				150	8	8	8	-	-
		175		6	5	5	-	-	
		195	5	3	3	-	-		
		5	Horizontal	0	13.4	13.4	13.4	11.4	11.4
				40	13.4	13.4	13.4	11.4	11.4
				85	13.4	13.4	13.4	11.4	11.4
				130	13.4	13.4	11.4	11.4	10.4
				175	13.4	13.4	11.4	11.4	10.4
				215	13.4	13.4	11.4	11.4	10.4
				260	12	12	10	10	9
				305	12	12	10	10	9
				350	12	10	10	8	8
			390	12	8	5	4	2	
			Vertical	0	4.9	4.9	4.9	-	-
				40	4.9	4.9	4.9	-	-
				85	4.9	4.9	4.9	-	-
				130	4.9	4.9	4.9	-	-
				175	4.9	4.9	4.9	-	-
				215	4.9	4.9	4.9	-	-
260	3.5			3.5	3	-	-		
305	3			3	2.5	-	-		
350	2	2		2	-	-			
390	1.5	1.5	0.5	-	-				
10	Horizontal	0	11.4	11.4	11.4	9.4	8.4		
		85	11.4	11.4	11.4	9.4	8.4		
		175	11.4	11.4	11.4	9.4	8.4		
		260	11.4	11.4	9.4	8.4	8.4		
		350	11.4	11.4	9.4	8.4	7.4		
		435	10	10	8	7	6		
		525	10	10	7	5	5		
		610	-	8	5	3	2		
		700	-	5	2	1	-		
785	-	2	1	-	-				

[When high-output setting for side-mounted type double slider specification is effective]

Type	Motor Type	Lead [mm]	Horizontal/ Vertical	Payload by Acceleration/Deceleration [kg]					
				Velocity [mm/s]	0.1G	0.3G	0.5G	0.7G	1.0G
SA6R	42P	3	Horizontal	0	38.8	38.8	33.8	33.8	33.8
				20	38.8	38.8	33.8	33.8	33.8
				50	38.8	38.8	33.8	33.8	33.8
				80	38.8	38.8	33.8	33.8	28.8
				110	38.8	38.8	33.8	33.8	28.8
				140	38.8	38.8	33.8	33.8	26.8
				170	38	38	30	30	22
				200	38	33	26	23	16
			225	38	23	14	10	8	
			Vertical	0	12.8	12.8	12.8	-	-
				20	12.8	12.8	12.8	-	-
				50	12.8	12.8	12.8	-	-
				80	12.8	12.8	12.8	-	-
				110	12.8	12.8	12.8	-	-
		140		12.8	12.8	10.8	-	-	
		170		10	10	8	-	-	
		200		8	6	5	-	-	
		225	4	2	-	-	-		
		6	Horizontal	0	30.8	30.8	24.8	22.8	18.8
				40	30.8	30.8	24.8	22.8	18.8
				100	30.8	30.8	24.8	22.8	18.8
				160	30.8	30.8	24.8	22.8	18.8
				220	30.8	30.8	24.8	22.8	18.8
				280	30.8	30.8	24.8	22.8	13.8
				340	30	30	18	16	10
				400	30	18	10	9	6
				450	24	10	4	3	1
			Vertical	0	4.8	4.8	4.8	-	-
				40	4.8	4.8	4.8	-	-
				100	4.8	4.8	4.8	-	-
				160	4.8	4.8	4.8	-	-
				220	4.8	4.8	4.8	-	-
				280	4.8	4.8	4.3	-	-
				340	4	3	2.5	-	-
				400	2.5	1.5	1.5	-	-
				450	1	-	-	-	-
12	Horizontal	0	26.8	24.8	16.8	14.8	12.8		
		80	26.8	24.8	16.8	14.8	12.8		
		200	26.8	24.8	16.8	14.8	12.8		
		320	26.8	24.8	16.8	12.8	10.8		
		440	26	24	16	10	8		
		560	26	18	10	6	5		
		680	18	13	7	3	1		
		800	13	7	3	-	-		
		900	-	3	1	-	-		

[When high-output setting for side-mounted type double slider specification is effective]

Type	Motor Type	Lead [mm]	Horizontal/ Vertical	Payload by Acceleration/Deceleration [kg]					
				Velocity [mm/s]	0.1G	0.3G	0.5G	0.7G	1.0G
SA7R	56P	4	Horizontal	0	53.3	49.3	43.3	38.3	38.3
				35	53.3	49.3	43.3	38.3	38.3
				70	53.3	49.3	43.3	38.3	38.3
				105	50	46	40	35	30
				140	50	40	30	25	20
				175	50	25	11	-	-
			210	35	-	-	-	-	
			Vertical	0	23.3	23.3	23.3	-	-
				35	23.3	23.3	23.3	-	-
				70	23.3	23.3	23.3	-	-
				105	17	15	14	-	-
				140	11	9	7	-	-
		175		6	2	-	-	-	
		210	-	-	-	-	-		
		8	Horizontal	0	49.3	49.3	43.3	38.3	38.3
				70	49.3	49.3	43.3	38.3	38.3
				140	49.3	49.3	38.3	36.3	33.3
				210	46	40	30	25	19
				280	46	30	20	15	10
				350	35	15	-	-	-
			420	25	-	-	-	-	
			Vertical	0	14.3	14.3	14.3	-	-
				70	14.3	14.3	14.3	-	-
				140	14.3	14.3	14.3	-	-
				210	6	5	4.5	-	-
				280	4	3	2	-	-
		350		2	-	-	-	-	
		420	-	-	-	-	-		
		16	Horizontal	0	44.3	44.3	33.3	26.3	25.3
				140	44.3	44.3	33.3	26.3	25.3
280	44.3			44.3	33.3	23.3	19.3		
420	41			25	15	10	5		
560	30			15	8	5	1		
700	15			8	1	-	-		
840	-			-	-	-	-		

[When high-output setting for side-mounted type double slider specification is effective]

Type	Motor Type	Lead [mm]	Horizontal/ Vertical	Payload by Acceleration/Deceleration [kg]					
				Velocity [mm/s]	0.1G	0.3G	0.5G	0.7G	1.0G
SA8R	56SP	5	Horizontal	0	73	73	73	73	73
				50	73	73	73	73	73
				75	73	73	73	73	73
				100	73	73	73	73	73
				125	73	73	73	63	63
				175	73	63	28	23	18
				200	73	33	7	-	-
				225	73	3	-	-	-
			250	58	-	-	-	-	
			Vertical	0	48	48	48	-	-
				50	48	48	48	-	-
				75	23	23	23	-	-
				100	11	11	11	-	-
				125	11	11	11	-	-
				175	7	4	3	-	-
				200	1	-	-	-	-
		225		-	-	-	-	-	
		250	-	-	-	-	-		
		10	Horizontal	0	63	63	63	63	58
				50	63	63	63	63	58
				100	63	63	63	63	58
				200	63	53	43	33	28
				250	63	38	23	13	13
				400	58	8	2	-	-
				450	38	4	-	-	-
				500	18	-	-	-	-
			Vertical	0	18	18	18	-	-
				50	18	18	18	-	-
				100	18	18	18	-	-
				200	7	7	7	-	-
				250	2	2	2	-	-
				300	-	-	-	-	-
				400	-	-	-	-	-
				450	-	-	-	-	-
		500	-	-	-	-	-		
		20	Horizontal	0	48	44	28	26	23
50	48			44	28	26	23		
100	48			44	28	26	23		
200	48			44	28	26	18		
300	48			44	28	17	9		
400	38			28	15	11	5		
650	33			13	2	-	-		
800	-			3	-	-	-		
900	-			-	-	-	-		
1000	-			-	-	-	-		

 **Caution:** Do not attempt to establish the settings for the acceleration/deceleration above the allowable range. It may cause a vibration, malfunction or shorten the product life. If any acceleration/deceleration equal to or greater than the rated acceleration/deceleration is set, a creep phenomenon or slipped coupling may occur.

(Note) High-output settings are not available in SA8C or SA8R that operate with the PCON-CFB controller.

[When high-output setting for motor straight type double slider specification is ineffective]

Type	Motor Type	Lead [mm]	Horizontal/ Vertical	Payload by Acceleration/Deceleration [kg]		
				Velocity [mm/s]	0.3G	0.7G
SA4C	35P	2.5	Horizontal	0	11.4	11.4
				20	11.4	11.4
				40	11.4	11.4
				65	11.4	10.4
				85	10.4	9.4
				105	9.4	8.4
				130	8	6
			Vertical	0	8.4	-
				20	8.4	-
				40	8.4	-
				65	7.4	-
				85	7.4	-
				105	7.4	-
				130	3	-
		5	Horizontal	0	11.4	9.4
				40	11.4	9.4
				85	11.4	9.4
				130	9.4	8.4
				175	9.4	7.4
				215	8.4	6.4
				260	6	4
			Vertical	0	3.9	-
				40	3.9	-
				85	3.9	-
				130	3.4	-
				175	3.4	-
				215	3.4	-
10	Horizontal	0	9.4	7.4		
		85	9.4	7.4		
		175	9.4	7.4		
		260	8.4	5.4		
		350	6.4	4.4		
		435	4	2		
		525	3	1		

[When high-output setting for motor straight type double slider specification is ineffective]

Type	Motor Type	Lead [mm]	Horizontal/ Vertical	Payload by Acceleration/Deceleration [kg]		
				Velocity [mm/s]	0.3G	0.7G
SA6C	42P	3	Horizontal	0	23.8	20.8
				20	23.8	20.8
				50	23.8	20.8
				80	23.8	20.8
				110	18.8	12.8
				140	13.8	9.8
				170	9	7
			Vertical	0	8.8	-
				20	8.8	-
				50	8.8	-
				80	8.8	-
				110	6.8	-
				140	3.8	-
				170	-	-
		6	Horizontal	0	18.8	12.8
				40	18.8	12.8
				100	18.8	12.8
				160	18.8	12.8
				220	14.8	12.8
				280	11.8	5.8
				340	8	-
			Vertical	0	3.8	-
				40	3.8	-
				100	3.8	-
				160	3.8	-
				220	2.8	-
				280	1.3	-
340	-			-		
12	Horizontal	0	12.8	8.8		
		80	12.8	8.8		
		200	12.8	8.8		
		320	12.8	8.8		
		440	9	5		
		560	5	0.5		
		680	2	-		

[When high-output setting for motor straight type double slider specification is ineffective]

Type	Motor Type	Lead [mm]	Horizontal/ Vertical	Payload by Acceleration/Deceleration [kg]		
				Velocity [mm/s]	0.3G	0.7G
SA7C	56P	4	Horizontal	0	38.3	28.3
				35	38.3	28.3
				70	38.3	28.3
				105	35	25
				140	10	1
			Vertical	0	13.3	-
				35	13.3	-
				70	13.3	-
				105	3	-
				140	-	-
		8	Horizontal	0	38.3	23.3
				70	38.3	23.3
				140	38.3	23.3
				210	20	9
				280	5	-
			Vertical	0	8.3	-
				70	8.3	-
				140	5.3	-
				210	-	-
				280	-	-
16	Horizontal	0	33.3	18.3		
		140	33.3	18.3		
		280	23.3	10.3		
		420	10	1		
		560	2	-		

(Note) High-output settings are not available in SA8C or SA8R that operate with the PCON-CFB controller.

[When high-output setting for side-mounted type double slider specification is ineffective]

Type	Motor Type	Lead [mm]	Horizontal/ Vertical	Payload by Acceleration/Deceleration [kg]		
				Velocity [mm/s]	0.3G	0.7G
SA4R	35P	2.5	Horizontal	0	11.4	11.4
				20	11.4	11.4
				40	11.4	11.4
				65	11.4	10.4
				85	10.4	9.4
				105	9.4	8.4
				130	8	6
			Vertical	0	8.4	-
				20	8.4	-
				40	8.4	-
				65	7.4	-
				85	7.4	-
				105	7.4	-
				130	3	-
		5	Horizontal	0	11.4	9.4
				40	11.4	9.4
				85	11.4	9.4
				130	9.4	8.4
				175	9.4	7.4
				215	8.4	6.4
				260	6	4
			Vertical	0	3.9	-
				40	3.9	-
				85	3.9	-
				130	3.4	-
				175	3.4	-
				215	3.4	-
10	Horizontal	0	9.4	7.4		
		85	9.4	7.4		
		175	9.4	7.4		
		260	8.4	5.4		
		350	6.4	4.4		
		435	4	2		
		525	3	1		

[When high-output setting for side-mounted type double slider specification is ineffective]

Type	Motor Type	Lead [mm]	Horizontal/ Vertical	Payload by Acceleration/Deceleration [kg]		
				Velocity [mm/s]	0.3G	0.7G
SA6R	42P	3	Horizontal	0	23.8	20.8
				20	23.8	20.8
				50	23.8	20.8
				80	23.8	20.8
				110	18.8	12.8
				140	13.8	9.8
				170	9	7
			Vertical	0	8.8	-
				20	8.8	-
				50	8.8	-
				80	8.8	-
				110	6.8	-
				140	3.8	-
				170	-	-
		6	Horizontal	0	18.8	12.8
				40	18.8	12.8
				100	18.8	12.8
				160	18.8	12.8
				220	14.8	12.8
				280	11.8	5.8
				340	8	-
			Vertical	0	3.8	-
				40	3.8	-
				100	3.8	-
				160	3.8	-
				220	2.8	-
				280	1.3	-
340	-			-		
12	Horizontal	0	12.8	8.8		
		80	12.8	8.8		
		200	12.8	8.8		
		320	12.8	8.8		
		440	9	5		
		560	5	0.5		
		680	2	-		

[When high-output setting for side-mounted type double slider specification is ineffective]

Type	Motor Type	Lead [mm]	Horizontal/ Vertical	Payload by Acceleration/Deceleration [kg]		
				Velocity [mm/s]	0.3G	0.7G
SA7R	56P	4	Horizontal	0	38.3	28.3
				35	38.3	28.3
				70	38.3	28.3
				105	35	25
				140	10	1
			Vertical	0	13.3	-
				35	13.3	-
				70	13.3	-
				105	3	-
				140	-	-
		8	Horizontal	0	38.3	23.3
				70	38.3	23.3
				140	38.3	23.3
				210	20	9
				280	5	-
			Vertical	0	8.3	-
				70	8.3	-
				140	5.3	-
				210	-	-
				280	-	-
		16	Horizontal	0	33.3	18.3
				140	33.3	18.3
				280	23.3	10.3
				420	10	1
560	2			-		

 **Caution:** Do not attempt to establish the settings for the acceleration/deceleration above the allowable range. It may cause a vibration, malfunction or shorten the product life. If any acceleration/deceleration equal to or greater than the rated acceleration/deceleration is set, a creep phenomenon or slipped coupling may occur.

1.2.4 Driving System • Position Detector

Type	Motor Type	Lead	No. of Encoder Pulses	Ball Screw Type		
				Type	Diameter	Accuracy
SA4C SA4R	35P	2.5	8192	Rolled	φ8mm	C10
		5				
		10				
		16				
SA6C SA6R	42P	3		Rolled	φ10mm	C10
		6				
		12				
		20				
SA7C SA7R	56P	4		Rolled	φ12mm	C10
		8				
		16				
		24				
SA8C SA8R	56SP	5		Rolled	φ16mm	C10
		10				
		20				
		30				

1.2.5 Positioning Precision

Type	Lead	Item	Tolerance	
			Standard	High Precision Specification Optional Model: HPR
SA4C	2.5, 5, 10	Positioning repeatability	±0.01mm	±0.005mm
		Lost motion	0.1mm or less	0.1mm or less
	16	Positioning repeatability	±0.01mm	-
		Lost motion	0.1mm or less	-
SA4R	2.5, 5, 10, 16	Positioning repeatability	±0.01mm	-
		Lost motion	0.1mm or less	-
SA6C	3, 6, 12	Positioning repeatability	±0.01mm	±0.005mm
		Lost motion	0.1mm or less	0.1mm or less
	20	Positioning repeatability	±0.01mm	-
		Lost motion	0.1mm or less	-
SA6R	3, 6, 12, 20	Positioning repeatability	±0.01mm	-
		Lost motion	0.1mm or less	-
SA7C	4, 8	Positioning repeatability	±0.01mm	±0.005mm
		Lost motion	0.1mm or less	0.1mm or less
	16, 24	Positioning repeatability	±0.01mm	-
		Lost motion	0.1mm or less	-
SA7R	4, 8, 16, 24	Positioning repeatability	±0.01mm	-
		Lost motion	0.1mm or less	-
SA8C	5, 10	Positioning repeatability	±0.01mm	±0.005mm
		Lost motion	0.1mm or less	0.1mm or less
	20, 30	Positioning repeatability	±0.01mm	-
		Lost motion	0.1mm or less	-
SA8R	5, 10, 20, 30	Positioning repeatability	±0.01mm	-
		Lost motion	0.1mm or less	-

This is an option already attached when it is shipped out from the factory. It does not include the consideration of time-dependent change as it is used.

1.2.6 Current Limit Value and Pressing Force

●SA4C, SA4R

Current Limit Value	Lead 2.5 [N]	Lead 5 [N]	Lead 10 [N]	Lead 16 [N]
20%	89	44	22	-
30%	133	66	33	21
40%	177	89	44	27
50%	221	111	55	34
60%	266	133	66	41
70%	310	155	77	48

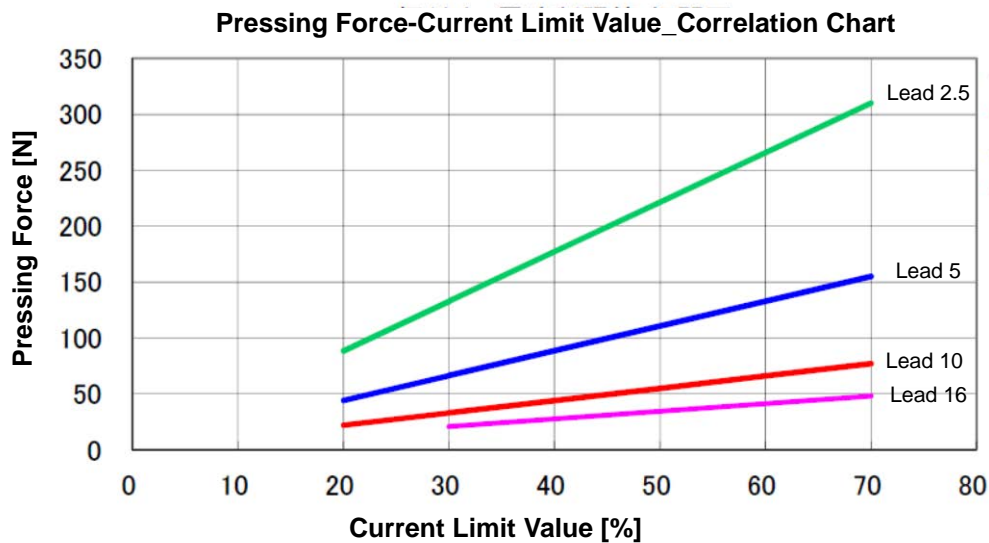

- ⚠ Caution:**
- (1) The relation of the current limit and the pressing force is a reference when assuming the speed is 20mm/s.
 - (2) There is a little variance in the actual pressing force. The variance of the pressing force becomes large when the current limit value is low.
 - (3) Use the product within the range in the graph for the current limit value. Pressing force will not be stable if used below 20%. There is even a case that it would not operate. An operation cannot be made also when it is beyond 70%. Doing so may cause degradation in the motor coil insulation by heat radiation, which results in shortening the product life.
 - (4) For CON-system controllers such as PCON, when the approach speed to the pressing start position (setting in the position table) is 20mm/s or less, pressing will be performed with the approach speed. In such a case also the pressing force will be unstable. In such cases, check in advance that the actuator can be used with no problem before omit using.
For SEL-system controllers, such as MSEL, press at the speed set by PAPR instruction, regardless of the approach speed up to the pressing start position.

●SA6C, SA6R,

Current Limit Value	Lead 3 [N]	Lead 6 [N]	Lead 12 [N]	Lead 20 [N]
20%	106	53	27	16
30%	159	79	40	24
40%	211	106	53	32
50%	264	132	66	40
60%	317	159	80	48
70%	370	185	93	56

※ This is a reference at 20mm/s of pressing speed.

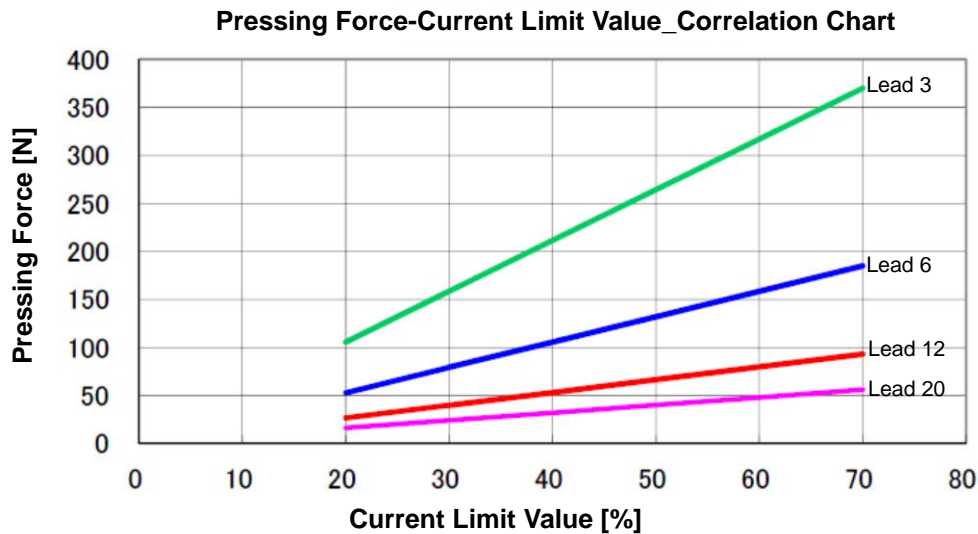

- ⚠ Caution:
- (1) The relation of the current limit and the pressing force is a reference when assuming the speed is 20mm/s.
 - (2) There will be a little variance in the actual pressing force. The variance of the pressing force becomes large when the current limit value is low.
 - (3) Use the product within the range in the graph for the current limit value. Pressing force will not be stable if used below 20%. There is even a case that it would not operate. An operation cannot be made also when it is beyond 70%. Doing so may cause degradation in the motor coil insulation by heat radiation, which results in shortening the product life.
 - (4) For CON-system controllers such as PCON, when the approach speed to the pressing start position (setting in the position table) is 20mm/s or less, pressing will be performed with the approach speed. In such a case also the pressing force will be unstable. In such cases, check in advance that the actuator can be used with no problem before omit using.
For SEL-system controllers, such as MSEL, press at the speed set by PAPER instruction, regardless of the approach speed up to the pressing start position.

•SA7C, SA7R

Current Limit Value	Lead 4 [N]	Lead 8 [N]	Lead 16 [N]	Lead 24 [N]
20%	192	96	48	32
30%	288	144	72	48
40%	385	192	96	64
50%	481	240	120	80
60%	577	288	144	96
70%	673	336	168	112

※ This is a reference at 20mm/s of pressing speed.

Pressing Force-Current Limit Value_Correlation Chart

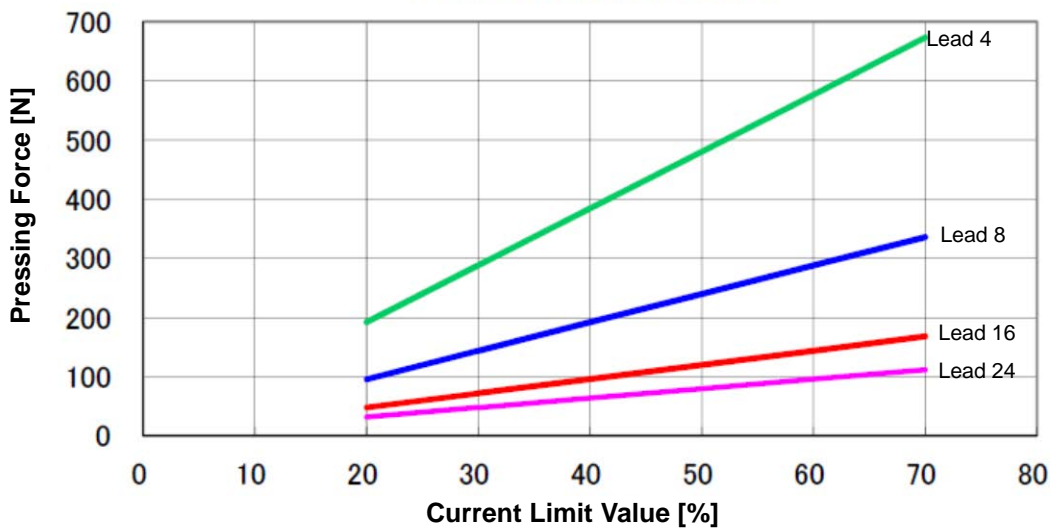

- ⚠ Caution:
- (1) The relation of the current limit and the pressing force is a reference when assuming the speed is 20mm/s.
 - (2) There will be a little variance in the actual pressing force. The variance of the pressing force becomes large when the current limit value is low.
 - (3) Use the product within the range in the graph for the current limit value. Pressing force will not be stable if used below 20%. There is even a case that it would not operate. An operation cannot be made also when it is beyond 70%. Doing so may cause degradation in the motor coil insulation by heat radiation, which results in shortening the product life.
 - (4) For CON-system controllers such as PCON, when the approach speed to the pressing start position (setting in the position table) is 20mm/s or less, pressing will be performed with the approach speed. In such a case also the pressing force will be unstable. In such cases, check in advance that the actuator can be used with no problem before omit using.
For SEL-system controllers, such as MSEL, press at the speed set by PAPR instruction, regardless of the approach speed up to the pressing start position.

●SA8C, SA8R

Current Limit Value	Lead 5 [N]	Lead 10 [N]	Lead 20 [N]	Lead 30 [N]
20%	273	137	68	46
30%	410	205	102	68
40%	546	273	137	91
50%	683	341	171	114
60%	819	410	205	137
70%	956	478	239	159

※ This is a reference at 20mm/s of pressing speed.

Pressing Force-Current Limit Value_Correlation Chart

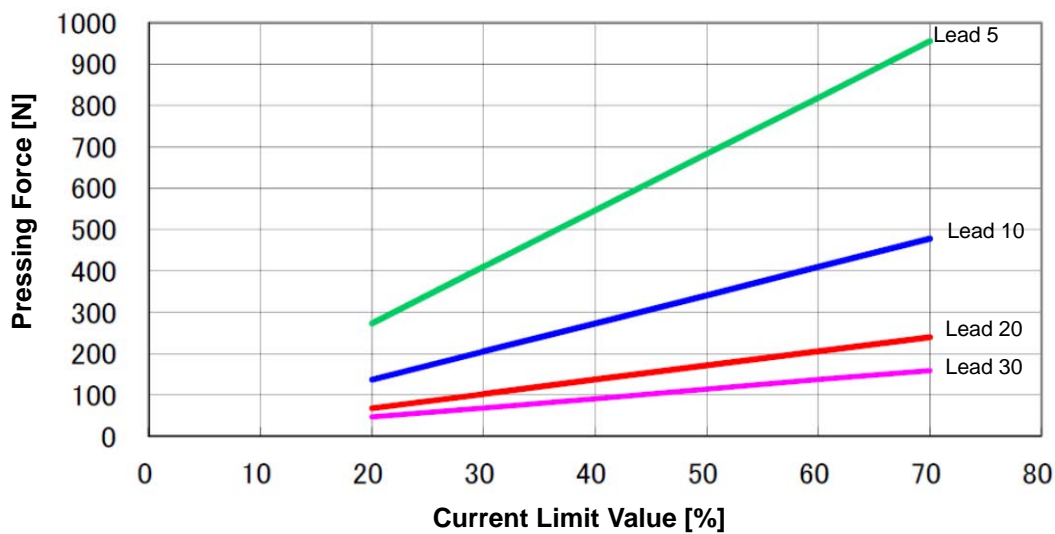

- ⚠ Caution:
- (1) The relation of the current limit and the pressing force is a reference when assuming the speed is 20mm/s.
 - (2) There will be a little variance in the actual pressing force. The variance of the pressing force becomes large when the current limit value is low.
 - (3) Use the product within the range in the graph for the current limit value. Pressing force will not be stable if used below 20%. There is even a case that it would not operate. An operation cannot be made also when it is beyond 70%. Doing so may cause degradation in the motor coil insulation by heat radiation, which results in shortening the product life.
 - (4) For CON-system controllers such as PCON, when the approach speed to the pressing start position (setting in the position table) is 20mm/s or less, pressing will be performed with the approach speed. In such a case also the pressing force will be unstable. In such cases, check in advance that the actuator can be used with no problem before omit using.
For SEL-system controllers, such as MSEL, press at the speed set by PAPR instruction, regardless of the approach speed up to the pressing start position.

1.2.7 Allowable Moment of Actuator

[Single Slider]

Type	Allowable static moment [N·m]			Allowable dynamic moment [N·m]			Allowable overhang Load (L)
	Ma	Mb	Mc	Ma	Mb	Mc	
SA4C SA4R	13.0	18.6	25.3	5.0	7.1	9.7	Ma direction: 150mm Mb or Mc direction: 150mm
SA6C SA6R	48.5	69.3	103	11.6	16.6	24.6	Ma direction: 220mm Mb or Mc direction: 220mm
SA7C SA7R	115	115	229	44.7	44.7	89.1	Ma direction: 300mm Mb or Mc direction: 300mm
SA8C SA8R	219	219	414	77.0	77.0	146	Ma direction: 400mm Mb or Mc direction: 400mm

Allowable dynamic moment is a moment in the case of the operation life of 5,000 km. [Refer to 6. "Life"]

[Double Slider (Option)]

Type	Real Span of Slider [mm]	Allowable Static Moment [N·m]			Allowable Dynamic Moment [N·m]			Allowable Overhang Load (L)
		Ma	Mb	Mc	Ma	Mb	Mc	
SA4C SA4R	60	143	204	50.5	44.6	63.6	15.7	Ma direction: 420mm Mb or Mc direction: 420mm
SA6C SA6R	90	546	779	205	106	152	40	Ma direction: 630mm Mb or Mc direction: 630mm
SA7C SA7R	70	900	900	458	285	285	145	Ma direction: 810mm Mb or Mc direction: 810mm
SA8C SA8R	120	1980	1980	828	565	565	237	Ma direction: 1,200mm Mb or Mc direction: 1,200mm

Allowable dynamic moment is a moment in the case of the operation life of 5,000 km. [Refer to 6. "Life"]

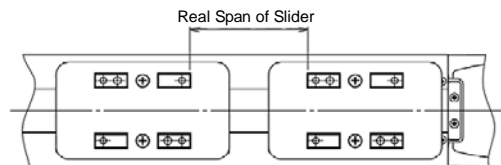

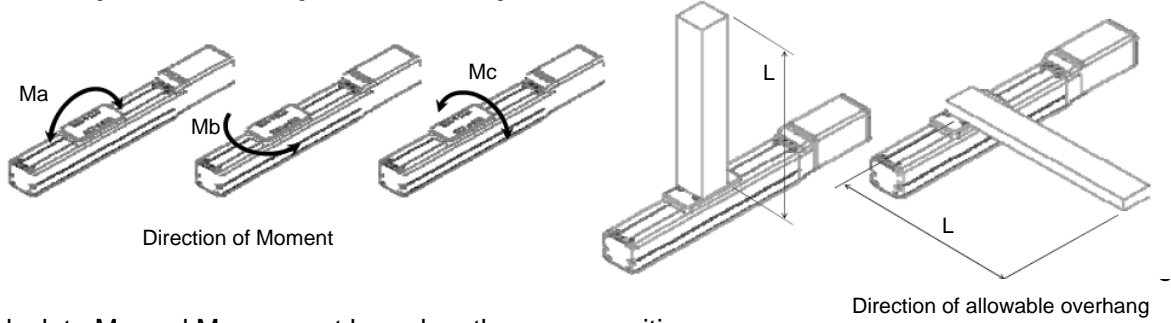

[For the dimensions of the slide cover and the dimensions between the slide covers, please refer to 5. "External Dimensions"]

Ma: Pitching direction Mb: Yawing direction Mc: Rolling direction

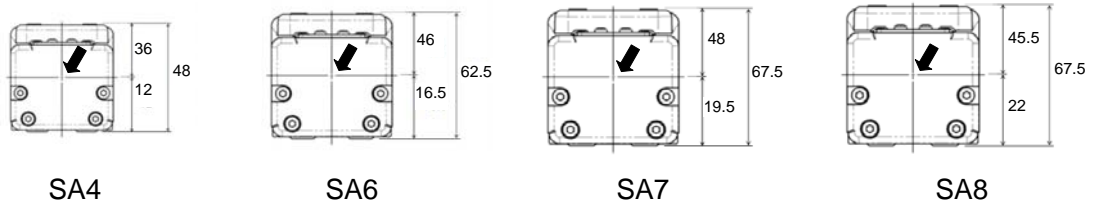

Calculate Ma and Mc moment based on the arrow position.



 **Note:** If the actuator is used with exceeding allowable moment and overhang load, it would not only cause noise and vibration, but also it may significantly reduce the life of the actuator.

1.2.8 Duty ratio for continuous operation

[Standard Specification]

It can operate continuously when the duty ratio is 100%.

[Built-in Controller Specification]

© RCP6S-SA4C, 4R, 8C, 8R, RCP6SCR-SA4C, 8C

It can operate continuously when the duty ratio is 100%.

© RCP6S-SA6C, 6R, RCP6SCR-SA6C

Lead 12mm and 20mm can operate continuously when the duty ratio is 100%.

Operate with the duty ratio as in the following graph for lead 3mm and 6mm.

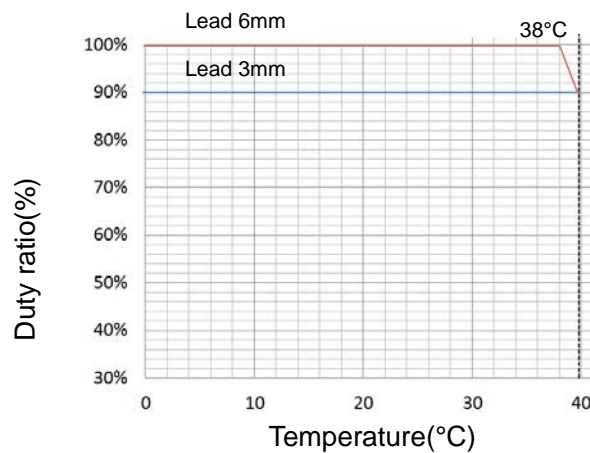

© RCP6S-SA7C, 7R, RCP6SCR-SA7C

Lead 24mm can operate continuously when the duty ratio is 100%.

Operate with the duty ratio as in the following graph for lead 4mm, 8mm, and 16mm.

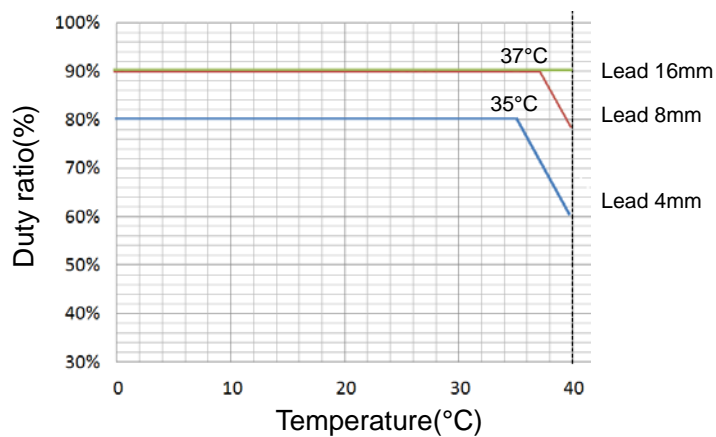

Duty ratio is an operating rate, which indicates the time that the actuator is running in one cycle by percentage.

1.3 Options

1.3.1 Brake Type (Model : B)

The brake is a mechanism designed to prevent the slider from dropping on a vertically installed actuator when the power or servo is turned OFF.

Use the brake to prevent the installed load, etc., from being damaged due to the falling slider.

1.3.2 Reversed-home Specification (Model : NM)

The standard home position is on the motor side. However, the motor position will be reversed if it is desirable in view of the layout of the system, etc.

(Note) The home position is adjusted at the factory before shipment. If you wish to change the home after the delivery of your actuator, you must return the actuator to IAI for adjustment.

1.3.3 High Precision Specifications (Model: HPR)

Application: SA4C lead 2.5, 5, 10

SA6C lead 3, 6, 12

SA7C lead 4, 8

SA8C lead 5, 10

(However, the double slider specification W is excluded.)

Standard positioning repeatability is $\pm 0.01\text{mm}$. When this option is specified, positioning repeatability will become $\pm 0.005\text{mm}$.

There are some leads that cannot be set. [Refer to 1.2.4 "Positioning Precision"]

1.3.4 Motor Left Side-Mounted, Motor Right Side-Mounted (Model: ML, MR)

From the view of the motor side, the type with the motor side-mounted to the left is ML and the motor side-mounted to the right is MR.

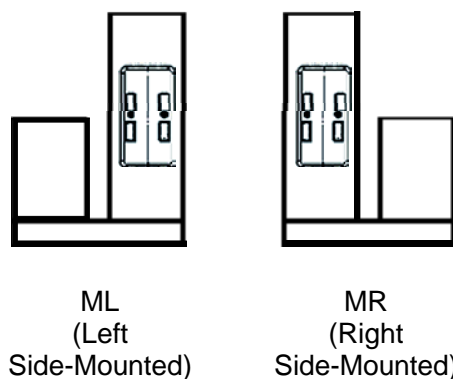

1.3.5 Cable Exit Direction Changed (Model: CJT, CJR, CJL, CJB, CJO)

If a change in the cable exit direction is made, the direction of cable exit will be changed. There are ejection directions, top (model: CJT), right (model: CJR), left (model: CJL), bottom (model: CJB) and outward (model: CJO). The side-mounted motor type of RA4S, RA6S, RA7S, and RA8S can only be selected for CJO.

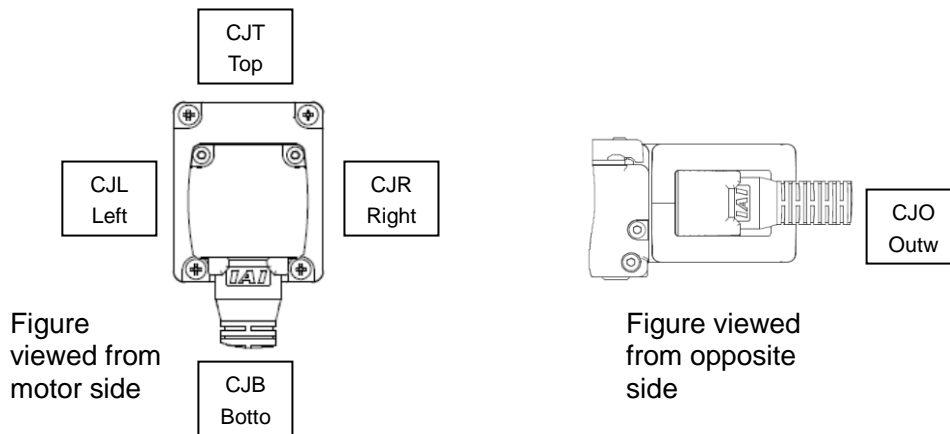

1.3.6 Slider spacer (Model: SS)

Application : SA7R, SA8R(However, the double slider specification W is excluded.)
 When the spacer is used, the work mounting surface of the slider can be higher than the motor unit. This allows to ignore work interferences.
 [For the shapes, refer to 5. "External Dimensions"]

1.3.7 Slider Roller Specification (Model: SR)

The structure of the slider is a roller structure, the same as the cleanroom type.

1.3.8 Double Slider Specification (Model: W)

This is an option that adds a free slider that is not connected to the ball screw. Doubling the slider makes it possible to increase the moment and the overhang load length.
 [For the shapes, refer to 5. "External Dimensions"]

1.3.9 Air Vacuum Joint on the Opposite Side (Model: VR)

The air vacuum joint of the cleanroom type is standardly installed on the left side of the actuator as viewed from the motor side. This is an actuator in which this joint is installed on the opposite side.

1.4 Motor • Encoder Cables

1.4.1 Motor • Encoder Integrated Cables (SA4, SA6 and SA7)

CB-CAN-MPA□□□

□□□ indicates the cable length (L) (Example: 030=3m), Max.20m

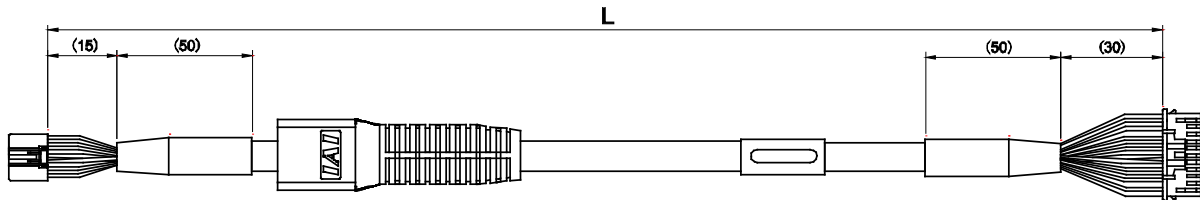

Actuator side

Connector: DF62B-24S-2.2C
Contact: DF62-2428SCFA (For AWG26)
DF62-22SCFA (For AWG22)

Controller side

Connector: PADP-24V-1-S
Contact: SPND-002T-C0.5 (For AWG26)
SPND-001T-C0.5 (For AWG22)

Connection diagram

Actuator side				Controller side			
Thickness	Electric Wire Color	Symbol	Pin No.	Pin No.	Symbol	Electric Wire Color	Thickness
AWG22/19	Blue	ϕ A	3	1	ϕ A	Blue	AWG22/19
AWG22/19	Orange	VMM	5	2	VMM	Orange	AWG22/19
AWG22/19	Brown	ϕ B	10	3	ϕ B	Brown	AWG22/19
AWG22/19	Gray	VMM	9	4	VMM	Gray	AWG22/19
AWG22/19	Green	ϕ _A	4	5	ϕ _A	Green	AWG22/19
AWG22/19	Red	ϕ _B	15	6	ϕ _B	Red	AWG22/19
AWG26	Black	LS+	8	7	LS+	Black	AWG26
AWG26	Yellow	LS-	14	8	LS-	Yellow	AWG26
AWG26	Blue	SA	12	11	SA	Blue	AWG26
AWG26	Orange	SB	17	12	SB	Orange	AWG26
AWG26	Green	A+	1	13	A+	Green	AWG26
AWG26	Brown	A-	6	14	A-	Brown	AWG26
AWG26	Gray	B+	11	15	B+	Gray	AWG26
AWG26	Red	B-	16	16	B-	Red	AWG26
AWG26	Blue	BK+	20	9	BK+	Blue	AWG26
AWG26	Orange	BK-	2	10	BK-	Orange	AWG26
AWG26	Gray	VCC	21	17	VCC	Gray	AWG26
AWG26	Red	GND	7	19	GND	Red	AWG26
AWG26	Brown	VPS	18	18	VPS	Brown	AWG26
AWG26	Green	LS_GND	13	20	LS_GND	Green	AWG26
-	-	-	19	22	-	-	-
AWG26	Pink	-	22	21	-	Pink	AWG26
-	-	-	23	23	-	-	-
AWG26	Black	FG	24	24	FG	Black	AWG26

(Note) About thickness AWG22/19

The thickness is AWG22 when the cable length is 5m or less, and AWG19 when longer than 5m.

1.4.2 Motor • Encoder Integrated Cables Robot Type (SA4, SA6 and SA7)

CB-CAN-MPA□□□-RB

□□□ indicates the cable length (L) (Example: 030=3m), Max.20m

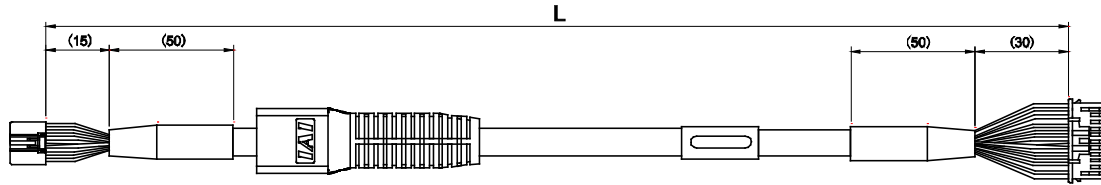

Actuator side

Connector: DF62B-24S-2.2C
Contact: DF62-2428SCFA (For AWG26)
DF62-22SCFA (For AWG22)

Controller side

Connector: PADP-24V-1-S
Contact: SPND-002T-C0.5 (For AWG26)
SPND-001T-C0.5 (For AWG22)

Connection diagram

Actuator side				Controller side			
Thickness	Electric Wire Color	Symbol	Pin No.	Pin No.	Symbol	Electric Wire Color	Thickness
AWG22/19	Blue	ϕ A	3	1	ϕ A	Blue	AWG22/19
AWG22/19	Orange	VMM	5	2	VMM	Orange	AWG22/19
AWG22/19	Brown	ϕ B	10	3	ϕ B	Brown	AWG22/19
AWG22/19	Gray	VMM	9	4	VMM	Gray	AWG22/19
AWG22/19	Green	ϕ _A	4	5	ϕ _A	Green	AWG22/19
AWG22/19	Red	ϕ _B	15	6	ϕ _B	Red	AWG22/19
AWG26	Black	LS+	8	7	LS+	Black	AWG26
AWG26	Yellow	LS-	14	8	LS-	Yellow	AWG26
AWG26	Blue	SA	12	11	SA	Blue	AWG26
AWG26	Orange	SB	17	12	SB	Orange	AWG26
AWG26	Green	A+	1	13	A+	Green	AWG26
AWG26	Brown	A-	6	14	A-	Brown	AWG26
AWG26	Gray	B+	11	15	B+	Gray	AWG26
AWG26	Red	B-	16	16	B-	Red	AWG26
AWG26	Blue	BK+	20	9	BK+	Blue	AWG26
AWG26	Orange	BK-	2	10	BK-	Orange	AWG26
AWG26	Gray	VCC	21	17	VCC	Gray	AWG26
AWG26	Red	GND	7	19	GND	Red	AWG26
AWG26	Brown	VPS	18	18	VPS	Brown	AWG26
AWG26	Green	LS_GND	13	20	LS_GND	Green	AWG26
-	-	-	19	22	-	-	-
AWG26	Pink	-	22	21	-	Pink	AWG26
-	-	-	23	23	-	-	-
AWG26	Black	FG	24	24	FG	Black	AWG26

(Note) About thickness AWG22/19

The thickness is AWG22 when the cable length is 5m or less, and AWG19 when longer than 5m.

1.4.3 Motor • Encoder Integrated Cables (SA8)

CB-CFA3-MPA□□□

□□□ indicates the cable length (L) (Example: 030=3m), Max.20m

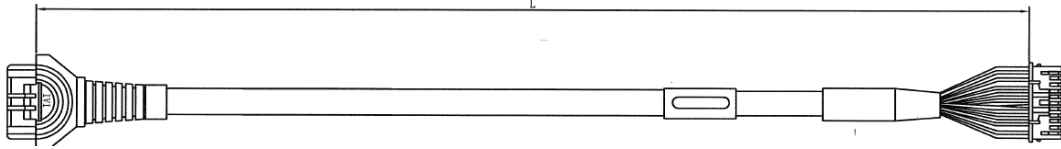

Actuator side

Connector: 1-1827863-1
Contact: 1827570-2

Controller side

Connector: PADP-24V-1-S
Contact: SPND-002T-C0.5 (For AWG26)
SPND-001T-C0.5 (For AWG22)

Connection diagram

Actuator side				Controller side			
Thickness	Electric Wire Color	Symbol	Pin No.	Pin No.	Symbol	Electric Wire Color	Thickness
AWG22/19	Blue	ϕ A	A1	1	ϕ A	Blue	AWG22/19
AWG22/19	Orange	VMM	B1	2	VMM	Orange	AWG22/19
AWG22/19	Green	ϕ _A	A2	5	ϕ _A	Green	AWG22/19
AWG22/19	Brown	ϕ B	B2	3	ϕ B	Brown	AWG22/19
AWG22/19	Gray	VMM	A3	4	VMM	Gray	AWG22/19
AWG22/19	Red	ϕ _B	B3	6	ϕ _B	Red	AWG22/19
AWG26	Black	LS+	A4	7	LS+	Black	AWG26
AWG26	Yellow	LS-	B4	8	LS-	Yellow	AWG26
AWG26	Blue	SA	A6	11	SA	Blue	AWG26
AWG26	Orange	SB	B6	12	SB	Orange	AWG26
AWG26	Green	A+	A7	13	A+	Green	AWG26
AWG26	Brown	A-	B7	14	A-	Brown	AWG26
AWG26	Gray	B+	A8	15	B+	Gray	AWG26
AWG26	Red	B-	B8	16	B-	Red	AWG26
AWG26	Blue	BK+	A5	9	BK+	Blue	AWG26
AWG26	Orange	BK-	B5	10	BK-	Orange	AWG26
AWG26	Green	LS_GND	A9	20	LS_GND	Green	AWG26
AWG26	Brown	VPS	B9	18	VPS	Brown	AWG26
AWG26	Gray	VCC	A10	21	VCC	Gray	AWG26
AWG26	Red	GND	B10	19	GND	Red	AWG26
-	-	-	A11	17	-	-	-
AWG26	Black	FG	B11	22	-	-	AWG26
				23	-	-	-
				24	FG	Black	AWG26

(Note) About thickness AWG22/19

The thickness is AWG22 when the cable length is 5m or less, and AWG19 when longer than 5m.

1.4.4 Motor • Encoder Integrated Cables Robot Type (SA8)

CB-CFA3-MPA□□□-RB

□□□ indicates the cable length (L) (Example: 030=3m), Max.20m

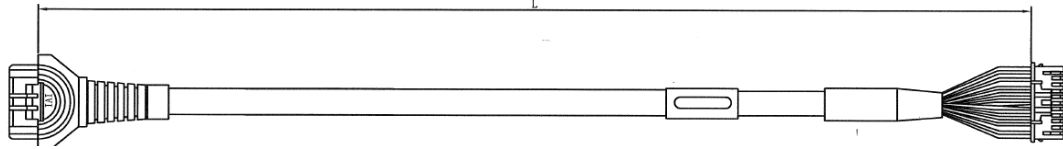

Actuator side

Connector: 1-1827863-1
Contact: 1827570-2

Controller side

Connector: PADP-24V-1-S
Contact: SPND-002T-C0.5 (For AWG26)
SPND-001T-C0.5 (For AWG22)

Connection diagram

Actuator side				Controller side			
Thickness	Electric Wire Color	Symbol	Pin No.	Pin No.	Symbol	Electric Wire Color	Thickness
AWG22/19	Blue	ϕ A	A1	1	ϕ A	Blue	AWG22/19
AWG22/19	Orange	VMM	B1	2	VMM	Orange	AWG22/19
AWG22/19	Green	ϕ _A	A2	5	ϕ _A	Green	AWG22/19
AWG22/19	Brown	ϕ B	B2	3	ϕ B	Brown	AWG22/19
AWG22/19	Gray	VMM	A3	4	VMM	Gray	AWG22/19
AWG22/19	Red	ϕ _B	B3	6	ϕ _B	Red	AWG22/19
AWG26	Black	LS+	A4	7	LS+	Black	AWG26
AWG26	Yellow	LS-	B4	8	LS-	Yellow	AWG26
AWG26	Blue	SA	A6	11	SA	Blue	AWG26
AWG26	Orange	SB	B6	12	SB	Orange	AWG26
AWG26	Green	A+	A7	13	A+	Green	AWG26
AWG26	Brown	A-	B7	14	A-	Brown	AWG26
AWG26	Gray	B+	A8	15	B+	Gray	AWG26
AWG26	Red	B-	B8	16	B-	Red	AWG26
AWG26	Blue	BK+	A5	9	BK+	Blue	AWG26
AWG26	Orange	BK-	B5	10	BK-	Orange	AWG26
AWG26	Green	LS_GND	A9	20	LS_GND	Green	AWG26
AWG26	Brown	VPS	B9	18	VPS	Brown	AWG26
AWG26	Gray	VCC	A10	21	VCC	Gray	AWG26
AWG26	Red	GND	B10	19	GND	Red	AWG26
-	-	-	A11	17	-	-	-
AWG26	Black	FG	B11	22	-	-	AWG26
				23	-	-	-
				24	FG	Black	AWG26

(Note) About thickness AWG22/19

The thickness is AWG22 when the cable length is 5m or less, and AWG19 when longer than 5m.



2. Installation

2.1 Transportation

[1] Handling of Robot

When you want to transport the actuator alone, observe the following points.

(1) Handling the Packed Unit

Unless otherwise specified, the actuator is shipped with each axis packaged separately.

- Do not damage or drop. The package is not applied with any special treatment that enables it to resist an impact caused by a drop or crash.
- Transport a heavy package with at least more than two operators. Consider an appropriate method for transportation.
- Keep the unit in horizontal orientation when placing it on the ground or transporting. Follow the instruction if there is any for the packaging condition.
- Do not step or sit on the package.
- Do not put any load that may cause a deformation or breakage of the package.

(2) Handling the Actuator After Unpacking

- Do not carry an actuator by motor unit and a cable or attempt to move it by pulling the cable.
- Be careful not to bump the actuator into anything when moving it.
- Hold the body base when transporting the actuator.
- Do not apply an excessive force to each part of the actuator.
In the case that the actuator has a stainless steel sheet, take particular care not to apply pressure to the stainless steel sheet.

 Note: Never hold the stainless steel sheet part.

Supplement) For the names of each part of the actuator, refer to “Names of the Parts”

[2] Handling in the Assembled Condition

This is the case when the product is delivered from our factory under a condition that it is assembled with other actuators. The combined axes are delivered in a package that the frame is nailed on the lumber base. Fix the slider so that would not accidentally move during transportation. The actuators are also fixed so the tip of it would not shake due to the external vibration.

(1) Handling the Packed Unit

- Do not damage or drop. The package is not applied with any special treatment that enables it to resist an impact caused by a drop or crash.
- Do not attempt to carry a heavy package with only one worker. Also, have an appropriate method for transportation.
- When hanging up with ropes, support on the reinforcement frame on the bottom of the lumber base. When bringing up the package with a forklift, also support on the bottom of the lumber base.
- Handle with care when putting the package down to avoid impact or bounce.
- Do not step on the package.
- Do not put any load that may cause a deformation or breakage of the package.

(2) How to Handle after Unpackaged

- Fix the slider so they would not accidentally move during transportation.
- If the tip of an actuator is overhanging, have an appropriate way to fix it to avoid shake due to the external vibration. In the transportation without the tip being fixed, do not apply any impact with 0.3G or more.
- When hanging up with ropes, have appropriate cushioning to avoid any deformation of the actuator body. Also keep it in stable horizontal orientation. Make a fixture utilizing the attachment holes and the tapped holes on the actuator body if necessary.
- Do not attempt to apply load on the actuators or the connector box. Also pay attention not to pinch cables and bend or deform them forcefully.

[3] Handling in Condition of being assembled in Machinery Equipment (System)

These are some caution notes for when transporting the actuator being assembled in the machinery equipment (system):

- Fix the slider so they would not accidentally move during transportation.
- If the tip of an actuator is overhanging, have an appropriate way to fix it to avoid shake due to the external vibration. In the transportation without the tip being fixed, do not apply any impact with 0.3G or more.
- When hanging up the machinery equipment (system) with ropes, do not attempt to apply load on the actuators or the connector box. Also pay attention not to pinch cables and bend or deform them forcefully.

2.2 Installation and Storage • Preservation Environment

[1] Installation Environment

The actuator should be installed in a location other than those specified below.

In general, the installation environment should be one in which an operator can work without protective gear.

Also provide sufficient work space required for maintenance inspection.

- Where the actuator receives radiant heat from strong heat sources such as heat treatment furnaces
- Where the ambient temperature exceeds the range of 0 to 40°C
- Where the temperature changes rapidly and condensation occurs
- Where the relative humidity exceeds 85% RH
- Where the actuator receives direct sunlight
- Where the actuator is exposed to corrosive or combustible gases
- Where the ambient air contains a large amount of powder dust, salt or iron (at level exceeding what is normally expected in an assembly plant)
- Where the actuator is subject to splashed water, oil (including oil mist or cutting fluid) or chemical solutions
- Where the actuator receives impact or vibration
- Where the altitude is more than 2000m

If the actuator is used in any of the following locations, provide sufficient shielding measures:

- Where noise generates due to static electricity, etc.
- Where the actuator is subject to a strong electric or magnetic field
- Where the actuator is subject to ultraviolet ray or radiation

[2] Storage • Preservation Environment

- The storage and preservation environment should comply with the same standards as those for the installation environment. In particular, when the machine is to be stored for a long time, pay close attention to environmental conditions so that no dew condensation forms.
- Unless specially specified, moisture absorbency protection is not included in the package when the machine is delivered. In the case that the machine is to be stored and preserved in an environment where dew condensation is anticipated, take the condensation preventive measures from outside of the entire package, or directly after opening the package.
- For storage and preservation temperature, the machine withstands temperatures up to 60°C for a short time, but in the case of the storage and preservation period of 1 month or more, control the temperature to 50°C or less.
- Storage and preservation should be performed in the horizontal condition. In the case it is stored in the packaged condition, follow the posture instruction if any displayed on the package.

2.3 How to Install

This chapter explains how to install the actuator on your mechanical system.





2.3.1 Installation

Follow the information below when installing the actuator, as a rule. Do pay attention to these items (except with custom-order models).

○ : Possible △ : Daily inspection is required × : Not possible

Model	Horizontal installation	Vertical installation	Sideway installation	Ceiling mount installation
SA4C, SA6C, SA7C, SA8C, SA4R, SA6R, SA7R, SA8R	○	○	△	△

Installation Orientation

Horizontal	Vertical	Sideways	Ceiling mount
			

- ⚠ Caution:**
- When the unit is installed vertically oriented, Motor straight type is attempt to put the motor up unless there is a special reason. · Putting the motor on the lower side would not cause a problem in an ordinary operation. However, it may rarely cause a problem, when it is not operated for a long period, depending on the surrounding environment (especially high temperature), caused by the grease being separated and the base oil flowing into the motor unit.
 - Can be installed sideways or ceiling mount, but the actuators must be checked daily. If the actuator is installed sideways or ceiling mount, the stainless steel sheet may be slacked or displaced. If the actuator is used continuously while the stainless steel sheet is slacked or displaced, the stainless steel sheet may break or other problems may occur. Check the actuator daily and if the stainless steel sheet is found slacked or displaced, make installation adjustment of the stainless steel sheet. [Refer to 4.7 “Procedure for Stainless Steel Sheet Replacement and Adjustment”]

2.3.2 Installation of the Main Unit

The surface to mount the main unit should be a machined surface or a plane that possesses an equivalent accuracy and the flatness should be within 0.05mm/m. Also, the platform should have a structure stiff enough to install the unit so it would not generate vibration or other abnormality.

Also consider enough space necessary for maintenance work such as actuator replacement and inspection.

There are reference surfaces for attachment on the base.

The flatness of the slider movement is designed to be 0.05mm/m at maximum to the reference surface.

On the rear side of the actuator, there are tapped holes and through holes for attachment and reamed hole and oblong hole for positioning. See the appearance drawings for the details of the position and diameters. [Refer to 5. "External Dimensions"]

Utilize the reamed holes when repeatability in the attachment after detaching is required. However, when small tunings such as the perpendicularity is required, consider such things like to use one reamed hole.

[1] Using the Tapped Holes on the Bottom of the Base

This actuator has the tapped holes for mounting so it can be fixed from the bottom of the base. (Note that tapped hole size depends on the model. Please see the diagrams below and 5 "External Dimensions".)

Also, there are reamed holes and an oblong hole for positioning pins.

(Note) Strokes 50 for SA6, SA7, and strokes 50 and 100 for SA8 do not have oblong holes.

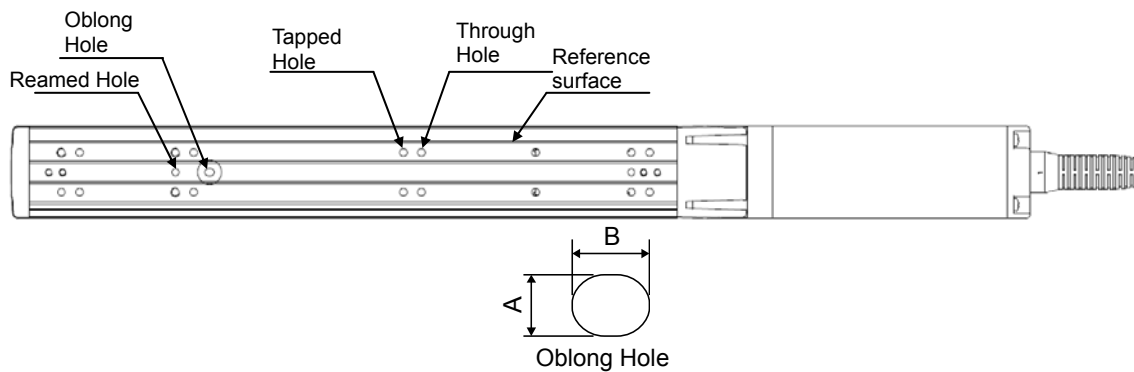

Model Name	Tapped Hole Size	Tapped Holes Depth	Tightening Torque		Reamed Hole [mm]	Oblong Hole
			In the case that steel is used for the bolt seating surface:	In the case that aluminum is used for the bolt seating surface:		
SA4C SA4R	M4	Through (screwing depth should be 6mm max.)	3.59N·m (0.37kgf·m)	1.76N·m (0.18kgf·m)	φ3H7 Depth 4	A:3 ^{+0.010} ₀ B:4 Depth 4mm or less
SA6C SA6R	M5	Through (screwing depth should be 10mm max.)	7.27N·m (0.74kgf·m)	3.42N·m (0.35kgf·m)	φ4H7 Depth 5.5	A:4 ^{+0.010} ₀ B:5 Depth 5.5mm or less
SA7C SA7R	M5	Through (screwing depth should be 10mm max.)	7.27N·m (0.74kgf·m)	3.42N·m (0.35kgf·m)	φ4H7 Depth 6	A:4 ^{+0.010} ₀ B:5 Depth 6mm or less
SA8C SA8R	M6	Through (screwing depth should be 12mm max.)	12.3N·m (1.25kgf·m)	5.4N·m (0.55kgf·m)	φ6H7 Depth 6.5	A:6 ^{+0.010} ₀ B:7 Depth 6.5mm or less

Tightening Screws

- Use hexagonal socket head bolts for the male threads for installing the base.
- Use of high-tension bolts meeting at least ISO 10.9 is recommended.
- The length of thread engagement should be 1.8 times more than the nominal diameter, and pay attention not to stick the screw out inside the actuator for through hole.



Note: Be careful when selecting the bolt length. If bolts of inappropriate lengths are used, the tapped holes may be damaged, actuator mounting strength may become insufficient, or contact with driving parts may occur, resulting in lower precision or unexpected accidents.

[2] Using the Through Holes on the Top of the Base

There are through holes equipped on the base of SA4, SA6, SA7, so the unit can be attached from the top of the base.

Detach the side covers on the sides when installing.

(Remove 4 attachment screws (+) with a Philips screwdriver.)

Attempt not to drop the bolts, tools, etc. on the stainless steel sheet when tightening the bolts.

Please avoid making a dent mark or scratches.

The slider cannot be driven only with ROBO Cylinder itself if it is equipped with a brake.

Detach the motor unit once to move the slider for installation, and put the motor unit back on.

[Refer to 4.9 “Motor Replacement Process”]

Or, connect a controller and have JOG operation to move the slider to perform installation.

(Note) For the side-mounted specification models of SA4R, SA6R, and SA7R, the side cover and motor cover interfere each other so that they cannot be removed as they are. Remove the motor cover and detach the side cover.

[For removing direction of the motor cover, refer to 4.9 “Motor Replacement Process”]

For mounting bolts, use hexagonal socket head bolts indicated in the following table depending on the platform material.

Model Name	Through Hole	Mounting Bolt	Tightening Torque
SA4C SA4R	φ3.4 drilled hole, 6.5 counter boring depth 3.5	M3	0.83N·m (0.085kgf·m)
SA6C SA6R	φ4.5 drilled hole, 8 counter boring depth 4.5	M4	1.76N·m (0.18kgf·m)
SA7C SA7R	φ6 drilled hole, 9.5 counter boring depth 5.5	M5	3.42N·m (0.35kgf·m)

Tightening Screws

- Use hexagonal socket head bolts for the male threads for installing the base.
- Use of high-tension bolts meeting at least ISO 10.9 is recommended.
- For the effective engagement length between the bolt and female thread, provide at least the applicable value specified below:
 Female thread is made of steel material → Same length as the nominal diameter
 Female thread is made of aluminum → 1.8 times of nominal diameter

 **Note:** Be careful when selecting the bolt length. If bolts of inappropriate lengths are used, actuator mounting strength may become insufficient, or contact with driving parts may occur, resulting in lower precision or unexpected accidents.

[3] When Using Attachment Holes on Bracket in Side-Mounted Motor Type

There are tapped holes equipped on the side-mounted bracket. (Refer to the table below for detailed dimensions.)

- For SA4R

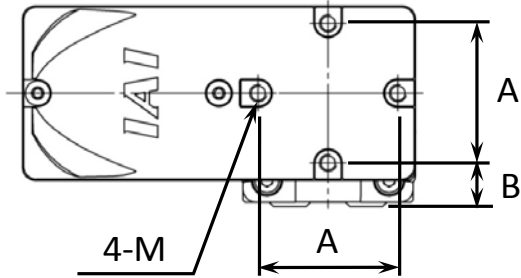

- For SA6R, SA7R, SA8R

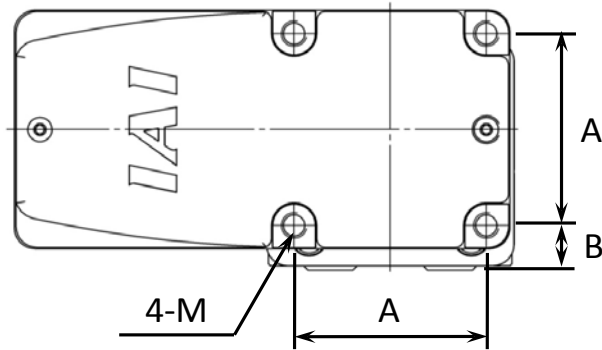

	A	B
SA4R	32	10
SA6R	45	10.5
SA7R	55	8
SA8R	55	9.5

Model Name	Attachment Hole Diameter	Attachment Hole Depth	Tightening Torque
SA4R	M4	8mm	1.76N·m (0.18kgf·m)
SA6R	M6	12mm	5.4N·m (0.55kgf·m)
SA7R	M8	16mm	11.5N·m (1.17kgf·m)
SA8R	M8	16mm	11.5N·m (1.17kgf·m)

Tightening Screws

- Use hexagonal socket head bolts for the male threads for installing the base.
- Use of high-tension bolts meeting at least ISO 10.9 is recommended.
- Have the length of thread engagement approximately 1.8 times of the nominal diameter.



Note: Be careful when selecting the bolt length. If bolts of inappropriate lengths are used, the damage of the attachment hole and actuator mounting strength may become insufficient, or contact with driving parts may occur, resulting in lower precision or unexpected accidents.

[Precautions for Attachments]

Pay attention to the following when installation is conducted with using the attachment holes on the side-mounted bracket.

Do not attempt to affix the unit only with the tapped holes on the side-mounted bracket.

Do not apply external force to the main body.

There may be caused vibration due to the operating condition or installation environment, which may result in operational failures or components malfunction.

Availability of installation for each installation posture is as shown below:

Installation Posture			Support
Horizontal	Vertical	Ceiling Mount	
x	x	x	No
o	o	x	Yes

When using the product in horizontal or vertical orientation, have a support block to support the main body to avoid any external force to be applied on the body.

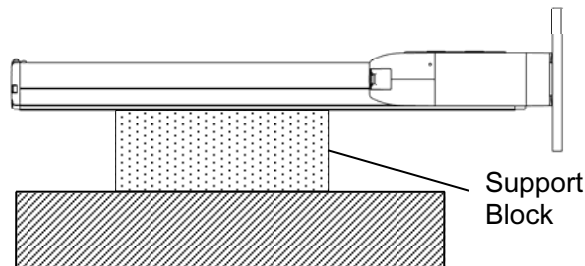

[4] Attachment of Transported Object

- There are tapped holes on the top surface of the slider.
- The way to affix follows the installation of the main unit.
- There are two reamed holes on the top surface of the slider. Use these reamed holes if repeatability of attaching and detaching is required. Also, if small tuning such as perpendicularity is required, use one of the reamed holes for the tuning.
- Refer to the below table for the screwed depth and reamed depth. Screwing further than indicated in the table may destroy the tapped hole or lower the reinforcement of the attachment of the work part, result in the drop of the accuracy or an unexpected accident.

- For SA4C/R, SA6C/R, SA7C/R

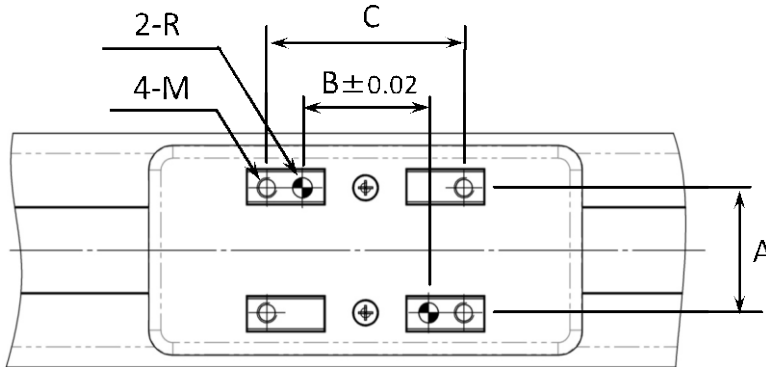

Pitch tolerance from reamer ± 0.02

- For SA8C/R

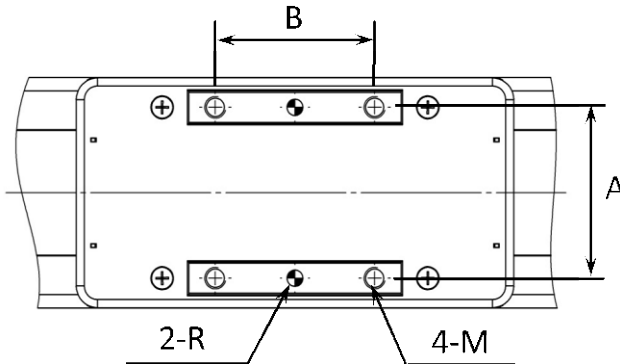

Pitch tolerance from reamer ± 0.02

Model Name	A	B	C	Reamed Hole	Tapped Hole M	Mounting Bolt	
						Bolt Nominal Diameter	Tightening Torque
SA4C, SA4R	20	24	32	$\phi 3H7$ Depth 6	M3 Depth 7	M3	0.83N·m (0.085Kgf·m)
SA6C, SA6R	31	32	50	$\phi 5H7$ Depth 6	M5 Depth 10	M5	3.42N·m (0.35Kgf·m)
SA7C, SA7R	39	42	65	$\phi 5H7$ Depth 10	M5 Depth 10	M5	3.42N·m (0.35Kgf·m)
SA8C, SA8R	63	60	/	$\phi 6H7$ Depth 10	Through M8 (screwing depth should be 12mm max.)	M8	11.5N·m (1.17Kgf·m)

Tightening Screws

- Use hexagonal socket head bolts for the male threads for installing the base.
- Use of high-tension bolts meeting at least ISO 10.9 is recommended.
- Have the length of thread engagement approximately 1.8 times of the nominal diameter.

 Note: Be careful when selecting the bolt length. Selection of inappropriate length of bolts may cause a breakage of tapped holes or insufficient strength of attachment for transportation.

[5] Mounting Surface

- The platform to install the actuator should possess a structure that ensures enough stiffness, and should be free from vibration.
- The surface where the actuator will be mounted should be a machined surface or that with an accuracy equivalent to it, and the flatness should be 0.05mm/m or below.
- Ensure a room for maintenance work.
- The side and bottom surfaces of the base on the actuator work as the reference surfaces for the side of the slider.
- Use these surfaces as the reference surfaces for mounting.

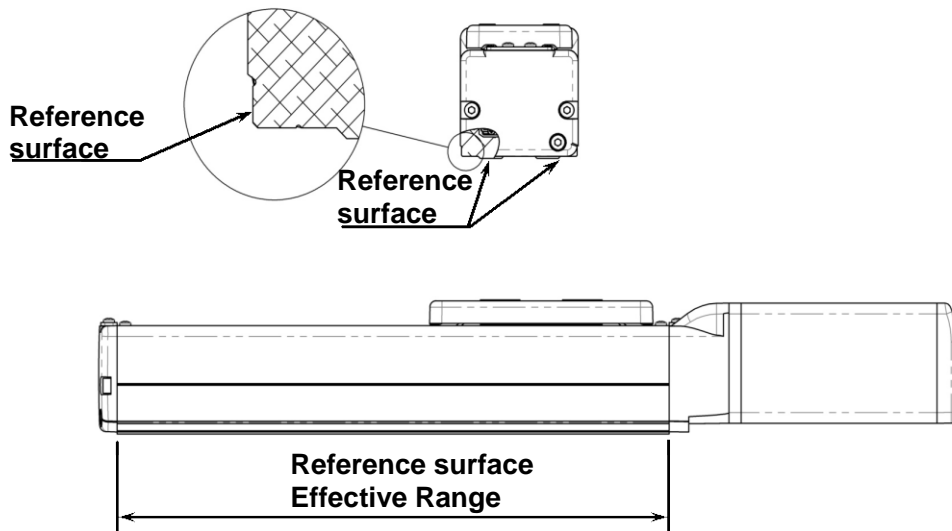

In the case that the accuracy is required, use the base side surface as reference surface for mounting, as this surface works as the reference surface for the running of the slider.

Follow the below when installing the device using the reference surface.

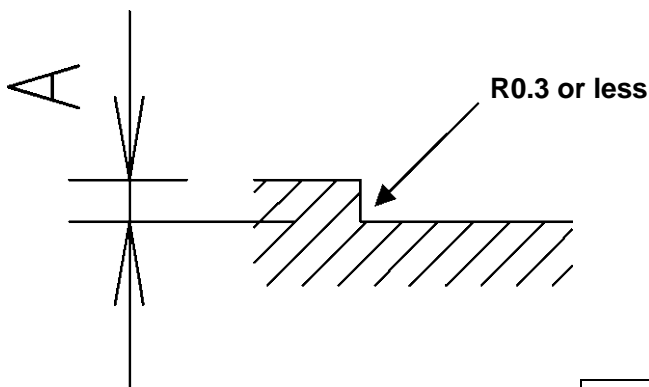

Model Name	A Dimensions [mm]
SA4, SA6, SA7	2 to 4 or less
SA8	3 to 5 or less

Note: There are cases that the width dimensions of the front bracket and rear bracket are bigger than the width dimensions of the reference surface, so it must be abutted within the effective range of the reference surface.

If given an abutting on reference surface process outside of the effective range, it may interfere with the bracket and the motor unit.

2.3.3 About Suction of the CleanroomType

Cleanroom type actuators are able to exert performance corresponding to cleanroom class 10 (0.1 μm , Fed.Std.209D) and class 2.5 equivalent (ISO 14644-1) by aspirating air from the vacuum joint. The guidelines of the suction amounts for the rated speeds of each model are shown in the following table.

- Please perform suction of air from the two vacuum joints located on the sides of the actuator according to the suction amounts (total amount of the two locations) shown in the table below. Also, please manage the joints so that the suction amounts of the two locations are equivalent.
- Please use the actuator in a state in which all of the base attachment holes on the bottom of the actuator are covered. When there is a hole that passes through the actuator, the level of cleanliness decreases.

[Suction amount guideline]

Single slider specification

Model Number	Lead [mm]	Suction Amount NI/min (L/min)
RCP6(S)CR-SA4C	2.5	10 (11)
	5	20 (22)
	10	40 (43)
	16	60 (65)
RCP6(S)CR-SA6C	3	15 (16)
	6	30 (32)
	12	70 (76)
	20	100 (108)
RCP6(S)CR-SA7C	4	30 (32)
	8	40 (43)
	16	70 (76)
	24	90 (97)
RCP6(S)CR-SA8C	5	30 (32)
	10	60 (65)
	20	110 (119)
	30	160 (173)

Double slider specification (option model W)

Model Number	Lead [mm]	Suction Amount NI/min (L/min)
RCP6(S)CR-SA4C	2.5	20 (22)
	5	30 (32)
	10	60 (65)
RCP6(S)CR-SA6C	3	35 (38)
	6	60 (65)
	12	110 (119)
RCP6(S)CR-SA7C	4	40 (43)
	8	50 (54)
	16	100 (108)
RCP6(S)CR-SA8C	5	40 (43)
	10	90 (97)
	20	170 (183)

3. Connecting with the Controller

As the connection cable for the controller and the actuator, use the IAI-dedicated connection cable.

- If the dedicated connection cable cannot be secured, reduce the load on the cable by allowing it to deflect only by the weight of the cable or wire it in a self-standing cable hose, etc., having a large radius.
- Do not cut and reconnect the dedicated connection cable for extension or shorten the cable.
- Do not pull on the dedicated connection cable or bend it forcibly.
- The actuator cable coming out of the motor unit is not meant to be bent. Fix the cable so it would not be bent repeatedly

Please consult with IAI if you require a different kind of cable than the one supplied.

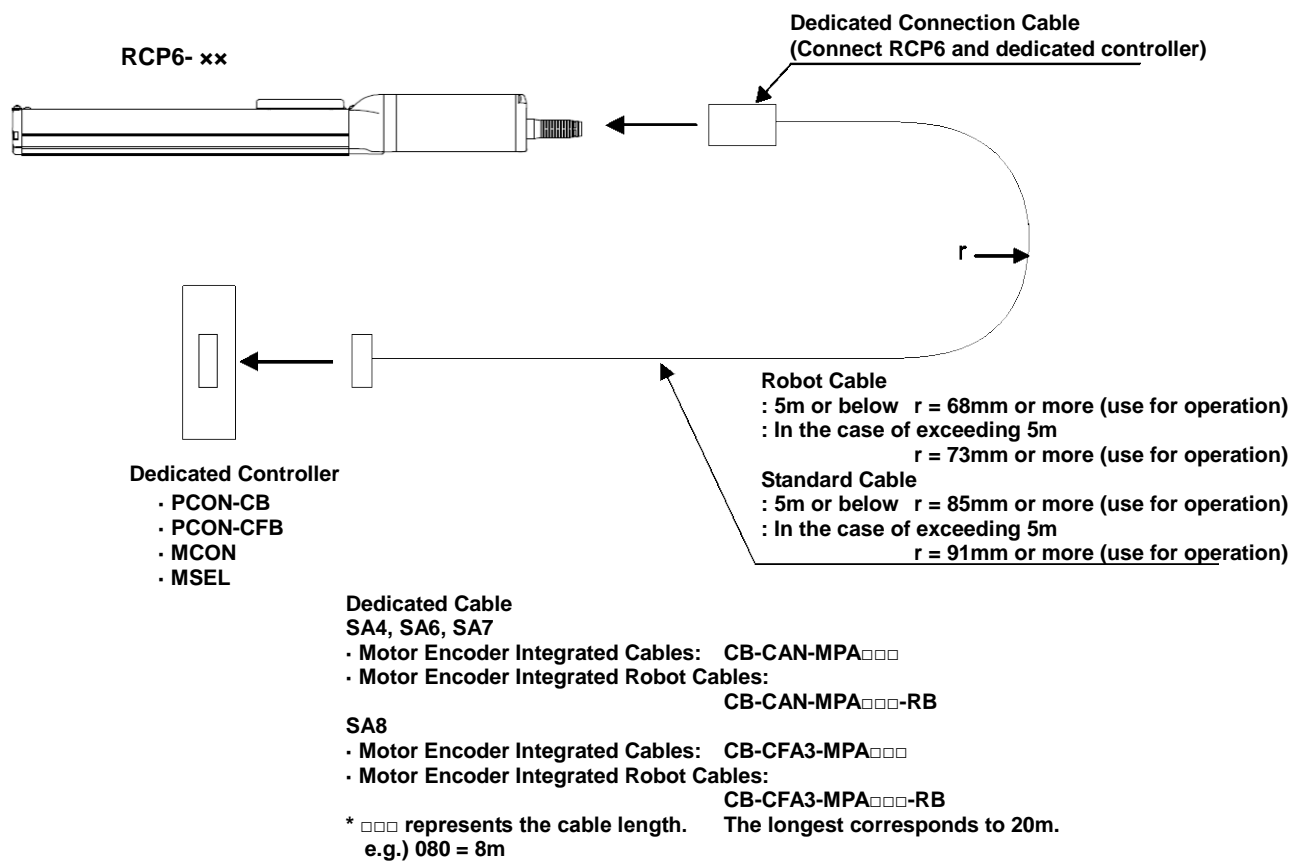

Warning: For wiring, please follow the warnings stated below. When constructing a system as the machinery equipment, pay attention to the wiring and connection of each cable so they are conducted properly. Not following them may cause not only a malfunction such as cable breakage or connection failure, or an operation error, but also electric shock or electric leakage, or may even cause a fire.

- Use dedicated cables of IAI indicated in this instruction manual. Contact us if you wish to have a change to the specifications of the dedicated cables.
- Make sure to turn the power off in the process of power line or cable connection or disconnection.
- Do not attempt to cut a dedicated cable with connectors on both ends to extend, shorten or re-joint it.
- Hold the dedicated cable to avoid mechanical force being applied to the terminals and connectors.
- Use a cable pipe or duct to have an appropriate protection when there is a possibility of mechanical damage on a dedicated cable.
- In case a dedicated cable is to be used at a moving part, make sure to lay out the cable without applying any force to pull the connector or extreme bend on the cable. Do not attempt to use the cable with a bending radius below the allowable value.
- Make certain that the connectors are plugged properly. Insufficient connection may cause an operation error, thus it is extremely risky.
- Do not lay out the cables to where the machine runs over them.
- Pay attention to the cable layout so it would not hit peripherals during an operation. In case it does, have an appropriate protection such as a cable track.
- When a cable is used hanging on the ceiling, prevent an environment that the cable swings with acceleration or wind velocity.
- Make sure there is not too much friction inside the cable storage equipment.
- Do not apply radiated heat to power line or cables.
- Do not bend the cable in the area from the connector tip inward to 150mm on both ends.

Motor • Encoder Integrated Cables

CB-CAN-MPA□□□

CB-CFA3-MPA□□□

Motor • Encoder Integrated Cables Robot Type

CB-CAN-MPA□□□-RB

CB-CFA3-MPA□□□-RB

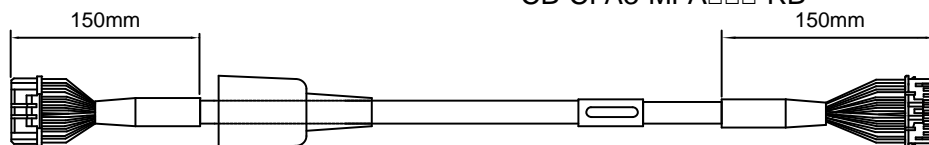

- Have a sufficient radius for bending, and avoid a bend concentrating on one point.

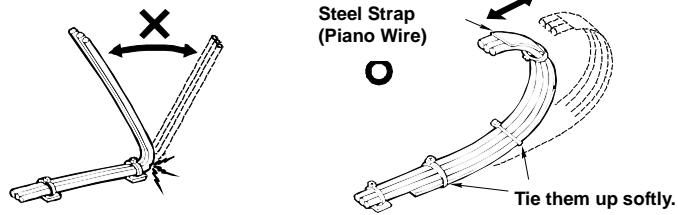

- Do not let the cable bend, kink or twist.

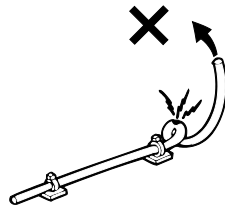

- Do not pull the cable with a strong force.

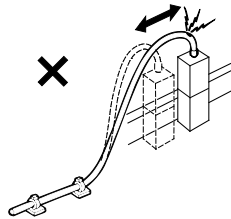

- Pay attention not to concentrate the twisting force to one point on a cable.

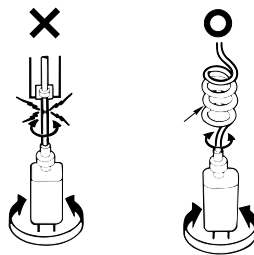

- Do not pinch, drop a heavy object onto or cut the cable.

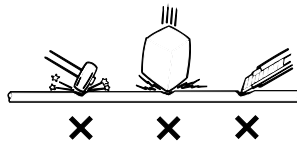

- When a cable is fastened to affix, make sure to have an appropriate force and do not tighten too much.

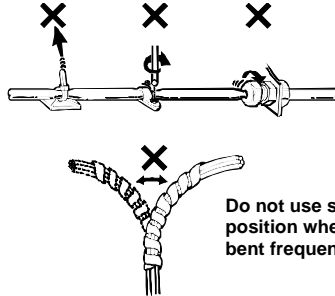

- PIO line, communication line, power and driving lines are to be put separately from each other and do not tie them together. Arrange so that such lines are independently routed in the duct.

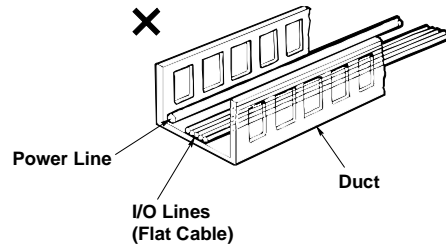

Follow the instructions below when using a cable track.

- If there is an indication to the cable for the space factor in a cable track, refer to the wiring instruction given by the supplier when storing the cable in the cable track.
- Avoid the cables to get twined or twisted in the cable track, and also to have the cables move freely and do not tie them up. (Avoid tension being applied when the cables are bent.) Do not pile up cables. It may cause faster abrasion of the sheaths or cable breakage.

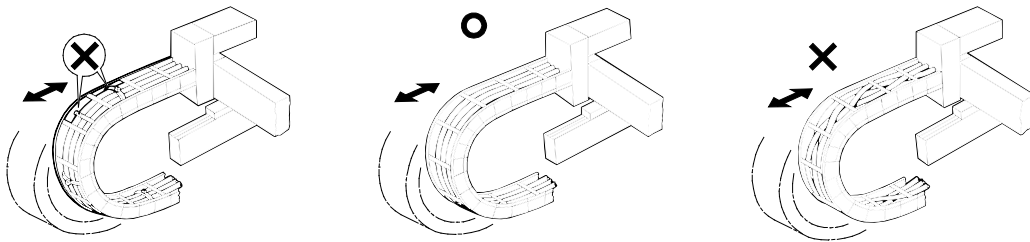

4. Maintenance and Inspection

4.1 Inspection Items and Schedule

Follow the maintenance inspection schedule below.

It is assumed that the equipment is operating 8 hours per day.

If the equipment is running continuously night and day or otherwise running at a high operating rate, inspect more often as needed.

Period of Time	External Visual Inspection	Internal Inspection	Greasing ^(Note 1)
Start of work inspection	○		
1 month inspection	○		
3 month inspection			○
3 months after starting operation			Depends on grease supply timing (reference)
6 month inspection	○	○ ^(Note 2)	
Every 6 months thereafter	○	○ ^(Note 2)	

Note 1 Grease film may run out if the actuator is moved back and forth continuously over a distance of 30 mm or less. As a guide, perform a back-and-forth operation five times or so over a distance of 50 mm or more after a back-and-forth operation over such short distance has been repeated 5,000 to 10,000 times. This will restore oil film.

Note 2 Check the condition of grease, and wipe off the grease before supplying new in case it is extremely dirty.

[Grease Supply Timing (Reference)]

Perform grease supply when it has reached to either the operation distance or spent months described in the table below.

Maximum Speed of Use [mm/s]	Grease Supply Timing (Reference)	
	Operated distance	Months
0 to 750 or less	1,250km	12 month
750 to 1440	2,500km	

4.2 External Visual Inspection

An external visual inspection should check the following things.

Main unit	Loose actuator mounting bolts, other loose items
Cables	Scratches, proper connections
Stainless steel sheet	Scratches, displacement, slack
Overall	Abnormal noise, vibration

- In the case that displacement or slack of stainless steel sheet is found, timely adjust it.
- As a rule of thumb, the stainless steel sheet should last for about 5000km of slider motion. However, depending on the usage, replace the stainless steel sheet appropriately. Generally, replacing the stainless steel sheet will require that you bring the unit to our plant or have one of our technicians come to your plant to perform the replacement.
- If the actuator is installed vertically, certain conditions may cause grease to drip from the guide. Please ensure that proper cleaning is performed and grease is replenished.

4.3 Cleaning

- Clean exterior surfaces as necessary.
- Use a soft cloth to wipe away dirt and buildup.
- Do not blow too hard with compressed air as it may cause dust to get in through the gaps.
- Do not use oil-based solvents as they can harm lacquered and painted surfaces.
- To remove severe buildup, wipe gently with a soft cloth soaked in a neutral detergent or alcohol.

4.4 Internal Inspections

Turn OFF the power, remove the side cover and have a visual inspection. When inspecting the interior, check the following items.

Actuator	Loose mounting bolts, other loose items
Guide section	Lubrication, buildup

Visually inspect the interior of the equipment. Check whether dust or other foreign matter has gotten inside and check the lubrication state.

The lubrication may have turned brown. This is not a problem as long as the travel surfaces shine as though they are wet.

If the grease is mixed with dust and does not have a shiny appearance, or if the grease has lost its efficacy due to prolonged use, then clean each section and reapply grease.

The procedure for internal inspections is outlined below.

- ① Loosen the screws on the side cover and detach the side cover.
- ② Check inside.
- ③ After finishing the inspection, assemble back in the reverse order. If you touch the edge of the stainless steel sheet in the attaching the side cover process, the sheet may get damaged or wavy which result in shortening life or earlier wear-out.
To avoid touching the edge of the sheet, insert a spacer (approximately 0.1 to 0.2mm) between the sheet and cover to push up the sheet, and then push in the cover.

When affixing the side cover, tighten the screws with the tightening torque described below.

Screw Diameter	Tightening Torque
M5	41.4N·cm

- ④ Make sure that the slider and the side cover do not interfere, moving the slider backwards and forwards between the strokes.

 **Note:** Do not damage the stainless steel sheet by bending it forcefully during internal inspection.
Do not tug on the stainless steel sheet or in any way attempt to reposition it. Change in the attached condition may cause the sheet to be mounted unevenly or impact the product life. In such cases, please contact IAI Sales Engineer Department.
Keep in mind that the edges of the stainless steel sheet can cause injuries. Always wear gloves when working on it.

4.5 Internal Cleaning

- Use a soft cloth to wipe away dirt and buildup.
- Do not blow too hard with compressed air as it may cause dust to get in through the gaps.
- Do not use oil-based solvents, neutral detergent or alcohol.

4.6 Grease Supply

4.6.1 Standard Type Grease to Use

[1] Standard Type

IAI uses the following grease in our plant.

Guide Ball Screw	Kyodo Yushi	Multitemp LRL 3
---------------------	-------------	-----------------



Warning: Never use anything other than synthetic poly-olefin grease. Mixing poly-grease with other grease not only reduces the performance of the grease, it may even cause damage to the actuator.

[2] Cleanroom Type

For the cleanroom type, urea-based grease having superior low-dust emission, stable torque characteristics, superior lubricity, and antirust effects equivalent to lithium-based grease is used. IAI uses the following grease in our plant.

Guide/Ball Screw	Kuroda Precision Industries	C grease
------------------	-----------------------------------	----------



Warning:

- For grease to be used with an actuator that has a cleanroom setting, please use a type of grease that emits a low amount of dust and is described for cleanroom use. When standard grease is used, dust may be emitted.
- Never use anything other than synthetic poly-olefin grease. When other types of grease are mixed with urea-based grease, degradation of the original lubricity may result in damage to the actuator or the clean performance may degrade.

4.6.2 How to Apply Grease

- 1) Remove the screw and detach the side cover on either side, right or left.
The grease nipple will appear.
(Note) When the side cover on the other side has been detached, the other grease nipple also appears.

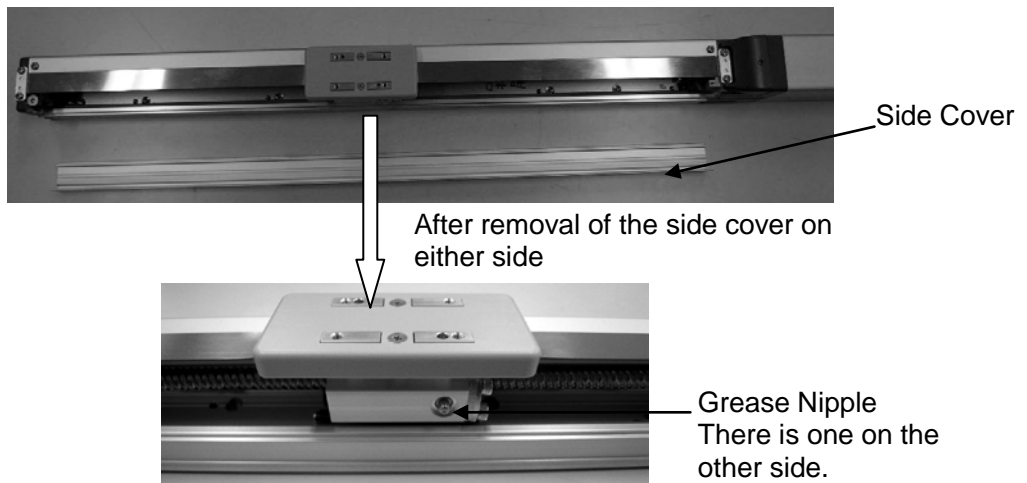
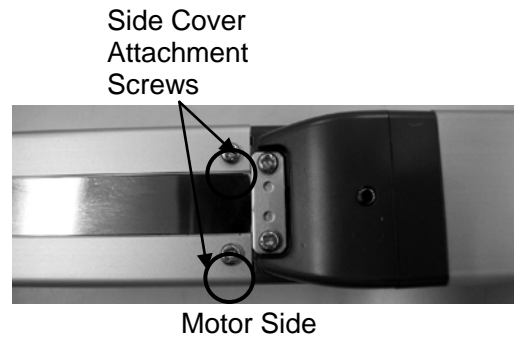
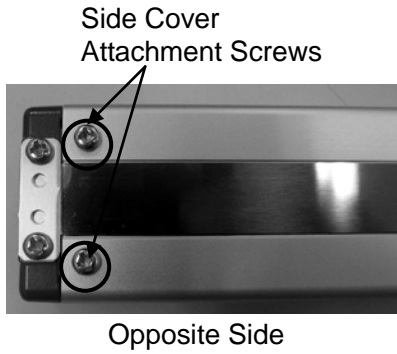

- 2) Supply grease from the grease nipple on either side, using the grease gun.
 Wipe off the grease before supplying new in case it is extremely dirty.
 (Note) Grease can also be applied from the grease nipple on the other side.
 When grease is applied from the grease nipple on either side, grease is supplied to the ball screw and the guides on both sides.

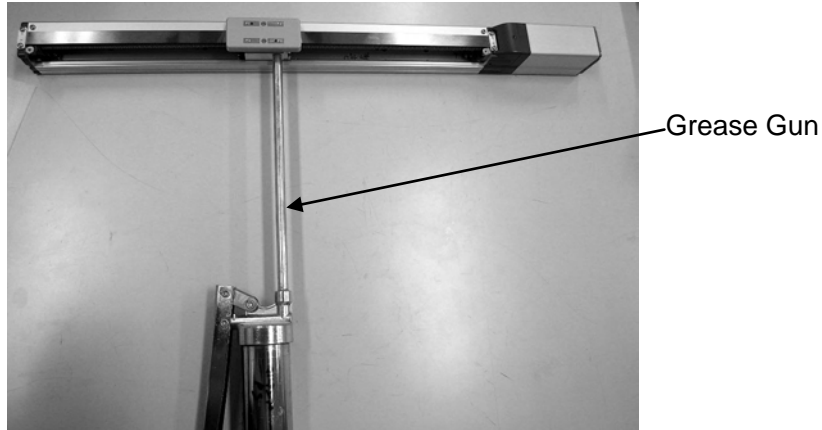

(Note) Make sure to use a grease gun that is applicable for the grease nipple inlet diameter shown below.

Grease Nipple Diameter
φ3.5

Recommended Grease Gun	Nozzle	Supplier
HGP	NZ3	NSK

Model	Amount of Grease Supply (Reference)
SA4	0.5cc to 1.0cc
SA6, SA7	1.5cc to 2.0cc

Move the slider back and forth in the stroke range after supplying grease so it spreads out evenly in the area.

- Confirm that the ball tracks on the ball screw and guide look glossy with oil of grease. Supply grease again if it is not spread enough.
- Wipe off excess grease.

⚠ Caution: Supplying too much grease may increase sliding resistance and load to the motor, resulting in a drop of performance. Also, excess grease on the ball screw may be splashed around in the ambience.

- 3) Attach the side covers after grease supply is finished.
If you touch the edge of the stainless steel sheet in the attaching process, the sheet may get damaged or wavy which result in shortening life or earlier wear-out.
To avoid touching the edge of the sheet, insert a spacer (approximately 0.1 to 0.2mm) between the sheet and cover to push up the sheet, and then push in the cover.
Also, make sure to follow the notice of caution when attaching side covers described in the next page when side covers are attached.

When affixing the side cover, tighten the screws with the tightening torque described below.

Screw Diameter	Tightening Torque
M3	41.4N·cm

- 3) Make sure that the slider and the side cover do not interfere, moving the slider backwards and forwards between the strokes.

<p>⚠Caution:</p> <ul style="list-style-type: none">• Do not damage the stainless steel sheet by bending it forcefully during work. Keep in mind that the edges of the stainless steel sheet can cause injuries. Always wear gloves when working on it. The front bracket is supporting the ball screw. Do not detach it. If the front bracket loses its tuned condition, it may cause an increase of driving resistance, shortened life of each component or abnormal noise due to the center of the axis being off the right position.• In case the grease got into your eye, immediately go see the doctor to get appropriate care. After finishing the grease supply work, wash your hands carefully with water and soap to rinse the grease OFF.
--

4.7 Procedure for Stainless Steel Sheet Replacement and Adjustment

In this section, explains how to replace and adjust the stainless steel sheet.

Prepare a storage box and keep there the parts such as screws that have been removed for replacement, for they will be necessary upon re-assembling.

4.7.1 Preparation

(1) Items required for replacing the stainless steel sheet

- Replacement stainless steel sheet
- Phillips screwdriver
- Scale

(2) Caution for the stainless steel sheet tension

Degradation and wear-out of the stainless steel sheet relies on its tension of attachment.

If the stainless steel sheet is pulled with a huge force and the gap between the sheet and the slider cover is large, there is a risk of metal fatigue.

On the other hand, if the tensile strength is too low, the stainless steel sheet would interfere with the back side of the slider cover and make dust to be generated. Therefore, adjust the tensile strength of the stainless sheet by the dedicated adjustment jig so as to the gap between the stainless sheet and the slider cover back will match the predetermined measurement.

(3) Names of the Parts

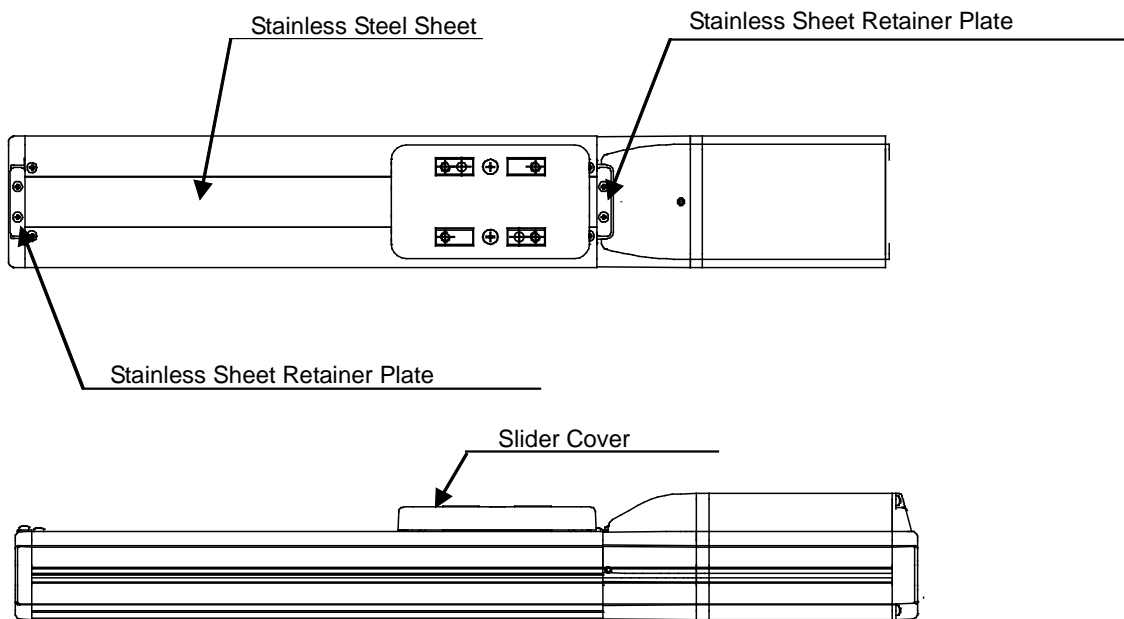

4.7.2 Procedure for Replacement and Tuning

Have a replacement and tuning in (1) Procedure 1 for SA4.

For other models, have a replacement and tuning in either (1) Procedure 1 or (2) Procedure 2.

(1) Procedure 1

- 1) Remove the screws (4 places) holding the stainless steel sheet and stainless steel sheet retainer plates (2 pieces) with using a Phillips screwdriver.
- 2) Pull the old stainless steel sheet till in front of the slider.
Make sure not to pull it out completely off the slider.



In front of Slider

- 3) Join a new stainless steel sheet to the old one with using cellophane tape.

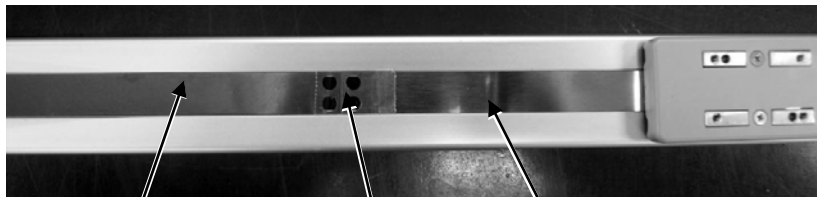

New stainless steel sheet

Join with cellophane tape

Old stainless steel sheet

- 4) Pull the old stainless steel sheet so the new one goes through below the slider. Pull it till the new stainless steel sheet comes to the edge of the actuator.

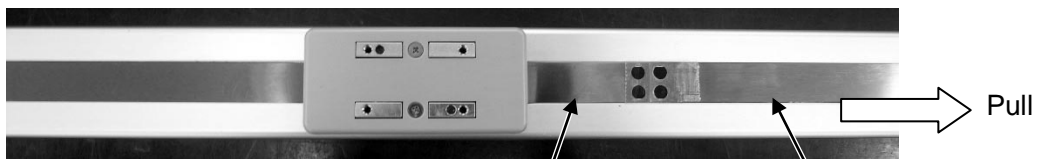

New stainless steel sheet

Old stainless steel sheet



Edge

- 5) Remove the old stainless steel sheet.

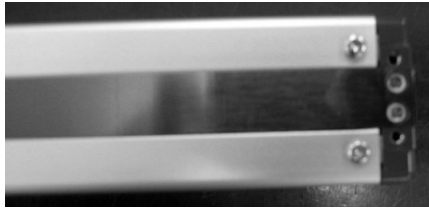

- 6) Fix the two stainless steel sheet retainer plates using the screws (four locations). Use a Phillips screwdriver to attach it.



There are two grooves for stainless steel sheet attachment guides. Align so that the stainless steel sheet is positioned at the center between the two grooves. Attach the stainless steel sheet so that it is not bent.

Tightening Torque
41.4N·cm

- 7) After the stainless steel sheet retainer plates have been fixed, move the slider from one side to the other side (full stroke) with your hand to check that there is no rise or slackness in the stainless steel sheet. If there is any problem, repeat from step 6).

(2) Procedure 2

- 1) Remove the screws (4 places) holding the stainless steel sheet and stainless steel sheet retainer plates (2 pieces) with using a Phillips screwdriver.
- 2) Pull out the old stainless steel sheet.

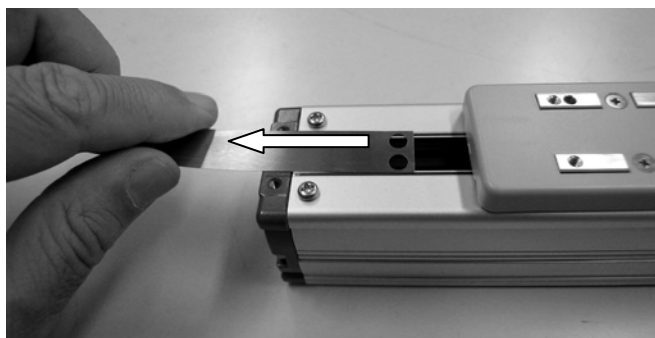

- 3) Attach adhesive tape on one side of new stainless steel sheet.

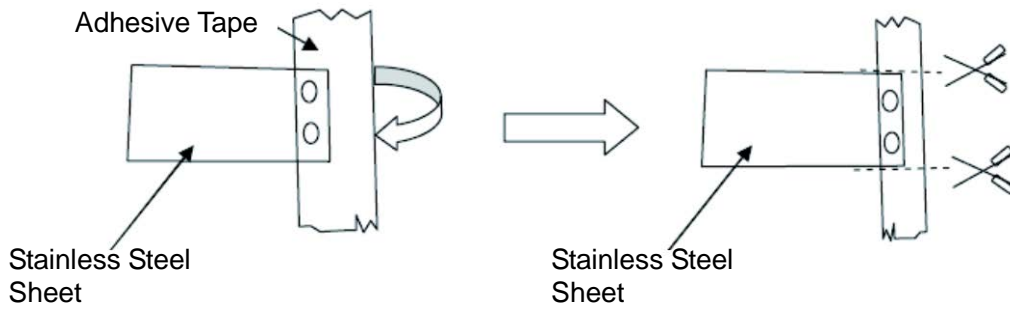

Attach adhesive tape so that it wraps around the end side of the stainless steel sheet. At that time, arrange it so that about 3mm of the end of the tape projects from the stainless steel sheet. Cut any tape excess.

- 4) Put the stainless steel sheet with an adhesive tape on the side cover.

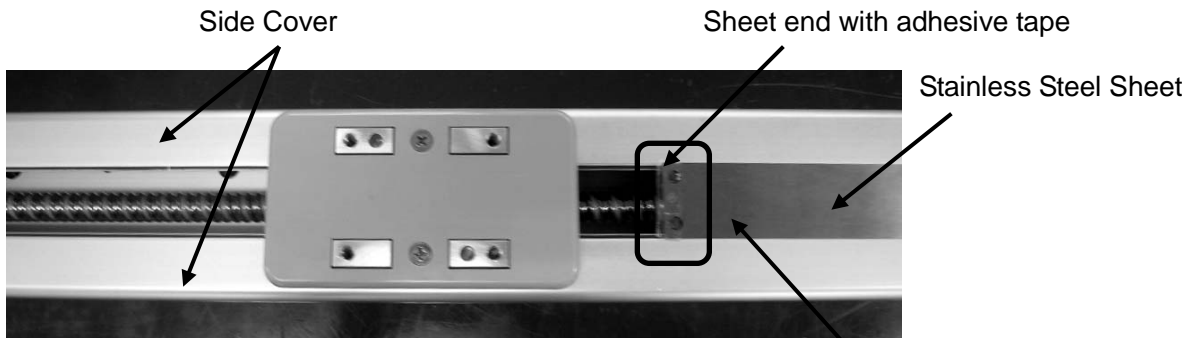

Take care not to drop the stainless steel sheet into the hole.

- 5) With the stainless steel sheet being held, move the slider to put through the stainless steel sheet.

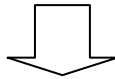
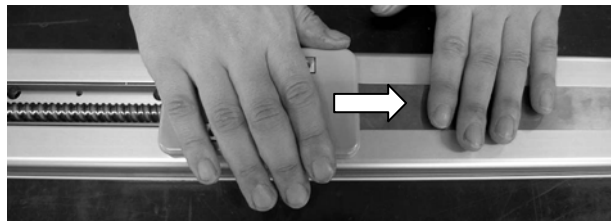
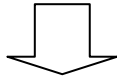
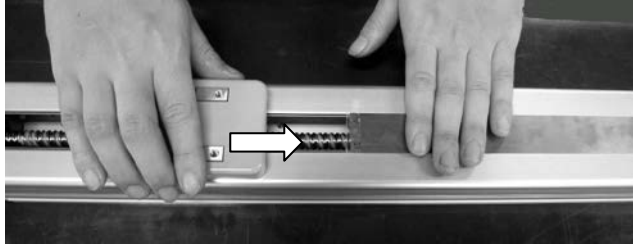

- 6) After the stainless steel sheet passes through the slider, pull one end of the stainless steel sheet out to the position of the stainless steel retainer plate. Take off the adhesive tape once positioning is finished.

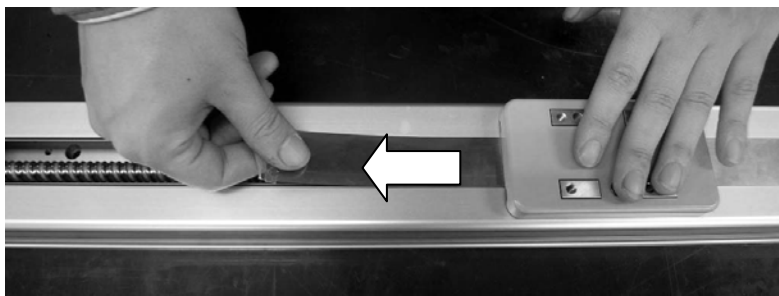

- 7) Fix the two stainless steel sheet retainer plates using the screws (four locations).
Use a Phillips screwdriver to attach it.



There are two grooves for stainless steel sheet attachment guides. Align so that the stainless steel sheet is positioned at the center between the two grooves. Attach the stainless steel sheet so that it is not bent.

Tightening Torque
41.4N·cm

- 8) After the stainless steel sheet retainer plates have been fixed, move the slider from one side to the other side (full stroke) with your hand to check that there is no rise or slackness in the stainless steel sheet. If there is any problem, repeat from step 7).

4.8 Procedure for Belt Replacement and Tuning

Application : RA4R, RA6R, SA7R, SA8R

4.8.1 Inspection of the Belt

For inspection work, detach the pulley cover with hexagonal wrench and carry it out by visual. Remove two hexagonal socket flat-head bolts for SA4R, SA6R, SA7R, and SA8R (where marked with a circle).

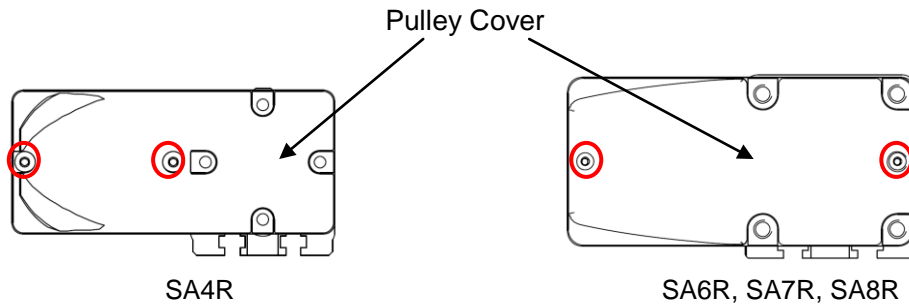

The period of replacement for the belt cannot be clearly defined as the durability of it is impacted so much by the operational conditions.

In generally speaking, it possesses bending life of several million times.

The timing belt gets worn away as the time passes, and it is necessary to have replacement at regular intervals with the following conditions as reference.

- When the gear and belt area show obvious friction.
- When swelling occurs as a result of oil adhesion.
- When damages such as a crack occurs on the belt gear and back side.

Also, for the toothed belt, it is recommended to set the interval of regular replacement cycle when in use under high wire fatigue condition in high acceleration and deceleration because it is difficult to judge the right timing for replacement by checking appearance or looseness of the wires strengthening the belt.

4.8.2 Belt to Use

IAI uses the following belt in our plant

Model	IAI Maintenance Part Code	Manufacturer Model Code	
SA4R	TB-RCP6-STRA4R	60S2M148 GB	Rubber, Super torque G Bareback specification (Mitsuboshi Belting Ltd.)
SA6R	TB-RCP6-STRA6R	60S2M182 GB	Rubber, Super torque G Bareback specification (Mitsuboshi Belting Ltd.)
SA7R	TB-RCP6-STRA7R	100S3M225 GB	Rubber, Super torque G Bareback specification (Mitsuboshi Belting Ltd.)
SA8R	TB-RCP6-SA8R	100S3M243 GB	Rubber, Super torque G Bareback specification (Mitsuboshi Belting Ltd.)

4.8.3 Belt Replacement

[Items required for replacing the motor]

- Belt for Replacement
- Hexagon Wrench 2.5mm(SA4R), 3mm(SA6R/SA7R/SA8R)
2mm (for hexagonal socket flat-head cap screw)
- Phillips screwdriver
- Tension Gauge (that is available for pulling with 90N)
- Long Tie-Band (thin string)

[Procedure]

- 1) Remove two hexagonal socket flat-head bolts for SA4R, SA6R, SA7R, and SA8R (where marked with a circle) with a hexagonal wrench. Detach the pulley cover.

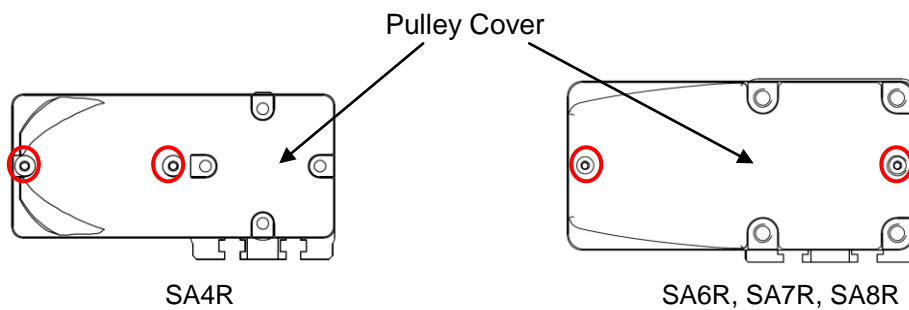

- 2) Remove the four Phillips screws by Phillips screwdriver and remove the motor cover.

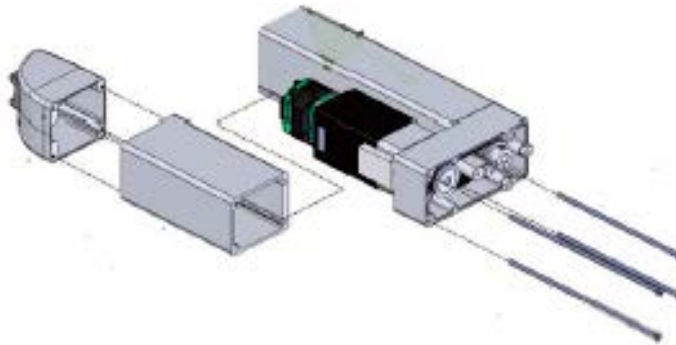

- 3) After tension adjustment of the belt, remove the following bolts and circular washers that are attached for position repeatability of the motor with 2.5mm-sized hexagonal wrench.

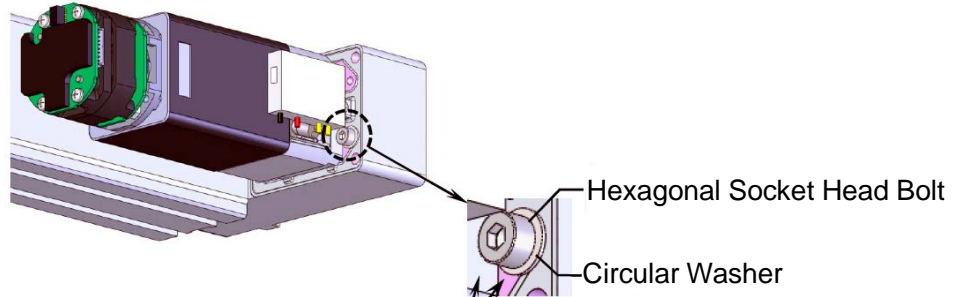

The washer is attached in close contact with the motor bracket.

- 4) Loosen the bolts (where marked with a circle; two bolts for SA4R, four bolts for SA6R, SA7R, and SA8R) holding the motor with a 2.5mm-sized (SA4R) or 3mm-sized (SA6R/SA7R/SA8R) hexagonal wrench. Replace the belt if it is necessary.

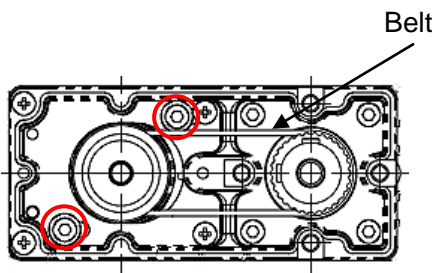

SA4R

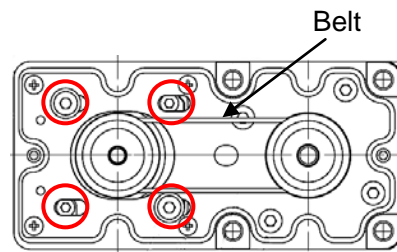

SA6R, SA7R, SA8R4

- 5) Adjust the belt tension.
 Hand a cable band (thin string) on the edge of the motor unit and pull it on a tension gauge with the specified load (specified value of the belt tension).
 When the load reached the specified, tighten the bolts (where marked with a circle) with a 2.5mm-sized (SA4R) or 3mm-sized (SA6R/SA7R/SA8R) hexagonal wrench to hold the unit in the place.

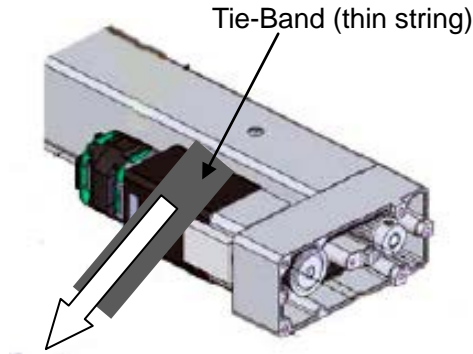

Model	Tension Force
SA4R	20 to 25N
SA6R	25 to 30N
SA7R	80 to 90N
SA8R	80 to 90N

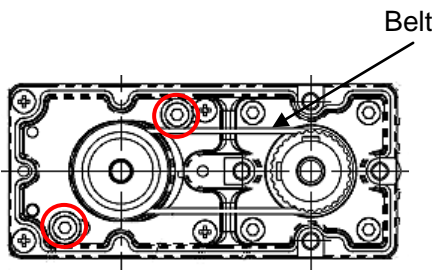

SA4R

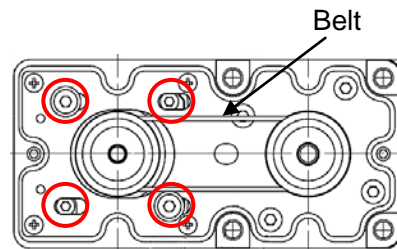

SA6R, SA7R, SA8R

Model	Tightening Torque
SA4R	162N cm
SA6R	323N cm
SA7R	323N cm
SA8R	323N cm

- 6) After tension adjustment of the belt, tighten the following bolts and circular washers attached for position repeatability of the motor in close contact with the motor bracket with 2.5mm-sized hexagonal wrench.

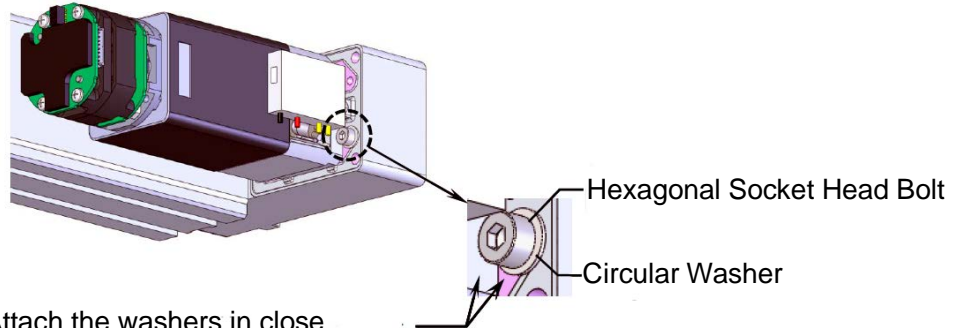

Attach the washers in close contact with the motor bracket.

Tightening Torque
88.7N·cm

- 7) Attach the motor cover with four Phillips screws and tighten them with Phillips screwdriver.

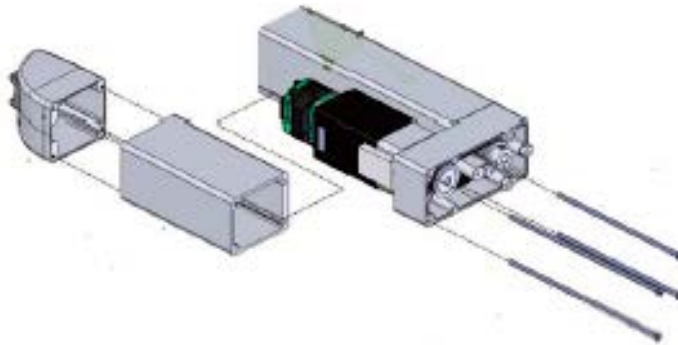

Model	Tightening Torque
SA4R, SA6R, SA7R, SA8R	41.4N·cm

- 8) Attach the pulley cover with two hexagonal socket flat-head bolts for SA4R, SA6R, SA7R, and SA8R (where marked with a circle) and tighten with a hexagonal wrench.

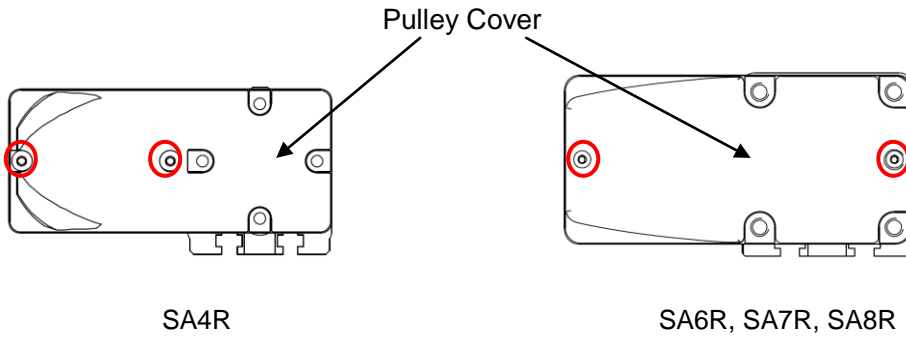

SA4R

SA6R, SA7R, SA8R

Tightening Torque
47.9N·cm

4.9 Motor Replacement Process



Caution: The encoder part of the motor for replacement and the control board of RCP6S may fail due to static electricity. Please be sure to follow the following precautions during work.

- Do not touch the encoder part of the motor for replacement directly with hands.
- Do not touch the control board directly with hands except when replacing the control board of RCP6S.
- Before replacement work, touch metal objects and the like to release any static electricity from body.
- Do not perform replacement work at the place where static electricity is likely to occur (carpet, etc).

4.9.1 SA4C, SA6C, SA7C, SA8C

[Items required for replacing the motor]

- Motor Unit for Replacement

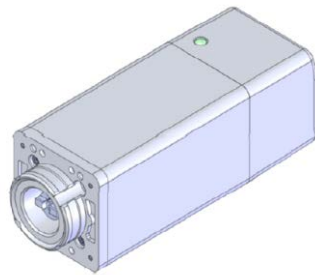

For RCP6

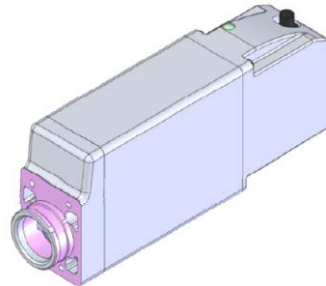

For RCP6S

- Hexagonal wrench set 2mm or 2.5mm-sized

[Procedure]

- 1) Remove the fixing screw affixing the actuator and the motor unit with a 2mm-sized (SA4C, SA6C) or 2.5mm-sized (SA7C, SA8C) hexagonal wrench.
- 2) Detach the motor unit.

For fixed screws actuator and motor unit

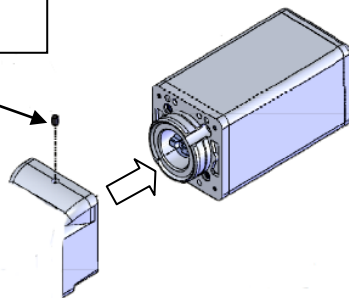

- 3) Make the profiles on the actuator side and motor unit side aligned so the projection matches to the slit.

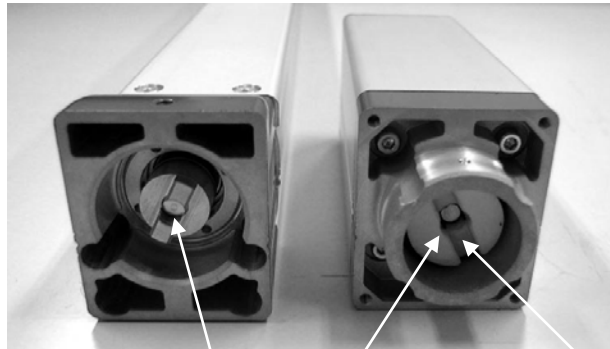

Make the projection and slit matched with each other.

Apply grease to the coupling part. NOXLUB TL1010 grease made by NOK

- 4) Attach the motor unit for replacement with the projection being matched with the slit.
- 5) Tighten the fixing screw to affixing the motor unit to the actuator with 2mm-sized (SA4C, SA6C) or 2.5mm-sized (SA7C, SA8C) hexagonal wrench.

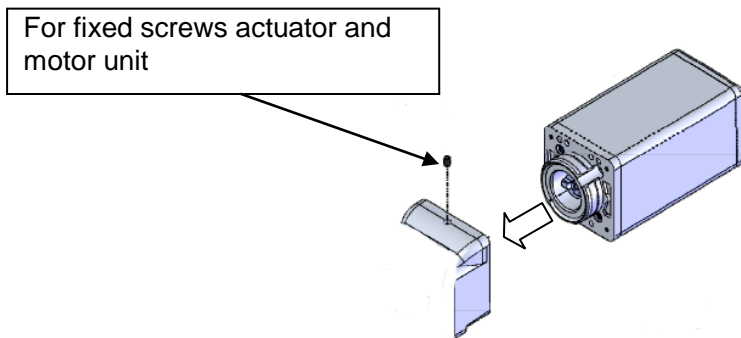

Model	Tightening Torque
SA4C, SA6C	167N·cm
SA7C, SA8C	353N·cm

- 6) Make sure to conduct a home return on a PC or a touch panel teaching after motor replacement.

4.9.2 SA4R, SA6R, SA7R, SA8R

[Items required for replacing the motor]

- Motor unit for replacement

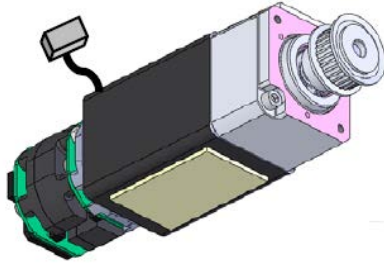

- Hexagon wrench set 2.5mm(SA4R), 3mm(SA6R/SA7R/SA8R)
2mm (for hexagonal socket bolt)
- Phillips screwdriver
- Tension gauge (capable thing of tensioning to 90N or greater)
- Strong string or long tie-band

[Procedure]

- 1) Remove two hexagonal socket flat-head bolts for SA4R, SA6R, SA7R, and SA8R (where marked with a circle) with a hexagonal wrench. Detach the pulley cover.

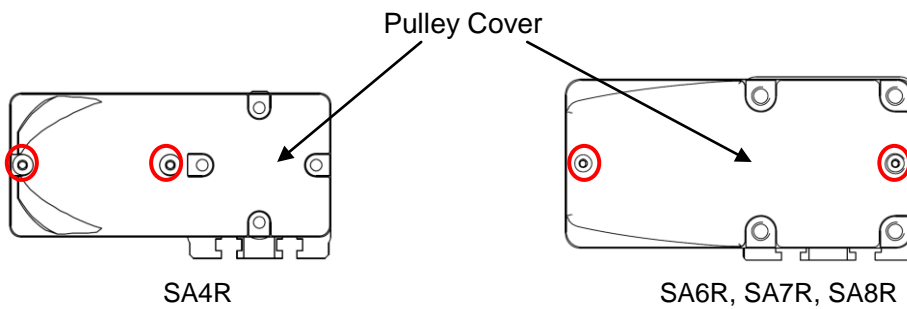

- 2) Remove the four Phillips screws by Phillips screwdriver and remove the motor cover.

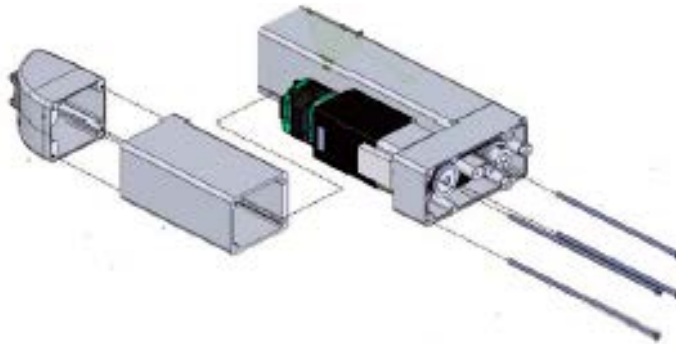

- 3) If the belt is to be replaced at the same time, remove the following bolts and circular washers that are mounted for position repeatability of the motor by 2.5mm-sized hexagonal wrench, after tension adjustment of the belt,

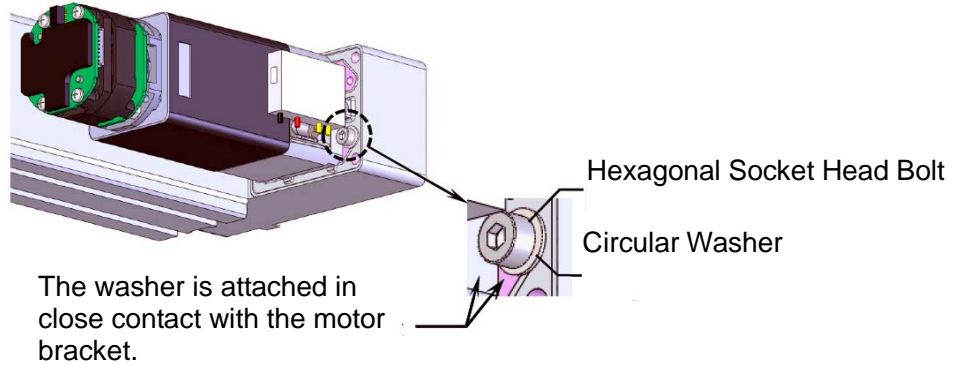

- 4) Loosen the bolts (where marked with a circle; two bolts for SA4R, four bolts for SA6R, SA7R, and SA8R) holding the motor with a 2.5mm-sized (SA4R) or 3mm-sized (SA6R/SA7R/SA8R) hexagonal wrench. Replace the belt if it is necessary.

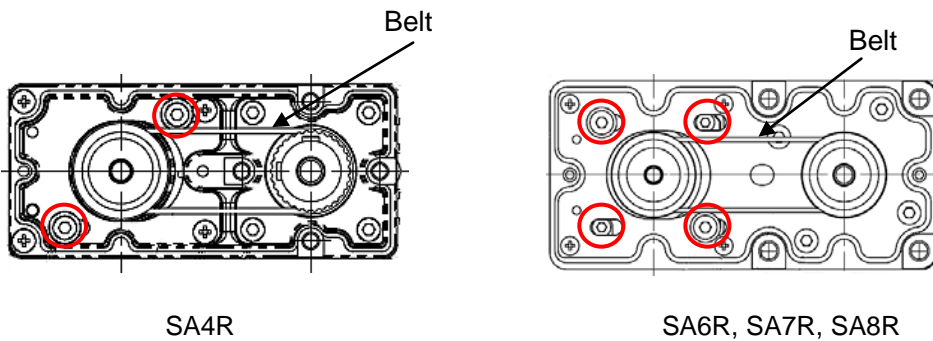

- 5) Detach the belt off the pulleys.
- 6) Pull out four bolts and remove the motor unit.

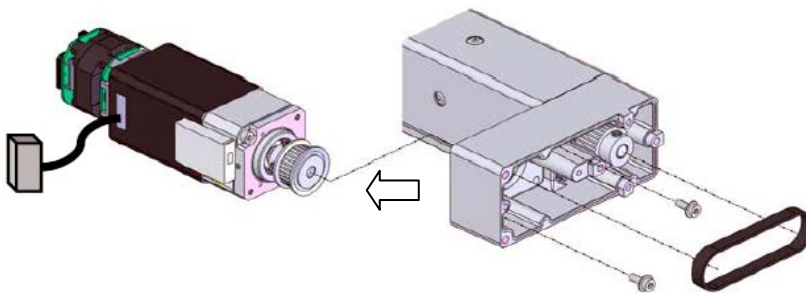

- 7) Install the new motor and temporarily tighten the tension adjustment bolts (encircled parts). Hang the timing belt.

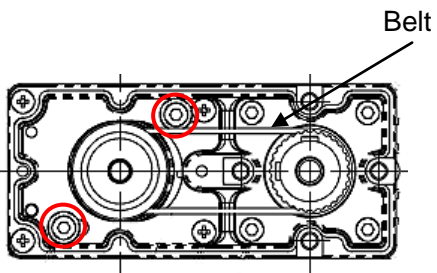
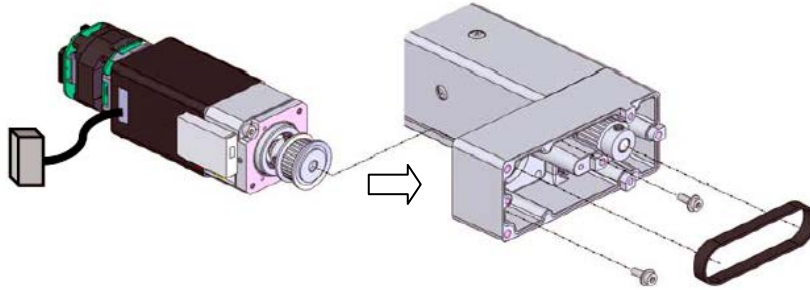

SA4R

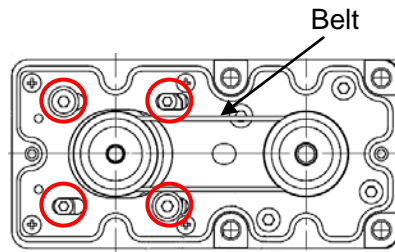

SA6R, SA7R, SA8R

(Note) If the belt is not replaced at the same time and the following hexagonal socket bolts and circular washers are not removed, there is no need to adjust tension of the belt as prescribed in 8).

Hand a cable band (thin string) on the edge of the motor unit and pull it. When it is abutting against the hexagonal socket bolt, tighten the bolt (where marked with a circle) with 2.5mm-sized (SA4R) or 3mm-sized (SA6R/SA7R/SA8R) hexagonal wrench to hold the unit in the place.

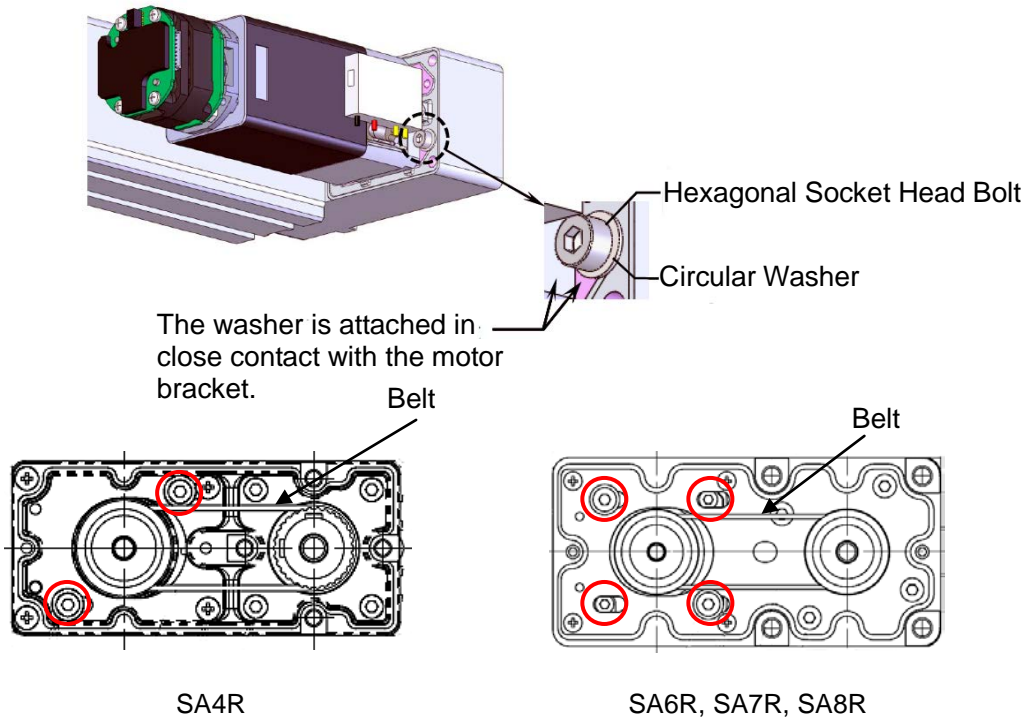

Model	Tightening Torque
SA4R	162N·cm
SA6R	323N·cm
SA7R	323N·cm
SA8R	323N·cm

- 8) If the belt has been replaced at the same time, adjust the tension of the belt.
 Hand a cable band (thin string) on the edge of the motor unit and pull it on a tension gauge with the specified load (specified value of the belt tension).
 When the load reached the specified, tighten the bolts (where marked with a circle) with a 2.5mm-sized (SA4R) or 3mm-sized (SA6R/SA7R/SA8R) hexagonal wrench to hold the unit in the place.

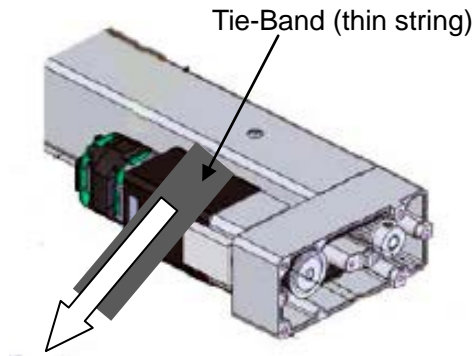

Model	Tension Force
SA4R	20 to 25N
SA6R	25 to 30N
SA7R	80 to 90N
SA8R	80 to 90N

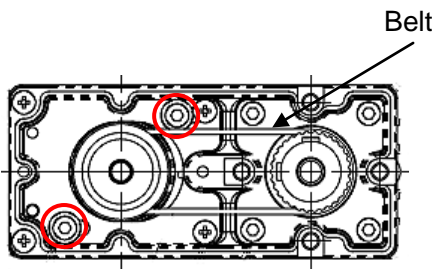

SA4R

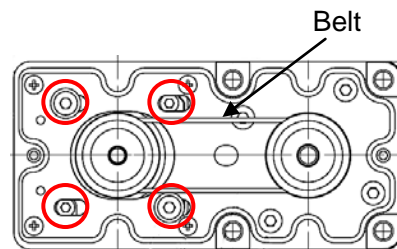

SA6R, SA7R, SA8R

Model	Tightening Torque
SA4R	162N·cm
SA6R	323N·cm
SA7R	323N·cm
SA8R	323N·cm

- 9) If the belt has been replaced at the same time, tighten the following bolts and circular washers that are mounted for position repeatability of the motor with 2.5-mm sized hexagonal wrench after tension adjustment of the belt.

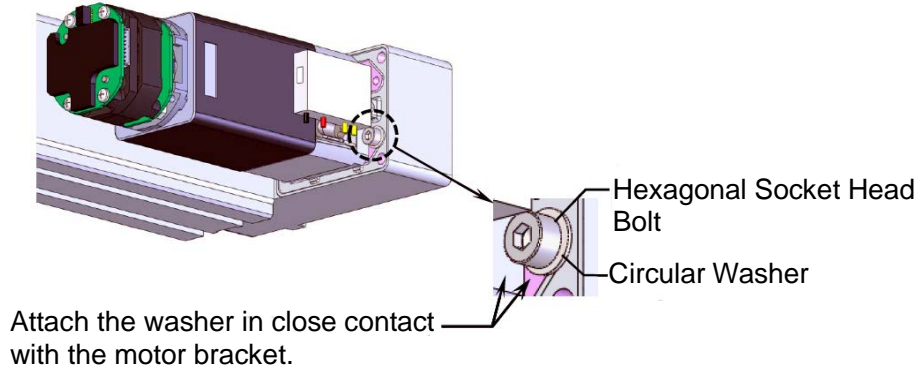

Tightening Torque
88.7N·cm

- 10) Attach the motor cover with four Phillips screws and tighten them with Phillips screwdriver.

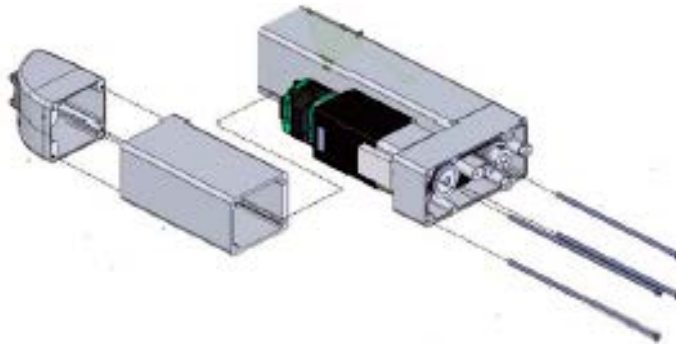

Model	Tightening Torque
SA4R, SA6R, SA7R, SA8R	41.4N·cm

- 11) Attach the pulley cover with two hexagonal socket flat-head bolts for SA4R, SA6R, SA7R, and SA8R (where marked with a circle) and tighten with a hexagonal wrench.

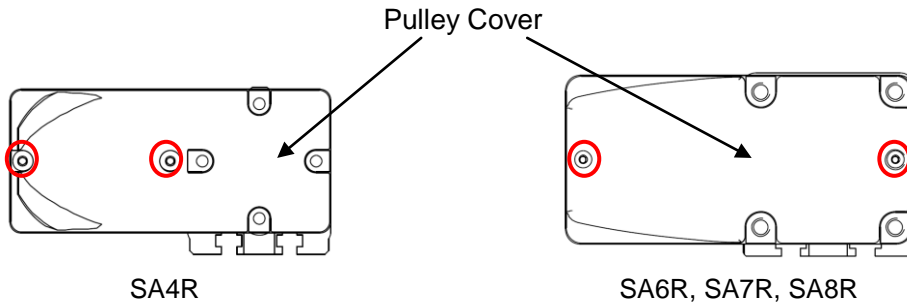

Tightening Torque
47.9N·cm

- 12) Make sure to conduct a home return on a PC or a touch panel teaching after motor replacement.

5. External Dimensions

5.1 Standard Specification RCP6-SA4C

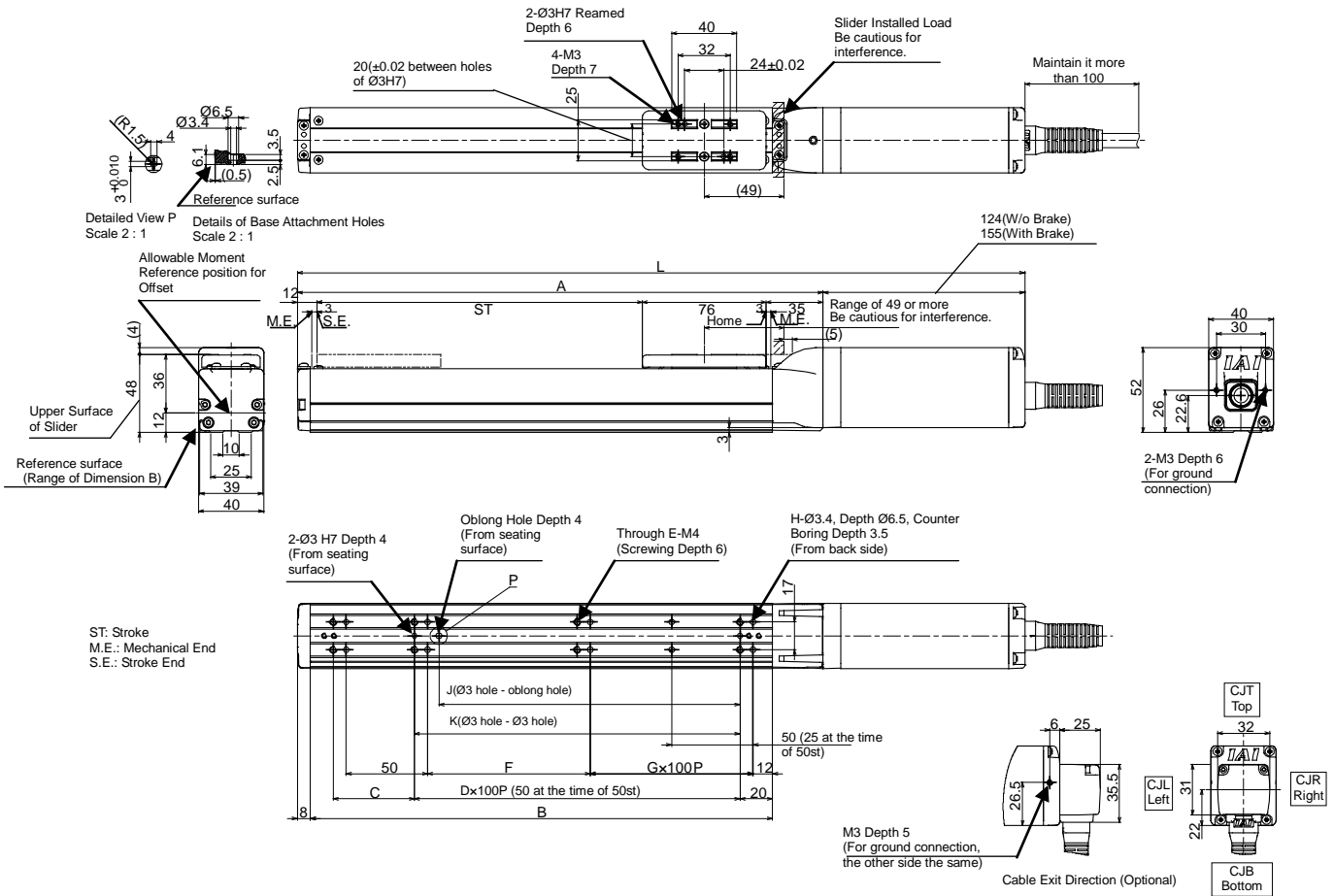

Stroke	L		A	B	C	D	E	F	G	H	J	K	Mass [kg]	
	W/o Brake	With Brake											W/o Brake	With Brake
50	297	328	173	134	50	0	6	50	0	8	35	50	1.1	1.3
100	347	378	223	184	50	1	6	100	0	8	85	100	1.2	1.4
150	397	428	273	234	100	1	6	50	1	10	85	100	1.3	1.5
200	447	478	323	284	50	2	8	100	1	10	185	200	1.4	1.5
250	497	528	373	334	100	2	8	50	2	12	185	200	1.5	1.6
300	547	578	423	384	50	3	10	100	2	12	285	300	1.6	1.7
350	597	628	473	434	100	3	10	50	3	14	285	300	1.7	1.8
400	647	678	523	484	50	4	12	100	3	14	385	400	1.7	1.9
450	697	728	573	534	100	4	12	50	4	16	385	400	1.8	2.0
500	747	778	623	584	50	5	14	100	4	16	485	500	1.9	2.1

(Note) L dimensions described in the table are those with no cable exit direction (option). For cable exit direction types (option), the dimensions are longer in 25mm.

5.2 Built-in Controller Specification RCP6S-SA4C

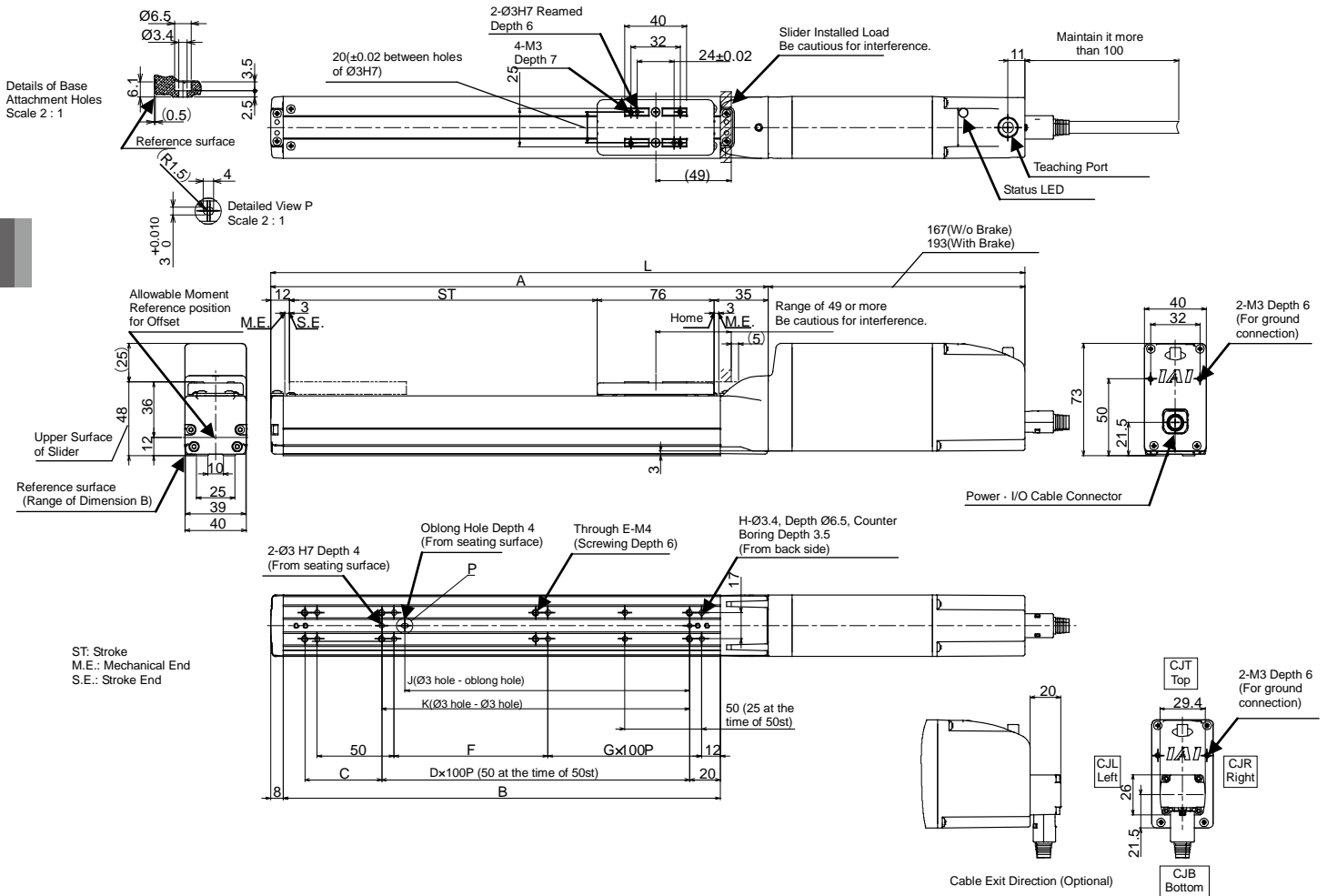

Stroke	L		A	B	C	D	E	F	G	H	J	K	Mass [kg]	
	W/o Brake	With Brake											W/o Brake	With Brake
50	340	366	173	134	50	0	6	50	0	8	35	50	1.3	1.5
100	390	416	223	184	50	1	6	100	0	8	85	100	1.4	1.6
150	440	466	273	234	100	1	6	50	1	10	85	100	1.5	1.6
200	490	516	323	284	50	2	8	100	1	10	185	200	1.6	1.7
250	540	566	373	334	100	2	8	50	2	12	185	200	1.7	1.8
300	590	616	423	384	50	3	10	100	2	12	285	300	1.8	1.9
350	640	666	473	434	100	3	10	50	3	14	285	300	1.8	2.0
400	690	716	523	484	50	4	12	100	3	14	385	400	1.9	2.1
450	740	766	573	534	100	4	12	50	4	16	385	400	2.0	2.2
500	790	816	623	584	50	5	14	100	4	16	485	500	2.1	2.3

(Note) L dimensions described in the table are those with no cable exit direction (option). For cable exit direction types (option), the dimensions are longer in 20mm.

5.3 Standard Specification RCP6-SA6C

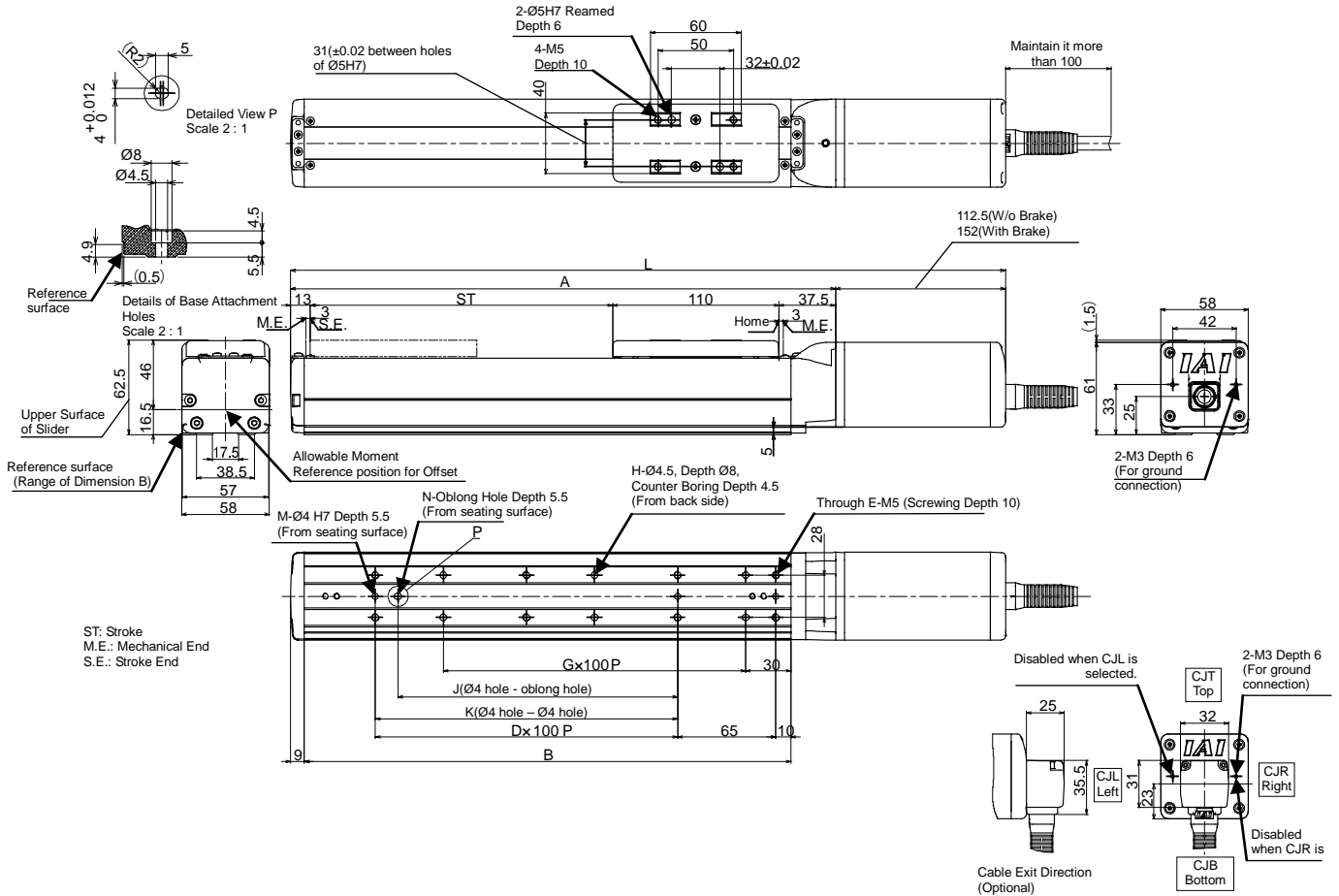

Stroke	L		A	B	D	E	G	H	J	K	M	N	Mass [kg]	
	W/o Brake	With Brake											W/o Brake	With Brake
50	323	362.5	210.5	172	0	4	1	4	0	0	2	0	2.0	2.2
100	373	412.5	260.5	222	1	6	1	4	85	100	3	1	2.2	2.4
150	423	462.5	310.5	272	1	6	2	6	85	100	3	1	2.3	2.6
200	473	512.5	360.5	322	2	8	2	6	185	200	3	1	2.5	2.8
250	523	562.5	410.5	372	2	8	3	8	185	200	3	1	2.7	2.9
300	573	612.5	460.5	422	3	10	3	8	285	300	3	1	2.8	3.1
350	623	662.5	510.5	472	3	10	4	10	285	300	3	1	3.0	3.3
400	673	712.5	560.5	522	4	12	4	10	385	400	3	1	3.2	3.4
450	723	762.5	610.5	572	4	12	5	12	385	400	3	1	3.4	3.6
500	773	812.5	660.5	622	5	14	5	12	485	500	3	1	3.5	3.8
550	823	862.5	710.5	672	5	14	6	14	485	500	3	1	3.7	4.0
600	873	912.5	760.5	722	6	16	6	14	585	600	3	1	3.9	4.1
650	923	962.5	810.5	772	6	16	7	16	585	600	3	1	4.1	4.3
700	973	1012.5	860.5	822	7	18	7	16	685	700	3	1	4.2	4.5
750	1023	1062.5	910.5	872	7	18	8	18	685	700	3	1	4.4	4.6
800	1073	1112.5	960.5	922	8	20	8	18	785	800	3	1	4.6	4.8

(Note) L dimensions described in the table are those with no cable exit direction (option). For cable exit direction types (option), the dimensions are longer in 25mm.

5.4 Built-in Controller Specification RCP6S-SA6C

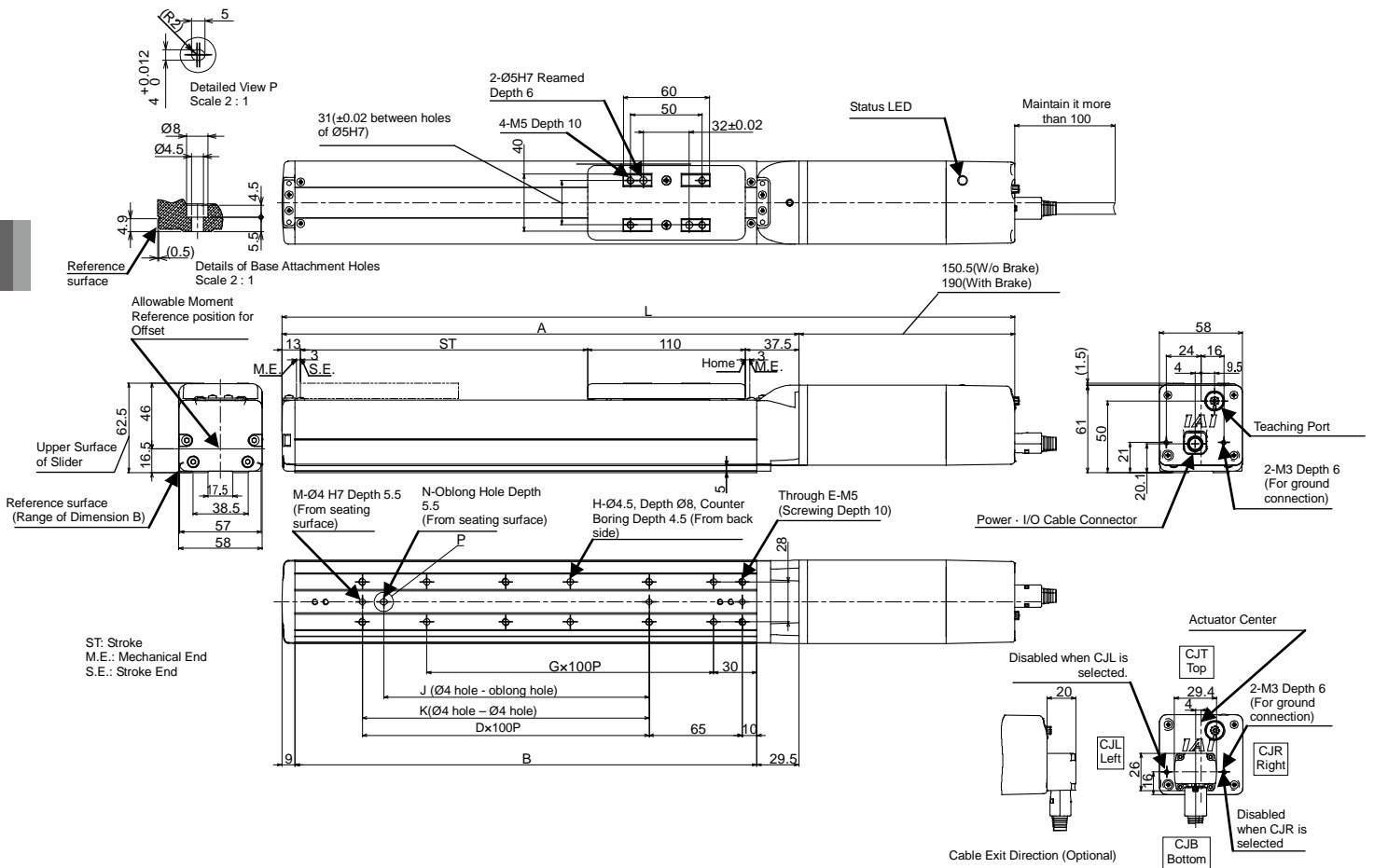

Stroke	L		A	B	D	E	G	H	J	K	M	N	Mass [kg]	
	W/o Brake	With Brake											W/o Brake	With Brake
50	361	400.5	210.5	172	0	4	1	4	0	0	2	0	2.1	2.4
100	411	450.5	260.5	222	1	6	1	4	85	100	3	1	2.3	2.5
150	461	500.5	310.5	272	1	6	2	6	85	100	3	1	2.5	2.7
200	511	550.5	360.5	322	2	8	2	6	185	200	3	1	2.6	2.9
250	561	600.5	410.5	372	2	8	3	8	185	200	3	1	2.8	3.1
300	611	650.5	460.5	422	3	10	3	8	285	300	3	1	3.0	3.2
350	661	700.5	510.5	472	3	10	4	10	285	300	3	1	3.2	3.4
400	711	750.5	560.5	522	4	12	4	10	385	400	3	1	3.3	3.6
450	761	800.5	610.5	572	4	12	5	12	385	400	3	1	3.5	3.8
500	811	850.5	660.5	622	5	14	5	12	485	500	3	1	3.7	3.9
550	861	900.5	710.5	672	5	14	6	14	485	500	3	1	3.9	4.1
600	911	950.5	760.5	722	6	16	6	14	585	600	3	1	4.0	4.3
650	961	1000.5	810.5	772	6	16	7	16	585	600	3	1	4.2	4.4
700	1011	1050.5	860.5	822	7	18	7	16	685	700	3	1	4.4	4.6
750	1061	1100.5	910.5	872	7	18	8	18	685	700	3	1	4.6	4.8
800	1111	1150.5	960.5	922	8	20	8	18	785	800	3	1	4.7	4.9

(Note) L dimensions described in the table are those with no cable exit direction (option). For cable exit direction types (option), the dimensions are longer in 20mm.

5.5 Standard Specification RCP6-SA7C

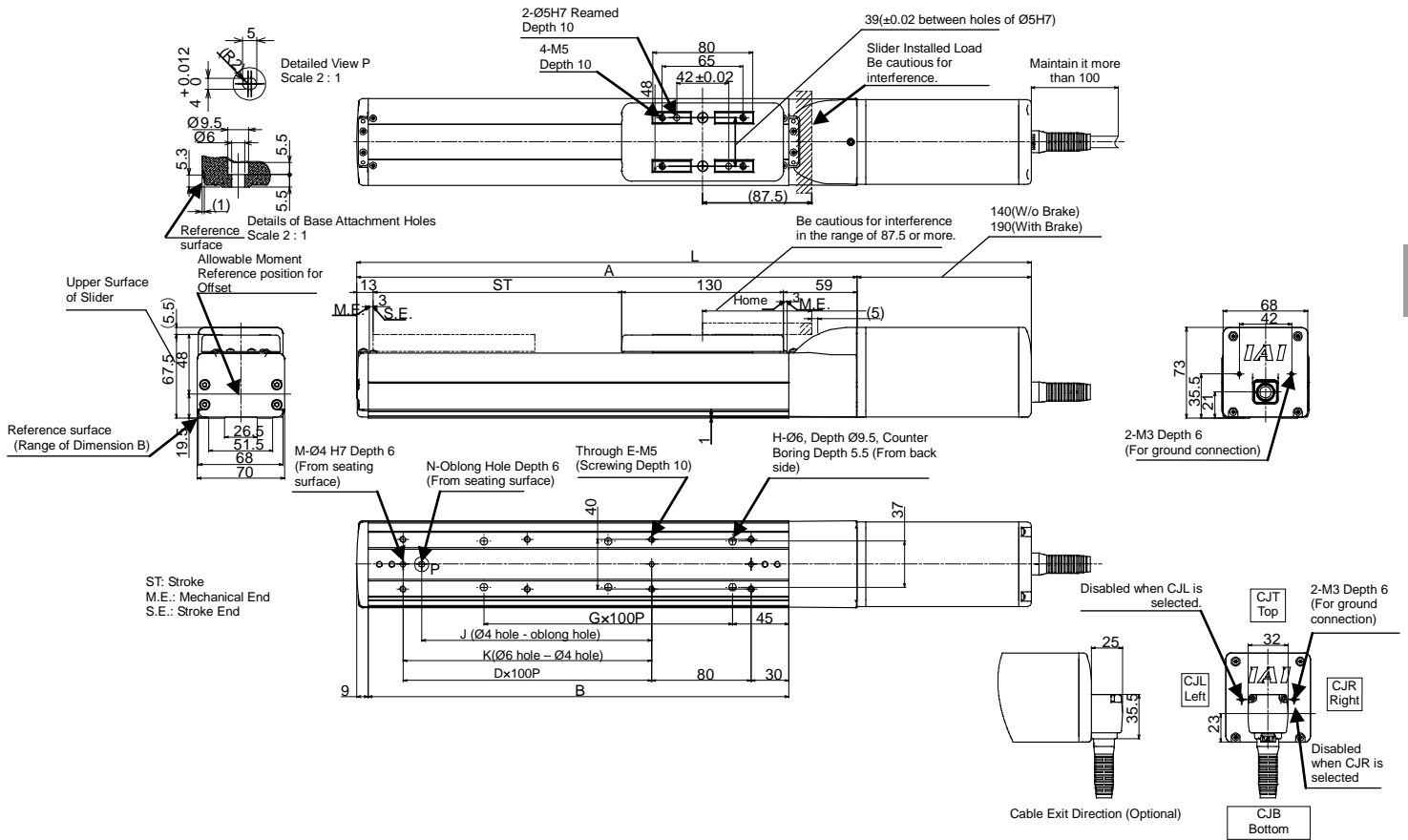

Stroke	L		A	B	D	E	G	H	J	K	M	N	Mass [kg]	
	W/o Brake	With Brake											W/o Brake	With Brake
50	392	442	252	188	0	4	1	4	0	0	2	0	3.6	4.0
100	442	492	302	238	1	6	1	4	85	0	2	1	3.8	4.2
150	492	542	352	288	1	6	2	6	85	100	3	1	4.0	4.5
200	542	592	402	338	2	8	2	6	185	200	3	1	4.3	4.7
250	592	642	452	388	2	8	3	8	185	200	3	1	4.5	4.9
300	642	692	502	438	3	10	3	8	285	300	3	1	4.7	5.1
350	692	742	552	488	3	10	4	10	285	300	3	1	4.9	5.4
400	742	792	602	538	4	12	4	10	385	400	3	1	5.2	5.6
450	792	842	652	588	4	12	5	12	385	400	3	1	5.4	5.8
500	842	892	702	638	5	14	5	12	485	500	3	1	5.6	6.1
550	892	942	752	688	5	14	6	14	485	500	3	1	5.9	6.3
600	942	992	802	738	6	16	6	14	585	600	3	1	6.1	6.5
650	992	1042	852	788	6	16	7	16	585	600	3	1	6.3	6.7
700	1042	1092	902	838	7	18	7	16	685	700	3	1	6.5	7.0
750	1092	1142	952	888	7	18	8	18	685	700	3	1	6.8	7.2
800	1142	1192	1002	938	8	20	8	18	785	800	3	1	7.0	7.4

(Note) L dimensions described in the table are those with no cable exit direction (option). For cable exit direction types (option), the dimensions are longer in 25mm.

5.6 Built-in Controller Specification RCP6S-SA7C

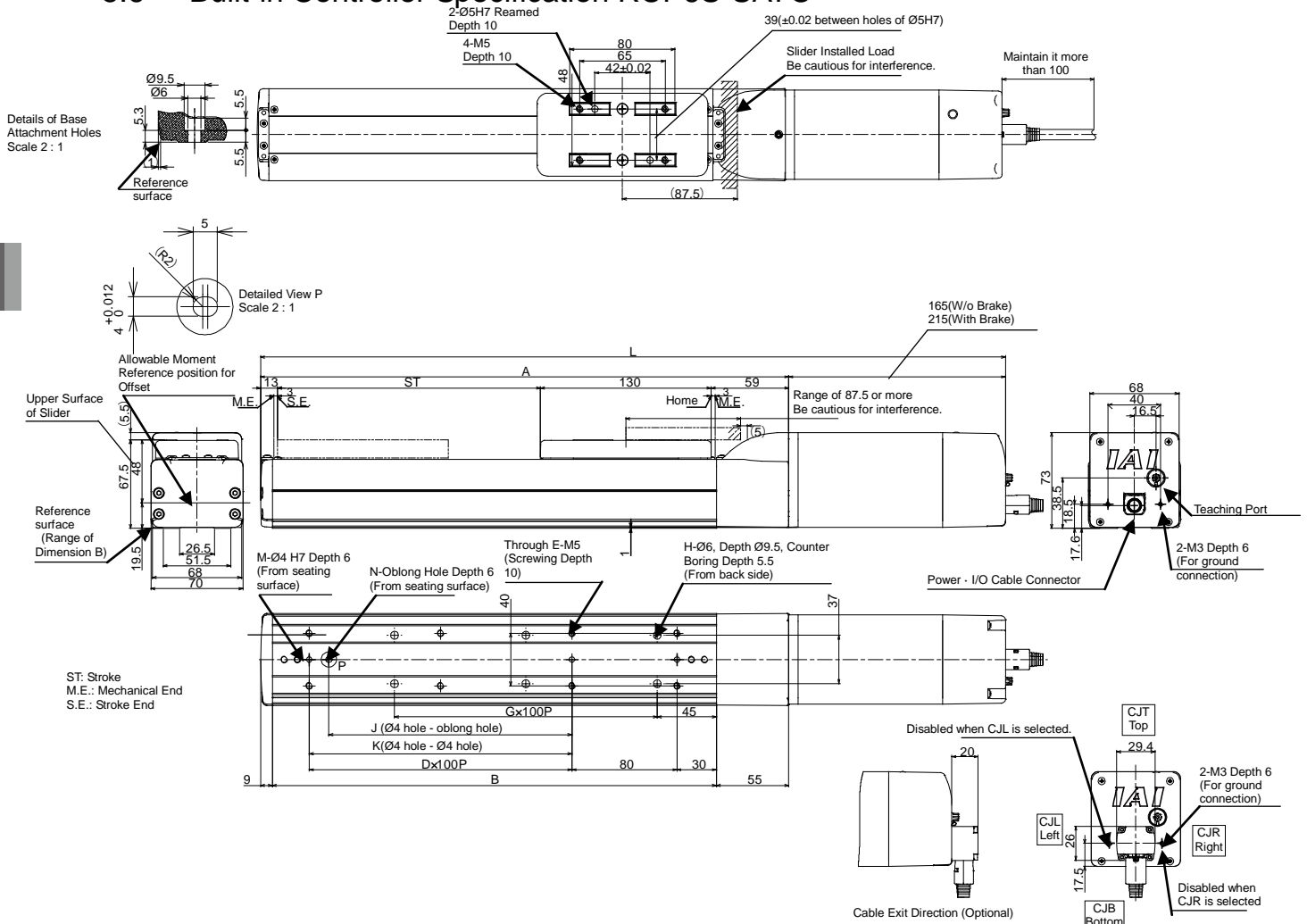

Stroke	L		A	B	D	E	G	H	J	K	M	N	Mass [kg]	
	W/o Brake	With Brake											W/o Brake	With Brake
50	417	467	252	188	0	4	1	4	0	0	2	0	3.8	4.2
100	467	517	302	238	1	6	1	4	85	0	2	1	4.0	4.4
150	517	567	352	288	1	6	2	6	85	100	3	1	4.2	4.6
200	567	617	402	338	2	8	2	6	185	200	3	1	4.4	4.9
250	617	667	452	388	2	8	3	8	185	200	3	1	4.7	5.1
300	667	717	502	438	3	10	3	8	285	300	3	1	4.9	5.3
350	717	767	552	488	3	10	4	10	285	300	3	1	5.1	5.6
400	767	817	602	538	4	12	4	10	385	400	3	1	5.3	5.8
450	817	867	652	588	4	12	5	12	385	400	3	1	5.6	6.0
500	867	917	702	638	5	14	5	12	485	500	3	1	5.8	6.2
550	917	967	752	688	5	14	6	14	485	500	3	1	6.0	6.5
600	967	1017	802	738	6	16	6	14	585	600	3	1	6.3	6.7
650	1017	1067	852	788	6	16	7	16	585	600	3	1	6.5	6.9
700	1067	1117	902	838	7	18	7	16	685	700	3	1	6.7	7.1
750	1117	1167	952	888	7	18	8	18	685	700	3	1	6.9	7.4
800	1167	1217	1002	938	8	20	8	18	785	800	3	1	7.2	7.6

(Note) L dimensions described in the table are those with no cable exit direction (option). For cable exit direction types (option), the dimensions are longer in 20mm.

5.9 Standard Specification RCP6-SA4R Left Side-Mounted (Model: ML)

(Note) For Right Side-Mounted (model: MR), side-mounted motor will be on the right side in the drawing beneath.

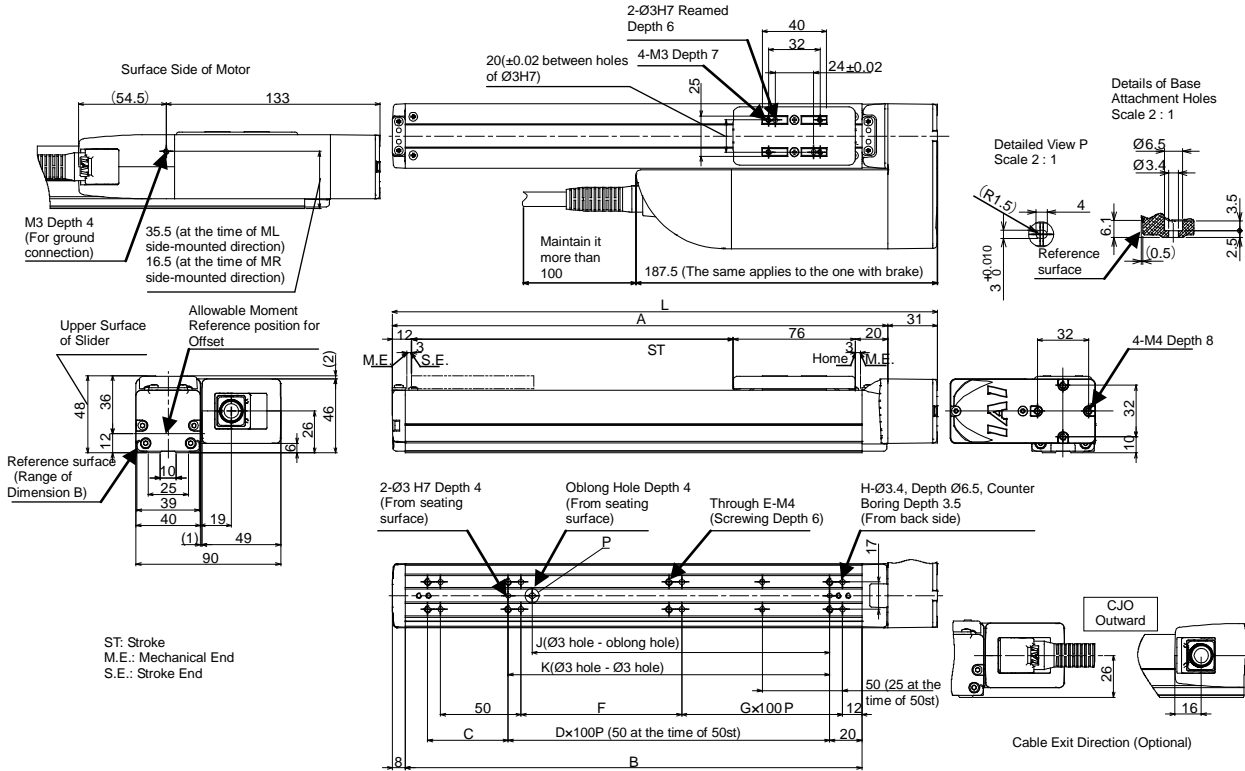

Stroke	L	A	B	C	D	E	F	G	H	J	K	Mass [kg]	
												W/o Brake	With Brake
50	189	158	134	50	0	6	50	0	8	35	50	1.3	1.4
100	239	208	184	50	1	6	100	0	8	85	100	1.4	1.5
150	289	258	234	100	1	6	50	1	10	85	100	1.5	1.5
200	339	308	284	50	2	8	100	1	10	185	200	1.6	1.6
250	389	358	334	100	2	8	50	2	12	185	200	1.7	1.7
300	439	408	384	50	3	10	100	2	12	285	300	1.7	1.8
350	489	458	434	100	3	10	50	3	14	285	300	1.8	1.9
400	539	508	484	50	4	12	100	3	14	385	400	1.9	2.0
450	589	558	534	100	4	12	50	4	16	385	400	2.0	2.1
500	639	608	584	50	5	14	100	4	16	485	500	2.1	2.2

5.10 Built-in Controller Specification RCP6S-SA4R Left Side-Mounted (Model: ML)

(Note) For Right Side-Mounted (model: MR), side-mounted motor will be on the right side in the drawing beneath.

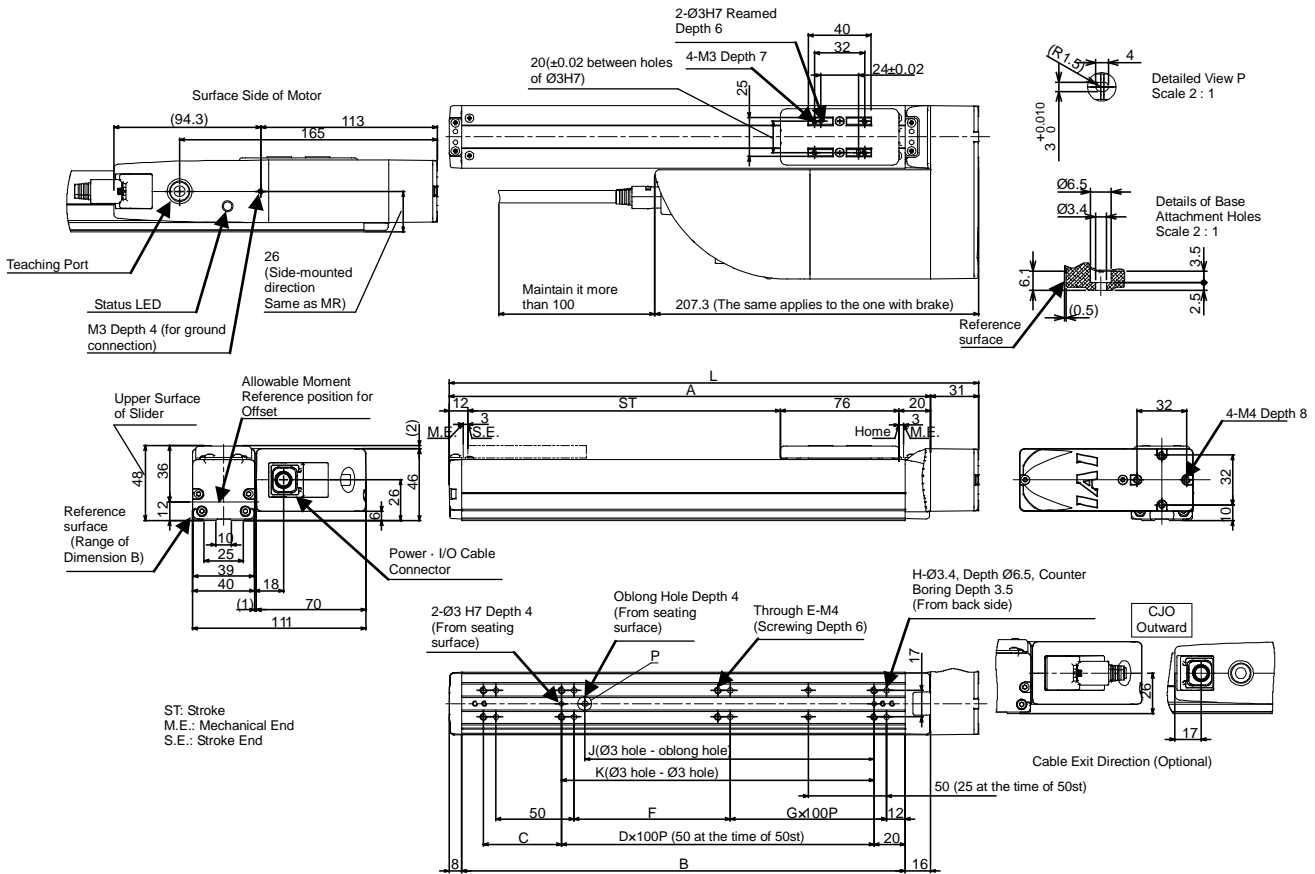

Stroke	L	A	B	C	D	E	F	G	H	J	K	Mass [kg]	
												W/o Brake	With Brake
50	189	158	134	50	0	6	50	0	8	35	50	1.4	1.5
100	239	208	184	50	1	6	100	0	8	85	100	1.5	1.6
150	289	258	234	100	1	6	50	1	10	85	100	1.6	1.7
200	339	308	284	50	2	8	100	1	10	185	200	1.7	1.8
250	389	358	334	100	2	8	50	2	12	185	200	1.8	1.8
300	439	408	384	50	3	10	100	2	12	285	300	1.9	1.9
350	489	458	434	100	3	10	50	3	14	285	300	2.0	2.0
400	539	508	484	50	4	12	100	3	14	385	400	2.0	2.1
450	589	558	534	100	4	12	50	4	16	385	400	2.1	2.2
500	639	608	584	50	5	14	100	4	16	485	500	2.2	2.3

5.11 Standard Specification RCP6-SA6R Left Side-Mounted (Model: ML)

(Note) For Right Side-Mounted (model: MR), side-mounted motor will be on the right side in the drawing beneath.

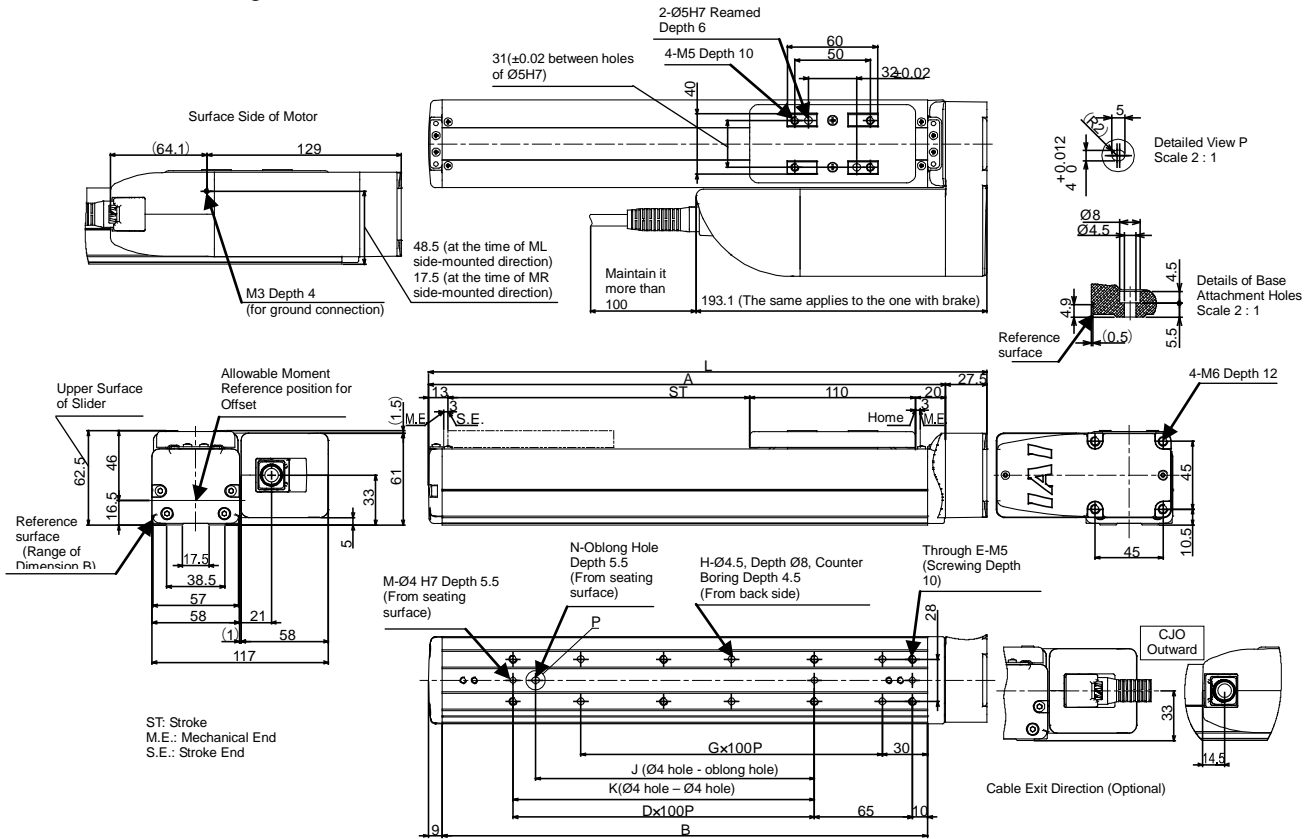

Stroke	L	A	B	D	E	G	H	J	K	M	N	Mass [kg]	
												W/o Brake	With Brake
50	220.5	193	172	0	4	1	4	0	0	2	0	2.3	2.4
100	270.5	243	222	1	6	1	4	85	100	3	1	2.5	2.5
150	320.5	293	272	1	6	2	6	85	100	3	1	2.6	2.7
200	370.5	343	322	2	8	2	6	185	200	3	1	2.8	2.9
250	420.5	393	372	2	8	3	8	185	200	3	1	3.0	3.0
300	470.5	443	422	3	10	3	8	285	300	3	1	3.1	3.2
350	520.5	493	472	3	10	4	10	285	300	3	1	3.3	3.4
400	570.5	543	522	4	12	4	10	385	400	3	1	3.5	3.6
450	620.5	593	572	4	12	5	12	385	400	3	1	3.7	3.7
500	670.5	643	622	5	14	5	12	485	500	3	1	3.8	3.9
550	720.5	693	672	5	14	6	14	485	500	3	1	4.0	4.1
600	770.5	743	722	6	16	6	14	585	600	3	1	4.2	4.3
650	820.5	793	772	6	16	7	16	585	600	3	1	4.4	4.4
700	870.5	843	822	7	18	7	16	685	700	3	1	4.5	4.6
750	920.5	893	872	7	18	8	18	685	700	3	1	4.7	4.8
800	970.5	943	922	8	20	8	18	785	800	3	1	4.9	4.9

5.12 Built-in Controller Specification RCP6S-SA6R Left Side-Mounted (Model: ML)

(Note) For Right Side-Mounted (model: MR), side-mounted motor will be on the right side in the drawing beneath.

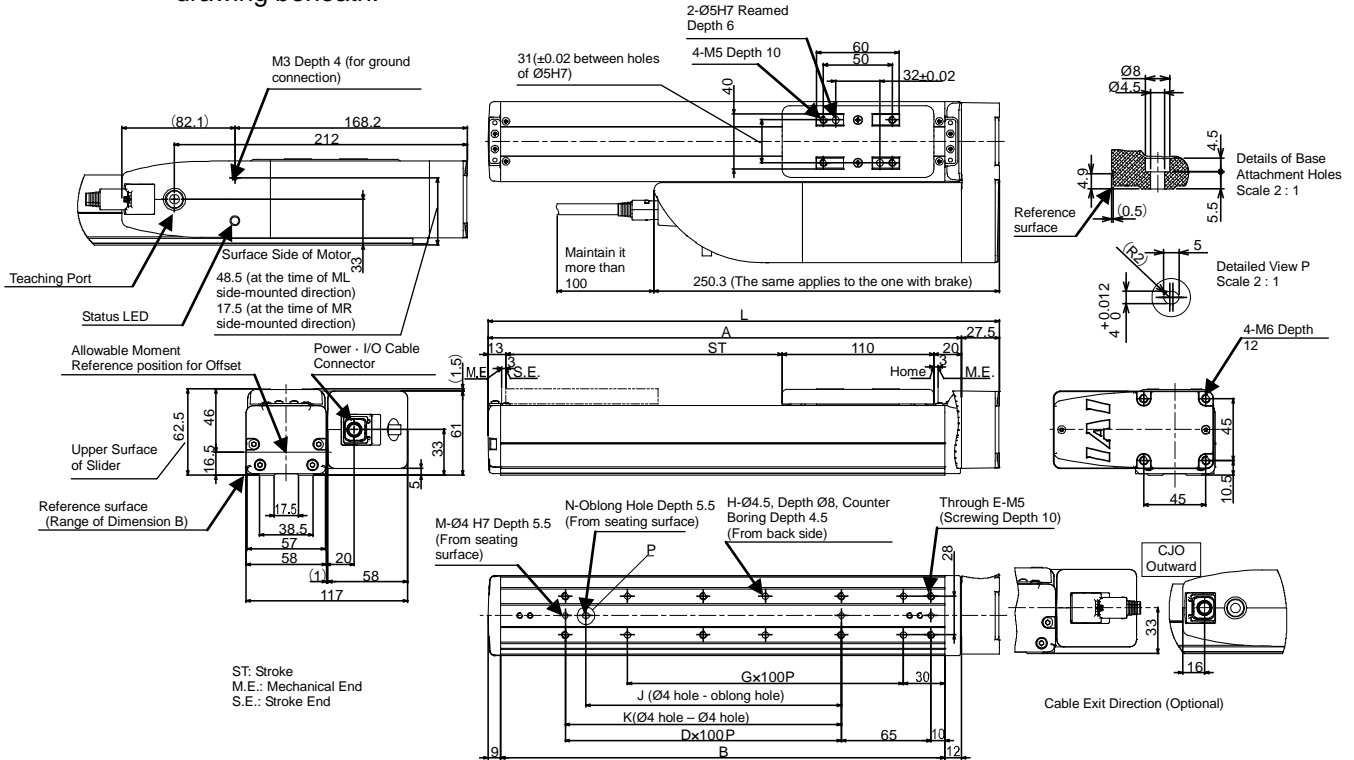

Stroke	L	A	B	D	E	G	H	J	K	M	N	Mass [kg]	
												W/o Brake	With Brake
50	220.5	193	172	0	4	1	4	0	0	2	0	2.4	2.5
100	270.5	243	222	1	6	1	4	85	100	3	1	2.6	2.7
150	320.5	293	272	1	6	2	6	85	100	3	1	2.8	2.8
200	370.5	343	322	2	8	2	6	185	200	3	1	2.9	3.0
250	420.5	393	372	2	8	3	8	185	200	3	1	3.1	3.2
300	470.5	443	422	3	10	3	8	285	300	3	1	3.3	3.4
350	520.5	493	472	3	10	4	10	285	300	3	1	3.5	3.5
400	570.5	543	522	4	12	4	10	385	400	3	1	3.6	3.7
450	620.5	593	572	4	12	5	12	385	400	3	1	3.8	3.9
500	670.5	643	622	5	14	5	12	485	500	3	1	4.0	4.1
550	720.5	693	672	5	14	6	14	485	500	3	1	4.2	4.2
600	770.5	743	722	6	16	6	14	585	600	3	1	4.3	4.4
650	820.5	793	772	6	16	7	16	585	600	3	1	4.5	4.6
700	870.5	843	822	7	18	7	16	685	700	3	1	4.7	4.7
750	920.5	893	872	7	18	8	18	685	700	3	1	4.8	4.9
800	970.5	943	922	8	20	8	18	785	800	3	1	5.0	5.1

5.13 Standard Specification RCP6-SA7R Left Side-Mounted (Model: ML)

(Note) For Right Side-Mounted (model: MR), side-mounted motor will be on the right side in the drawing beneath.

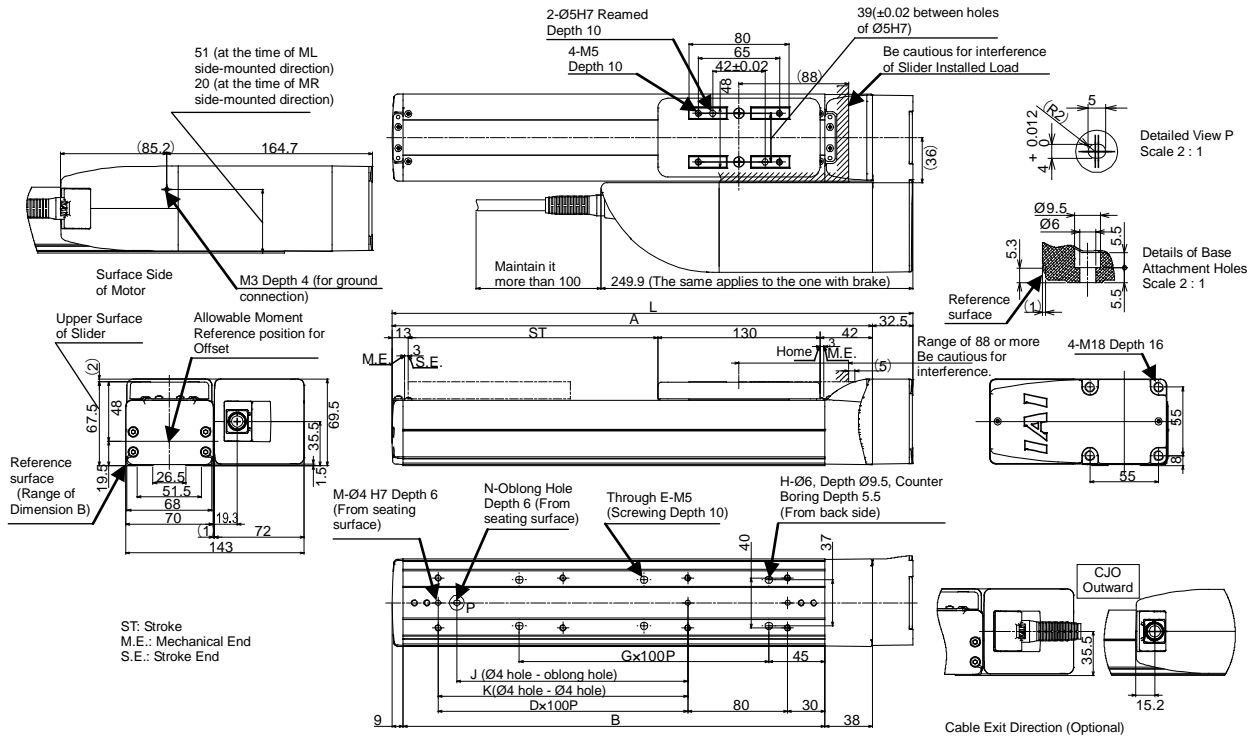

Stroke	L	A	B	D	E	G	H	J	K	M	N	Mass [kg]	
												W/o Brake	With Brake
50	267.5	235	188	0	4	1	4	0	0	2	0	4.2	4.3
100	317.5	285	238	1	6	1	4	85	0	2	1	4.4	4.5
150	367.5	335	288	1	6	2	6	85	100	3	1	4.6	4.7
200	417.5	385	338	2	8	2	6	185	200	3	1	4.9	5.0
250	467.5	435	388	2	8	3	8	185	200	3	1	5.1	5.2
300	517.5	485	438	3	10	3	8	285	300	3	1	5.3	5.4
350	567.5	535	488	3	10	4	10	285	300	3	1	5.5	5.6
400	617.5	585	538	4	12	4	10	385	400	3	1	5.8	5.9
450	667.5	635	588	4	12	5	12	385	400	3	1	6.0	6.1
500	717.5	685	638	5	14	5	12	485	500	3	1	6.2	6.3
550	767.5	735	688	5	14	6	14	485	500	3	1	6.4	6.6
600	817.5	785	738	6	16	6	14	585	600	3	1	6.7	6.8
650	867.5	835	788	6	16	7	16	585	600	3	1	6.9	7.0
700	917.5	885	838	7	18	7	16	685	700	3	1	7.1	7.2
750	967.5	935	888	7	18	8	18	685	700	3	1	7.3	7.5
800	1017.5	985	938	8	20	8	18	785	800	3	1	7.6	7.7

●Slider Spacer for SA7R (Optional Model: SS)

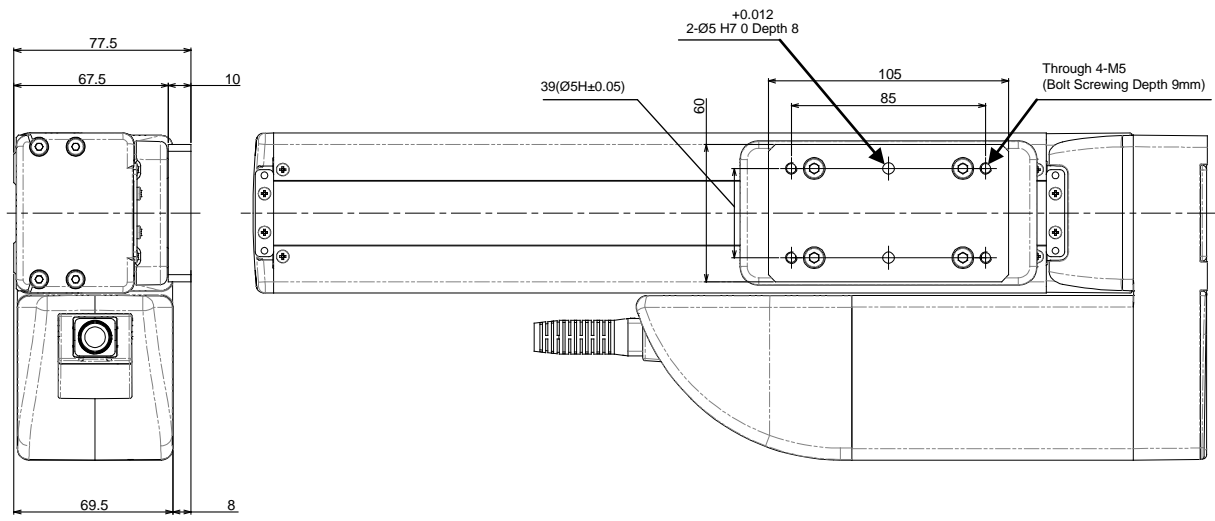

5.15 Standard Specification RCP6-SA8R Left Side-Mounted (Model: ML)

(Note) For Right Side-Mounted (model: MR), side-mounted motor will be on the right side in the drawing beneath.

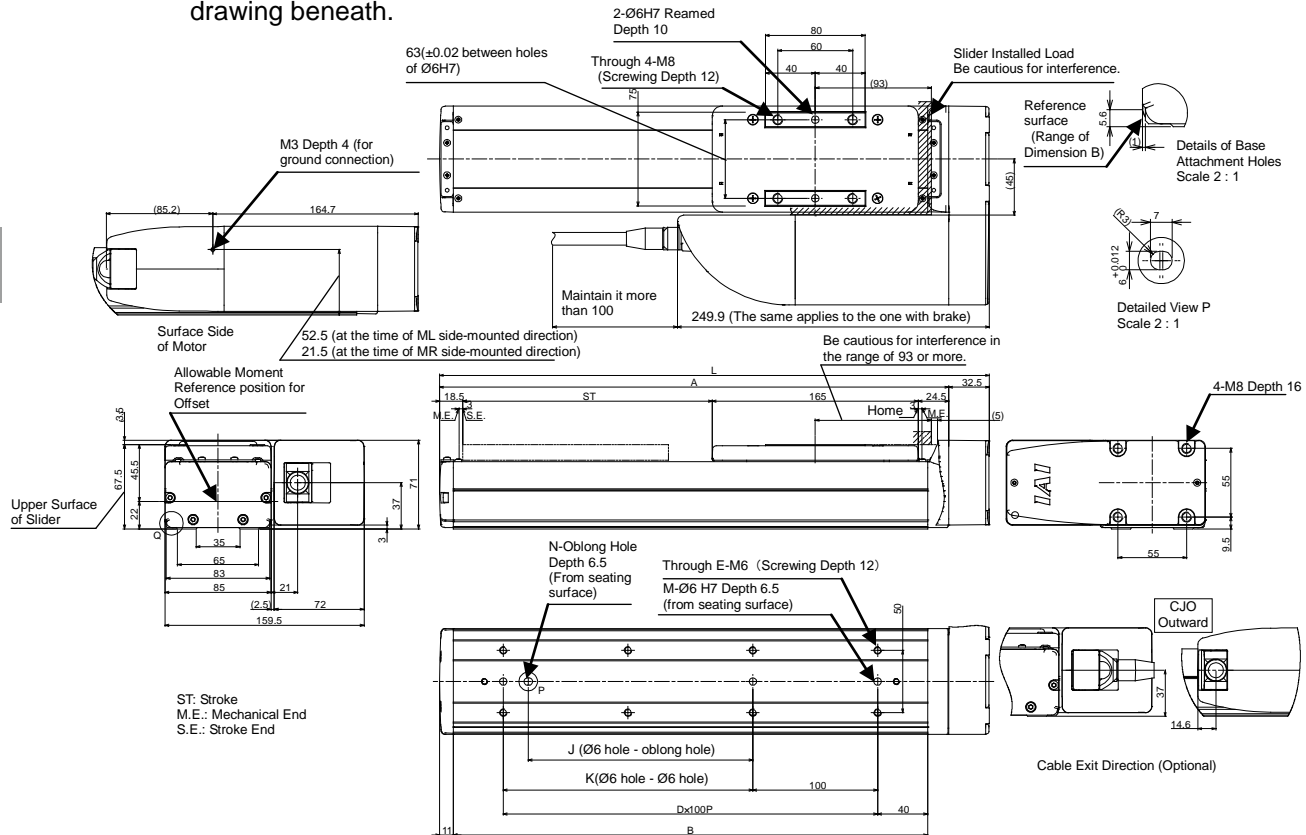

Stroke	L	A	B	D	E	J	K	M	N	Mass [kg]	
										W/o Brake	With Brake
50	290.5	258	230	1	4	0	0	2	0	4.8	5.0
100	340.5	308	280	2	6	0	100	3	0	5.1	5.3
150	390.5	358	330	2	6	80	100	3	1	5.4	5.5
200	440.5	408	380	3	8	180	200	3	1	5.7	5.8
250	490.5	458	430	3	8	180	200	3	1	5.9	6.1
300	540.5	508	480	4	10	280	300	3	1	6.2	6.4
350	590.5	558	530	4	10	280	300	3	1	6.5	6.7
400	640.5	608	580	5	12	380	400	3	1	6.8	6.9
450	690.5	658	630	5	12	380	400	3	1	7.1	7.2
500	740.5	708	680	6	14	480	500	3	1	7.4	7.5
550	790.5	758	730	6	14	480	500	3	1	7.6	7.8
600	840.5	808	780	7	16	580	600	3	1	7.9	8.1
650	890.5	858	830	7	16	580	600	3	1	8.2	8.4
700	940.5	908	880	8	18	680	700	3	1	8.5	8.6
750	990.5	958	930	8	18	680	700	3	1	8.8	8.9
800	1040.5	1008	980	9	20	780	800	3	1	9.0	9.2
850	1090.5	1058	1030	9	20	780	800	3	1	9.3	9.5
900	1140.5	1108	1080	10	22	880	900	3	1	9.6	9.8
950	1190.5	1158	1130	10	22	880	900	3	1	9.9	10.1
1000	1240.5	1208	1180	11	24	980	1000	3	1	10.2	10.3
1050	1290.5	1258	1230	11	24	980	1000	3	1	10.5	10.6
1100	1340.5	1308	1280	12	26	1080	1100	3	1	10.7	10.7

●Slider Spacer for SA8R (Optional Model: SS)

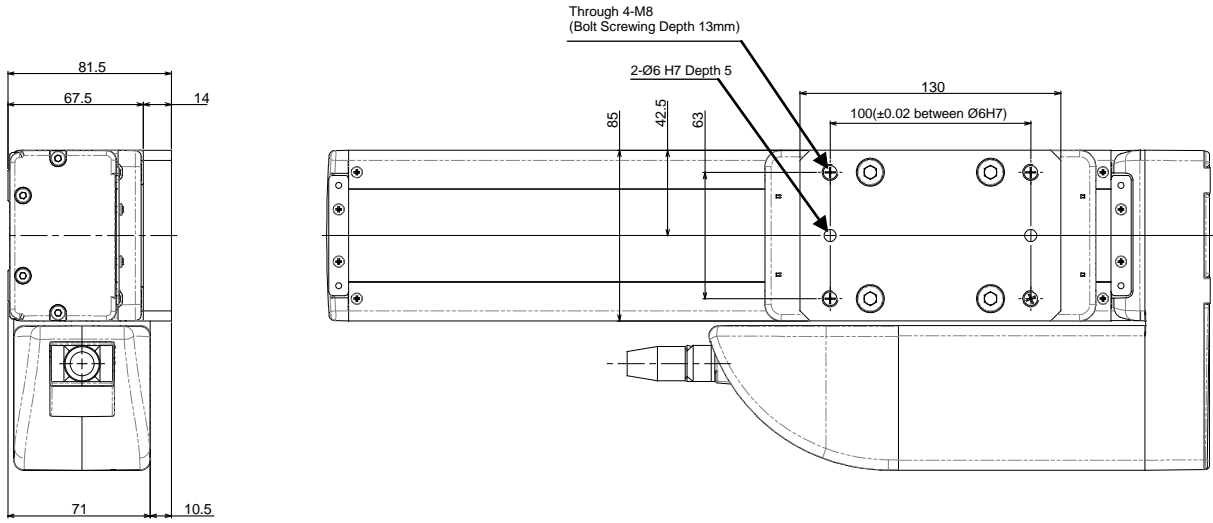

5.17 Cleanroom Type Standard Specification RCP6CR-SA4C Standard Specification RCP6-SA4C/SA4R (Option Model SR)

*Tube joints are not available in the slider roller (SR) specification.

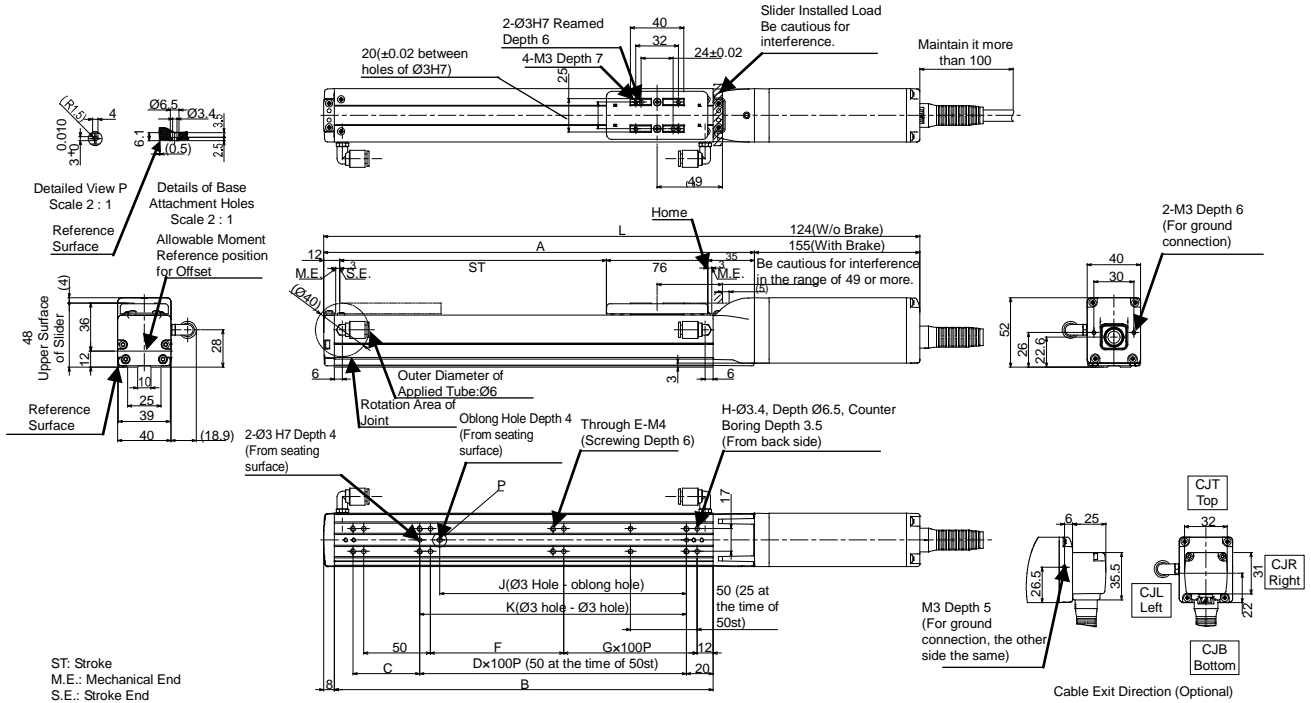

Stroke	L		A	B	C	D	E	F	G	H	J	K	Mass [kg]	
	W/o Brake	With Brake											W/o Brake	With Brake
50	297	328	173	134	50	0	6	50	0	8	35	50	1.1	1.3
100	347	378	223	184	50	1	6	100	0	8	85	100	1.2	1.4
150	397	428	273	234	100	1	6	50	1	10	85	100	1.3	1.5
200	447	478	323	284	50	2	8	100	1	10	185	200	1.4	1.5
250	497	528	373	334	100	2	8	50	2	12	185	200	1.5	1.6
300	547	578	423	384	50	3	10	100	2	12	285	300	1.6	1.7
350	597	628	473	434	100	3	10	50	3	14	285	300	1.7	1.8
400	647	678	523	484	50	4	12	100	3	14	385	400	1.7	1.9
450	697	728	573	534	100	4	12	50	4	16	385	400	1.8	2.0
500	747	778	623	584	50	5	14	100	4	16	485	500	1.9	2.1

(Note) L dimensions described in the table are those with no cable exit direction (option). For cable exit direction types (option), the dimensions are longer in 25mm.

5.18 Cleanroom Base Type Built-in Controller Specification RCP6SCR-SA4C Built-in Controller Specification RCP6S-SA4C/SA4R (Option Model SR)

*Tube joints are not available in the slider roller (SR) specification.

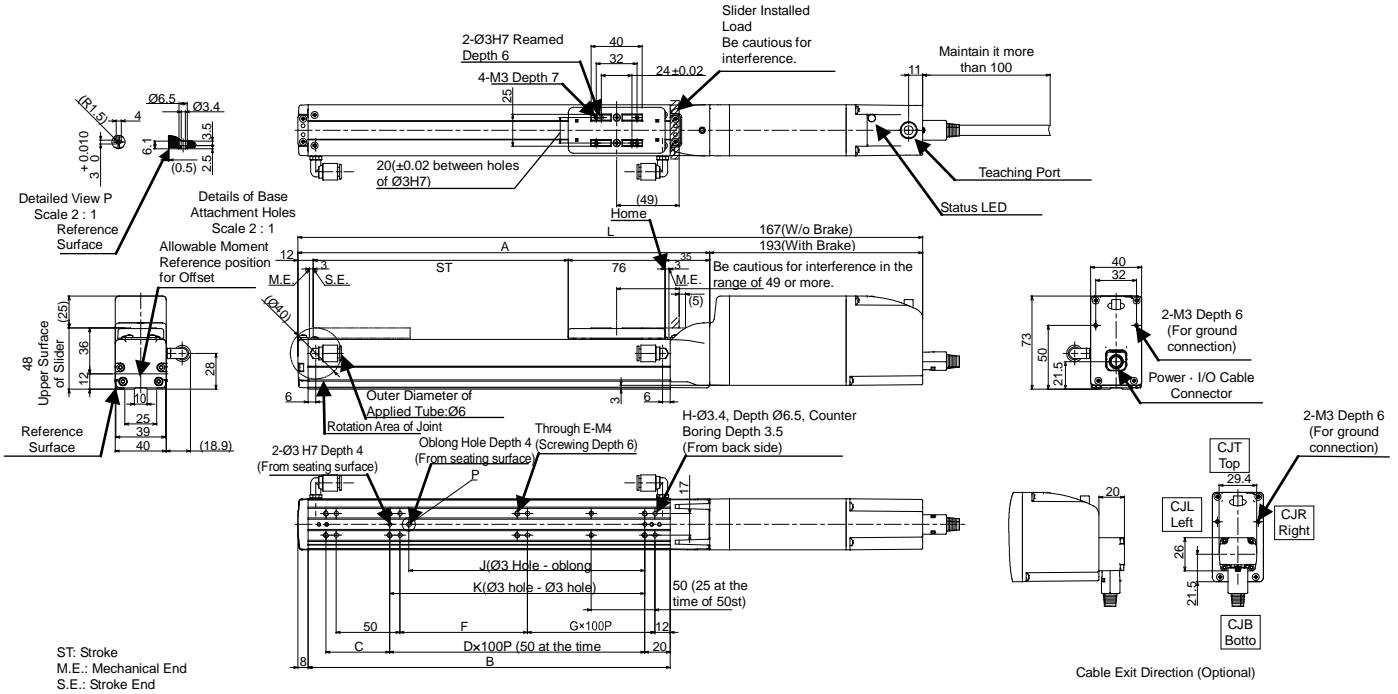

Stroke	L		A	B	C	D	E	F	G	H	J	K	Mass [kg]	
	W/o Brake	With Brake											W/o Brake	With Brake
50	340	366	173	134	50	0	6	50	0	8	35	50	1.3	1.5
100	390	416	223	184	50	1	6	100	0	8	85	100	1.4	1.6
150	440	466	273	234	100	1	6	50	1	10	85	100	1.5	1.6
200	490	516	323	284	50	2	8	100	1	10	185	200	1.6	1.7
250	540	566	373	334	100	2	8	50	2	12	185	200	1.7	1.8
300	590	616	423	384	50	3	10	100	2	12	285	300	1.8	1.9
350	640	666	473	434	100	3	10	50	3	14	285	300	1.8	2.0
400	690	716	523	484	50	4	12	100	3	14	385	400	1.9	2.1
450	740	766	573	534	100	4	12	50	4	16	385	400	2.0	2.2
500	790	816	623	584	50	5	14	100	4	16	485	500	2.1	2.3

(Note) L dimensions described in the table are those with no cable exit direction (option). For cable exit direction types (option), the dimensions are longer in 20mm.

5.19 Cleanroom Type Standard Specification RCP6CR-SA6C Standard Specification RCP6-SA6C/SA6R (Option Model SR) Tube joints are not available in the slider (SR) specification.

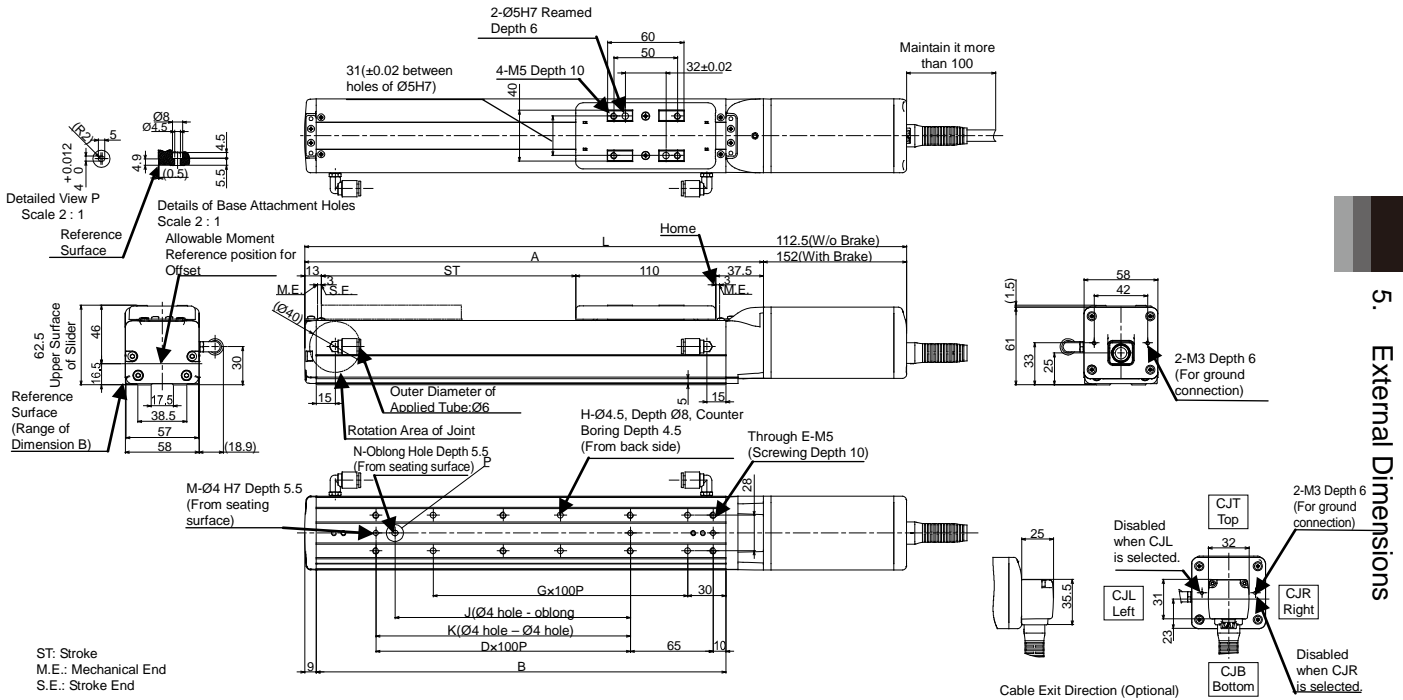

5. External Dimensions

Stroke	L		A	B	D	E	G	H	J	K	M	N	Mass [kg]	
	W/o Brake	With Brake											W/o Brake	With Brake
50	323	362.5	210.5	172	0	4	1	4	0	0	2	0	2.0	2.2
100	373	412.5	260.5	222	1	6	1	4	85	100	3	1	2.2	2.4
150	423	462.5	310.5	272	1	6	2	6	85	100	3	1	2.3	2.6
200	473	512.5	360.5	322	2	8	2	6	185	200	3	1	2.5	2.8
250	523	562.5	410.5	372	2	8	3	8	185	200	3	1	2.7	2.9
300	573	612.5	460.5	422	3	10	3	8	285	300	3	1	2.8	3.1
350	623	662.5	510.5	472	3	10	4	10	285	300	3	1	3.0	3.3
400	673	712.5	560.5	522	4	12	4	10	385	400	3	1	3.2	3.4
450	723	762.5	610.5	572	4	12	5	12	385	400	3	1	3.4	3.6
500	773	812.5	660.5	622	5	14	5	12	485	500	3	1	3.5	3.8
550	823	862.5	710.5	672	5	14	6	14	485	500	3	1	3.7	4.0
600	873	912.5	760.5	722	6	16	6	14	585	600	3	1	3.9	4.1
650	923	962.5	810.5	772	6	16	7	16	585	600	3	1	4.1	4.3
700	973	1012.5	860.5	822	7	18	7	16	685	700	3	1	4.2	4.5
750	1023	1062.5	910.5	872	7	18	8	18	685	700	3	1	4.4	4.6
800	1073	1112.5	960.5	922	8	20	8	18	785	800	3	1	4.6	4.8

(Note) L dimensions described in the table are those with no cable exit direction (option). For cable exit direction types (option), the dimensions are longer in 25mm.

5.20 Cleanroom Type Built-in Controller RCP6SCR-SA6C

Built-in Controller Specification RCP6S-SA6C/SA6R (Option Model SR)

*Tube joints are not available in the slider roller (SR) specification.

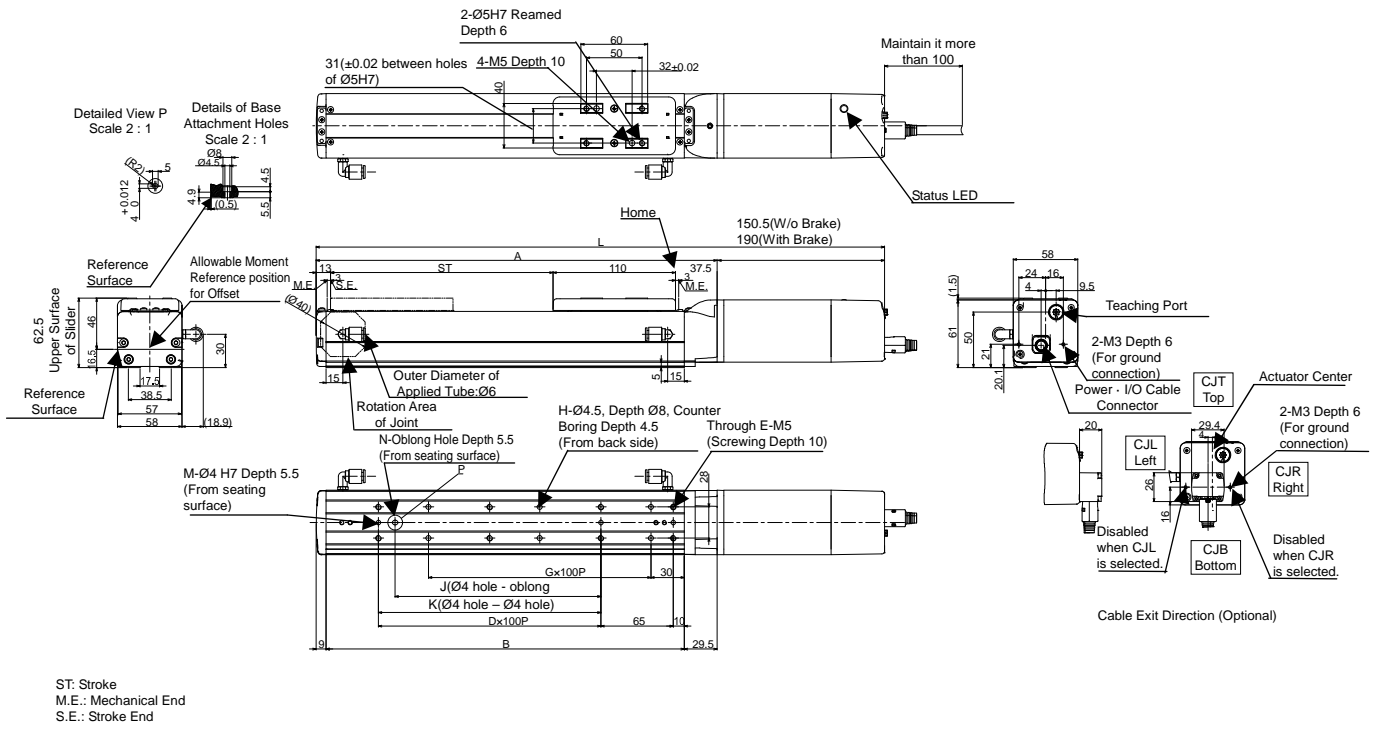

Stroke	L		A	B	D	E	G	H	J	K	M	N	Mass [kg]	
	W/o Brake	With Brake											W/o Brake	With Brake
50	361	400.5	210.5	172	0	4	1	4	0	0	2	0	2.1	2.4
100	411	450.5	260.5	222	1	6	1	4	85	100	3	1	2.3	2.5
150	461	500.5	310.5	272	1	6	2	6	85	100	3	1	2.5	2.7
200	511	550.5	360.5	322	2	8	2	6	185	200	3	1	2.6	2.9
250	561	600.5	410.5	372	2	8	3	8	185	200	3	1	2.8	3.1
300	611	650.5	460.5	422	3	10	3	8	285	300	3	1	3.0	3.2
350	661	700.5	510.5	472	3	10	4	10	285	300	3	1	3.2	3.4
400	711	750.5	560.5	522	4	12	4	10	385	400	3	1	3.3	3.6
450	761	800.5	610.5	572	4	12	5	12	385	400	3	1	3.5	3.8
500	811	850.5	660.5	622	5	14	5	12	485	500	3	1	3.7	3.9
550	861	900.5	710.5	672	5	14	6	14	485	500	3	1	3.9	4.1
600	911	950.5	760.5	722	6	16	6	14	585	600	3	1	4.0	4.3
650	961	1000.5	810.5	772	6	16	7	16	585	600	3	1	4.2	4.4
700	1011	1050.5	860.5	822	7	18	7	16	685	700	3	1	4.4	4.6
750	1061	1100.5	910.5	872	7	18	8	18	685	700	3	1	4.6	4.8
800	1111	1150.5	960.5	922	8	20	8	18	785	800	3	1	4.7	4.9

(Note) L dimensions described in the table are those with no cable exit direction (option). For cable exit direction types (option), the dimensions are longer in 20mm.

5.21 Cleanroom Standard Specification RCP6CR-SA7C Standard Specification RCP6-SA7C/SA7R (Option Model SR)

*Tube joints are not available in the slider roller (SR) specification.

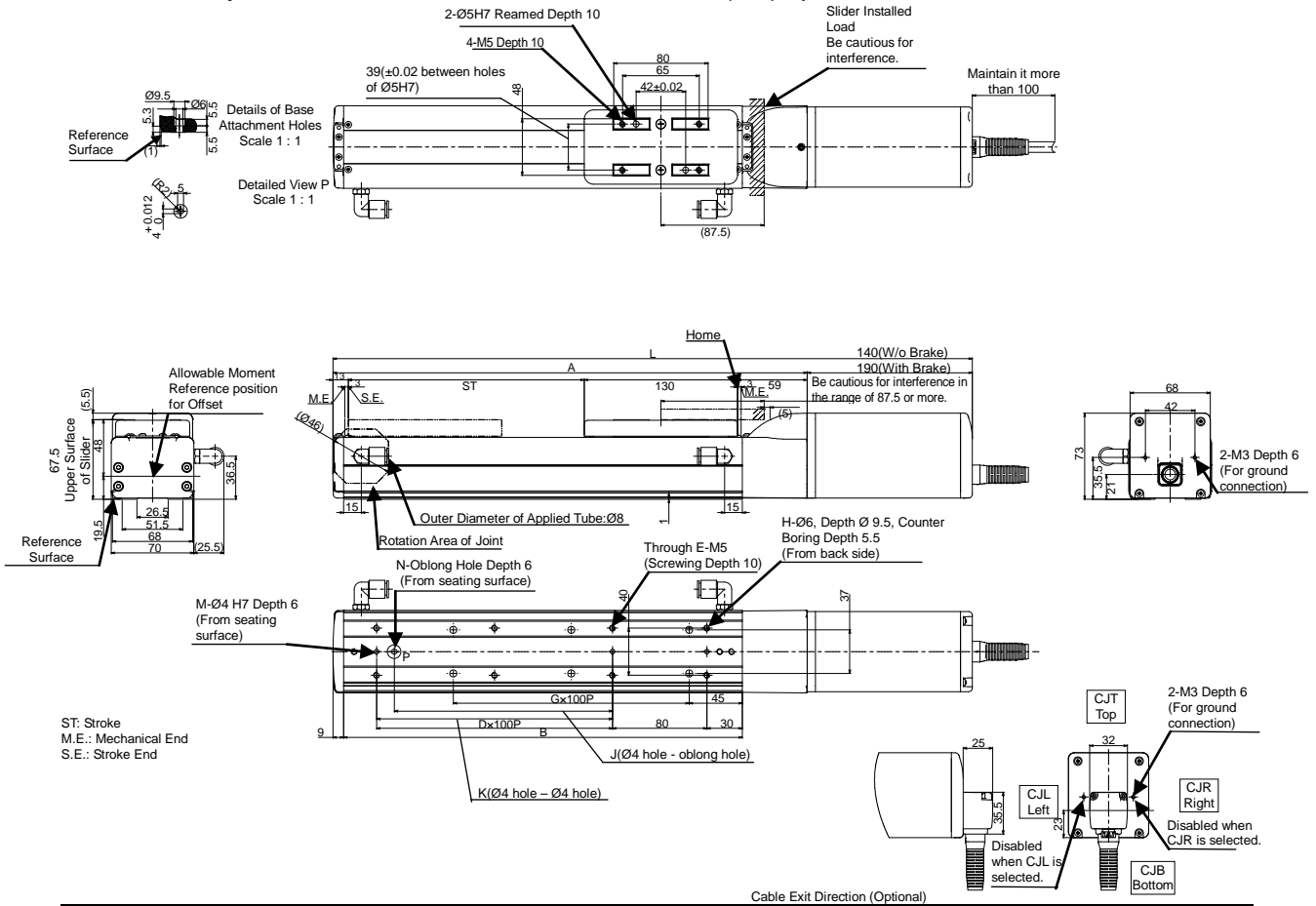

Cable Exit Direction (Optional)

Stroke	L		A	B	D	E	G	H	J	K	M	N	Mass [kg]	
	W/o Brake	With Brake											W/o Brake	With Brake
50	392	442	252	188	0	4	1	4	0	0	2	0	3.6	4.0
100	442	492	302	238	1	6	1	4	85	0	2	1	3.8	4.2
150	492	542	352	288	1	6	2	6	85	100	3	1	4.0	4.5
200	542	592	402	338	2	8	2	6	185	200	3	1	4.3	4.7
250	592	642	452	388	2	8	3	8	185	200	3	1	4.5	4.9
300	642	692	502	438	3	10	3	8	285	300	3	1	4.7	5.1
350	692	742	552	488	3	10	4	10	285	300	3	1	4.9	5.4
400	742	792	602	538	4	12	4	10	385	400	3	1	5.2	5.6
450	792	842	652	588	4	12	5	12	385	400	3	1	5.4	5.8
500	842	892	702	638	5	14	5	12	485	500	3	1	5.6	6.1
550	892	942	752	688	5	14	6	14	485	500	3	1	5.9	6.3
600	942	992	802	738	6	16	6	14	585	600	3	1	6.1	6.5
650	992	1042	852	788	6	16	7	16	585	600	3	1	6.3	6.7
700	1042	1092	902	838	7	18	7	16	685	700	3	1	6.5	7.0
750	1092	1142	952	888	7	18	8	18	685	700	3	1	6.8	7.2
800	1142	1192	1002	938	8	20	8	18	785	800	3	1	7.0	7.4

(Note) L dimensions described in the table are those with no cable exit direction (option). For cable exit direction types (option), the dimensions are longer in 25mm.

5.22 Cleanroom View Type Built-in Controller Specification RCP6SCR-SA7C Built-in Controller Specification RCP6S-SA7C/SA7R (Option Model SR)

*Tube joints are not available in the slider roller (SR) specification.

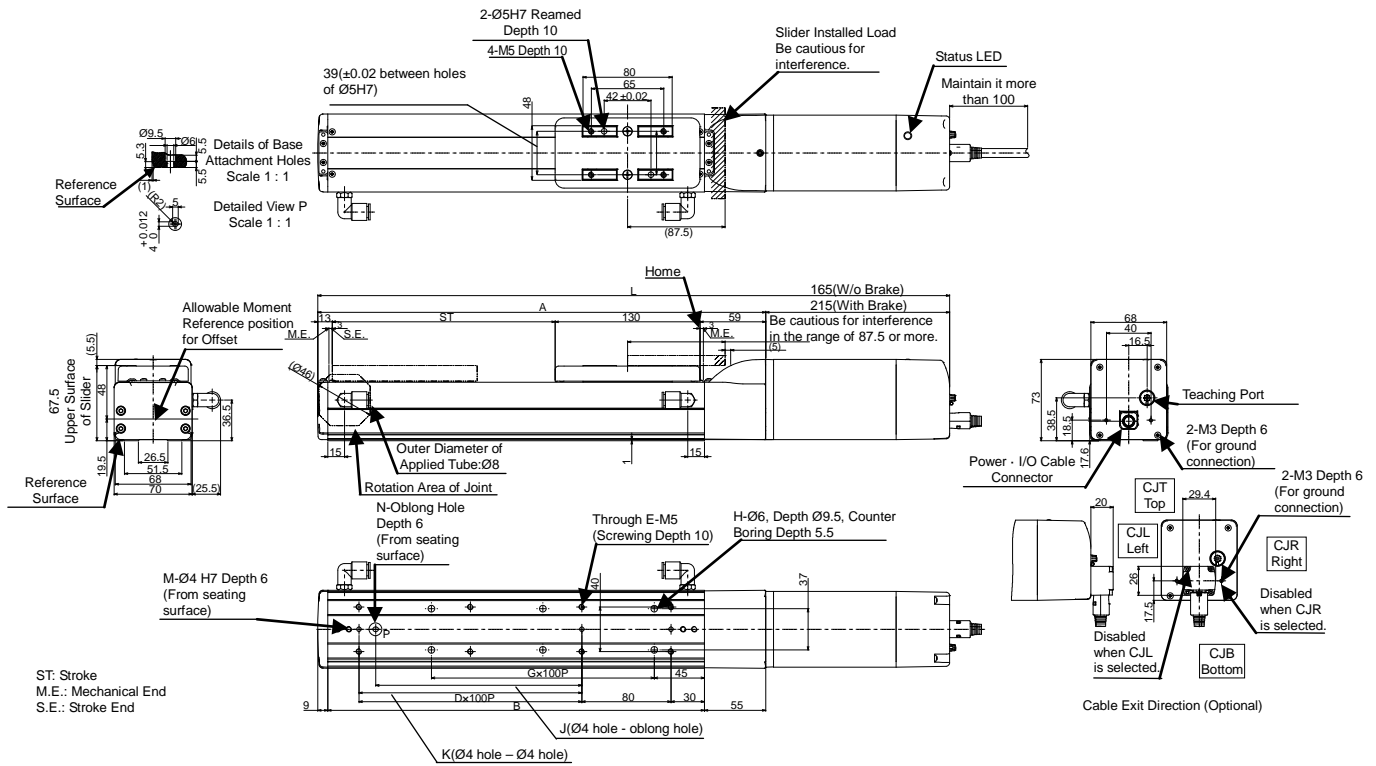

Stroke	L		A	B	D	E	G	H	J	K	M	N	Mass [kg]	
	W/o Brake	With Brake											W/o Brake	With Brake
50	417	467	252	188	0	4	1	4	0	0	2	0	3.8	4.2
100	467	517	302	238	1	6	1	4	85	0	2	1	4.0	4.4
150	517	567	352	288	1	6	2	6	85	100	3	1	4.2	4.6
200	567	617	402	338	2	8	2	6	185	200	3	1	4.4	4.9
250	617	667	452	388	2	8	3	8	185	200	3	1	4.7	5.1
300	667	717	502	438	3	10	3	8	285	300	3	1	4.9	5.3
350	717	767	552	488	3	10	4	10	285	300	3	1	5.1	5.6
400	767	817	602	538	4	12	4	10	385	400	3	1	5.3	5.8
450	817	867	652	588	4	12	5	12	385	400	3	1	5.6	6.0
500	867	917	702	638	5	14	5	12	485	500	3	1	5.8	6.2
550	917	967	752	688	5	14	6	14	485	500	3	1	6.0	6.5
600	967	1017	802	738	6	16	6	14	585	600	3	1	6.3	6.7
650	1017	1067	852	788	6	16	7	16	585	600	3	1	6.5	6.9
700	1067	1117	902	838	7	18	7	16	685	700	3	1	6.7	7.1
750	1117	1167	952	888	7	18	8	18	685	700	3	1	6.9	7.4
800	1167	1217	1002	938	8	20	8	18	785	800	3	1	7.2	7.6

(Note) L dimensions described in the table are those with no cable exit direction (option). For cable exit direction types (option), the dimensions are longer in 20mm.

5.23 Cleanroom Type Standard Specification RCP6CR-SA8C Standard Specification RCP6-SA8C/SA8R (Option Model SR)

*Tube joints are not available in the slider roller (SR) specification.

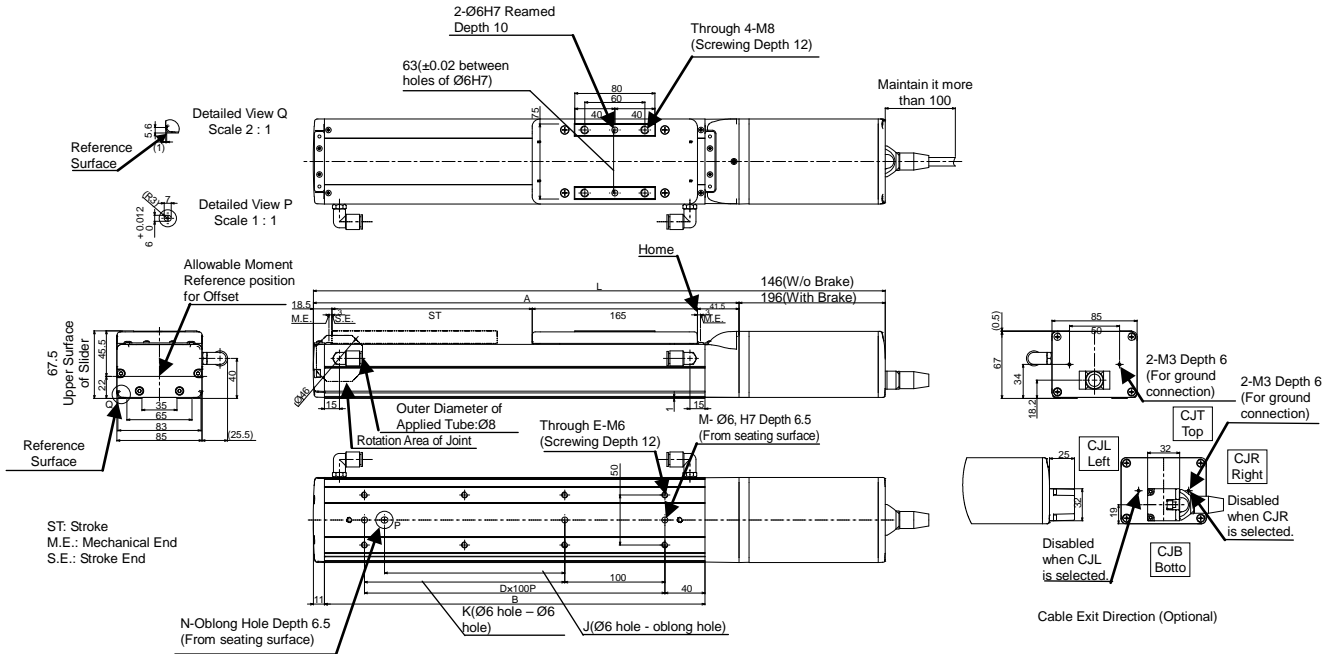

Stroke	L		A	B	D	E	J	K	M	N	Mass [kg]	
	W/o Brake	With Brake									W/o Brake	With Brake
50	421	471	275	230	1	4	0	0	2	0	4.5	5.0
100	471	521	325	280	2	6	0	100	3	0	4.7	5.2
150	521	571	375	330	2	6	80	100	3	1	5.0	5.5
200	571	621	425	380	3	8	180	200	3	1	5.3	5.8
250	621	671	475	430	3	8	180	200	3	1	5.5	6.1
300	671	721	525	480	4	10	280	300	3	1	5.8	6.3
350	721	771	575	530	4	10	280	300	3	1	6.1	6.6
400	771	821	625	580	5	12	380	400	3	1	6.4	6.9
450	821	871	675	630	5	12	380	400	3	1	6.6	7.1
500	871	921	725	680	6	14	480	500	3	1	6.9	7.4
550	921	971	775	730	6	14	480	500	3	1	7.2	7.7
600	971	1021	825	780	7	16	580	600	3	1	7.5	8.0
650	1021	1071	875	830	7	16	580	600	3	1	7.7	8.2
700	1071	1121	925	880	8	18	680	700	3	1	8.0	8.5
750	1121	1171	975	930	8	18	680	700	3	1	8.3	8.8
800	1171	1221	1025	980	9	20	780	800	3	1	8.5	9.1
850	1221	1271	1075	1030	9	20	780	800	3	1	8.8	9.3
900	1271	1321	1125	1080	10	22	880	900	3	1	9.1	9.6
950	1321	1371	1175	1130	10	22	880	900	3	1	9.4	9.9
1000	1371	1421	1225	1180	11	24	980	1000	3	1	9.6	10.1
1050	1421	1471	1275	1230	11	24	980	1000	3	1	9.9	10.4
1100	1471	1521	1325	1280	12	26	1080	1100	3	1	10.2	10.7

(Note) L dimensions described in the table are those with no cable exit direction (option). For cable exit direction types (option), the dimensions are longer in 25mm.

5.25 Standard Specification Double Slider Specification RCP6-SA4C (Option Model W)

* The dimensions of the double slider are the same as the side-mounted motor type RCP6-SA4R and the built-in controller specification RCP6S-SA4C and RCP6S-SA4R.

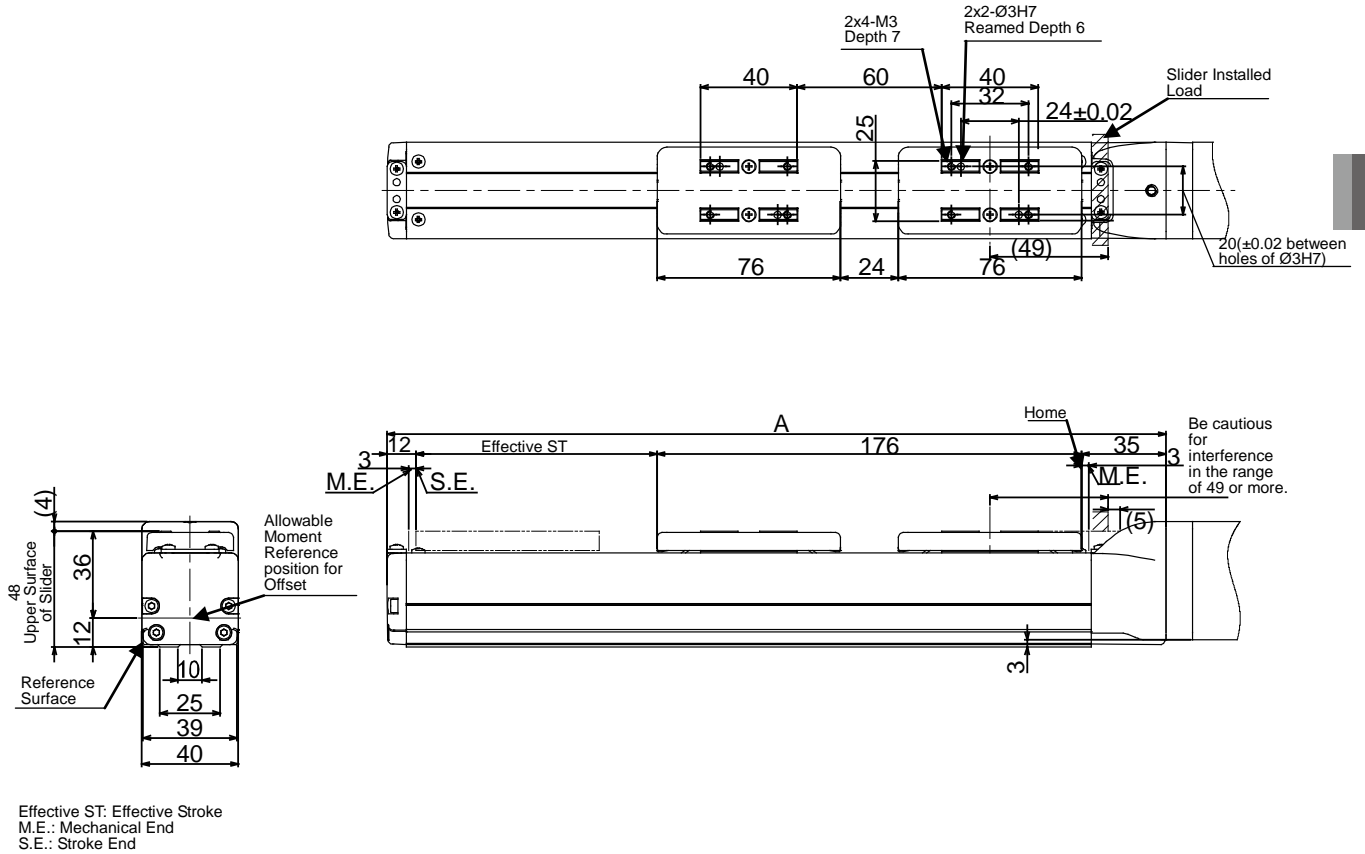

Nominal Stroke	Effective Stroke	A
150	50	273
200	100	323
250	150	373
300	200	423
350	250	473
400	300	523
450	350	573
500	400	623

5.26 Standard Specification Double Slider Specification RCP6-SA6C (Option Model W)

* The dimensions of the double slider are the same as the side-mounted motor type RCP6-SA6R and the built-in controller specification RCP6S-SA6C and RCP6S-SA6R.

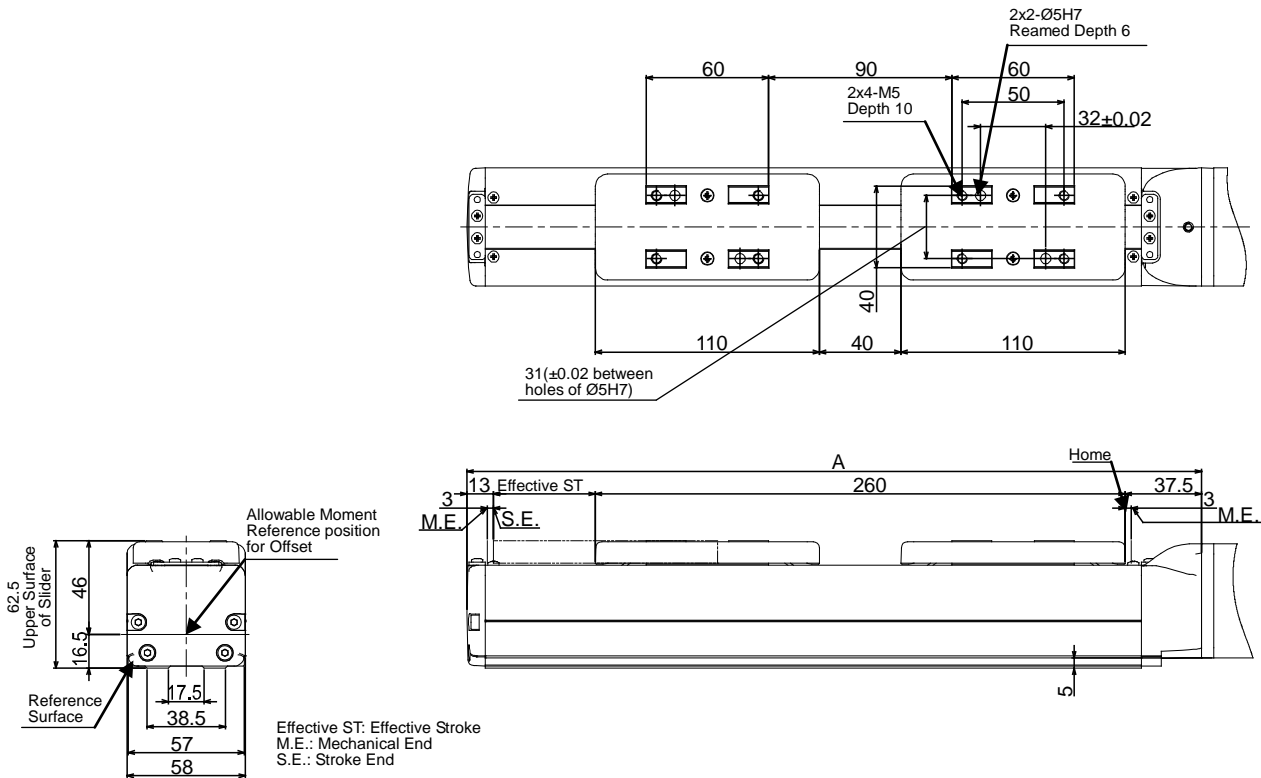

Nominal Stroke	Effective Stroke	A
200	50	360.5
250	100	410.5
300	150	460.5
350	200	510.5
400	250	560.5
450	300	610.5
500	350	660.5
550	400	710.5
600	450	760.5
650	500	810.5
700	550	860.5
750	600	910.5
800	650	960.5

5.29 Cleanroom Type Standard Specification Double Slider Specification RCP6CR-SA4C (Option Model W)

* The dimensions of the double slider are the same as the built-in controller RCP6SCR-SA4C.

As is the case with the standard specification RCP6-SA4C/SA4R and with the built-in controller RCP6S-SA4C/SA4R slider roller (SR) specification, tube joints are not available.

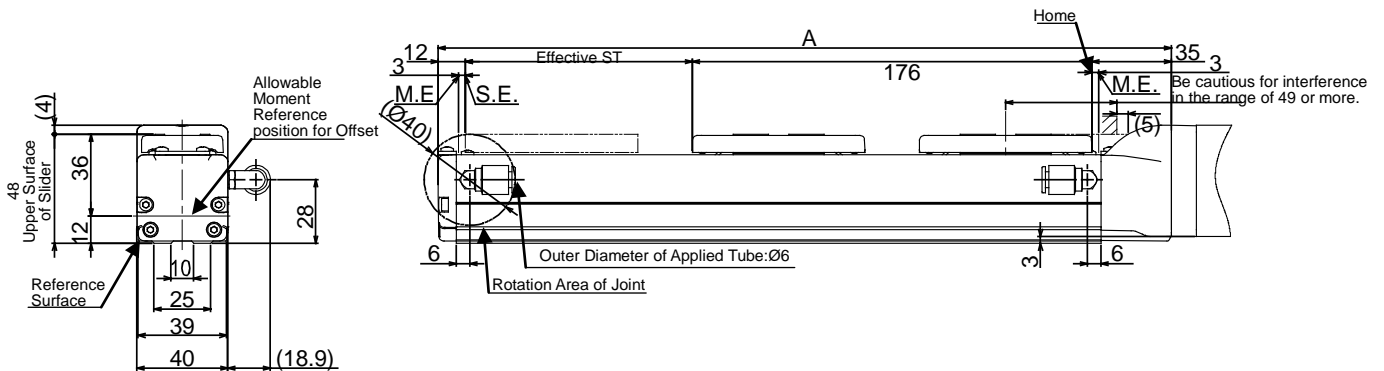
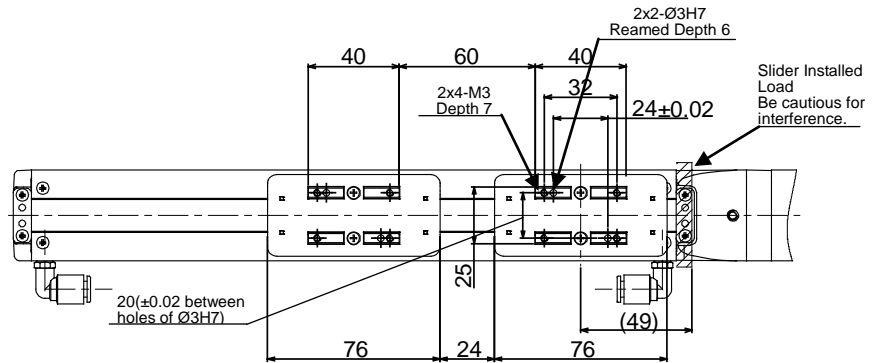

Effective ST: Effective Stroke
M.E.: Mechanical End
S.E.: Stroke End

Nominal Stroke	Effective Stroke	A
150	50	273
200	100	323
250	150	373
300	200	423
350	250	473
400	300	523
450	350	573
500	400	623

5.30 Cleanroom Type Standard Specification Double Slider Specification RCP6CR-SA6C (Option Model W)

* The dimensions of the double slider are the same as the built-in controller RCP6SCR-SA6C.

As is the case with the standard specification RCP6-SA6C/SA6R and with the built-in controller RCP6S-SA6C/SA6R slider roller (SR) specification, tube joints are not available.

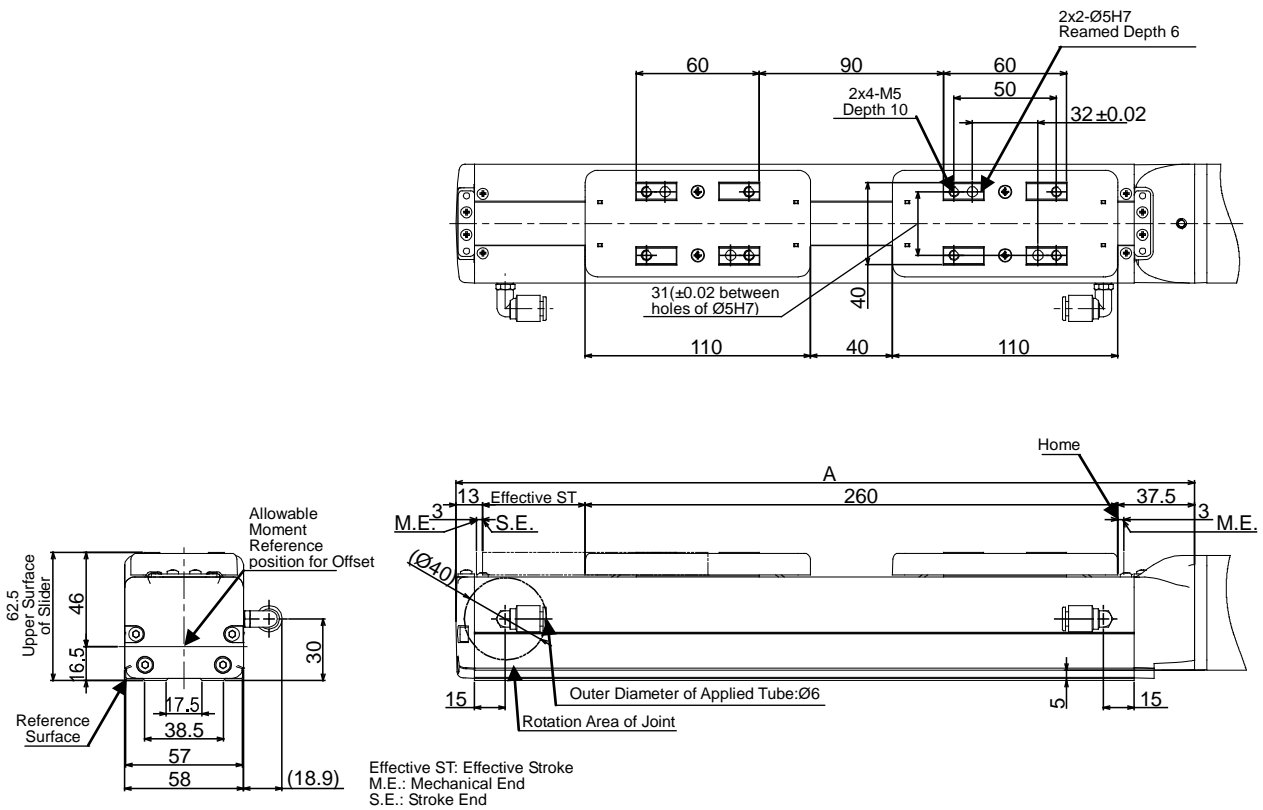

Nominal Stroke	Effective Stroke	A
200	50	360.5
250	100	410.5
300	150	460.5
350	200	510.5
400	250	560.5
450	300	610.5
500	350	660.5
550	400	710.5
600	450	760.5
650	500	810.5
700	550	860.5
750	600	910.5
800	650	960.5

5.31 Cleanroom Type Standard Specification Double Slider Specification RCP6CR-SA7C (Option Model W)

* The dimensions of the double slider are the same as the built-in controller RCP6SCR-SA7C.

As is the case with the standard specification RCP6-SA7C/SA7R and with the built-in controller RCP6S-SA7C/SA7R slider roller (SR) specification, tube joints are not available.

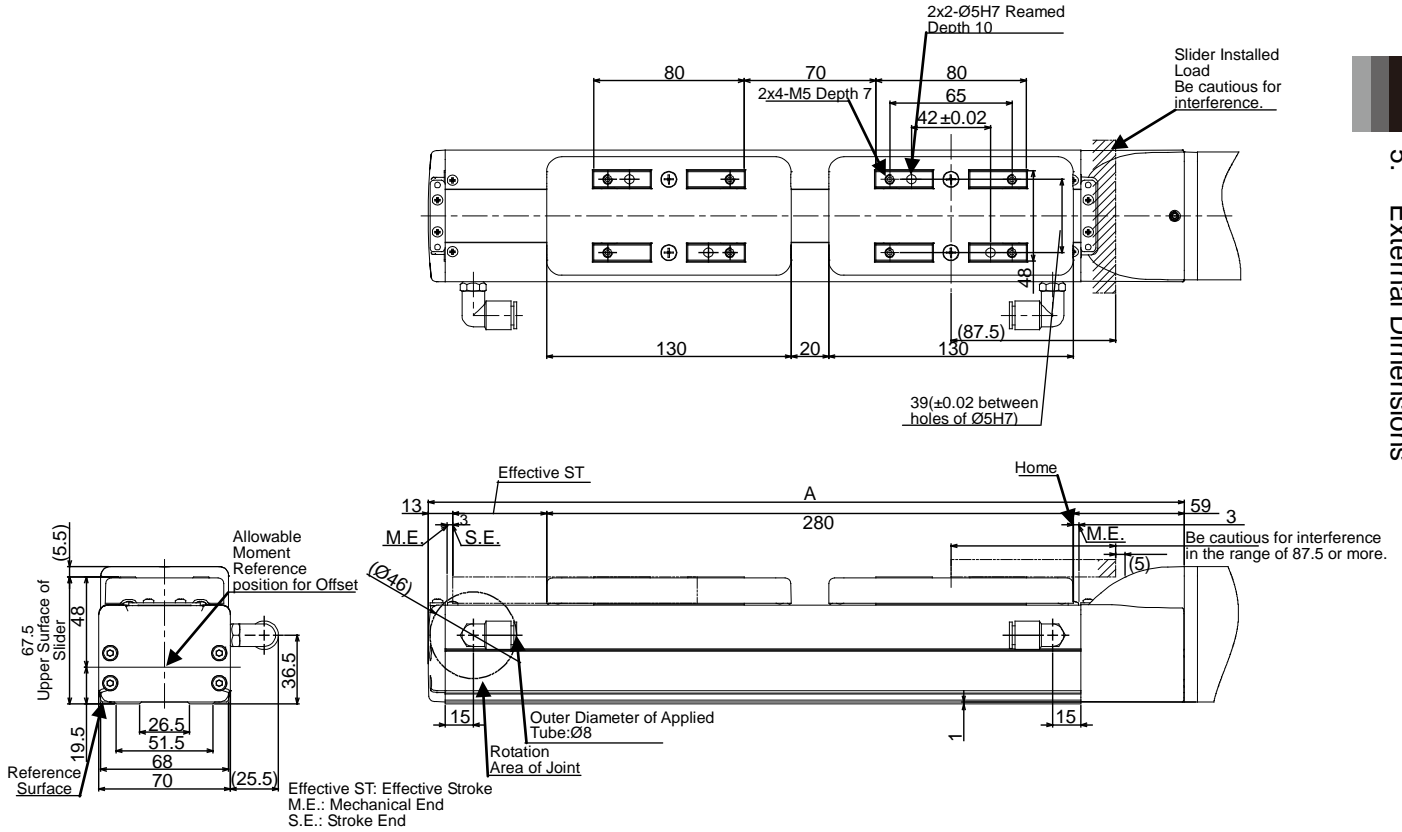

Nominal Stroke	Effective Stroke	A
200	50	402
250	100	452
300	150	502
350	200	552
400	250	602
450	300	652
500	350	702
550	400	752
600	450	802
650	500	852
700	550	902
750	600	952
800	650	1002

5.32 Cleanroom Type Standard Specification Double Slider Specification RCP6CR-SA8C (Option Model W)

* The dimensions of the double slider are the same as the built-in controller RCP6SCR-SA8C.

As is the case with the standard specification RCP6-SA8C/SA8R and with the built-in controller RCP6S-SA8C/SA8R slider roller (SR) specification, tube joints are not available.

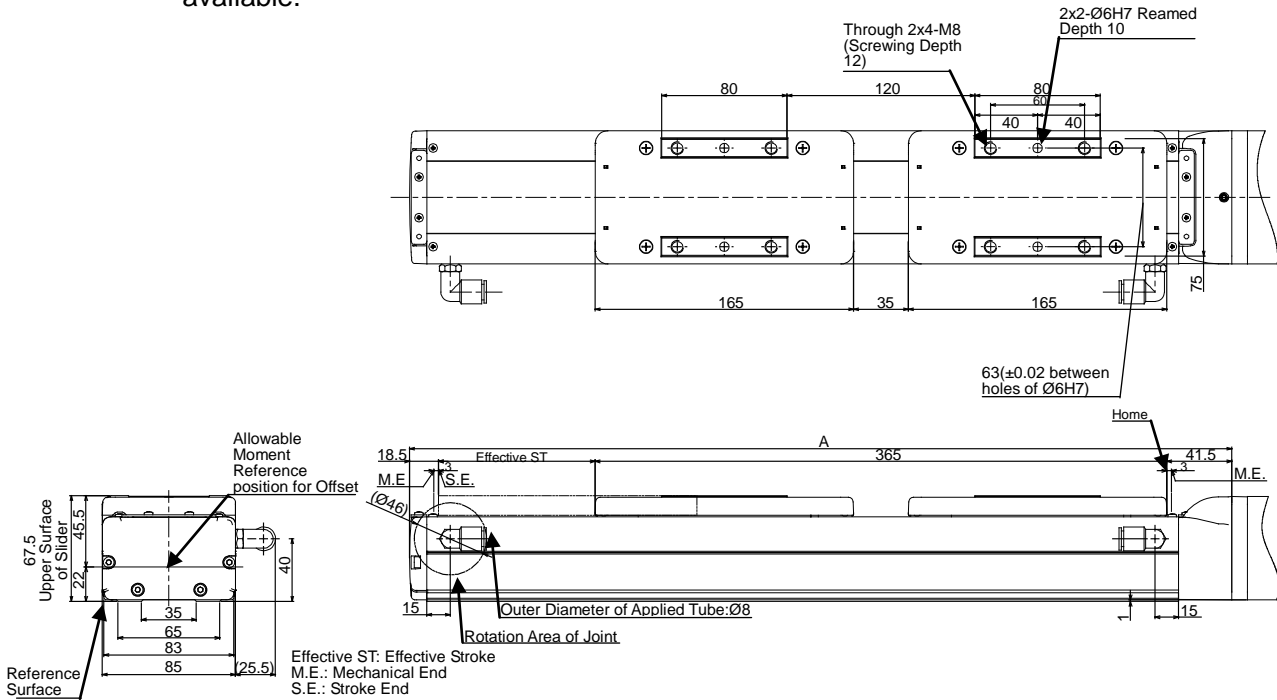

Nominal Stroke	Effective Stroke	A
250	50	475
300	100	525
350	150	575
400	200	625
450	250	675
500	300	725
550	350	775
600	400	825
650	450	875
700	500	925
750	550	975
800	600	1025
850	650	1075
900	700	1125
950	750	1175
1000	800	1225
1050	850	1275
1100	900	1325

6. Life

The mechanical life of the actuator is represented by that of the guide receiving the greatest moment load.

Operation life of the linear guide is to be determined by the total driving distance which can reach without having 90% flaking (peeling on rail surface).

Operation life can be figured out with the calculation method shown below.

6.1 How to Calculate Operation Life

For the operation life of the linear guide, use the dynamic allowable moment stated in 1.2 Specifications, and figure out with the formula below.

$$L = \left(\frac{C_M}{M} \right)^3 \cdot 5000\text{km}$$

L : Operation life (km) C_M : Allowable dynamic moment (N·m)

M : Moment to work (N·m) 5000km : Standard rated life of ROBO Cylinder

In addition, have a calculation for the drop of life with the formula below if there is a concern that the life could drop due to the condition of vibration or way to be attached.

$$L = \left(\frac{C_M}{M} \cdot \frac{f_{ws}}{f_w} \cdot \frac{1}{f_\alpha} \right)^3 \cdot 5000\text{km}$$

L : Operation life (km) C_M : Allowable dynamic moment (N·m)

M : Moment to work (N·m)

f_{ws} : Standard operational coefficient f_w : Load coefficient f_α : Attachment coefficient

5000km : Standard rated life of ROBO Cylinder

Explained below is regarding the standard operational coefficient f_{ws} , load coefficient f_w and attachment coefficient f_α .

Refer to the contents below to set them up.

[Standard operational coefficient f_{ws}]

For ROBO Cylinders described in this manual, $f_{ws} = 1.2$. It is a coefficient defined for each model, some models such as RCS3 high-speed type is 1.35.

[Load coefficient f_w]

It is a coefficient to consider the life drop due to operational conditions.

Load coefficient f_w	Operation Condition	Reference for acceleration/deceleration
1.0 to 1.5	Small vibration or impact in slow operation	1.0G or less

[Attachment coefficient f_a]

Attachment coefficient f_a is a coefficient to consider the life drop due to the condition of actuator attachment.

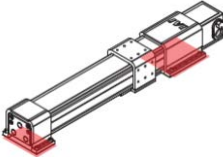
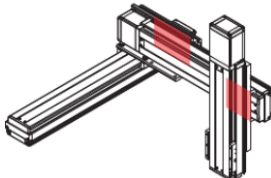
Attachment coefficient f_a	1.0	1.2	1.5
	Attachment in whole area	Attachment on both ends	Attachment on spots
Attached condition			

- * As the figures are those in common for each manual, they are not for RCP5 Slider Type. Replace to figures for RCP6 Slider Type and select the attachment coefficient.
- * Even when in attachment in whole area, and the actuator is seated in the whole length of the product, select 1.2 or 1.5 for the attachment coefficient depending on the position of screw fixing.
- * For attachment in whole area, use all of the tapped holes (counterbored holes) on the seat surface to fix.

6.2 Operation Life

The operation life depends on the moment to work. With light load, it will be longer than 5,000km, the standard rated life. With no consideration of vibration and attachment condition, the operation life is 40,000km according to the calculation with formula in the previous page under assumption that 0.5 C_M (half of dynamic allowable moment) of moment is applied on. It shows that it can be 8 times longer than the standard rated life, which is 5,000km.

7. Warranty

7.1 Warranty Period

One of the following periods, whichever is shorter:

- 18 months after shipment from IAI
- 12 months after delivery to the specified location
- 2,500 hours of operation

7.2 Scope of the Warranty

Our products are covered by warranty when all of the following conditions are met. Faulty products covered by warranty will be replaced or repaired free of charge:

- (1) The breakdown or problem in question pertains to our product as delivered by us or our authorized dealer.
- (2) The breakdown or problem in question occurred during the warranty period.
- (3) The breakdown or problem in question occurred while the product was in use for an appropriate purpose under the conditions and environment of use specified in the instruction manual and catalog.
- (4) The breakdown or problem in question was caused by a specification defect or problem, or by a quality issue with our product.

Note that breakdowns due to any of the following reasons are excluded from the scope of warranty:

- [1] Anything other than our product
- [2] Modification or repair performed by a party other than us (unless we have approved such modification or repair)
- [3] Anything that could not be easily predicted with the level of science and technology available at the time of shipment from our company
- [4] A natural disaster, man-made disaster, incident or accident for which we are not liable
- [5] Natural fading of paint or other symptoms of aging
- [6] Wear, depletion or other expected result of use
- [7] Operation noise, vibration or other subjective sensation not affecting function or maintenance

Note that the warranty only covers our product as delivered and that any secondary loss arising from a breakdown of our product is excluded from the scope of warranty.

7.3 Honoring the Warranty

As a rule, the product must be brought to us for repair under warranty.

7.4 Limited Liability

- (1) We shall assume no liability for any special damage, consequential loss or passive loss such as a loss of expected profit arising from or in connection with our product.
- (2) We shall not be liable for any program or control method created by the customer to operate our product or for the result of such program or control method.

7.5 Conditions of Conformance with Applicable Standards/Regulations, Etc., and Applications

- (1) If our product is combined with another product or any system, device, etc., used by the customer, the customer must first check the applicable standards, regulations and/or rules. The customer is also responsible for confirming that such combination with our product conforms to the applicable standards, etc. In such a case we will not be liable for the conformance of our product with the applicable standards, etc.
- (2) Our product is for general industrial use. It is not intended or designed for the applications specified below, which require a high level of safety. Accordingly, as a rule our product cannot be used in these applications. Contact us if you must use our product for any of these applications:
 - 1) Medical equipment used to maintain, control or otherwise affect human life or physical health.
 - 2) Mechanisms and machinery designed for the purpose of moving or transporting people (For vehicle, railway facility or air navigation facility)
 - 3) Important safety parts of machinery (Safety device, etc.)
 - 4) Equipment used to handle cultural assets, art or other irreplaceable items
- (3) Contact us at the earliest opportunity if our product is to be used in any condition or environment that differs from what is specified in the catalog or instruction manual.

7.6 Other Items Excluded from Warranty

The price of the product delivered to you does not include expenses associated with programming, the dispatch of engineers, etc. Accordingly, a separate fee will be charged in the following cases even during the warranty period:

- [1] Guidance for installation/adjustment and witnessing of test operation
- [2] Maintenance and inspection
- [3] Technical guidance and education on operating/wiring methods, etc.
- [4] Technical guidance and education on programming and other items related to programs

Change History

Revision Date	Description of Revision
January 2016	First edition
April 2016	Edition 1B <ul style="list-style-type: none"> • Pg. 20 Corrected "Number of Encoder Pulse" to "800" • Pg. 23, 32 Partially corrected the payload by acceleration/deceleration • Pg. 46 Changed the description for slider spacer • Pg. 56 Added SA8 with strokes 50 and 100 as models without oblong holes • Pg. 59 Corrected A and B dimensions of 5A8R • Pg. 83 Changed belt manufacturer for SA4R, SA7R and SA8R • Pg. 104, 113, 114 Corrected "J (Ø4 hole - oblong hole)" to "J (Ø6 hole - oblong hole)"
May 2016	Edition 1C <ul style="list-style-type: none"> •Pg. 89 Added precautions about static electricity during motor replacement
Jun 2016	Second edition <ul style="list-style-type: none"> • Added contents for cleanroom type • Added contents for double slider specification (option) • Added specifications about when high-output setting is ineffective • Pg. 76 Changed graphs about duty ratio • Changed the tolerances of the oblong holes for RCP6(S)(CR)-SA6C/R, SA7C/R, SA8C/R in 5 "External Dimensions" from +0.010 to +0.012.



IAI Corporation

Head Office: 577-1 Obane Shimizu-KU Shizuoka City Shizuoka 424-0103, Japan
TEL +81-54-364-5105 FAX +81-54-364-2589
website: www.iai-robot.co.jp/

Technical Support available in USA, Europe and China

IAI America, Inc.

Head Office: 2690 W. 237th Street, Torrance, CA 90505
TEL (310) 891-6015 FAX (310) 891-0815
Chicago Office: 110 East State Parkway, Schaumburg, IL 60173
TEL (847) 908-1400 FAX (847) 908-1399
Atlanta Office: 1220 Kennestone Circle, Suite 108, Marietta, GA 30066
TEL (678) 354-9470 FAX (678) 354-9471
website: www.intelligentactuator.com

IAI Industrieroboter GmbH

Ober der Röth 4, D-65824 Schwalbach am Taunus, Germany
TEL 06196-88950 FAX 06196-889524

IAI (Shanghai) Co., Ltd.

SHANGHAI JIAHUA BUSINESS CENTER A8-303, 808, Hongqiao Rd. Shanghai 200030, China
TEL 021-6448-4753 FAX 021-6448-3992
website: www.iai-robot.com

IAI Robot (Thailand) Co., Ltd.

825, PhairojKijja Tower 12th Floor, Bangna-Trad RD., Bangna, Bangkok 10260, Thailand
TEL +66-2-361-4458 FAX +66-2-361-4456

The information contained in this document is subject to change without notice for purposes of product improvement.

Copyright © 2016. Jun. IAI Corporation. All rights reserved.