



# ROBO Cylinder RCP6/RCP6S Actuator Table Type Instruction Manual

══════════════════ **Second edition** ══════════════════

Motor Straight Type: TA4C, TA6C, TA7C  
Side-Mounted Motor Type: TA4R, TA6R, TA7R



## **Please Read Before Use**

Thank you for purchasing our product.

This instruction manual explains the handling methods, structure and maintenance of this product, among others, providing the information you need to know to use the product safely.

Before using the product, be sure to read this manual and fully understand the contents explained herein to ensure safe use of the product.

The DVD that comes with the product contains instruction manuals for IAI products.

When using the product, refer to the necessary portions of the applicable instruction manual by printing them out or displaying them on a PC.

After reading the instruction manual, keep it in a convenient place so that whoever is handling this product can reference it quickly when necessary.

### **[Important]**

- This instruction manual is original.
- This product is not to be used for any other purpose from what is noted in this instruction manual. IAI shall not be liable whatsoever for any loss or damage arising from the result of using the product for any other purpose from what is noted in the manual.
- The information contained in this instruction manual is subject to change without notice for the purpose of production improvement.
- If you have any question or finding regarding the information contained in this instruction manual, contact our customer center or our sales office near you.
- Using or copying all or a part of this instruction manual without permission is prohibited.
- The company names, names of products and trademarks of each company shown in the sentences are registered trademarks.

**RC** ROBO  
CYLINDER

---

---

## Table of Contents

|   |     |
|---|-----|
| Safety Guide .....  | 1   |
| Caution in Handling .....   | 9   |
| International Standards Compliances .....   | 10  |
| Names of the Parts .....  | 11  |
| 1. Specifications Check .....   | 13  |
| 1.1 Checking the Product .....  | 13  |
| 1.1.1 Parts.....  | 13  |
| 1.1.2 Related Instruction Manuals for the Each Controller Supported by This Product | 13  |
| 1.1.3 How to Read the Model Nameplate.....  | 13  |
| 1.1.4 How to Read the Model Number .....  | 14  |
| 1.2 Specifications .....  | 15  |
| 1.2.1 Speed.....  | 15  |
| 1.2.2 Maximum Acceleration and Transportable Mass.....                              | 23  |
| 1.2.3 Allowable Transportable Mass.....   | 67  |
| 1.2.4 Driving System • Position Detector.....                                       | 73  |
| 1.2.5 Positioning Precision .....   | 74  |
| 1.2.6 Current Limit Value and Pressing Force.....                                   | 75  |
| 1.2.7 Allowable Moment of Actuator .....  | 78  |
| 1.2.8 Moment Load Displacement Amount.....  | 80  |
| 1.2.9 Duty Ratio for Continuous Operation.....                                      | 83  |
| 1.3 Options .....   | 84  |
| 1.3.1 Brake Type (Model : B).....   | 84  |
| 1.3.2 Reversed-home Specification (Model : NM).....                                 | 84  |
| 1.3.3 Motor Left Side-Mounted, Motor Right Side-Mounted (Model: ML, MR).....        | 84  |
| 1.3.4 Cable Exit Direction Changed (Model: CJT, CJR, CJL, CJB, CJO) .....           | 85  |
| 1.3.5 High Rigidity Specification (Double Guide Block) (Model: DB) .....            | 85  |
| 1.4 Motor • Encoder Cables.....   | 86  |
| 1.4.1 Motor • Encoder Integrated Cables .....                                       | 86  |
| 1.4.2 Motor • Encoder Integrated Cables Robot Type.....                             | 87  |
| 2. Installation .....   | 88  |
| 2.1 Transportation.....   | 88  |
| 2.2 Installation and Storage • Preservation Environment .....                       | 90  |
| 2.3 How to Install .....  | 91  |
| 2.3.1 Installation.....   | 91  |
| 2.3.2 Installation of the Main Unit .....   | 92  |
| 3. Connecting with the Controller .....   | 101 |
| 4. Maintenance and Inspection .....   | 105 |
| 4.1 Inspection Items and Schedule.....  | 105 |
| 4.2 External Visual Inspection.....   | 106 |
| 4.3 Cleaning .....  | 106 |
| 4.4 Internal Inspections .....  | 107 |
| 4.5 Internal Cleaning .....   | 108 |
| 4.6 Grease Supply.....  | 109 |
| 4.6.1 Standard Type Grease to Use .....   | 109 |
| 4.6.2 How to Apply Grease.....  | 109 |
| 4.7 Procedure for Belt Replacement and Tuning .....                                 | 110 |
| 4.7.1 Inspection of the Belt .....  | 110 |
| 4.7.2 Belt to Use .....   | 110 |
| 4.7.3 Belt Replacement .....  | 111 |
| 4.8 Motor Replacement Process.....  | 115 |

|       |   |     |
|-------|---|-----|
| 4.8.1 | TA4C, TA6C, TA7C .....  | 115 |
| 4.8.2 | TA4R, TA6R, TA7R .....  | 117 |
| 5.    | External Dimensions .....   | 124 |
| 5.1   | Standard Specification RCP6-TA4C .....  | 124 |
| 5.2   | Built-in Controller Specification RCP6S-TA4C.....   | 125 |
| 5.3   | Standard Specification RCP6-TA6C .....  | 126 |
| 5.4   | Built-in Controller Specification RCP6S-TA6C.....   | 127 |
| 5.5   | Standard Specification RCP6-TA7C .....  | 128 |
| 5.6   | Built-in Controller Specification RCP6S-TA7C.....   | 129 |
| 5.7   | Standard Specification RCP6-TA4R Left Side-Mounted (Model: ML) .....                          | 130 |
| 5.8   | Built-in Controller Specification RCP6S-TA4R Left Side-Mounted (Model: ML)                    | 131 |
| 5.9   | Standard Specification RCP6-TA6R Left Side-Mounted (Model: ML) .....                          | 132 |
| 5.10  | Built-in Controller Specification RCP6S-TA6R Left Side-Mounted (Model: ML)                    | 133 |
| 5.11  | Standard Specification RCP6-TA7R Left Side-Mounted (Model: ML) .....                          | 134 |
| 5.12  | Built-in Controller Specification RCP6S-TA7R Left Side-Mounted (Model: ML)                    | 135 |
| 6.    | Life .....  | 136 |
| 7.    | Warranty.....   | 137 |
| 7.1   | Warranty Period.....  | 137 |
| 7.2   | Scope of the Warranty .....   | 137 |
| 7.3   | Honoring the Warranty.....  | 137 |
| 7.4   | Limited Liability .....   | 138 |
| 7.5   | Conditions of Conformance with Applicable Standards/Regulations, Etc., and Applications ..... | 138 |
| 7.6   | Other Items Excluded from Warranty .....  | 138 |
|       | Change History.....   | 139 |

## Safety Guide

“Safety Guide” has been written to use the machine safely and so prevent personal injury or property damage beforehand. Make sure to read it before the operation of this product.

### Safety Precautions for Our Products

The common safety precautions for the use of any of our robots in each operation.

| No. | Operation Description | Description  |
|-----|-----------------------|--|
| 1   | Model Selection       | <ul style="list-style-type: none"> <li>• This product has not been planned and designed for the application where high level of safety is required, so the guarantee of the protection of human life is impossible. Accordingly, do not use it in any of the following applications.               <ol style="list-style-type: none"> <li>1) Medical equipment used to maintain, control or otherwise affect human life or physical health.</li> <li>2) Mechanisms and machinery designed for the purpose of moving or transporting people (For vehicle, railway facility or air navigation facility)</li> <li>3) Important safety parts of machinery (Safety device, etc.)</li> </ol> </li> <li>• Do not use the product outside the specifications. Failure to do so may considerably shorten the life of the product.</li> <li>• Do not use it in any of the following environments.               <ol style="list-style-type: none"> <li>1) Location where there is any inflammable gas, inflammable object or explosive</li> <li>2) Place with potential exposure to radiation</li> <li>3) Location with the ambient temperature or relative humidity exceeding the specification range</li> <li>4) Location where radiant heat is added from direct sunlight or other large heat source</li> <li>5) Location where condensation occurs due to abrupt temperature changes</li> <li>6) Location where there is any corrosive gas (sulfuric acid or hydrochloric acid)</li> <li>7) Location exposed to significant amount of dust, salt or iron powder</li> <li>8) Location subject to direct vibration or impact</li> </ol> </li> <li>• For an actuator used in vertical orientation, select a model which is equipped with a brake. If selecting a model with no brake, the moving part may drop when the power is turned OFF and may cause an accident such as an injury or damage on the work piece.</li> </ul> |

| No. | Operation Description    | Description   |
|-----|--------------------------|---|
| 2   | Transportation           | <ul style="list-style-type: none"> <li>● When carrying a heavy object, do the work with two or more persons or utilize equipment such as crane.</li> <li>● When the work is carried out with 2 or more persons, make it clear who is to be the leader and who to be the follower(s) and communicate well with each other to ensure the safety of the workers.</li> <li>● When in transportation, consider well about the positions to hold, weight and weight balance and pay special attention to the carried object so it would not get hit or dropped.</li> <li>● Transport it using an appropriate transportation measure.<br/>The actuators available for transportation with a crane have eyebolts attached or there are tapped holes to attach bolts. Follow the instructions in the instruction manual for each model.</li> <li>● Do not step or sit on the package.</li> <li>● Do not put any heavy thing that can deform the package, on it.</li> <li>● When using a crane capable of 1t or more of weight, have an operator who has qualifications for crane operation and sling work.</li> <li>● When using a crane or equivalent equipments, make sure not to hang a load that weighs more than the equipment's capability limit.</li> <li>● Use a hook that is suitable for the load. Consider the safety factor of the hook in such factors as shear strength.</li> <li>● Do not get on the load that is hung on a crane.</li> <li>● Do not leave a load hung up with a crane.</li> <li>● Do not stand under the load that is hung up with a crane.</li> </ul> |
| 3   | Storage and Preservation | <ul style="list-style-type: none"> <li>● The storage and preservation environment conforms to the installation environment. However, especially give consideration to the prevention of condensation.</li> <li>● Store the products with a consideration not to fall them over or drop due to an act of God such as earthquake.</li> </ul>  |

| No. | Operation Description  | Description  |
|-----|------------------------|--|
| 4   | Installation and Start | <p>(1) Installation of Robot Main Body and Controller, etc.</p> <ul style="list-style-type: none"> <li>● Make sure to securely hold and fix the product (including the work part). A fall, drop or abnormal motion of the product may cause a damage or injury.<br/>Also, be equipped for a fall-over or drop due to an act of God such as earthquake.</li> <li>● Do not get on or put anything on the product. Failure to do so may cause an accidental fall, injury or damage to the product due to a drop of anything, malfunction of the product, performance degradation, or shortening of its life.</li> <li>● When using the product in any of the places specified below, provide a sufficient shield.               <ol style="list-style-type: none"> <li>1) Location where electric noise is generated</li> <li>2) Location where high electrical or magnetic field is present</li> <li>3) Location with the mains or power lines passing nearby</li> <li>4) Location where the product may come in contact with water, oil or chemical droplets</li> </ol> </li> </ul> <p>(2) Cable Wiring</p> <ul style="list-style-type: none"> <li>● Use our company's genuine cables for connecting between the actuator and controller, and for the teaching tool.</li> <li>● Do not scratch on the cable. Do not bend it forcibly. Do not pull it. Do not coil it around. Do not insert it. Do not put any heavy thing on it. Failure to do so may cause a fire, electric shock or malfunction due to leakage or continuity error.</li> <li>● Perform the wiring for the product, after turning OFF the power to the unit, so that there is no wiring error.</li> <li>● When the direct current power (+24V) is connected, take the great care of the directions of positive and negative poles.<br/>If the connection direction is not correct, it might cause a fire, product breakdown or malfunction.</li> <li>● Connect the cable connector securely so that there is no disconnection or looseness. Failure to do so may cause a fire, electric shock or malfunction of the product.</li> <li>● Never cut and/or reconnect the cables supplied with the product for the purpose of extending or shortening the cable length. Failure to do so may cause the product to malfunction or cause fire.</li> </ul> <p>(3) Grounding</p> <ul style="list-style-type: none"> <li>● The grounding operation should be performed to prevent an electric shock or electrostatic charge, enhance the noise-resistance ability and control the unnecessary electromagnetic radiation.</li> <li>● For the ground terminal on the AC power cable of the controller and the grounding plate in the control panel, make sure to use a twisted pair cable with wire thickness 0.5mm<sup>2</sup> (AWG20 or equivalent) or more for grounding work. For security grounding, it is necessary to select an appropriate wire thickness suitable for the load. Perform wiring that satisfies the specifications (electrical equipment technical standards).</li> <li>● Perform Class D Grounding (former Class 3 Grounding with ground resistance 100Ω or below).</li> </ul> |

| No. | Operation Description  | Description  |
|-----|------------------------|--|
| 4   | Installation and Start | <p>(4) Safety Measures</p> <ul style="list-style-type: none"> <li>● When the work is carried out with 2 or more persons, make it clear who is to be the leader and who to be the follower(s) and communicate well with each other to ensure the safety of the workers.</li> <li>● When the product is under operation or in the ready mode, take the safety measures (such as the installation of safety and protection fence) so that nobody can enter the area within the robot's movable range. When the robot under operation is touched, it may result in death or serious injury.</li> <li>● Make sure to install the emergency stop circuit so that the unit can be stopped immediately in an emergency during the unit operation.</li> <li>● Take the safety measure not to start up the unit only with the power turning ON. Failure to do so may start up the machine suddenly and cause an injury or damage to the product.</li> <li>● Take the safety measure not to start up the machine only with the emergency stop cancellation or recovery after the power failure. Failure to do so may result in an electric shock or injury due to unexpected power input.</li> <li>● When the installation or adjustment operation is to be performed, give clear warnings such as "Under Operation; Do not turn ON the power!" etc. Sudden power input may cause an electric shock or injury.</li> <li>● Take the measure so that the work part is not dropped in power failure or emergency stop.</li> <li>● Wear protection gloves, goggle or safety shoes, as necessary, to secure safety.</li> <li>● Do not insert a finger or object in the openings in the product. Failure to do so may cause an injury, electric shock, damage to the product or fire.</li> <li>● When releasing the brake on a vertically oriented actuator, exercise precaution not to pinch your hand or damage the work parts with the actuator dropped by gravity.</li> </ul> |





| No. | Operation Description | Description  |
|-----|-----------------------|--|
| 5   | Teaching              | <ul style="list-style-type: none"> <li>● When the work is carried out with 2 or more persons, make it clear who is to be the leader and who to be the follower(s) and communicate well with each other to ensure the safety of the workers.</li> <li>● Perform the teaching operation from outside the safety protection fence, if possible. In the case that the operation is to be performed unavoidably inside the safety protection fence, prepare the “Stipulations for the Operation” and make sure that all the workers acknowledge and understand them well.</li> <li>● When the operation is to be performed inside the safety protection fence, the worker should have an emergency stop switch at hand with him so that the unit can be stopped any time in an emergency.</li> <li>● When the operation is to be performed inside the safety protection fence, in addition to the workers, arrange a watchman so that the machine can be stopped any time in an emergency. Also, keep watch on the operation so that any third person can not operate the switches carelessly.</li> <li>● Place a sign “Under Operation” at the position easy to see.</li> <li>● When releasing the brake on a vertically oriented actuator, exercise precaution not to pinch your hand or damage the work parts with the actuator dropped by gravity.</li> </ul> <p>* Safety protection Fence : In the case that there is no safety protection fence, the movable range should be indicated.</p> |
| 6   | Trial Operation       | <ul style="list-style-type: none"> <li>● When the work is carried out with 2 or more persons, make it clear who is to be the leader and who to be the follower(s) and communicate well with each other to ensure the safety of the workers.</li> <li>● After the teaching or programming operation, perform the check operation one step by one step and then shift to the automatic operation.</li> <li>● When the check operation is to be performed inside the safety protection fence, perform the check operation using the previously specified work procedure like the teaching operation.</li> <li>● Make sure to perform the programmed operation check at the safety speed. Failure to do so may result in an accident due to unexpected motion caused by a program error, etc.</li> <li>● Do not touch the terminal block or any of the various setting switches in the power ON mode. Failure to do so may result in an electric shock or malfunction.</li> </ul>  |

| No. | Operation Description      | Description   |
|-----|----------------------------|---|
| 7   | Automatic Operation        | <ul style="list-style-type: none"> <li>● Check before starting the automatic operation or rebooting after operation stop that there is nobody in the safety protection fence.</li> <li>● Before starting automatic operation, make sure that all peripheral equipment is in an automatic-operation-ready state and there is no alarm indication.</li> <li>● Make sure to operate automatic operation start from outside of the safety protection fence.</li> <li>● In the case that there is any abnormal heating, smoke, offensive smell, or abnormal noise in the product, immediately stop the machine and turn OFF the power switch. Failure to do so may result in a fire or damage to the product.</li> <li>● When a power failure occurs, turn OFF the power switch. Failure to do so may cause an injury or damage to the product, due to a sudden motion of the product in the recovery operation from the power failure.</li> </ul>   |
| 8   | Maintenance and Inspection | <ul style="list-style-type: none"> <li>● When the work is carried out with 2 or more persons, make it clear who is to be the leader and who to be the follower(s) and communicate well with each other to ensure the safety of the workers.</li> <li>● Perform the work out of the safety protection fence, if possible. In the case that the operation is to be performed unavoidably inside the safety protection fence, prepare the “Stipulations for the Operation” and make sure that all the workers acknowledge and understand them well.</li> <li>● When the work is to be performed inside the safety protection fence, basically turn OFF the power switch.</li> <li>● When the operation is to be performed inside the safety protection fence, the worker should have an emergency stop switch at hand with him so that the unit can be stopped any time in an emergency.</li> <li>● When the operation is to be performed inside the safety protection fence, in addition to the workers, arrange a watchman so that the machine can be stopped any time in an emergency. Also, keep watch on the operation so that any third person can not operate the switches carelessly.</li> <li>● Place a sign “Under Operation” at the position easy to see.</li> <li>● For the grease for the guide or ball screw, use appropriate grease according to the instruction manual for each model.</li> <li>● Do not perform the dielectric strength test. Failure to do so may result in a damage to the product.</li> <li>● When releasing the brake on a vertically oriented actuator, exercise precaution not to pinch your hand or damage the work parts with the actuator dropped by gravity.</li> <li>● The slider or rod may get misaligned OFF the stop position if the servo is turned OFF. Be careful not to get injured or damaged due to an unnecessary operation.</li> <li>● Pay attention not to lose the cover or untightened screws, and make sure to put the product back to the original condition after maintenance and inspection works.<br/>Use in incomplete condition may cause damage to the product or an injury.</li> </ul> <p>* Safety protection Fence : In the case that there is no safety protection fence, the movable range should be indicated.</p> |

| No. | Operation Description      | Description  |
|-----|----------------------------|--|
| 9   | Modification and Dismantle | <ul style="list-style-type: none"><li>• Do not modify, disassemble, assemble or use of maintenance parts not specified based at your own discretion.</li></ul>   |
| 10  | Disposal                   | <ul style="list-style-type: none"><li>• When the product becomes no longer usable or necessary, dispose of it properly as an industrial waste.</li><li>• When removing the actuator for disposal, pay attention to drop of components when detaching screws.</li><li>• Do not put the product in a fire when disposing of it. The product may burst or generate toxic gases.</li></ul>   |
| 11  | Other                      | <ul style="list-style-type: none"><li>• Do not come close to the product or the harnesses if you are a person who requires a support of medical devices such as a pacemaker. Doing so may affect the performance of your medical device.</li><li>• See Overseas Specifications Compliance Manual to check whether complies if necessary.</li><li>• For the handling of actuators and controllers, follow the dedicated instruction manual of each unit to ensure the safety.</li></ul> |

## Alert Indication

The safety precautions are divided into “Danger”, “Warning”, “Caution” and “Notice” according to the warning level, as follows, and described in the instruction manual for each model.

| Level   | Degree of Danger and Damage   | Symbol  |
|---------|---|---|
| Danger  | This indicates an imminently hazardous situation which, if the product is not handled correctly, will result in death or serious injury.        |  Danger  |
| Warning | This indicates a potentially hazardous situation which, if the product is not handled correctly, could result in death or serious injury.       |  Warning |
| Caution | This indicates a potentially hazardous situation which, if the product is not handled correctly, may result in minor injury or property damage. |  Caution |
| Notice  | This indicates lower possibility for the injury, but should be kept to use this product properly.   |  Notice  |

## Caution in Handling

---

1. Do not attempt to establish the settings for the speed and acceleration/deceleration above the allowable range.

An operation with speed and acceleration/deceleration beyond the allowable range may cause an abnormal noise, vibration, malfunction or shortened life.
2. Set the allowable load moment within the allowable range.

An operation with the load beyond the allowable load moment may cause an abnormal noise, vibration, malfunction or shortened life. If it is extreme, flaking may occur on the guide, ball screw.
3. Set the overhang within the allowable range.

Attaching a load with an overhang above the allowable range may cause vibration and abnormal noise.
4. If back and forth operations are performed repeatedly in short distance, it may wear out the film of grease.

Continuous back and forth operation within a distance less than 30mm may cause wear of grease. As a reference, have approximately 5 cycles of back and forth operation in a distance more than 50mm in every 5,000 to 10,000 cycles to regenerate the oil film. Keep using the actuator with the grease worn out may cause malfunction. If it is extreme, flaking may occur on the guide, ball screw.
5. Do not attempt to hit the table against an abstacle with high speed.

It may destroy the coupling.
6. Make sure to attach the actuator properly by following this instruction manual.

Using the product with the actuator not being certainly retained or affixed may cause abnormal noise, vibration, malfunction or shorten the product life.
7. Make sure to follow the usage condition, environment and specification range of the product.

In case it is not secured, it may cause a drop in performance or malfunction of the product.

8. For PCON-CB and MCON Controllers (with option: T), it is available to switch over the setting between effective and ineffective of the high-output setting in the parameter setting.

(In the setting at delivery, the high output setting is set to effective.)

For MSEL Controller, the high output setting is effective and cannot switch it over to ineffective.  
[Refer to an instruction manual for each controller for details]

The performance of weight capacity at each velocity and acceleration/deceleration setting differs between the high output setting being effective and ineffective. Refer to the applicable performance specification when the high-output setting is effective or ineffective in 1.2 Specifications.

| Controller | Parameter  | Remarks  |
|------------|--|--|
| PCON-CB    | No.152 High Output Setting<br>[0: Ineffective, 1: Effective] |  |
| MCON       | No.152 High Output Setting<br>[0: Ineffective, 1: Effective] | Option T: In high output setting, available to have high output setting effective. |

## International Standards Compliances

This actuator complies with the following overseas standard.

Refer to Overseas Standard Compliance Manual (ME0287) for more detailed information.

| RoHS Directive | CE Marking |
|----------------|------------|
| ○              | ○          |

## Names of the Parts

In this Instruction manual, the left and right sides are indicated by looking at the actuator from the motor end, with the actuator placed horizontally, as shown in the figure below.

### 1. Motor Straight Type

#### 1.1 Standard Specification

RCP6-TA4C, TA6C, TA7C

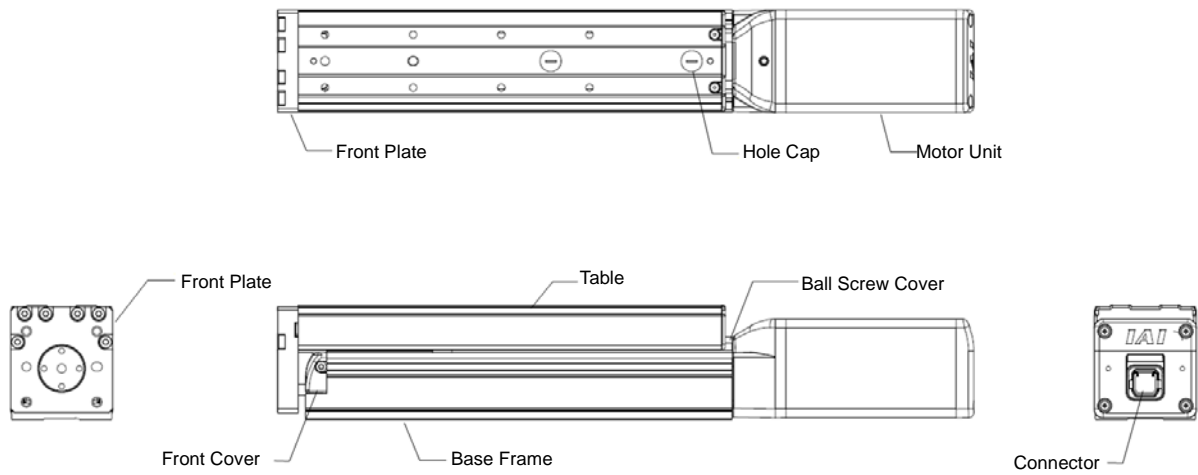

#### 1.2 Built-in Controller Specification RCP6S-TA4C, TA6C, TA7C

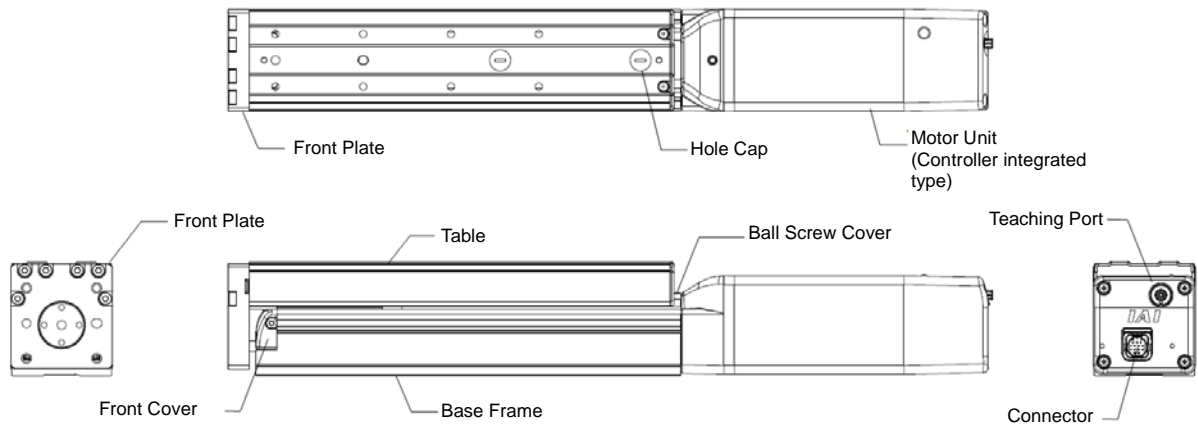

2. Side-Mounted Motor Type

2.1 Standard Specification

RCP6-TA4R, TA6R, TA7R

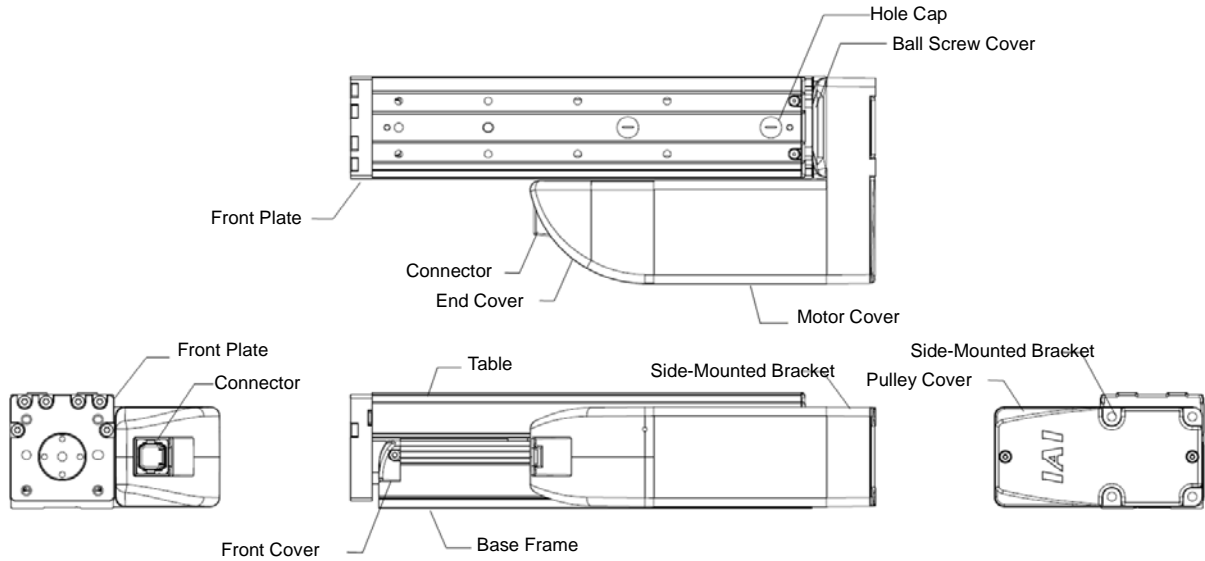

2.2 Built-in Controller Specification RCP6S-TA4R, TA6R, TA7R

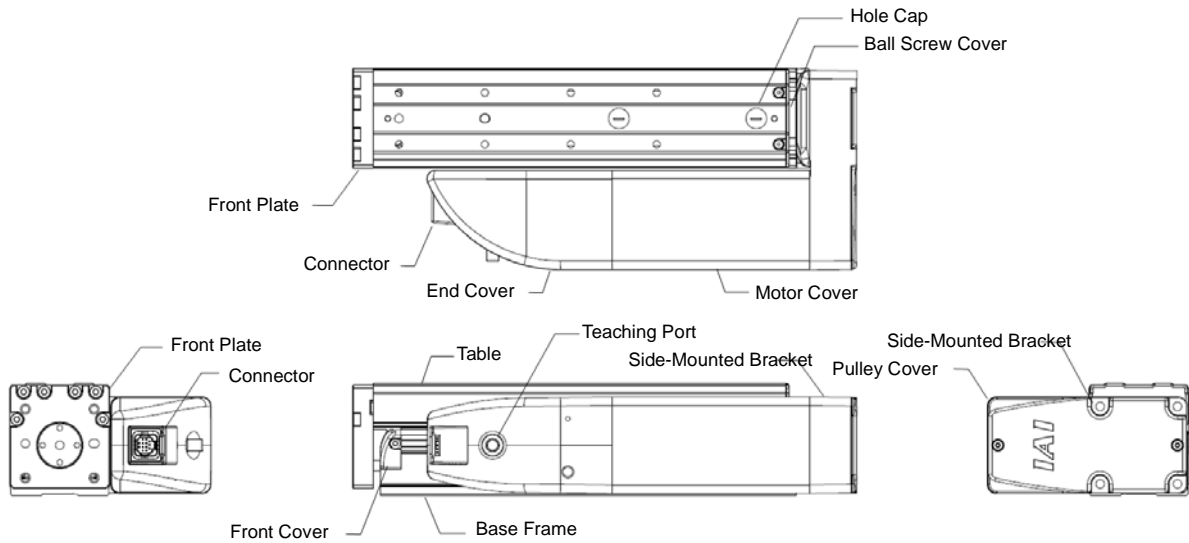

The direction of the motor is either left side-mounted: ML (shown in figure above), right side-mounted: MR.

## 1. Specifications Check

### 1.1 Checking the Product

The standard configuration of this product is comprised of the following parts. See the component list for the details of the enclosed components. If you find any fault or missing parts, contact your local IAI distributor.

#### 1.1.1 Parts

| No.         | Name                                      | Model number   | Quantity | Remarks |
|-------------|---|--|----------|---------|
| 1           | Actuator                                  | Refer to "How to Read the Model Nameplate" and "How to Read the Model Number." | 1        |         |
| Accessories |   |  |          |         |
| 2           | Motor • Encoder Cables <sup>(Note1)</sup> |  | 1        |         |
| 3           | In-house Made Seals                       |  | 1        |         |
| 4           | First Step Guide                          |  | 1        |         |
| 5           | Instruction Manual (DVD)                  |  | 1        |         |
| 6           | Safety Guide                              |  | 1        |         |

Note 1 The motor • encoder cables supplied vary depending on the controller used. [Refer to 1.4, "Motor • Encoder Cables."]

#### 1.1.2 Related Instruction Manuals for the Each Controller Supported by This Product

Shown below is a list of the instruction manuals for the controllers related to this product which is recorded in Instruction Manual (DVD).

| No. | Name  | Control No. |
|-----|---|-------------|
| 1   | Instruction Manual for PCON-CB/CFB Controller   | ME0342      |
| 2   | Instruction Manual for MCON-C/CG Controller   | ME0341      |
| 3   | Instruction Manual for MSEL Controller  | ME0336      |
| 4   | Instruction Manual for RC PC Software<br>RCM-101-MW/RCM-101-USB   | ME0155      |
| 5   | Instruction Manual for Touch Panel Teaching Pendant<br>CON-PTA/PDA/PGA                                      | ME0295      |
| 6   | Instruction Manual for Touch Panel Teaching Pendant<br>TB-01/01D/01DR<br>Applicable for Position Controller | ME0324      |

#### 1.1.3 How to Read the Model Nameplate

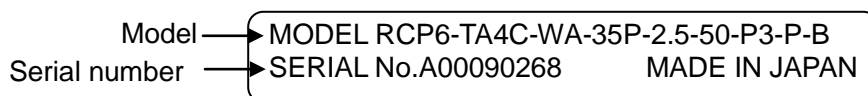

## 1.1.4 How to Read the Model Number

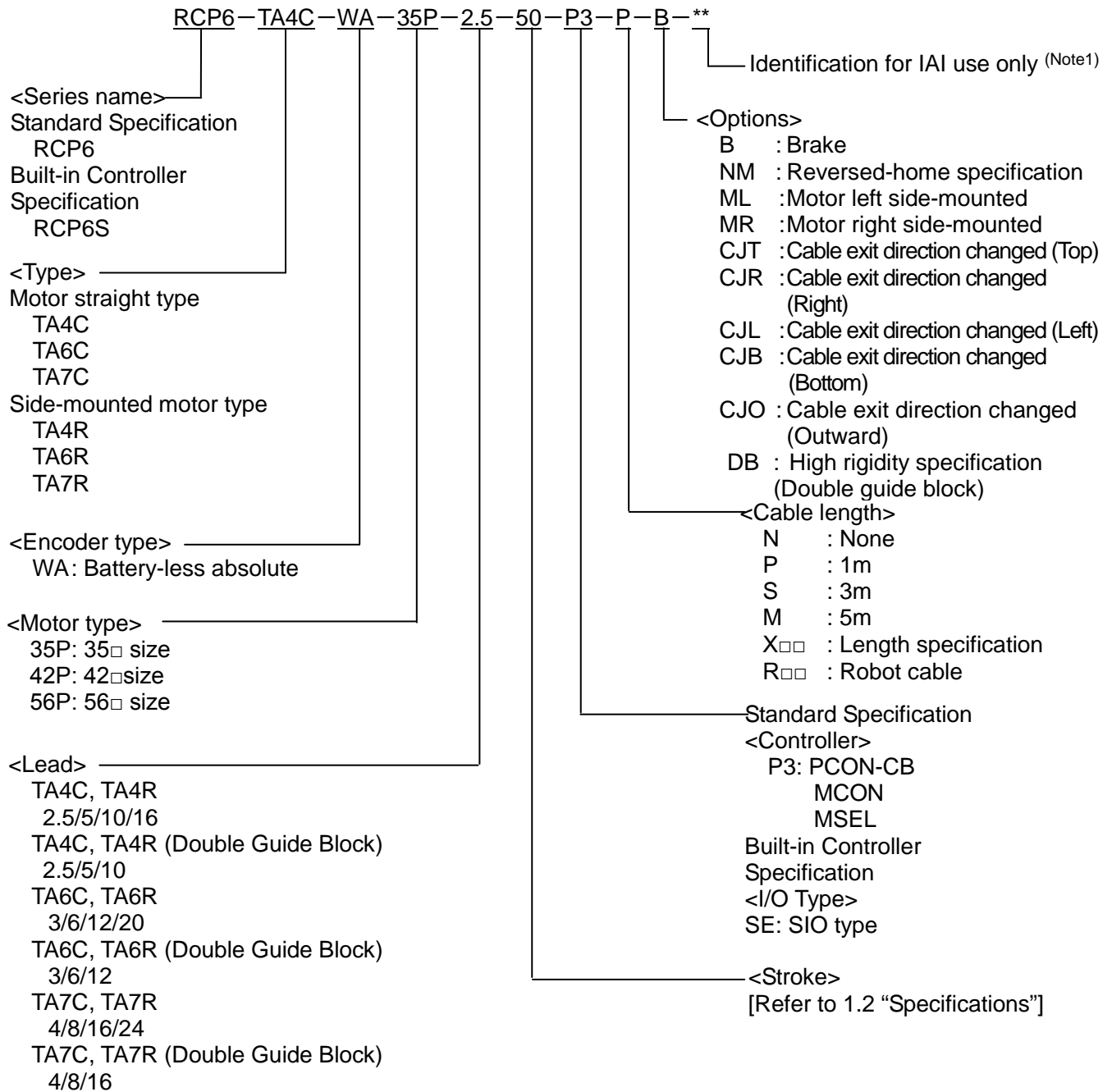

Note 1 Identification for IAI use only: It may be displayed for IAI use. It is not a code to show the model type.

## 1.2 Specifications

### 1.2.1 Speed

[When high-output setting for motor straight type is effective]

- Standard Specification

Speed limits [Unit: mm/s]

| Type | Motor Type | Lead [mm] | Horizontal/<br>Vertical | Stroke [mm] |    |    |     |     |     |     |     |     |     |
|------|------------|-----------|-------------------------|-------------|----|----|-----|-----|-----|-----|-----|-----|-----|
|      |            |           |                         | 25          | 50 | 75 | 100 | 125 | 150 | -   | -   | -   | -   |
| TA4C | 35P        | 2.5       | Horizontal              | 195         |    |    |     | -   | -   | -   | -   |     |     |
|      |            |           | Vertical                | 195         |    |    |     | -   | -   | -   | -   |     |     |
|      |            | 5         | Horizontal              | 390         |    |    |     | -   | -   | -   | -   |     |     |
|      |            |           | Vertical                | 390         |    |    |     | -   | -   | -   | -   |     |     |
|      |            | 10        | Horizontal              | 785         |    |    |     | -   | -   | -   | -   |     |     |
|      |            |           | Vertical                | 700         |    |    |     | -   | -   | -   | -   |     |     |
|      |            | 16        | Horizontal              | 980         |    |    |     | -   | -   | -   | -   |     |     |
|      |            |           | Vertical                | 700         |    |    |     | -   | -   | -   | -   |     |     |
|      |            |           |                         | 25          | 50 | 75 | 100 | 125 | 150 | 175 | 200 | -   | -   |
| TA6C | 42P        | 3         | Horizontal              | 200         |    |    |     | -   | -   | -   | -   |     |     |
|      |            |           | Vertical                | 200         |    |    |     | -   | -   | -   | -   |     |     |
|      |            | 6         | Horizontal              | 400         |    |    |     | -   | -   | -   | -   |     |     |
|      |            |           | Vertical                | 400         |    |    |     | -   | -   | -   | -   |     |     |
|      |            | 12        | Horizontal              | 800         |    |    |     | -   | -   | -   | -   |     |     |
|      |            |           | Vertical                | 800         |    |    |     | -   | -   | -   | -   |     |     |
|      |            | 20        | Horizontal              | 1120        |    |    |     | -   | -   | -   | -   |     |     |
|      |            |           | Vertical                | 800         |    |    |     | -   | -   | -   | -   |     |     |
|      |            |           |                         | 25          | 50 | 75 | 100 | 125 | 150 | 175 | 200 | 250 | 300 |
| TA7C | 56P        | 4         | Horizontal              | 210         |    |    |     | -   | -   | -   | -   |     |     |
|      |            |           | Vertical                | 210         |    |    |     | -   | -   | -   | -   |     |     |
|      |            | 8         | Horizontal              | 420         |    |    |     | -   | -   | -   | -   |     |     |
|      |            |           | Vertical                | 350         |    |    |     | -   | -   | -   | -   |     |     |
|      |            | 16        | Horizontal              | 700         |    |    |     | -   | -   | -   | -   |     |     |
|      |            |           | Vertical                | 560         |    |    |     | -   | -   | -   | -   |     |     |
|      |            | 24        | Horizontal              | 1080        |    |    |     | -   | -   | -   | -   |     |     |
|      |            |           | Vertical                | 860         |    |    |     | -   | -   | -   | -   |     |     |

[When high-output setting for motor straight type is effective]

- Double Guide Block (Option Model: DB)

Speed limits [Unit: mm/s]

| Type | Motor Type | Lead [mm] | Horizontal/<br>Vertical | Stroke [mm] |    |    |     |     |     |     |     |     |
|------|------------|-----------|-------------------------|-------------|----|----|-----|-----|-----|-----|-----|-----|
|      |            |           |                         | 40          | 65 | 90 | 140 | 190 | 240 | -   | -   | -   |
| TA4C | 35P        | 2.5       | Horizontal              | 195         |    |    |     |     | 170 | -   | -   | -   |
|      |            |           | Vertical                | 195         |    |    |     |     | 170 | -   | -   | -   |
|      |            | 5         | Horizontal              | 390         |    |    |     |     | 340 | -   | -   | -   |
|      |            |           | Vertical                | 390         |    |    |     |     | 340 | -   | -   | -   |
|      |            | 10        | Horizontal              | 785         |    |    |     |     | 680 | -   | -   | -   |
|      |            |           | Vertical                | 700         |    |    |     |     | 680 | -   | -   | -   |
|      |            |           |                         | 45          | 70 | 95 | 120 | 170 | 220 | 270 | 320 | -   |
| TA6C | 42P        | 3         | Horizontal              | 200         |    |    |     |     | 185 | 140 | -   |     |
|      |            |           | Vertical                | 200         |    |    |     |     | 185 | 140 | -   |     |
|      |            | 6         | Horizontal              | 400         |    |    |     |     | 365 | 285 | -   |     |
|      |            |           | Vertical                | 400         |    |    |     |     | 365 | 285 | -   |     |
|      |            | 12        | Horizontal              | 800         |    |    |     |     | 735 | 575 | -   |     |
|      |            |           | Vertical                | 680         |    |    |     |     | 575 | -   | -   |     |
|      |            |           |                         | 40          | 65 | 90 | 140 | 190 | 240 | 290 | 340 | 390 |
| TA7C | 56P        | 4         | Horizontal              | 210         |    |    |     |     | 180 | 150 |     |     |
|      |            |           | Vertical                | 210         |    |    |     |     | 180 | 150 |     |     |
|      |            | 8         | Horizontal              | 420         |    |    |     |     | 365 | 300 |     |     |
|      |            |           | Vertical                | 350         |    |    |     |     | 300 | -   |     |     |
|      |            | 16        | Horizontal              | 700         |    |    |     |     | 600 | -   |     |     |
|      |            |           | Vertical                | 560         |    |    |     |     | -   | -   |     |     |

[When high-output setting for side-mounted motor type is effective]

• Standard Specification

Speed limits [Unit: mm/s]

| Type | Motor Type | Lead [mm] | Horizontal/<br>Vertical | Stroke [mm] |    |    |     |     |     |     |     |     |     |
|------|------------|-----------|-------------------------|-------------|----|----|-----|-----|-----|-----|-----|-----|-----|
|      |            |           |                         | 25          | 50 | 75 | 100 | 125 | 150 | -   | -   | -   | -   |
| TA4R | 35P        | 2.5       | Horizontal              | 195         |    |    |     |     |     | -   | -   | -   | -   |
|      |            |           | Vertical                | 195         |    |    |     |     |     | -   | -   | -   | -   |
|      |            | 5         | Horizontal              | 390         |    |    |     |     |     | -   | -   | -   | -   |
|      |            |           | Vertical                | 390         |    |    |     |     |     | -   | -   | -   | -   |
|      |            | 10        | Horizontal              | 785         |    |    |     |     |     | -   | -   | -   | -   |
|      |            |           | Vertical                | 700         |    |    |     |     |     | -   | -   | -   | -   |
|      |            | 16        | Horizontal              | 980         |    |    |     |     |     | -   | -   | -   | -   |
|      |            |           | Vertical                | 700         |    |    |     |     |     | -   | -   | -   | -   |
|      |            |           |                         | 25          | 50 | 75 | 100 | 125 | 150 | 175 | 200 | -   | -   |
| TA6R | 42P        | 3         | Horizontal              | 200         |    |    |     |     |     | -   | -   | -   | -   |
|      |            |           | Vertical                | 200         |    |    |     |     |     | -   | -   | -   | -   |
|      |            | 6         | Horizontal              | 400         |    |    |     |     |     | -   | -   | -   | -   |
|      |            |           | Vertical                | 400         |    |    |     |     |     | -   | -   | -   | -   |
|      |            | 12        | Horizontal              | 800         |    |    |     |     |     | -   | -   | -   | -   |
|      |            |           | Vertical                | 680         |    |    |     |     |     | -   | -   | -   | -   |
|      |            | 20        | Horizontal              | 1120        |    |    |     |     |     | -   | -   | -   | -   |
|      |            |           | Vertical                | 800         |    |    |     |     |     | -   | -   | -   | -   |
|      |            |           |                         | 25          | 50 | 75 | 100 | 125 | 150 | 175 | 200 | 250 | 300 |
| TA7R | 56P        | 4         | Horizontal              | 210         |    |    |     |     |     | -   | -   | -   | -   |
|      |            |           | Vertical                | 210         |    |    |     |     |     | -   | -   | -   | -   |
|      |            | 8         | Horizontal              | 420         |    |    |     |     |     | -   | -   | -   | -   |
|      |            |           | Vertical                | 350         |    |    |     |     |     | -   | -   | -   | -   |
|      |            | 16        | Horizontal              | 700         |    |    |     |     |     | -   | -   | -   | -   |
|      |            |           | Vertical                | 560         |    |    |     |     |     | -   | -   | -   | -   |
|      |            | 24        | Horizontal              | 1080        |    |    |     |     |     | -   | -   | -   | -   |
|      |            |           | Vertical                | 860         |    |    |     |     |     | -   | -   | -   | -   |

[When high-output setting for side-mounted motor type is effective]

- Double Guide Block (Option Model: DB)

Speed limits [Unit: mm/s]

| Type | Motor Type | Lead [mm] | Horizontal/<br>Vertical | Stroke [mm] |    |    |     |     |     |     |     |     |
|------|------------|-----------|-------------------------|-------------|----|----|-----|-----|-----|-----|-----|-----|
|      |            |           |                         | 40          | 65 | 90 | 140 | 190 | 240 | -   | -   | -   |
| TA4R | 35P        | 2.5       | Horizontal              | 195         |    |    |     |     | 170 | -   | -   | -   |
|      |            |           | Vertical                | 195         |    |    |     |     | 170 | -   | -   | -   |
|      |            | 5         | Horizontal              | 390         |    |    |     |     | 340 | -   | -   | -   |
|      |            |           | Vertical                | 390         |    |    |     |     | 340 | -   | -   | -   |
|      |            | 10        | Horizontal              | 700         |    |    |     |     | 680 | -   | -   | -   |
|      |            |           | Vertical                | 525         |    |    |     |     |     | -   | -   | -   |
|      |            |           |                         | 45          | 70 | 95 | 120 | 170 | 220 | 270 | 320 | -   |
| TA6R | 42P        | 3         | Horizontal              | 200         |    |    |     |     | 185 | 140 | -   |     |
|      |            |           | Vertical                | 200         |    |    |     |     | 185 | 140 | -   |     |
|      |            | 6         | Horizontal              | 400         |    |    |     |     | 365 | 285 | -   |     |
|      |            |           | Vertical                | 400         |    |    |     |     | 365 | 285 | -   |     |
|      |            | 12        | Horizontal              | 800         |    |    |     |     | 735 | 575 | -   |     |
|      |            |           | Vertical                | 680         |    |    |     |     |     | 575 | -   |     |
|      |            |           |                         | 40          | 65 | 90 | 140 | 190 | 240 | 290 | 340 | 390 |
| TA7R | 56P        | 4         | Horizontal              | 210         |    |    |     |     | 180 | 150 |     |     |
|      |            |           | Vertical                | 210         |    |    |     |     | 180 | 150 |     |     |
|      |            | 8         | Horizontal              | 420         |    |    |     |     | 365 | 300 |     |     |
|      |            |           | Vertical                | 350         |    |    |     |     |     | 300 |     |     |
|      |            | 16        | Horizontal              | 700         |    |    |     |     |     | 600 |     |     |
|      |            |           | Vertical                | 560         |    |    |     |     |     |     |     |     |

 **Caution:** When a speed less than the minimum speed, operation will not made in the set speed.  
 Do not attempt to set a speed less than the minimum speed.  
 Figure out the minimum speed using the following formula.  
 Min. Speed [mm/s] = Lead Length [mm] / 800 / 0.001 [sec]

[When high-output setting for motor straight type is ineffective]

• Standard Specification

Speed limits [Unit: mm/s]

| Type | Motor Type | Lead [mm] | Horizontal/<br>Vertical | Stroke [mm] |    |    |     |     |     |     |     |     |     |
|------|------------|-----------|-------------------------|-------------|----|----|-----|-----|-----|-----|-----|-----|-----|
|      |            |           |                         | 25          | 50 | 75 | 100 | 125 | 150 | —   | —   | —   | —   |
| TA4C | 35P        | 2.5       | Horizontal              | 130         |    |    |     |     |     | —   | —   | —   | —   |
|      |            |           | Vertical                | 130         |    |    |     |     |     | —   | —   | —   | —   |
|      |            | 5         | Horizontal              | 260         |    |    |     |     |     | —   | —   | —   | —   |
|      |            |           | Vertical                | 260         |    |    |     |     |     | —   | —   | —   | —   |
|      |            | 10        | Horizontal              | 525         |    |    |     |     |     | —   | —   | —   | —   |
|      |            |           | Vertical                | 435         |    |    |     |     |     | —   | —   | —   | —   |
|      |            | 16        | Horizontal              | 840         |    |    |     |     |     | —   | —   | —   | —   |
|      |            |           | Vertical                | 560         |    |    |     |     |     | —   | —   | —   | —   |
|      |            |           |                         | 25          | 50 | 75 | 100 | 125 | 150 | 175 | 200 | —   | —   |
| TA6C | 42P        | 3         | Horizontal              | 170         |    |    |     |     |     | —   | —   | —   | —   |
|      |            |           | Vertical                | 140         |    |    |     |     |     | —   | —   | —   | —   |
|      |            | 6         | Horizontal              | 340         |    |    |     |     |     | —   | —   | —   | —   |
|      |            |           | Vertical                | 280         |    |    |     |     |     | —   | —   | —   | —   |
|      |            | 12        | Horizontal              | 680         |    |    |     |     |     | —   | —   | —   | —   |
|      |            |           | Vertical                | 560         |    |    |     |     |     | —   | —   | —   | —   |
|      |            | 20        | Horizontal              | 800         |    |    |     |     |     | —   | —   | —   | —   |
|      |            |           | Vertical                | 640         |    |    |     |     |     | —   | —   | —   | —   |
|      |            |           |                         | 25          | 50 | 75 | 100 | 125 | 150 | 175 | 200 | 250 | 300 |
| TA7C | 56P        | 4         | Horizontal              | 140         |    |    |     |     |     | —   | —   | —   | —   |
|      |            |           | Vertical                | 105         |    |    |     |     |     | —   | —   | —   | —   |
|      |            | 8         | Horizontal              | 280         |    |    |     |     |     | —   | —   | —   | —   |
|      |            |           | Vertical                | 210         |    |    |     |     |     | —   | —   | —   | —   |
|      |            | 16        | Horizontal              | 560         |    |    |     |     |     | —   | —   | —   | —   |
|      |            |           | Vertical                | 280         |    |    |     |     |     | —   | —   | —   | —   |
|      |            | 24        | Horizontal              | 860         |    |    |     |     |     | —   | —   | —   | —   |
|      |            |           | Vertical                | 420         |    |    |     |     |     | —   | —   | —   | —   |

[When high-output setting for motor straight type is ineffective]

- Double Guide Block (Option Model: DB)

Speed limits [Unit: mm/s]

| Type | Motor Type | Lead [mm] | Horizontal/<br>Vertical | Stroke [mm] |    |    |     |     |     |     |     |     |
|------|------------|-----------|-------------------------|-------------|----|----|-----|-----|-----|-----|-----|-----|
|      |            |           |                         | 40          | 65 | 90 | 140 | 190 | 240 | —   | —   | —   |
| TA4C | 35P        | 2.5       | Horizontal              | 130         |    |    |     |     | —   | —   | —   |     |
|      |            |           | Vertical                | 130         |    |    |     |     | —   | —   | —   |     |
|      |            | 5         | Horizontal              | 260         |    |    |     |     | —   | —   | —   |     |
|      |            |           | Vertical                | 260         |    |    |     |     | —   | —   | —   |     |
|      |            | 10        | Horizontal              | 525         |    |    |     |     | —   | —   | —   |     |
|      |            |           | Vertical                | 435         |    |    |     |     | —   | —   | —   |     |
|      |            |           |                         | 45          | 70 | 95 | 120 | 170 | 220 | 270 | 320 | —   |
| TA6C | 42P        | 3         | Horizontal              | 170         |    |    |     |     |     | 140 | —   |     |
|      |            |           | Vertical                | 140         |    |    |     |     |     | —   | —   |     |
|      |            | 6         | Horizontal              | 340         |    |    |     |     |     | 285 | —   |     |
|      |            |           | Vertical                | 280         |    |    |     |     |     | —   | —   |     |
|      |            | 12        | Horizontal              | 560         |    |    |     |     |     | —   | —   |     |
|      |            |           | Vertical                | 440         |    |    |     |     |     | —   | —   |     |
|      |            |           |                         | 40          | 65 | 90 | 140 | 190 | 240 | 290 | 340 | 390 |
| TA7C | 56P        | 4         | Horizontal              | 105         |    |    |     |     | —   | —   | —   |     |
|      |            |           | Vertical                | 105         |    |    |     |     | —   | —   | —   |     |
|      |            | 8         | Horizontal              | 280         |    |    |     |     | —   | —   | —   |     |
|      |            |           | Vertical                | 210         |    |    |     |     | —   | —   | —   |     |
|      |            | 16        | Horizontal              | 560         |    |    |     |     | —   | —   | —   |     |
|      |            |           | Vertical                | 280         |    |    |     |     | —   | —   | —   |     |

[When high-output setting for side-mounted motor type is ineffective]

• Standard Specification

Speed limits [Unit: mm/s]

| Type | Motor Type | Lead [mm] | Horizontal/<br>Vertical | Stroke [mm] |    |    |     |     |     |     |     |     |     |
|------|------------|-----------|-------------------------|-------------|----|----|-----|-----|-----|-----|-----|-----|-----|
|      |            |           |                         | 25          | 50 | 75 | 100 | 125 | 150 | —   | —   | —   | —   |
| TA4R | 35P        | 2.5       | Horizontal              | 130         |    |    |     |     |     | —   | —   | —   | —   |
|      |            |           | Vertical                | 130         |    |    |     |     |     | —   | —   | —   | —   |
|      |            | 5         | Horizontal              | 260         |    |    |     |     |     | —   | —   | —   | —   |
|      |            |           | Vertical                | 260         |    |    |     |     |     | —   | —   | —   | —   |
|      |            | 10        | Horizontal              | 525         |    |    |     |     |     | —   | —   | —   | —   |
|      |            |           | Vertical                | 435         |    |    |     |     |     | —   | —   | —   | —   |
| 16   | Horizontal | 840       |                         |             |    |    |     | —   | —   | —   | —   |     |     |
|      | Vertical   | 560       |                         |             |    |    |     | —   | —   | —   | —   |     |     |
|      |            |           |                         | 25          | 50 | 75 | 100 | 125 | 150 | 175 | 200 | —   | —   |
| TA6R | 42P        | 3         | Horizontal              | 170         |    |    |     |     |     | —   | —   | —   | —   |
|      |            |           | Vertical                | 140         |    |    |     |     |     | —   | —   | —   | —   |
|      |            | 6         | Horizontal              | 340         |    |    |     |     |     | —   | —   | —   | —   |
|      |            |           | Vertical                | 280         |    |    |     |     |     | —   | —   | —   | —   |
|      |            | 12        | Horizontal              | 680         |    |    |     |     |     | —   | —   | —   | —   |
|      |            |           | Vertical                | 560         |    |    |     |     |     | —   | —   | —   | —   |
| 20   | Horizontal | 800       |                         |             |    |    |     | —   | —   | —   | —   |     |     |
|      | Vertical   | 640       |                         |             |    |    |     | —   | —   | —   | —   |     |     |
|      |            |           |                         | 25          | 50 | 75 | 100 | 125 | 150 | 175 | 200 | 250 | 300 |
| TA7R | 56P        | 4         | Horizontal              | 140         |    |    |     |     |     | —   | —   | —   | —   |
|      |            |           | Vertical                | 105         |    |    |     |     |     | —   | —   | —   | —   |
|      |            | 8         | Horizontal              | 280         |    |    |     |     |     | —   | —   | —   | —   |
|      |            |           | Vertical                | 210         |    |    |     |     |     | —   | —   | —   | —   |
|      |            | 16        | Horizontal              | 560         |    |    |     |     |     | —   | —   | —   | —   |
|      |            |           | Vertical                | 280         |    |    |     |     |     | —   | —   | —   | —   |
| 24   | Horizontal | 860       |                         |             |    |    |     | —   | —   | —   | —   |     |     |
|      | Vertical   | 420       |                         |             |    |    |     | —   | —   | —   | —   |     |     |

[When high-output setting for side-mounted motor type is ineffective]

- Double Guide Block (Option Model: DB)

Speed limits [Unit: mm/s]

| Type | Motor Type | Lead [mm] | Horizontal/<br>Vertical | Stroke [mm] |    |    |     |     |     |     |     |     |
|------|------------|-----------|-------------------------|-------------|----|----|-----|-----|-----|-----|-----|-----|
|      |            |           |                         | 40          | 65 | 90 | 140 | 190 | 240 | —   | —   | —   |
| TA4R | 35P        | 2.5       | Horizontal              | 130         |    |    |     |     | —   | —   | —   |     |
|      |            |           | Vertical                | 130         |    |    |     |     | —   | —   | —   |     |
|      |            | 5         | Horizontal              | 260         |    |    |     |     | —   | —   | —   |     |
|      |            |           | Vertical                | 260         |    |    |     |     | —   | —   | —   |     |
|      |            | 10        | Horizontal              | 525         |    |    |     |     | —   | —   | —   |     |
|      |            |           | Vertical                | 435         |    |    |     |     | —   | —   | —   |     |
|      |            |           |                         | 45          | 70 | 95 | 120 | 170 | 220 | 270 | 320 | —   |
| TA6R | 42P        | 3         | Horizontal              | 170         |    |    |     |     |     | 140 | —   |     |
|      |            |           | Vertical                | 140         |    |    |     |     |     | —   | —   |     |
|      |            | 6         | Horizontal              | 340         |    |    |     |     |     | 285 | —   |     |
|      |            |           | Vertical                | 280         |    |    |     |     |     | —   | —   |     |
|      |            | 12        | Horizontal              | 560         |    |    |     |     |     | —   | —   |     |
|      |            |           | Vertical                | 440         |    |    |     |     |     | —   | —   |     |
|      |            |           |                         | 40          | 65 | 90 | 140 | 190 | 240 | 290 | 340 | 390 |
| TA7R | 56P        | 4         | Horizontal              | 105         |    |    |     |     | —   | —   | —   |     |
|      |            |           | Vertical                | 105         |    |    |     |     | —   | —   | —   |     |
|      |            | 8         | Horizontal              | 280         |    |    |     |     | —   | —   | —   |     |
|      |            |           | Vertical                | 210         |    |    |     |     | —   | —   | —   |     |
|      |            | 16        | Horizontal              | 560         |    |    |     |     | —   | —   | —   |     |
|      |            |           | Vertical                | 280         |    |    |     |     | —   | —   | —   |     |

 **Caution:** When a speed less than the minimum speed, operation will not be made in the set speed.  
 Do not attempt to set a speed less than the minimum speed.  
 Figure out the minimum speed using the following formula.  
 Min. Speed [mm/s] = Lead Length [mm] / 800 / 0.001 [sec]

### 1.2.2 Maximum Acceleration and Transportable Mass

If the transportable mass is smaller than as specified, the acceleration/deceleration can be raised beyond the applicable level.

[When high-output setting for motor straight type is effective]

(Note) If the stroke is long, lighten the transportable mass according to the graph in "1.2.3 Allowable Transportable Mass".

• Standard Specification

| Type | Motor Type | Lead [mm] | Horizontal/<br>Vertical | Transportable Mass by Acceleration/Deceleration [kg] |      |      |      |      |      |
|------|------------|-----------|-------------------------|--|------|------|------|------|------|
|      |            |           |                         | Velocity [mm/s]                                      | 0.1G | 0.3G | 0.5G | 0.7G | 1.0G |
| TA4C | 35P        | 2.5       | Horizontal              | 0  | 5    | 5    | 5    | 5    | 5    |
|      |            |           |                         | 20   | 5    | 5    | 5    | 5    | 5    |
|      |            |           |                         | 40   | 5    | 5    | 5    | 5    | 5    |
|      |            |           |                         | 65   | 5    | 5    | 5    | 5    | 5    |
|      |            |           |                         | 85   | 5    | 5    | 5    | 5    | 5    |
|      |            |           |                         | 105  | 5    | 5    | 5    | 5    | 5    |
|      |            |           |                         | 130  | 5    | 5    | 5    | 5    | 4.5  |
|      |            |           |                         | 150  | 5    | 5    | 5    | 5    | 4    |
|      |            |           |                         | 175  | 5    | 5    | 5    | 4    | 3.5  |
|      |            |           | 195                     | 5  | 5    | 5    | 4    | 3    |      |
|      |            |           | Vertical                | 0  | 10   | 9    | 8    | -    | -    |
|      |            |           |                         | 20   | 10   | 9    | 8    | -    | -    |
|      |            |           |                         | 40   | 10   | 9    | 8    | -    | -    |
|      |            |           |                         | 65   | 10   | 9    | 8    | -    | -    |
|      |            |           |                         | 85   | 10   | 9    | 7    | -    | -    |
|      |            |           |                         | 105  | 10   | 8    | 7    | -    | -    |
|      |            |           |                         | 130  | 10   | 8    | 6    | -    | -    |
|      |            |           |                         | 150  | 9    | 7    | 6    | -    | -    |
|      |            | 175       |                         | 8  | 7    | 5    | -    | -    |      |
|      |            | 195       | 6                       | 5  | 5    | -    | -    |      |      |
|      |            | 5         | Horizontal              | 0  | 5    | 5    | 5    | 5    | 5    |
|      |            |           |                         | 40   | 5    | 5    | 5    | 5    | 5    |
|      |            |           |                         | 85   | 5    | 5    | 5    | 5    | 5    |
|      |            |           |                         | 130  | 5    | 5    | 5    | 5    | 5    |
|      |            |           |                         | 175  | 5    | 5    | 5    | 5    | 5    |
|      |            |           |                         | 215  | 5    | 5    | 5    | 5    | 5    |
|      |            |           |                         | 260  | 5    | 5    | 5    | 5    | 4.5  |
|      |            |           |                         | 305  | 5    | 5    | 5    | 5    | 4.   |
|      |            |           |                         | 350  | 5    | 5    | 5    | 4    | 3.5  |
|      |            |           | 390                     | -  | 5    | 5    | 4    | 3    |      |
|      |            |           | Vertical                | 0  | 5    | 5    | 5    | -    | -    |
|      |            |           |                         | 40   | 5    | 5    | 5    | -    | -    |
|      |            |           |                         | 85   | 5    | 5    | 5    | -    | -    |
|      |            |           |                         | 130  | 5    | 5    | 5    | -    | -    |
|      |            |           |                         | 175  | 5    | 5    | 5    | -    | -    |
|      |            |           |                         | 215  | 5    | 5    | 5    | -    | -    |
| 260  | 5          |           |                         | 5  | 5    | -    | -    |      |      |
| 305  | 4.5        |           |                         | 4.5  | 4.5  | -    | -    |      |      |
| 350  | 4          | 3.5       |                         | 3.5  | -    | -    |      |      |      |
| 390  | -          | 2.5       | 2.5                     | -  | -    |      |      |      |      |

[When high-output setting for motor straight type is effective]

(Note) If the stroke is long, lighten the transportable mass according to the graph in "1.2.3 Allowable Transportable Mass".

• Standard Specification

| Type | Motor Type | Lead [mm] | Horizontal/<br>Vertical | Transportable Mass by Acceleration/Deceleration [kg] |      |      |      |      |      |
|------|------------|-----------|-------------------------|--|------|------|------|------|------|
|      |            |           |                         | Velocity [mm/s]                                      | 0.1G | 0.3G | 0.5G | 0.7G | 1.0G |
| TA4C | 35P        | 10        | Horizontal              | 0  | 4    | 4    | 4    | 4    | 4    |
|      |            |           |                         | 85   | 4    | 4    | 4    | 4    | 4    |
|      |            |           |                         | 175  | 4    | 4    | 4    | 4    | 4    |
|      |            |           |                         | 260  | 4    | 4    | 4    | 4    | 4    |
|      |            |           |                         | 350  | 4    | 4    | 4    | 4    | 4    |
|      |            |           |                         | 435  | -    | 4    | 4    | 4    | 4    |
|      |            |           |                         | 525  | -    | -    | 4    | 4    | 4    |
|      |            |           |                         | 610  | -    | -    | 4    | 4    | 4    |
|      |            |           |                         | 700  | -    | -    | 4    | 4    | 2.5  |
|      |            |           | 785                     | -  | -    | -    | 2.5  | 2    |      |
|      |            |           | Vertical                | 0  | 2.5  | 2.5  | 2    | -    | -    |
|      |            |           |                         | 85   | 2.5  | 2.5  | 2    | -    | -    |
|      |            |           |                         | 175  | 2.5  | 2.5  | 2    | -    | -    |
|      |            |           |                         | 260  | 2.5  | 2.5  | 2    | -    | -    |
|      |            |           |                         | 350  | 2.5  | 2.5  | 2    | -    | -    |
|      |            |           |                         | 435  | -    | 2.5  | 2    | -    | -    |
|      |            |           |                         | 525  | -    | -    | 2    | -    | -    |
|      |            |           |                         | 610  | -    | -    | 1.5  | -    | -    |
|      |            | 700       |                         | -  | -    | 1    | -    | -    |      |
|      |            | 785       | -                       | -  | -    | -    | -    |      |      |
|      |            | 16        | Horizontal              | 0  | 3    | 3    | 3    | 3    | 3    |
|      |            |           |                         | 140  | 3    | 3    | 3    | 3    | 3    |
|      |            |           |                         | 280  | 3    | 3    | 3    | 3    | 3    |
|      |            |           |                         | 420  | -    | 3    | 3    | 3    | 3    |
|      |            |           |                         | 560  | -    | 3    | 3    | 3    | 3    |
|      |            |           |                         | 700  | -    | -    | 3    | 3    | 3    |
|      |            |           |                         | 840  | -    | -    | -    | 3    | 3    |
|      |            |           |                         | 980  | -    | -    | -    | -    | 2    |
|      |            |           |                         | 1120   | -    | -    | -    | -    | -    |
|      |            |           | 1260                    | -  | -    | -    | -    | -    |      |
|      |            |           | Vertical                | 0  | 1    | 1    | 1    | -    | -    |
|      |            |           |                         | 140  | 1    | 1    | 1    | -    | -    |
|      |            |           |                         | 280  | 1    | 1    | 1    | -    | -    |
|      |            |           |                         | 420  | -    | 1    | 1    | -    | -    |
|      |            |           |                         | 560  | -    | 1    | 1    | -    | -    |
|      |            |           |                         | 700  | -    | -    | 1    | -    | -    |
| 840  | -          |           |                         | -  | -    | -    | -    |      |      |
| 980  | -          |           |                         | -  | -    | -    | -    |      |      |
| 1120 | -          | -         |                         | -  | -    | -    |      |      |      |
| 1260 | -          | -         | -                       | -  | -    |      |      |      |      |

[When high-output setting for motor straight type is effective]

(Note) If the stroke is long, lighten the transportable mass according to the graph in "1.2.3 Allowable Transportable Mass".

• Standard Specification

| Type | Motor Type | Lead [mm] | Horizontal/<br>Vertical | Transportable Mass by Acceleration/Deceleration [kg] |      |      |      |      |      |
|------|------------|-----------|-------------------------|--|------|------|------|------|------|
|      |            |           |                         | Velocity [mm/s]                                      | 0.1G | 0.3G | 0.5G | 0.7G | 1.0G |
| TA6C | 42P        | 3         | Horizontal              | 0  | 10   | 10   | 10   | 8    | 7    |
|      |            |           |                         | 20   | 10   | 10   | 10   | 8    | 7    |
|      |            |           |                         | 50   | 10   | 10   | 10   | 8    | 7    |
|      |            |           |                         | 80   | 10   | 10   | 10   | 8    | 7    |
|      |            |           |                         | 110  | 10   | 10   | 10   | 8    | 7    |
|      |            |           |                         | 125  | 10   | 10   | 10   | 8    | 7    |
|      |            |           |                         | 140  | 10   | 10   | 10   | 8    | 7    |
|      |            |           | 170                     | 10   | 10   | 8    | 7    | 6    |      |
|      |            |           | 200                     | 10   | 8    | 7    | 6    | 4    |      |
|      |            |           | Vertical                | 0  | 12   | 12   | 10   | -    | -    |
|      |            |           |                         | 20   | 12   | 12   | 10   | -    | -    |
|      |            |           |                         | 50   | 12   | 12   | 10   | -    | -    |
|      |            |           |                         | 80   | 12   | 12   | 10   | -    | -    |
|      |            |           |                         | 110  | 12   | 12   | 10   | -    | -    |
|      |            | 125       |                         | 12   | 12   | 10   | -    | -    |      |
|      |            | 140       |                         | 12   | 12   | 10   | -    | -    |      |
|      |            | 170       | 12                      | 10   | 9    | -    | -    |      |      |
|      |            | 200       | 10                      | 8  | 8    | -    | -    |      |      |
|      |            | 6         | Horizontal              | 0  | 10   | 10   | 9    | 8    | 7    |
|      |            |           |                         | 40   | 10   | 10   | 9    | 8    | 7    |
|      |            |           |                         | 100  | 10   | 10   | 9    | 8    | 7    |
|      |            |           |                         | 160  | 10   | 10   | 9    | 8    | 7    |
|      |            |           |                         | 220  | 10   | 10   | 9    | 8    | 7    |
|      |            |           |                         | 250  | 10   | 10   | 9    | 8    | 7    |
|      |            |           |                         | 280  | 10   | 10   | 9    | 8    | 7    |
|      |            |           | 340                     | 10   | 10   | 9    | 8    | 7    |      |
|      |            |           | 400                     | 10   | 9    | 8    | 7    | 6    |      |
|      |            |           | Vertical                | 0  | 6    | 6    | 6    | -    | -    |
| 40   | 6          |           |                         | 6  | 6    | -    | -    |      |      |
| 100  | 6          |           |                         | 6  | 6    | -    | -    |      |      |
| 160  | 6          |           |                         | 6  | 6    | -    | -    |      |      |
| 220  | 6          |           |                         | 6  | 6    | -    | -    |      |      |
| 250  | 6          | 6         |                         | 5.5  | -    | -    |      |      |      |
| 280  | 6          | 5.5       |                         | 5  | -    | -    |      |      |      |
| 340  | 6          | 4.5       | 4                       | -  | -    |      |      |      |      |
| 400  | 4.5        | 3.5       | 3                       | -  | -    |      |      |      |      |

[When high-output setting for motor straight type is effective]

(Note) If the stroke is long, lighten the transportable mass according to the graph in "1.2.3 Allowable Transportable Mass".

• Standard Specification

| Type | Motor Type | Lead [mm] | Horizontal/<br>Vertical | Transportable Mass by Acceleration/Deceleration [kg] |      |      |      |      |      |
|------|------------|-----------|-------------------------|--|------|------|------|------|------|
|      |            |           |                         | Velocity [mm/s]                                      | 0.1G | 0.3G | 0.5G | 0.7G | 1.0G |
| TA6C | 42P        | 12        | Horizontal              | 0  | 8    | 8    | 8    | 7    | 6    |
|      |            |           |                         | 80   | 8    | 8    | 8    | 7    | 6    |
|      |            |           |                         | 200  | 8    | 8    | 8    | 7    | 6    |
|      |            |           |                         | 320  | 8    | 8    | 8    | 7    | 6    |
|      |            |           |                         | 440  | 8    | 8    | 8    | 7    | 6    |
|      |            |           |                         | 500  | -    | 8    | 8    | 7    | 6    |
|      |            |           |                         | 560  | -    | 8    | 8    | 6    | 4    |
|      |            |           |                         | 680  | -    | 8    | 7    | 4    | 2.5  |
|      |            |           | 800                     | -  | -    | 5    | 2    | 1    |      |
|      |            |           | Vertical                | 0  | 3    | 3    | 3    | -    | -    |
|      |            |           |                         | 80   | 3    | 3    | 3    | -    | -    |
|      |            |           |                         | 200  | 3    | 3    | 3    | -    | -    |
|      |            |           |                         | 320  | 3    | 3    | 3    | -    | -    |
|      |            |           |                         | 440  | 3    | 3    | 3    | -    | -    |
|      |            |           |                         | 500  | -    | 3    | 3    | -    | -    |
|      |            |           |                         | 560  | -    | 3    | 2.5  | -    | -    |
|      |            | 680       |                         | -  | 2    | 1.5  | -    | -    |      |
|      |            | 800       | -                       | -  | 0.5  | -    | -    |      |      |
|      |            | 20        | Horizontal              | 0  | 5    | 5    | 5    | 5    | 5    |
|      |            |           |                         | 160  | 5    | 5    | 5    | 5    | 5    |
|      |            |           |                         | 320  | 5    | 5    | 5    | 5    | 5    |
|      |            |           |                         | 480  | -    | 5    | 5    | 5    | 5    |
|      |            |           |                         | 640  | -    | 5    | 5    | 5    | 5    |
|      |            |           |                         | 800  | -    | -    | 5    | 4.5  | 4    |
|      |            |           | 960                     | -  | -    | -    | 3.5  | 2    |      |
|      |            |           | 1120                    | -  | -    | -    | -    | 1.5  |      |
|      |            |           | Vertical                | 0  | 1    | 1    | 1    | -    | -    |
|      |            |           |                         | 160  | 1    | 1    | 1    | -    | -    |
| 320  | 1          |           |                         | 1  | 1    | -    | -    |      |      |
| 480  | -          |           |                         | 1  | 1    | -    | -    |      |      |
| 640  | -          | 1         |                         | 1  | -    | -    |      |      |      |
| 800  | -          | -         |                         | 1  | -    | -    |      |      |      |
| 960  | -          | -         | -                       | -  | -    |      |      |      |      |
| 1120 | -          | -         | -                       | -  | -    |      |      |      |      |

[When high-output setting for motor straight type is effective]

(Note) If the stroke is long, lighten the transportable mass according to the graph in "1.2.3 Allowable Transportable Mass".

• Standard Specification

| Type | Motor Type | Lead [mm] | Horizontal/ Vertical | Transportable Mass by Acceleration/Deceleration [kg] |      |      |      |      |      |
|------|------------|-----------|----------------------|--|------|------|------|------|------|
|      |            |           |                      | Velocity [mm/s]                                      | 0.1G | 0.3G | 0.5G | 0.7G | 1.0G |
| TA7C | 56P        | 4         | Horizontal           | 0  | 15   | 15   | 15   | 15   | 15   |
|      |            |           |                      | 35   | 15   | 15   | 15   | 15   | 15   |
|      |            |           |                      | 70   | 15   | 15   | 15   | 15   | 15   |
|      |            |           |                      | 105  | 15   | 15   | 15   | 15   | 12   |
|      |            |           |                      | 140  | 15   | 15   | 15   | 12   | 10   |
|      |            |           |                      | 175  | 15   | 12   | 10   | -    | -    |
|      |            |           | 210                  | 10   | -    | -    | -    | -    |      |
|      |            |           | Vertical             | 0  | 20   | 20   | 20   | -    | -    |
|      |            |           |                      | 35   | 20   | 20   | 20   | -    | -    |
|      |            |           |                      | 70   | 20   | 18   | 14   | -    | -    |
|      |            |           |                      | 105  | 18   | 16   | 10   | -    | -    |
|      |            |           |                      | 140  | 16   | 12   | 6    | -    | -    |
|      |            | 175       |                      | 10   | 6    | -    | -    | -    |      |
|      |            | 210       | 6                    | -  | -    | -    | -    |      |      |
|      |            | 8         | Horizontal           | 0  | 15   | 15   | 15   | 15   | 15   |
|      |            |           |                      | 70   | 15   | 15   | 15   | 15   | 15   |
|      |            |           |                      | 140  | 15   | 15   | 15   | 15   | 12   |
|      |            |           |                      | 210  | 15   | 15   | 15   | 12   | 10   |
|      |            |           |                      | 280  | 15   | 15   | 12   | 10   | 8    |
|      |            |           |                      | 350  | 12   | 10   | 8    | -    | -    |
|      |            |           | 420                  | 8  | -    | -    | -    | -    |      |
|      |            |           | Vertical             | 0  | 16   | 14   | 12   | -    | -    |
|      |            |           |                      | 70   | 16   | 14   | 12   | -    | -    |
|      |            |           |                      | 140  | 16   | 14   | 10   | -    | -    |
| 210  | 12         |           |                      | 10   | 8    | -    | -    |      |      |
| 280  | 9          |           |                      | 8  | 6    | -    | -    |      |      |
| 350  | 6          | -         |                      | -  | -    | -    |      |      |      |
| 420  | -          | -         | -                    | -  | -    |      |      |      |      |

[When high-output setting for motor straight type is effective]

(Note) If the stroke is long, lighten the transportable mass according to the graph in "1.2.3 Allowable Transportable Mass".

• Standard Specification

| Type | Motor Type | Lead [mm] | Horizontal/ Vertical | Transportable Mass by Acceleration/Deceleration [kg] |      |      |      |      |      |
|------|------------|-----------|----------------------|--|------|------|------|------|------|
|      |            |           |                      | Velocity [mm/s]                                      | 0.1G | 0.3G | 0.5G | 0.7G | 1.0G |
| TA7C | 56P        | 16        | Horizontal           | 0  | 12   | 12   | 12   | 10   | 10   |
|      |            |           |                      | 140  | 12   | 12   | 12   | 10   | 10   |
|      |            |           |                      | 280  | 12   | 12   | 12   | 10   | 10   |
|      |            |           |                      | 420  | 12   | 12   | 12   | 10   | 8    |
|      |            |           |                      | 560  | -    | 12   | 10   | 8    | 5    |
|      |            |           | 700                  | -  | 10   | 6    | 3    | 2    |      |
|      |            |           | Vertical             | 0  | 7    | 7    | 7    | -    | -    |
|      |            |           |                      | 140  | 7    | 7    | 7    | -    | -    |
|      |            |           |                      | 280  | 7    | 7    | 6    | -    | -    |
|      |            |           |                      | 420  | 6    | 5    | 4    | -    | -    |
|      |            | 560       |                      | -  | 3    | 2    | -    | -    |      |
|      |            | 700       | -                    | -  | -    | -    | -    |      |      |
|      |            | 24        | Horizontal           | 0  | 10   | 10   | 10   | 8    | 8    |
|      |            |           |                      | 200  | 10   | 10   | 10   | 8    | 8    |
|      |            |           |                      | 420  | 10   | 10   | 10   | 8    | 8    |
|      |            |           |                      | 640  | -    | 10   | 10   | 8    | 7    |
|      |            |           |                      | 860  | -    | 9    | 7    | 6    | 3    |
|      |            |           | 1080                 | -  | -    | 3.5  | 2    | -    |      |
|      |            |           | Vertical             | 0  | 3    | 3    | 3    | -    | -    |
|      |            |           |                      | 200  | 3    | 3    | 3    | -    | -    |
| 420  | 3          |           |                      | 3  | 3    | -    | -    |      |      |
| 640  | -          |           |                      | 3  | 3    | -    | -    |      |      |
| 860  | -          | 1.5       |                      | 1  | -    | -    |      |      |      |
| 1080 | -          | -         | -                    | -  | -    |      |      |      |      |

[When high-output setting for motor straight type is effective]

(Note) If the stroke is long, lighten the transportable mass according to the graph in "1.2.3 Allowable Transportable Mass".

• Double Guide Block (Option Model: DB)

| Type | Motor Type | Lead [mm] | Horizontal/<br>Vertical | Transportable Mass by Acceleration/Deceleration [kg] |      |      |      |      |      |
|------|------------|-----------|-------------------------|--|------|------|------|------|------|
|      |            |           |                         | Velocity [mm/s]                                      | 0.1G | 0.3G | 0.5G | 0.7G | 1.0G |
| TA4C | 35P        | 2.5       | Horizontal              | 0  | 10   | 10   | 9    | 8    | 6    |
|      |            |           |                         | 20   | 10   | 10   | 9    | 8    | 6    |
|      |            |           |                         | 40   | 10   | 10   | 9    | 8    | 6    |
|      |            |           |                         | 65   | 10   | 9    | 9    | 8    | 6    |
|      |            |           |                         | 85   | 10   | 9    | 8    | 6    | 6    |
|      |            |           |                         | 105  | 10   | 9    | 8    | 6    | 5    |
|      |            |           |                         | 130  | 9    | 8    | 7    | 5    | 4.5  |
|      |            |           |                         | 150  | 9    | 8    | 6    | 5    | 4    |
|      |            |           |                         | 175  | 8    | 7    | 6    | 4    | 3.5  |
|      |            |           | 195                     | 8  | 7    | 6    | 4    | 3    |      |
|      |            |           | Vertical                | 0  | 10   | 9    | 8    | -    | -    |
|      |            |           |                         | 20   | 10   | 9    | 8    | -    | -    |
|      |            |           |                         | 40   | 10   | 9    | 8    | -    | -    |
|      |            |           |                         | 65   | 10   | 9    | 8    | -    | -    |
|      |            |           |                         | 85   | 10   | 9    | 7    | -    | -    |
|      |            |           |                         | 105  | 10   | 8    | 7    | -    | -    |
|      |            |           |                         | 130  | 10   | 8    | 6    | -    | -    |
|      |            |           |                         | 150  | 9    | 7    | 6    | -    | -    |
|      |            | 175       |                         | 8  | 7    | 5    | -    | -    |      |
|      |            | 195       | 6                       | 5  | 5    | -    | -    |      |      |
|      |            | 5         | Horizontal              | 0  | 10   | 10   | 9    | 8    | 6    |
|      |            |           |                         | 40   | 10   | 10   | 9    | 8    | 6    |
|      |            |           |                         | 85   | 10   | 10   | 9    | 8    | 6    |
|      |            |           |                         | 130  | 10   | 9    | 9    | 8    | 6    |
|      |            |           |                         | 175  | 10   | 9    | 8    | 6    | 6    |
|      |            |           |                         | 215  | 10   | 9    | 8    | 6    | 5    |
|      |            |           |                         | 260  | 9    | 8    | 7    | 5    | 4.5  |
|      |            |           |                         | 305  | 9    | 8    | 6    | 5    | 4    |
|      |            |           |                         | 350  | 8    | 7    | 6    | 4    | 3.5  |
|      |            |           | 390                     | -  | 7    | 6    | 4    | 3    |      |
|      |            |           | Vertical                | 0  | 5    | 5    | 5    | -    | -    |
|      |            |           |                         | 40   | 5    | 5    | 5    | -    | -    |
|      |            |           |                         | 85   | 5    | 5    | 5    | -    | -    |
|      |            |           |                         | 130  | 5    | 5    | 5    | -    | -    |
|      |            |           |                         | 175  | 5    | 5    | 5    | -    | -    |
|      |            |           |                         | 215  | 5    | 5    | 5    | -    | -    |
| 260  | 5          |           |                         | 5  | 5    | -    | -    |      |      |
| 305  | 4.5        |           |                         | 4.5  | 4.5  | -    | -    |      |      |
| 350  | 3.5        | 3         |                         | 3  | -    | -    |      |      |      |
| 390  | -          | 2         | 2                       | -  | -    |      |      |      |      |

[When high-output setting for motor straight type is effective]

(Note) If the stroke is long, lighten the transportable mass according to the graph in "1.2.3 Allowable Transportable Mass".

• Double Guide Block (Option Model: DB)

| Type | Motor Type | Lead [mm] | Horizontal/<br>Vertical | Transportable Mass by Acceleration/Deceleration [kg] |      |      |      |      |      |
|------|------------|-----------|-------------------------|--|------|------|------|------|------|
|      |            |           |                         | Velocity [mm/s]                                      | 0.1G | 0.3G | 0.5G | 0.7G | 1.0G |
| TA4C | 35P        | 10        | Horizontal              | 0  | 8    | 8    | 8    | 8    | 6    |
|      |            |           |                         | 85   | 8    | 8    | 8    | 8    | 6    |
|      |            |           |                         | 175  | 8    | 8    | 8    | 8    | 6    |
|      |            |           |                         | 260  | 8    | 8    | 8    | 8    | 6    |
|      |            |           |                         | 350  | 8    | 8    | 8    | 6    | 6    |
|      |            |           |                         | 435  | -    | 8    | 8    | 6    | 5    |
|      |            |           |                         | 525  | -    | -    | 8    | 5    | 4.5  |
|      |            |           |                         | 610  | -    | -    | 6    | 4.5  | 4    |
|      |            |           |                         | 700  | -    | -    | 4    | 3.5  | 2.5  |
|      |            |           | 785                     | -  | -    | -    | 2    | 2    |      |
|      |            |           | Vertical                | 0  | 2.5  | 2.5  | 2    | -    | -    |
|      |            |           |                         | 85   | 2.5  | 2.5  | 2    | -    | -    |
|      |            |           |                         | 175  | 2.5  | 2.5  | 2    | -    | -    |
|      |            |           |                         | 260  | 2.5  | 2.5  | 2    | -    | -    |
|      |            |           |                         | 350  | 2.5  | 2.5  | 2    | -    | -    |
|      |            |           |                         | 435  | -    | 2.5  | 2    | -    | -    |
|      |            |           |                         | 525  | -    | -    | 2    | -    | -    |
|      |            |           |                         | 610  | -    | -    | 1.5  | -    | -    |
| 700  | -          | -         |                         | 0.5  | -    | -    |      |      |      |
| 785  | -          | -         | -                       | -  | -    |      |      |      |      |

[When high-output setting for motor straight type is effective]

(Note) If the stroke is long, lighten the transportable mass according to the graph in "1.2.3 Allowable Transportable Mass".

• Double Guide Block (Option Model: DB)

| Type | Motor Type | Lead [mm] | Horizontal/<br>Vertical | Transportable Mass by Acceleration/Deceleration [kg] |      |      |      |      |      |
|------|------------|-----------|-------------------------|--|------|------|------|------|------|
|      |            |           |                         | Velocity [mm/s]                                      | 0.1G | 0.3G | 0.5G | 0.7G | 1.0G |
| TA6C | 42P        | 3         | Horizontal              | 0  | 20   | 20   | 18   | 16   | 15   |
|      |            |           |                         | 20   | 20   | 20   | 18   | 16   | 15   |
|      |            |           |                         | 50   | 20   | 20   | 18   | 16   | 15   |
|      |            |           |                         | 80   | 20   | 20   | 18   | 16   | 15   |
|      |            |           |                         | 110  | 20   | 20   | 18   | 16   | 15   |
|      |            |           |                         | 125  | 20   | 20   | 18   | 16   | 15   |
|      |            |           |                         | 140  | 20   | 20   | 18   | 16   | 15   |
|      |            |           | 170                     | 20   | 18   | 16   | 14   | 12   |      |
|      |            |           | 200                     | 18   | 16   | 14   | 12   | 10   |      |
|      |            |           | Vertical                | 0  | 12   | 12   | 10   | -    | -    |
|      |            |           |                         | 20   | 12   | 12   | 10   | -    | -    |
|      |            |           |                         | 50   | 12   | 12   | 10   | -    | -    |
|      |            |           |                         | 80   | 12   | 12   | 10   | -    | -    |
|      |            |           |                         | 110  | 12   | 12   | 10   | -    | -    |
|      |            | 125       |                         | 12   | 12   | 10   | -    | -    |      |
|      |            | 140       |                         | 12   | 12   | 10   | -    | -    |      |
|      |            | 170       | 12                      | 10   | 9    | -    | -    |      |      |
|      |            | 200       | 9                       | 8  | 8    | -    | -    |      |      |
|      |            | 6         | Horizontal              | 0  | 20   | 20   | 18   | 16   | 14   |
|      |            |           |                         | 40   | 20   | 20   | 18   | 16   | 14   |
|      |            |           |                         | 100  | 20   | 20   | 18   | 16   | 14   |
|      |            |           |                         | 160  | 20   | 20   | 18   | 16   | 14   |
|      |            |           |                         | 220  | 20   | 20   | 18   | 16   | 14   |
|      |            |           |                         | 250  | 20   | 20   | 18   | 16   | 14   |
|      |            |           |                         | 280  | 20   | 18   | 16   | 15   | 11   |
|      |            |           | 340                     | 20   | 16   | 14   | 12   | 9    |      |
|      |            |           | 400                     | 18   | 14   | 10   | 8    | 6    |      |
|      |            |           | Vertical                | 0  | 6    | 6    | 6    | -    | -    |
| 40   | 6          |           |                         | 6  | 6    | -    | -    |      |      |
| 100  | 6          |           |                         | 6  | 6    | -    | -    |      |      |
| 160  | 6          |           |                         | 6  | 6    | -    | -    |      |      |
| 220  | 6          |           |                         | 6  | 6    | -    | -    |      |      |
| 250  | 6          | 6         |                         | 5.5  | -    | -    |      |      |      |
| 280  | 6          | 5.5       |                         | 5  | -    | -    |      |      |      |
| 340  | 6          | 4.5       | 4                       | -  | -    |      |      |      |      |
| 400  | 4.5        | 3.5       | 3                       | -  | -    |      |      |      |      |

[When high-output setting for motor straight type is effective]

(Note) If the stroke is long, lighten the transportable mass according to the graph in "1.2.3 Allowable Transportable Mass".

• Double Guide Block (Option Model: DB)

| Type | Motor Type | Lead [mm] | Horizontal/<br>Vertical | Transportable Mass by Acceleration/Deceleration [kg] |      |      |      |      |      |
|------|------------|-----------|-------------------------|--|------|------|------|------|------|
|      |            |           |                         | Velocity [mm/s]                                      | 0.1G | 0.3G | 0.5G | 0.7G | 1.0G |
| TA6C | 42P        | 12        | Horizontal              | 0  | 15   | 15   | 12   | 11   | 10   |
|      |            |           |                         | 80   | 15   | 15   | 12   | 11   | 10   |
|      |            |           |                         | 200  | 15   | 15   | 12   | 11   | 10   |
|      |            |           |                         | 320  | 15   | 15   | 12   | 11   | 10   |
|      |            |           |                         | 440  | 15   | 14   | 11   | 10   | 8    |
|      |            |           |                         | 500  | -    | 13   | 10   | 8    | 6    |
|      |            |           |                         | 560  | -    | 12   | 9    | 6    | 4    |
|      |            |           |                         | 680  | -    | 10   | 7    | 4    | 2    |
|      |            |           | 800                     | -  | -    | 5    | 2    | 1    |      |
|      |            |           | Vertical                | 0  | 3    | 3    | 3    | -    | -    |
|      |            |           |                         | 80   | 3    | 3    | 3    | -    | -    |
|      |            |           |                         | 200  | 3    | 3    | 3    | -    | -    |
|      |            |           |                         | 320  | 3    | 3    | 3    | -    | -    |
|      |            |           |                         | 440  | 3    | 3    | 3    | -    | -    |
|      |            |           |                         | 500  | -    | 3    | 3    | -    | -    |
|      |            |           |                         | 560  | -    | 3    | 2.5  | -    | -    |
| 680  | -          | 1.5       |                         | 1  | -    | -    |      |      |      |
| 800  | -          | -         | -                       | -  | -    |      |      |      |      |

[When high-output setting for motor straight type is effective]

(Note) If the stroke is long, lighten the transportable mass according to the graph in "1.2.3 Allowable Transportable Mass".

• Double Guide Block (Option Model: DB)

| Type | Motor Type | Lead [mm] | Horizontal/<br>Vertical | Transportable Mass by Acceleration/Deceleration [kg] |      |      |      |      |      |
|------|------------|-----------|-------------------------|--|------|------|------|------|------|
|      |            |           |                         | Velocity [mm/s]                                      | 0.1G | 0.3G | 0.5G | 0.7G | 1.0G |
| TA7C | 56P        | 4         | Horizontal              | 0  | 30   | 30   | 28   | 26   | 24   |
|      |            |           |                         | 35   | 30   | 30   | 28   | 26   | 24   |
|      |            |           |                         | 70   | 30   | 28   | 24   | 22   | 20   |
|      |            |           |                         | 105  | 25   | 22   | 20   | 18   | 16   |
|      |            |           |                         | 140  | 20   | 18   | 16   | 12   | 10   |
|      |            |           |                         | 175  | 14   | 12   | 6    | -    | -    |
|      |            |           | 210                     | 7  | -    | -    | -    | -    |      |
|      |            |           | Vertical                | 0  | 24   | 24   | 24   | -    | -    |
|      |            |           |                         | 35   | 24   | 24   | 24   | -    | -    |
|      |            |           |                         | 70   | 24   | 22   | 20   | -    | -    |
|      |            |           |                         | 105  | 22   | 20   | 16   | -    | -    |
|      |            |           |                         | 140  | 16   | 14   | 10   | -    | -    |
|      |            | 175       |                         | 9  | 4    | -    | -    | -    |      |
|      |            | 210       | 4                       | -  | -    | -    | -    |      |      |
|      |            | 8         | Horizontal              | 0  | 30   | 30   | 28   | 26   | 24   |
|      |            |           |                         | 70   | 30   | 30   | 28   | 26   | 24   |
|      |            |           |                         | 140  | 30   | 28   | 24   | 22   | 20   |
|      |            |           |                         | 210  | 30   | 22   | 20   | 18   | 16   |
|      |            |           |                         | 280  | 20   | 18   | 16   | 12   | 10   |
|      |            |           |                         | 350  | 14   | 12   | 7    | -    | -    |
|      |            |           | 420                     | 8  | -    | -    | -    | -    |      |
|      |            |           | Vertical                | 0  | 16   | 16   | 14   | -    | -    |
|      |            |           |                         | 70   | 16   | 16   | 14   | -    | -    |
|      |            |           |                         | 140  | 16   | 14   | 10   | -    | -    |
|      |            |           |                         | 210  | 12   | 10   | 8    | -    | -    |
|      |            |           |                         | 280  | 9    | 8    | 6    | -    | -    |
|      |            | 350       |                         | 4  | -    | -    | -    | -    |      |
|      |            | 420       | -                       | -  | -    | -    | -    |      |      |
|      |            | 16        | Horizontal              | 0  | 25   | 25   | 20   | 20   | 18   |
|      |            |           |                         | 140  | 25   | 25   | 20   | 20   | 18   |
|      |            |           |                         | 280  | 22   | 20   | 16   | 16   | 14   |
|      |            |           |                         | 420  | 20   | 16   | 14   | 12   | 8    |
|      |            |           |                         | 560  | 16   | 14   | 10   | 6    | 4    |
|      |            |           |                         | 700  | -    | 8    | 3.5  | -    | -    |
|      |            |           | Vertical                | 0  | 7    | 7    | 7    | -    | -    |
|      |            |           |                         | 140  | 7    | 7    | 7    | -    | -    |
| 280  | 7          |           |                         | 7  | 6    | -    | -    |      |      |
| 420  | 6          |           |                         | 5  | 4    | -    | -    |      |      |
| 560  | 3          |           |                         | 1.5  | 0.5  | -    | -    |      |      |
| 700  | -          |           |                         | -  | -    | -    | -    |      |      |

[When high-output setting for side-mounted motor type is effective]

(Note) If the stroke is long, lighten the transportable mass according to the graph in "1.2.3 Allowable Transportable Mass".

• Standard Specification

| Type | Motor Type | Lead [mm] | Horizontal/<br>Vertical | Transportable Mass by Acceleration/Deceleration [kg] |      |      |      |      |      |
|------|------------|-----------|-------------------------|--|------|------|------|------|------|
|      |            |           |                         | Velocity [mm/s]                                      | 0.1G | 0.3G | 0.5G | 0.7G | 1.0G |
| TA4R | 35P        | 2.5       | Horizontal              | 0  | 5    | 5    | 5    | 5    | 5    |
|      |            |           |                         | 20   | 5    | 5    | 5    | 5    | 5    |
|      |            |           |                         | 40   | 5    | 5    | 5    | 5    | 5    |
|      |            |           |                         | 65   | 5    | 5    | 5    | 5    | 5    |
|      |            |           |                         | 85   | 5    | 5    | 5    | 5    | 5    |
|      |            |           |                         | 105  | 5    | 5    | 5    | 5    | 5    |
|      |            |           |                         | 130  | 5    | 5    | 5    | 5    | 4.5  |
|      |            |           |                         | 150  | 5    | 5    | 5    | 5    | 4    |
|      |            |           |                         | 175  | 5    | 5    | 5    | 4    | 3.5  |
|      |            |           | 195                     | 5  | 5    | 5    | 4    | 3    |      |
|      |            |           | Vertical                | 0  | 10   | 9    | 8    | -    | -    |
|      |            |           |                         | 20   | 10   | 9    | 8    | -    | -    |
|      |            |           |                         | 40   | 10   | 9    | 8    | -    | -    |
|      |            |           |                         | 65   | 10   | 9    | 8    | -    | -    |
|      |            |           |                         | 85   | 10   | 9    | 7    | -    | -    |
|      |            |           |                         | 105  | 10   | 8    | 7    | -    | -    |
|      |            |           |                         | 130  | 10   | 8    | 6    | -    | -    |
|      |            |           |                         | 150  | 9    | 7    | 6    | -    | -    |
|      |            | 175       |                         | 7.5  | 7    | 4.5  | -    | -    |      |
|      |            | 195       | 5                       | 4  | 4    | -    | -    |      |      |
|      |            | 5         | Horizontal              | 0  | 5    | 5    | 5    | 5    | 5    |
|      |            |           |                         | 40   | 5    | 5    | 5    | 5    | 5    |
|      |            |           |                         | 85   | 5    | 5    | 5    | 5    | 5    |
|      |            |           |                         | 130  | 5    | 5    | 5    | 5    | 5    |
|      |            |           |                         | 175  | 5    | 5    | 5    | 5    | 5    |
|      |            |           |                         | 215  | 5    | 5    | 5    | 5    | 5    |
|      |            |           |                         | 260  | 5    | 5    | 5    | 5    | 4.5  |
|      |            |           |                         | 305  | 5    | 5    | 5    | 5    | 4    |
|      |            |           |                         | 350  | 5    | 5    | 5    | 4    | 3.5  |
|      |            |           | 390                     | -  | 5    | 5    | 4    | 3    |      |
|      |            |           | Vertical                | 0  | 5    | 5    | 5    | -    | -    |
|      |            |           |                         | 40   | 5    | 5    | 5    | -    | -    |
|      |            |           |                         | 85   | 5    | 5    | 5    | -    | -    |
|      |            |           |                         | 130  | 5    | 5    | 5    | -    | -    |
|      |            |           |                         | 175  | 5    | 5    | 5    | -    | -    |
|      |            |           |                         | 215  | 5    | 5    | 5    | -    | -    |
| 260  | 5          |           |                         | 5  | 5    | -    | -    |      |      |
| 305  | 4.5        |           |                         | 4.5  | 4.5  | -    | -    |      |      |
| 350  | 4          | 2         |                         | 2  | -    | -    |      |      |      |
| 390  | -          | 1.5       | 1                       | -  | -    |      |      |      |      |

[When high-output setting for side-mounted motor type is effective]

(Note) If the stroke is long, lighten the transportable mass according to the graph in "1.2.3 Allowable Transportable Mass".

• Standard Specification

| Type | Motor Type | Lead [mm] | Horizontal/<br>Vertical | Transportable Mass by Acceleration/Deceleration [kg] |      |      |      |      |      |
|------|------------|-----------|-------------------------|--|------|------|------|------|------|
|      |            |           |                         | Velocity [mm/s]                                      | 0.1G | 0.3G | 0.5G | 0.7G | 1.0G |
| TA4R | 35P        | 10        | Horizontal              | 0  | 4    | 4    | 4    | 4    | 4    |
|      |            |           |                         | 85   | 4    | 4    | 4    | 4    | 4    |
|      |            |           |                         | 175  | 4    | 4    | 4    | 4    | 4    |
|      |            |           |                         | 260  | 4    | 4    | 4    | 4    | 4    |
|      |            |           |                         | 350  | 4    | 4    | 4    | 4    | 4    |
|      |            |           |                         | 435  | -    | 4    | 4    | 4    | 4    |
|      |            |           |                         | 525  | -    | -    | 4    | 4    | 4    |
|      |            |           |                         | 610  | -    | -    | 4    | 4    | 4    |
|      |            |           |                         | 700  | -    | -    | 4    | 4    | 2.5  |
|      |            |           |                         | 785  | -    | -    | -    | 2.5  | 2    |
|      |            |           | 0                       | 2.5  | 2.5  | 2    | -    | -    |      |
|      |            |           | 85                      | 2.5  | 2.5  | 2    | -    | -    |      |
|      |            |           | 175                     | 2.5  | 2.5  | 2    | -    | -    |      |
|      |            |           | 260                     | 2.5  | 2.5  | 2    | -    | -    |      |
|      |            | 350       | 2.5                     | 2.5  | 2    | -    | -    |      |      |
|      |            | 435       | -                       | 2.5  | 2    | -    | -    |      |      |
|      |            | 525       | -                       | -  | 2    | -    | -    |      |      |
|      |            | 610       | -                       | -  | 1.5  | -    | -    |      |      |
|      |            | 700       | -                       | -  | 1    | -    | -    |      |      |
|      |            | 785       | -                       | -  | -    | -    | -    |      |      |
|      |            | 0         | 3                       | 3  | 3    | 3    | 3    |      |      |
|      |            | 140       | 3                       | 3  | 3    | 3    | 3    |      |      |
|      |            | 280       | 3                       | 3  | 3    | 3    | 3    |      |      |
|      |            | 420       | -                       | 3  | 3    | 3    | 3    |      |      |
|      |            | 560       | -                       | 3  | 3    | 3    | 3    |      |      |
|      |            | 700       | -                       | -  | 3    | 3    | 3    |      |      |
|      |            | 840       | -                       | -  | -    | 3    | 2.5  |      |      |
|      |            | 980       | -                       | -  | -    | -    | 1.5  |      |      |
| 1120 | -          | -         | -                       | -  | -    |      |      |      |      |
| 1260 | -          | -         | -                       | -  | -    |      |      |      |      |
| 0    | 1          | 1         | 1                       | -  | -    |      |      |      |      |
| 140  | 1          | 1         | 1                       | -  | -    |      |      |      |      |
| 280  | 1          | 1         | 1                       | -  | -    |      |      |      |      |
| 420  | -          | 1         | 1                       | -  | -    |      |      |      |      |
| 560  | -          | 1         | 1                       | -  | -    |      |      |      |      |
| 700  | -          | -         | 1                       | -  | -    |      |      |      |      |
| 840  | -          | -         | -                       | -  | -    |      |      |      |      |
| 980  | -          | -         | -                       | -  | -    |      |      |      |      |
| 1120 | -          | -         | -                       | -  | -    |      |      |      |      |
| 1260 | -          | -         | -                       | -  | -    |      |      |      |      |

[When high-output setting for side-mounted motor type is effective]

(Note) If the stroke is long, lighten the transportable mass according to the graph in "1.2.3 Allowable Transportable Mass".

• Standard Specification

| Type | Motor Type | Lead [mm] | Horizontal/<br>Vertical | Transportable Mass by Acceleration/Deceleration [kg] |      |      |      |      |      |
|------|------------|-----------|-------------------------|--|------|------|------|------|------|
|      |            |           |                         | Velocity [mm/s]                                      | 0.1G | 0.3G | 0.5G | 0.7G | 1.0G |
| TA6R | 42P        | 3         | Horizontal              | 0  | 10   | 10   | 10   | 8    | 7    |
|      |            |           |                         | 20   | 10   | 10   | 10   | 8    | 7    |
|      |            |           |                         | 50   | 10   | 10   | 10   | 8    | 7    |
|      |            |           |                         | 80   | 10   | 10   | 10   | 8    | 7    |
|      |            |           |                         | 110  | 10   | 10   | 10   | 8    | 7    |
|      |            |           |                         | 125  | 10   | 10   | 10   | 8    | 7    |
|      |            |           |                         | 140  | 10   | 10   | 10   | 8    | 7    |
|      |            |           | 170                     | 10   | 10   | 8    | 7    | 6    |      |
|      |            |           | 200                     | 10   | 8    | 7    | 6    | 4    |      |
|      |            |           | Vertical                | 0  | 12   | 12   | 10   | -    | -    |
|      |            |           |                         | 20   | 12   | 12   | 10   | -    | -    |
|      |            |           |                         | 50   | 12   | 12   | 10   | -    | -    |
|      |            |           |                         | 80   | 12   | 12   | 10   | -    | -    |
|      |            |           |                         | 110  | 12   | 12   | 10   | -    | -    |
|      |            | 125       |                         | 12   | 12   | 10   | -    | -    |      |
|      |            | 140       |                         | 12   | 12   | 10   | -    | -    |      |
|      |            | 170       | 5                       | 5  | 5    | -    | -    |      |      |
|      |            | 200       | 4                       | 4  | 4    | -    | -    |      |      |
|      |            | 6         | Horizontal              | 0  | 10   | 10   | 9    | 8    | 7    |
|      |            |           |                         | 40   | 10   | 10   | 9    | 8    | 7    |
|      |            |           |                         | 100  | 10   | 10   | 9    | 8    | 7    |
|      |            |           |                         | 160  | 10   | 10   | 9    | 8    | 7    |
|      |            |           |                         | 220  | 10   | 10   | 9    | 8    | 7    |
|      |            |           |                         | 250  | 10   | 10   | 9    | 8    | 7    |
|      |            |           |                         | 280  | 10   | 10   | 9    | 8    | 7    |
|      |            |           | 340                     | 10   | 10   | 9    | 8    | 7    |      |
|      |            |           | 400                     | 10   | 9    | 8    | 7    | 6    |      |
|      |            |           | Vertical                | 0  | 6    | 6    | 6    | -    | -    |
| 40   | 6          |           |                         | 6  | 6    | -    | -    |      |      |
| 100  | 6          |           |                         | 6  | 6    | -    | -    |      |      |
| 160  | 6          |           |                         | 6  | 6    | -    | -    |      |      |
| 220  | 6          |           |                         | 6  | 6    | -    | -    |      |      |
| 250  | 6          | 6         |                         | 5.5  | -    | -    |      |      |      |
| 280  | 6          | 5.5       |                         | 5  | -    | -    |      |      |      |
| 340  | 6          | 4.5       | 4                       | -  | -    |      |      |      |      |
| 400  | 4.5        | 3.5       | 3                       | -  | -    |      |      |      |      |

[When high-output setting for side-mounted motor type is effective]

(Note) If the stroke is long, lighten the transportable mass according to the graph in "1.2.3 Allowable Transportable Mass".

• Standard Specification

| Type | Motor Type | Lead [mm] | Horizontal/<br>Vertical | Transportable Mass by Acceleration/Deceleration [kg] |      |      |      |      |      |
|------|------------|-----------|-------------------------|--|------|------|------|------|------|
|      |            |           |                         | Velocity [mm/s]                                      | 0.1G | 0.3G | 0.5G | 0.7G | 1.0G |
| TA6R | 42P        | 12        | Horizontal              | 0  | 8    | 8    | 8    | 7    | 6    |
|      |            |           |                         | 80   | 8    | 8    | 8    | 7    | 6    |
|      |            |           |                         | 200  | 8    | 8    | 8    | 7    | 6    |
|      |            |           |                         | 320  | 8    | 8    | 8    | 7    | 6    |
|      |            |           |                         | 440  | 8    | 8    | 8    | 7    | 6    |
|      |            |           |                         | 500  | -    | 8    | 8    | 7    | 6    |
|      |            |           |                         | 560  | -    | 8    | 8    | 6    | 4    |
|      |            |           |                         | 680  | -    | 8    | 7    | 4    | 2.5  |
|      |            |           | 800                     | -  | -    | 5    | 2    | 1    |      |
|      |            |           | Vertical                | 0  | 3    | 3    | 3    | -    | -    |
|      |            |           |                         | 80   | 3    | 3    | 3    | -    | -    |
|      |            |           |                         | 200  | 3    | 3    | 3    | -    | -    |
|      |            |           |                         | 320  | 3    | 3    | 3    | -    | -    |
|      |            |           |                         | 440  | 3    | 3    | 3    | -    | -    |
|      |            |           |                         | 500  | -    | 3    | 3    | -    | -    |
|      |            |           |                         | 560  | -    | 3    | 2.5  | -    | -    |
|      |            | 680       |                         | -  | 2    | 1.5  | -    | -    |      |
|      |            | 800       | -                       | -  | -    | -    | -    |      |      |
|      |            | 20        | Horizontal              | 0  | 5    | 5    | 5    | 5    | 5    |
|      |            |           |                         | 160  | 5    | 5    | 5    | 5    | 5    |
|      |            |           |                         | 320  | 5    | 5    | 5    | 5    | 5    |
|      |            |           |                         | 480  | -    | 5    | 5    | 5    | 5    |
|      |            |           |                         | 640  | -    | 5    | 5    | 5    | 5    |
|      |            |           |                         | 800  | -    | -    | 5    | 4.5  | 4    |
|      |            |           |                         | 960  | -    | -    | -    | 3.5  | 2    |
|      |            |           |                         | 1120   | -    | -    | -    | -    | 1.5  |
|      |            |           | Vertical                | 0  | 1    | 1    | 1    | -    | -    |
|      |            |           |                         | 160  | 1    | 1    | 1    | -    | -    |
| 320  | 1          |           |                         | 1  | 1    | -    | -    |      |      |
| 480  | -          |           |                         | 1  | 1    | -    | -    |      |      |
| 640  | -          | 1         | 1                       | -  | -    |      |      |      |      |
| 800  | -          | -         | 1                       | -  | -    |      |      |      |      |
| 960  | -          | -         | -                       | -  | -    |      |      |      |      |
| 1120 | -          | -         | -                       | -  | -    |      |      |      |      |

[When high-output setting for side-mounted motor type is effective]

(Note) If the stroke is long, lighten the transportable mass according to the graph in "1.2.3 Allowable Transportable Mass".

• Standard Specification

| Type | Motor Type | Lead [mm] | Horizontal/ Vertical | Transportable Mass by Acceleration/Deceleration [kg] |      |      |      |      |      |
|------|------------|-----------|----------------------|--|------|------|------|------|------|
|      |            |           |                      | Velocity [mm/s]                                      | 0.1G | 0.3G | 0.5G | 0.7G | 1.0G |
| TA7R | 56P        | 4         | Horizontal           | 0  | 15   | 15   | 15   | 15   | 15   |
|      |            |           |                      | 35   | 15   | 15   | 15   | 15   | 15   |
|      |            |           |                      | 70   | 15   | 15   | 15   | 15   | 15   |
|      |            |           |                      | 105  | 15   | 15   | 15   | 15   | 12   |
|      |            |           |                      | 140  | 15   | 15   | 15   | 12   | 10   |
|      |            |           |                      | 175  | 15   | 10   | 4    | -    | -    |
|      |            |           | 210                  | 4  | -    | -    | -    | -    |      |
|      |            |           | Vertical             | 0  | 20   | 20   | 20   | -    | -    |
|      |            |           |                      | 35   | 20   | 20   | 20   | -    | -    |
|      |            |           |                      | 70   | 20   | 18   | 14   | -    | -    |
|      |            |           |                      | 105  | 18   | 16   | 10   | -    | -    |
|      |            |           |                      | 140  | 16   | 12   | 6    | -    | -    |
|      |            | 175       |                      | 7  | 4    | -    | -    | -    |      |
|      |            | 210       | 2                    | -  | -    | -    | -    |      |      |
|      |            | 8         | Horizontal           | 0  | 15   | 15   | 15   | 15   | 15   |
|      |            |           |                      | 70   | 15   | 15   | 15   | 15   | 15   |
|      |            |           |                      | 140  | 15   | 15   | 15   | 15   | 12   |
|      |            |           |                      | 210  | 15   | 15   | 15   | 12   | 10   |
|      |            |           |                      | 280  | 15   | 15   | 12   | 10   | 8    |
|      |            |           |                      | 350  | 12   | 10   | 8    | -    | -    |
|      |            |           | 420                  | 8  | -    | -    | -    | -    |      |
|      |            |           | Vertical             | 0  | 16   | 14   | 12   | -    | -    |
|      |            |           |                      | 70   | 16   | 14   | 12   | -    | -    |
|      |            |           |                      | 140  | 16   | 14   | 10   | -    | -    |
| 210  | 12         |           |                      | 10   | 8    | -    | -    |      |      |
| 280  | 9          |           |                      | 7  | 6    | -    | -    |      |      |
| 350  | 4          | -         |                      | -  | -    | -    |      |      |      |
| 420  | -          | -         | -                    | -  | -    |      |      |      |      |

[When high-output setting for side-mounted motor type is effective]

(Note) If the stroke is long, lighten the transportable mass according to the graph in "1.2.3 Allowable Transportable Mass".

• Standard Specification

| Type | Motor Type | Lead [mm] | Horizontal/ Vertical | Transportable Mass by Acceleration/Deceleration [kg] |      |      |      |      |      |
|------|------------|-----------|----------------------|--|------|------|------|------|------|
|      |            |           |                      | Velocity [mm/s]                                      | 0.1G | 0.3G | 0.5G | 0.7G | 1.0G |
| TA7R | 56P        | 16        | Horizontal           | 0  | 12   | 12   | 12   | 10   | 10   |
|      |            |           |                      | 140  | 12   | 12   | 12   | 10   | 10   |
|      |            |           |                      | 280  | 12   | 12   | 12   | 10   | 10   |
|      |            |           |                      | 420  | 12   | 12   | 12   | 10   | 8    |
|      |            |           |                      | 560  | -    | 12   | 10   | 7    | 5    |
|      |            |           | 700                  | -  | 9    | 4    | 1    | -    |      |
|      |            |           | Vertical             | 0  | 7    | 7    | 7    | -    | -    |
|      |            |           |                      | 140  | 7    | 7    | 7    | -    | -    |
|      |            |           |                      | 280  | 7    | 7    | 6    | -    | -    |
|      |            |           |                      | 420  | 6    | 5    | 4    | -    | -    |
|      |            | 560       |                      | -  | 3    | 1.5  | -    | -    |      |
|      |            | 700       | -                    | -  | -    | -    | -    |      |      |
|      |            | 24        | Horizontal           | 0  | 10   | 10   | 10   | 8    | 8    |
|      |            |           |                      | 200  | 10   | 10   | 10   | 8    | 8    |
|      |            |           |                      | 420  | 10   | 10   | 10   | 8    | 8    |
|      |            |           |                      | 640  | -    | 10   | 10   | 7    | 6    |
|      |            |           |                      | 860  | -    | 7    | 5    | 4    | 2    |
|      |            |           | 1080                 | -  | -    | 2    | 0.5  | -    |      |
|      |            |           | Vertical             | 0  | 3    | 3    | 3    | -    | -    |
|      |            |           |                      | 200  | 3    | 3    | 3    | -    | -    |
| 420  | 3          |           |                      | 3  | 3    | -    | -    |      |      |
| 640  | -          |           |                      | 3  | 2.5  | -    | -    |      |      |
| 860  | -          | 1         |                      | 0.5  | -    | -    |      |      |      |
| 1080 | -          | -         | -                    | -  | -    |      |      |      |      |

[When high-output setting for side-mounted motor type is effective]

(Note) If the stroke is long, lighten the transportable mass according to the graph in "1.2.3 Allowable Transportable Mass".

• Double Guide Block (Option Model: DB)

| Type | Motor Type | Lead [mm] | Horizontal/<br>Vertical | Transportable Mass by Acceleration/Deceleration [kg] |      |      |      |      |      |
|------|------------|-----------|-------------------------|--|------|------|------|------|------|
|      |            |           |                         | Velocity [mm/s]                                      | 0.1G | 0.3G | 0.5G | 0.7G | 1.0G |
| TA4R | 35P        | 2.5       | Horizontal              | 0  | 10   | 10   | 9    | 8    | 6    |
|      |            |           |                         | 20   | 10   | 10   | 9    | 8    | 6    |
|      |            |           |                         | 40   | 10   | 10   | 9    | 8    | 6    |
|      |            |           |                         | 65   | 10   | 9    | 9    | 8    | 6    |
|      |            |           |                         | 85   | 10   | 9    | 8    | 6    | 6    |
|      |            |           |                         | 105  | 10   | 9    | 8    | 6    | 5    |
|      |            |           |                         | 130  | 9    | 8    | 7    | 5    | 4.5  |
|      |            |           |                         | 150  | 9    | 8    | 6    | 5    | 4    |
|      |            |           |                         | 175  | 8    | 7    | 6    | 4    | 3.5  |
|      |            |           | 195                     | 8  | 7    | 6    | 4    | 3    |      |
|      |            |           | Vertical                | 0  | 10   | 9    | 8    | -    | -    |
|      |            |           |                         | 20   | 10   | 9    | 8    | -    | -    |
|      |            |           |                         | 40   | 10   | 9    | 8    | -    | -    |
|      |            |           |                         | 65   | 10   | 9    | 8    | -    | -    |
|      |            |           |                         | 85   | 10   | 9    | 7    | -    | -    |
|      |            |           |                         | 105  | 10   | 8    | 7    | -    | -    |
|      |            |           |                         | 130  | 10   | 8    | 6    | -    | -    |
|      |            |           |                         | 150  | 9    | 7    | 6    | -    | -    |
|      |            | 175       |                         | 5  | 5    | 4.5  | -    | -    |      |
|      |            | 195       | 4.5                     | 4  | 4    | -    | -    |      |      |
|      |            | 5         | Horizontal              | 0  | 10   | 10   | 9    | 8    | 6    |
|      |            |           |                         | 40   | 10   | 10   | 9    | 8    | 6    |
|      |            |           |                         | 85   | 10   | 10   | 9    | 8    | 6    |
|      |            |           |                         | 130  | 10   | 9    | 9    | 8    | 6    |
|      |            |           |                         | 175  | 10   | 9    | 8    | 6    | 6    |
|      |            |           |                         | 215  | 10   | 9    | 8    | 6    | 5    |
|      |            |           |                         | 260  | 9    | 8    | 7    | 5    | 4.5  |
|      |            |           |                         | 305  | 9    | 8    | 6    | 5    | 4    |
|      |            |           |                         | 350  | 8    | 7    | 6    | 4    | 3.5  |
|      |            |           | 390                     | -  | 7    | 6    | 3.5  | 3    |      |
|      |            |           | Vertical                | 0  | 5    | 5    | 5    | -    | -    |
|      |            |           |                         | 40   | 5    | 5    | 5    | -    | -    |
|      |            |           |                         | 85   | 5    | 5    | 5    | -    | -    |
|      |            |           |                         | 130  | 5    | 5    | 5    | -    | -    |
|      |            |           |                         | 175  | 5    | 5    | 5    | -    | -    |
|      |            |           |                         | 215  | 5    | 5    | 5    | -    | -    |
| 260  | 5          |           |                         | 5  | 5    | -    | -    |      |      |
| 305  | 4          |           |                         | 4  | 4    | -    | -    |      |      |
| 350  | 3.5        | 3         |                         | 3  | -    | -    |      |      |      |
| 390  | -          | 2         | 2                       | -  | -    |      |      |      |      |

[When high-output setting for side-mounted motor type is effective]

(Note) If the stroke is long, lighten the transportable mass according to the graph in "1.2.3 Allowable Transportable Mass".

• Double Guide Block (Option Model: DB)

| Type | Motor Type | Lead [mm] | Horizontal/<br>Vertical | Transportable Mass by Acceleration/Deceleration [kg] |      |      |      |      |      |
|------|------------|-----------|-------------------------|--|------|------|------|------|------|
|      |            |           |                         | Velocity [mm/s]                                      | 0.1G | 0.3G | 0.5G | 0.7G | 1.0G |
| TA4R | 35P        | 10        | Horizontal              | 0  | 8    | 8    | 8    | 8    | 6    |
|      |            |           |                         | 85   | 8    | 8    | 8    | 8    | 6    |
|      |            |           |                         | 175  | 8    | 8    | 8    | 8    | 6    |
|      |            |           |                         | 260  | 8    | 8    | 8    | 8    | 6    |
|      |            |           |                         | 350  | 8    | 8    | 8    | 6    | 6    |
|      |            |           |                         | 435  | -    | 8    | 8    | 6    | 5    |
|      |            |           |                         | 525  | -    | -    | 8    | 5    | 4.5  |
|      |            |           |                         | 610  | -    | -    | 5    | 4    | 3.5  |
|      |            |           |                         | 700  | -    | -    | 3.5  | 2.5  | 2    |
|      |            |           | Vertical                | 0  | 2.5  | 2.5  | 2    | -    | -    |
|      |            |           |                         | 85   | 2.5  | 2.5  | 2    | -    | -    |
|      |            |           |                         | 175  | 2.5  | 2.5  | 2    | -    | -    |
|      |            |           |                         | 260  | 2.5  | 2.5  | 2    | -    | -    |
|      |            |           |                         | 350  | 2.5  | 2.5  | 2    | -    | -    |
|      |            |           |                         | 435  | -    | 2.5  | 2    | -    | -    |
|      |            |           |                         | 525  | -    | -    | 1.5  | -    | -    |
| 610  | -          | -         | -                       | -  | -    |      |      |      |      |
| 700  | -          | -         | -                       | -  | -    |      |      |      |      |

[When high-output setting for side-mounted motor type is effective]

(Note) If the stroke is long, lighten the transportable mass according to the graph in "1.2.3 Allowable Transportable Mass".

• Double Guide Block (Option Model: DB)

| Type | Motor Type | Lead [mm] | Horizontal/<br>Vertical | Transportable Mass by Acceleration/Deceleration [kg] |      |      |      |      |      |
|------|------------|-----------|-------------------------|--|------|------|------|------|------|
|      |            |           |                         | Velocity [mm/s]                                      | 0.1G | 0.3G | 0.5G | 0.7G | 1.0G |
| TA6R | 42P        | 3         | Horizontal              | 0  | 20   | 20   | 18   | 16   | 15   |
|      |            |           |                         | 20   | 20   | 20   | 18   | 16   | 15   |
|      |            |           |                         | 50   | 20   | 20   | 18   | 16   | 15   |
|      |            |           |                         | 80   | 20   | 20   | 18   | 16   | 15   |
|      |            |           |                         | 110  | 20   | 20   | 18   | 16   | 15   |
|      |            |           |                         | 125  | 20   | 20   | 18   | 16   | 15   |
|      |            |           |                         | 140  | 20   | 20   | 18   | 16   | 15   |
|      |            |           | 170                     | 20   | 18   | 16   | 14   | 12   |      |
|      |            |           | 200                     | 18   | 16   | 14   | 12   | 10   |      |
|      |            |           | Vertical                | 0  | 12   | 12   | 10   | -    | -    |
|      |            |           |                         | 20   | 12   | 12   | 10   | -    | -    |
|      |            |           |                         | 50   | 12   | 12   | 10   | -    | -    |
|      |            |           |                         | 80   | 12   | 12   | 10   | -    | -    |
|      |            |           |                         | 110  | 12   | 12   | 10   | -    | -    |
|      |            | 125       |                         | 12   | 12   | 10   | -    | -    |      |
|      |            | 140       |                         | 12   | 12   | 10   | -    | -    |      |
|      |            | 170       | 12                      | 9  | 8    | -    | -    |      |      |
|      |            | 200       | 8                       | 7  | 7    | -    | -    |      |      |
|      |            | 6         | Horizontal              | 0  | 20   | 20   | 18   | 16   | 14   |
|      |            |           |                         | 40   | 20   | 20   | 18   | 16   | 14   |
|      |            |           |                         | 100  | 20   | 20   | 18   | 16   | 14   |
|      |            |           |                         | 160  | 20   | 20   | 18   | 16   | 14   |
|      |            |           |                         | 220  | 20   | 20   | 18   | 16   | 14   |
|      |            |           |                         | 250  | 20   | 20   | 18   | 16   | 14   |
|      |            |           |                         | 280  | 20   | 18   | 16   | 15   | 11   |
|      |            |           | 340                     | 20   | 16   | 14   | 12   | 9    |      |
|      |            |           | 400                     | 18   | 14   | 10   | 8    | 6    |      |
|      |            |           | Vertical                | 0  | 6    | 6    | 6    | -    | -    |
| 40   | 6          |           |                         | 6  | 6    | -    | -    |      |      |
| 100  | 6          |           |                         | 6  | 6    | -    | -    |      |      |
| 160  | 6          |           |                         | 6  | 6    | -    | -    |      |      |
| 220  | 6          |           |                         | 6  | 6    | -    | -    |      |      |
| 250  | 6          | 6         |                         | 5.5  | -    | -    |      |      |      |
| 280  | 6          | 5.5       |                         | 5  | -    | -    |      |      |      |
| 340  | 6          | 4.5       | 4                       | -  | -    |      |      |      |      |
| 400  | 4          | 2         | 1.5                     | -  | -    |      |      |      |      |

[When high-output setting for side-mounted motor type is effective]

(Note) If the stroke is long, lighten the transportable mass according to the graph in "1.2.3 Allowable Transportable Mass".

• Double Guide Block (Option Model: DB)

| Type | Motor Type | Lead [mm] | Horizontal/<br>Vertical | Transportable Mass by Acceleration/Deceleration [kg] |      |      |      |      |      |
|------|------------|-----------|-------------------------|--|------|------|------|------|------|
|      |            |           |                         | Velocity [mm/s]                                      | 0.1G | 0.3G | 0.5G | 0.7G | 1.0G |
| TA6R | 42P        | 12        | Horizontal              | 0  | 15   | 15   | 12   | 11   | 10   |
|      |            |           |                         | 80   | 15   | 15   | 12   | 11   | 10   |
|      |            |           |                         | 200  | 15   | 15   | 12   | 11   | 10   |
|      |            |           |                         | 320  | 15   | 15   | 12   | 11   | 10   |
|      |            |           |                         | 440  | 15   | 14   | 11   | 10   | 8    |
|      |            |           |                         | 500  | -    | 13   | 10   | 8    | 6    |
|      |            |           |                         | 560  | -    | 12   | 9    | 6    | 3    |
|      |            |           |                         | 680  | -    | 10   | 6    | 3    | 1.5  |
|      |            |           | 800                     | -  | -    | 4    | 1    | -    |      |
|      |            |           | Vertical                | 0  | 3    | 3    | 3    | -    | -    |
|      |            |           |                         | 80   | 3    | 3    | 3    | -    | -    |
|      |            |           |                         | 200  | 3    | 3    | 3    | -    | -    |
|      |            |           |                         | 320  | 3    | 3    | 3    | -    | -    |
|      |            |           |                         | 440  | 3    | 3    | 3    | -    | -    |
|      |            |           |                         | 500  | -    | 3    | 3    | -    | -    |
|      |            |           |                         | 560  | -    | 3    | 2.5  | -    | -    |
| 680  | -          | 1.5       |                         | 1  | -    | -    |      |      |      |
| 800  | -          | -         | -                       | -  | -    |      |      |      |      |

[When high-output setting for side-mounted motor type is effective]

(Note) If the stroke is long, lighten the transportable mass according to the graph in "1.2.3 Allowable Transportable Mass".

• Double Guide Block (Option Model: DB)

| Type | Motor Type | Lead [mm] | Horizontal/<br>Vertical | Transportable Mass by Acceleration/Deceleration [kg] |      |      |      |      |      |
|------|------------|-----------|-------------------------|--|------|------|------|------|------|
|      |            |           |                         | Velocity [mm/s]                                      | 0.1G | 0.3G | 0.5G | 0.7G | 1.0G |
| TA7R | 56P        | 4         | Horizontal              | 0  | 30   | 30   | 28   | 26   | 24   |
|      |            |           |                         | 35   | 30   | 30   | 28   | 26   | 24   |
|      |            |           |                         | 70   | 30   | 28   | 24   | 22   | 20   |
|      |            |           |                         | 105  | 25   | 22   | 20   | 18   | 16   |
|      |            |           |                         | 140  | 20   | 18   | 16   | 12   | 10   |
|      |            |           |                         | 175  | 14   | 10   | 5    | -    | -    |
|      |            |           | 210                     | 6  | -    | -    | -    | -    |      |
|      |            |           | Vertical                | 0  | 24   | 24   | 24   | -    | -    |
|      |            |           |                         | 35   | 24   | 24   | 24   | -    | -    |
|      |            |           |                         | 70   | 24   | 22   | 20   | -    | -    |
|      |            |           |                         | 105  | 22   | 20   | 16   | -    | -    |
|      |            |           |                         | 140  | 16   | 14   | 10   | -    | -    |
|      |            | 175       |                         | 8  | 3    | -    | -    | -    |      |
|      |            | 210       | 3                       | -  | -    | -    | -    |      |      |
|      |            | 8         | Horizontal              | 0  | 30   | 30   | 28   | 26   | 24   |
|      |            |           |                         | 70   | 30   | 30   | 28   | 26   | 24   |
|      |            |           |                         | 140  | 30   | 28   | 24   | 22   | 20   |
|      |            |           |                         | 210  | 30   | 22   | 20   | 18   | 16   |
|      |            |           |                         | 280  | 20   | 18   | 16   | 12   | 10   |
|      |            |           |                         | 350  | 14   | 12   | 6    | -    | -    |
|      |            |           | 420                     | 6  | -    | -    | -    | -    |      |
|      |            |           | Vertical                | 0  | 16   | 16   | 14   | -    | -    |
|      |            |           |                         | 70   | 16   | 16   | 14   | -    | -    |
|      |            |           |                         | 140  | 16   | 14   | 10   | -    | -    |
|      |            |           |                         | 210  | 12   | 10   | 8    | -    | -    |
|      |            |           |                         | 280  | 9    | 5.5  | 4.5  | -    | -    |
|      |            | 350       |                         | 3  | -    | -    | -    | -    |      |
|      |            | 420       | -                       | -  | -    | -    | -    |      |      |
|      |            | 16        | Horizontal              | 0  | 25   | 25   | 20   | 20   | 18   |
|      |            |           |                         | 140  | 25   | 25   | 20   | 20   | 18   |
|      |            |           |                         | 280  | 22   | 20   | 16   | 16   | 14   |
|      |            |           |                         | 420  | 20   | 16   | 14   | 12   | 8    |
|      |            |           |                         | 560  | 16   | 14   | 10   | 6    | 3    |
|      |            |           |                         | 700  | -    | 8    | 3    | -    | -    |
|      |            |           | Vertical                | 0  | 7    | 7    | 7    | -    | -    |
|      |            |           |                         | 140  | 7    | 7    | 7    | -    | -    |
| 280  | 7          |           |                         | 7  | 6    | -    | -    |      |      |
| 420  | 5          |           |                         | 4  | 3    | -    | -    |      |      |
| 560  | 3          |           |                         | 1  | -    | -    | -    |      |      |
| 700  | -          |           |                         | -  | -    | -    | -    |      |      |

 **Caution:** Do not attempt to establish the settings for the acceleration/deceleration above the allowable range. It may cause a vibration, malfunction or shorten the product life. If any acceleration/deceleration equal to or greater than the rated acceleration/deceleration is set, a creep phenomenon or slipped coupling may occur.

[When high-output setting for motor straight type is ineffective]

(Note) If the stroke is long, lighten the payload according to the graph in "1.2.3 Allowable Payload".

• Standard Specification

| Type     | Motor Type | Lead [mm] | Horizontal/<br>Vertical | Payload by<br>Acceleration/Deceleration<br>[kg] |      |      |
|----------|------------|-----------|-------------------------|---|------|------|
|          |            |           |                         | Velocity<br>[mm/s]                              | 0.3G | 0.7G |
| TA4C     | 35P        | 2.5       | Horizontal              | 0   | 5    | 5    |
|          |            |           |                         | 20  | 5    | 5    |
|          |            |           |                         | 40  | 5    | 5    |
|          |            |           |                         | 65  | 5    | 5    |
|          |            |           |                         | 85  | 5    | 5    |
|          |            |           |                         | 105   | 5    | 5    |
|          |            |           | Vertical                | 130   | 5    | 5    |
|          |            |           |                         | 0   | 9    | —    |
|          |            |           |                         | 20  | 9    | —    |
|          |            |           |                         | 40  | 9    | —    |
|          |            |           |                         | 65  | 9    | —    |
|          |            |           |                         | 85  | 7.5  | —    |
|          |            | 5         | Horizontal              | 105   | 6    | —    |
|          |            |           |                         | 130   | 4    | —    |
|          |            |           |                         | 0   | 5    | 5    |
|          |            |           |                         | 40  | 5    | 5    |
|          |            |           |                         | 85  | 5    | 5    |
|          |            |           |                         | 130   | 5    | 5    |
|          |            |           | Vertical                | 175   | 5    | 5    |
|          |            |           |                         | 215   | 5    | 5    |
|          |            |           |                         | 260   | 5    | 5    |
|          |            |           |                         | 0   | 5    | —    |
|          |            |           |                         | 40  | 5    | —    |
|          |            |           |                         | 85  | 5    | —    |
| Vertical | 130        | 5         | —                       |   |      |      |
|          | 175        | 4.5       | —                       |   |      |      |
|          | 215        | 4         | —                       |   |      |      |
|          | 260        | 2.5       | —                       |   |      |      |

[When high-output setting for motor straight type is ineffective]

(Note) If the stroke is long, lighten the payload according to the graph in "1.2.3 Allowable Payload".

• Standard Specification

| Type | Motor Type | Lead [mm] | Horizontal/<br>Vertical | Payload by<br>Acceleration/Deceleration<br>[kg] |      |      |
|------|------------|-----------|-------------------------|---|------|------|
|      |            |           |                         | Velocity<br>[mm/s]                              | 0.3G | 0.7G |
| TA4C | 35P        | 10        | Horizontal              | 0   | 4    | 4    |
|      |            |           |                         | 85  | 4    | 4    |
|      |            |           |                         | 175   | 4    | 4    |
|      |            |           |                         | 260   | 4    | 4    |
|      |            |           |                         | 350   | 4    | 4    |
|      |            |           |                         | 435   | 4    | 3.5  |
|      |            |           | 525                     | —   | 2    |      |
|      |            |           | Vertical                | 0   | 2.5  | —    |
|      |            |           |                         | 85  | 2.5  | —    |
|      |            |           |                         | 175   | 2.5  | —    |
|      |            |           |                         | 260   | 2.25 | —    |
|      |            |           |                         | 350   | 1.5  | —    |
|      |            | 435       |                         | 1   | —    |      |
|      |            | 16        | Horizontal              | 0   | 3    | 3    |
|      |            |           |                         | 140   | 3    | 3    |
|      |            |           |                         | 280   | 3    | 3    |
|      |            |           |                         | 420   | 3    | 3    |
|      |            |           |                         | 560   | 2.5  | 2    |
|      |            |           |                         | 700   | —    | 1.5  |
|      |            |           | Vertical                | 840   | —    | 1    |
|      |            |           |                         | 0   | 1    | —    |
|      |            |           |                         | 140   | 1    | —    |
|      |            |           |                         | 280   | 1    | —    |
|      |            |           |                         | 420   | 1    | —    |
| 560  | 0.75       |           |                         | —   |      |      |
| 700  | —          | —         |                         |   |      |      |
| 840  | —          | —         |                         |   |      |      |

[When high-output setting for motor straight type is ineffective]

(Note) If the stroke is long, lighten the payload according to the graph in "1.2.3 Allowable Payload".

• Standard Specification

| Type | Motor Type | Lead [mm] | Horizontal/<br>Vertical | Payload by<br>Acceleration/Deceleration<br>[kg] |      |      |
|------|------------|-----------|-------------------------|---|------|------|
|      |            |           |                         | Velocity<br>[mm/s]                              | 0.3G | 0.7G |
| TA6C | 42P        | 3         | Horizontal              | 0   | 10   | 8    |
|      |            |           |                         | 20  | 10   | 8    |
|      |            |           |                         | 50  | 10   | 8    |
|      |            |           |                         | 80  | 10   | 8    |
|      |            |           |                         | 110   | 10   | 8    |
|      |            |           |                         | 125   | 9    | 8    |
|      |            |           |                         | 140   | 8    | 8    |
|      |            |           | 170                     | 7   | 6    |      |
|      |            |           | Vertical                | 0   | 12   | —    |
|      |            |           |                         | 20  | 12   | —    |
|      |            |           |                         | 50  | 12   | —    |
|      |            |           |                         | 80  | 12   | —    |
|      |            |           |                         | 110   | 9    | —    |
|      |            |           |                         | 125   | 7    | —    |
|      |            | 140       |                         | 5   | —    |      |
|      |            | 170       | —                       | —   |      |      |
|      |            | 6         | Horizontal              | 0   | 10   | 8    |
|      |            |           |                         | 40  | 10   | 8    |
|      |            |           |                         | 100   | 10   | 8    |
|      |            |           |                         | 160   | 10   | 8    |
|      |            |           |                         | 220   | 10   | 8    |
|      |            |           |                         | 250   | 9    | 8    |
|      |            |           |                         | 280   | 8    | 8    |
|      |            |           | 340                     | 6   | 3    |      |
|      |            |           | Vertical                | 0   | 6    | —    |
|      |            |           |                         | 40  | 6    | —    |
|      |            |           |                         | 100   | 6    | —    |
|      |            |           |                         | 160   | 6    | —    |
| 220  | 4          |           |                         | —   |      |      |
| 250  | 3          |           |                         | —   |      |      |
| 280  | 2          | —         |                         |   |      |      |
| 340  | —          | —         |                         |   |      |      |

[When high-output setting for motor straight type is ineffective]

(Note) If the stroke is long, lighten the payload according to the graph in "1.2.3 Allowable Payload".

• Standard Specification

| Type | Motor Type | Lead [mm] | Horizontal/<br>Vertical | Payload by<br>Acceleration/Deceleration<br>[kg] |      |      |
|------|------------|-----------|-------------------------|---|------|------|
|      |            |           |                         | Velocity<br>[mm/s]                              | 0.3G | 0.7G |
| TA6C | 42P        | 12        | Horizontal              | 0   | 8    | 7    |
|      |            |           |                         | 80  | 8    | 7    |
|      |            |           |                         | 200   | 8    | 7    |
|      |            |           |                         | 320   | 8    | 7    |
|      |            |           |                         | 440   | 7    | 6    |
|      |            |           |                         | 500   | 6.5  | 4.5  |
|      |            |           | 560                     | 6   | 3    |      |
|      |            |           | 680                     | 3   | 1    |      |
|      |            |           | Vertical                | 0   | 3    | —    |
|      |            |           |                         | 80  | 3    | —    |
|      |            |           |                         | 200   | 3    | —    |
|      |            |           |                         | 320   | 3    | —    |
|      |            | 440       |                         | 2   | —    |      |
|      |            | 500       |                         | 1.5   | —    |      |
|      |            | 20        | Horizontal              | 560   | 1    | —    |
|      |            |           |                         | 680   | —    | —    |
|      |            |           |                         | 0   | 5    | 5    |
|      |            |           |                         | 160   | 5    | 5    |
|      |            |           |                         | 320   | 4.5  | 4.5  |
|      |            |           |                         | 480   | 4    | 4    |
|      |            |           | Vertical                | 640   | 3    | 3    |
|      |            |           |                         | 800   | —    | 2    |
|      |            |           |                         | 0   | 1    | —    |
|      |            |           |                         | 160   | 1    | —    |
| 320  | 1          |           |                         | —   |      |      |
| 480  | 1          |           |                         | —   |      |      |
| 640  | 0.75       | —         |                         |   |      |      |
| 800  | —          | —         |                         |   |      |      |

[When high-output setting for motor straight type is ineffective]

(Note) If the stroke is long, lighten the payload according to the graph in "1.2.3 Allowable Payload".

• Standard Specification

| Type | Motor Type | Lead [mm] | Horizontal/<br>Vertical | Payload by<br>Acceleration/Deceleration<br>[kg] |      |      |
|------|------------|-----------|-------------------------|---|------|------|
|      |            |           |                         | Velocity<br>[mm/s]                              | 0.3G | 0.7G |
| TA7C | 56P        | 4         | Horizontal              | 0   | 15   | 15   |
|      |            |           |                         | 35  | 15   | 15   |
|      |            |           |                         | 70  | 15   | 15   |
|      |            |           |                         | 105   | 15   | 13   |
|      |            |           | 140                     | 6   | —    |      |
|      |            |           | Vertical                | 0   | 20   | —    |
|      |            |           |                         | 35  | 20   | —    |
|      |            |           |                         | 70  | 18   | —    |
|      |            | 105       |                         | 10  | —    |      |
|      |            | 8         | Horizontal              | 140   | —    | —    |
|      |            |           |                         | 0   | 15   | 15   |
|      |            |           |                         | 70  | 15   | 15   |
|      |            |           |                         | 140   | 15   | 15   |
|      |            |           | 210                     | 15  | 12   |      |
|      |            |           | 280                     | 10  | —    |      |
|      |            |           | Vertical                | 0   | 12   | —    |
| 70   | 12         |           |                         | —   |      |      |
| 140  | 12         | —         |                         |   |      |      |
| 210  | 3.5        | —         |                         |   |      |      |
| 280  | —          | —         |                         |   |      |      |

[When high-output setting for motor straight type is ineffective]

(Note) If the stroke is long, lighten the payload according to the graph in "1.2.3 Allowable Payload".

• Standard Specification

| Type | Motor Type | Lead [mm] | Horizontal/<br>Vertical | Payload by<br>Acceleration/Deceleration<br>[kg] |      |      |
|------|------------|-----------|-------------------------|---|------|------|
|      |            |           |                         | Velocity<br>[mm/s]                              | 0.3G | 0.7G |
| TA7C | 56P        | 16        | Horizontal              | 0   | 12   | 10   |
|      |            |           |                         | 140   | 12   | 10   |
|      |            |           |                         | 280   | 12   | 10   |
|      |            |           |                         | 420   | 12   | 4    |
|      |            |           |                         | 560   | 5    | —    |
|      |            |           | Vertical                | 0   | 5    | —    |
|      |            |           |                         | 140   | 5    | —    |
|      |            |           |                         | 280   | 5    | —    |
|      |            |           |                         | 420   | —    | —    |
|      |            |           |                         | 560   | —    | —    |
|      |            | 24        | Horizontal              | 0   | 10   | 8    |
|      |            |           |                         | 200   | 10   | 8    |
|      |            |           |                         | 420   | 10   | 8    |
|      |            |           |                         | 640   | 5    | 1    |
|      |            |           |                         | 860   | 1    | —    |
|      |            |           | Vertical                | 0   | 3    | —    |
|      |            |           |                         | 200   | 3    | —    |
|      |            |           |                         | 420   | 3    | —    |
|      |            |           | 640                     | —   | —    |      |
|      |            |           | 860                     | —   | —    |      |

[When high-output setting for motor straight type is ineffective]

(Note) If the stroke is long, lighten the payload according to the graph in "1.2.3 Allowable Payload".

• Double Guide Block (Option Model: DB)

| Type     | Motor Type | Lead [mm] | Horizontal/<br>Vertical | Payload by<br>Acceleration/Deceleration<br>[kg] |      |      |
|----------|------------|-----------|-------------------------|---|------|------|
|          |            |           |                         | Velocity<br>[mm/s]                              | 0.3G | 0.7G |
| TA4C     | 35P        | 2.5       | Horizontal              | 0   | 10   | 8    |
|          |            |           |                         | 20  | 10   | 8    |
|          |            |           |                         | 40  | 10   | 8    |
|          |            |           |                         | 65  | 9    | 8    |
|          |            |           |                         | 85  | 9    | 6    |
|          |            |           |                         | 105   | 9    | 6    |
|          |            |           | Vertical                | 130   | 8    | 5    |
|          |            |           |                         | 0   | 9    | —    |
|          |            |           |                         | 20  | 9    | —    |
|          |            |           |                         | 40  | 9    | —    |
|          |            |           |                         | 65  | 9    | —    |
|          |            |           |                         | 85  | 7.5  | —    |
|          |            | 5         | Horizontal              | 105   | 6    | —    |
|          |            |           |                         | 130   | 4    | —    |
|          |            |           |                         | 0   | 10   | 8    |
|          |            |           |                         | 40  | 10   | 8    |
|          |            |           |                         | 85  | 10   | 8    |
|          |            |           |                         | 130   | 9    | 8    |
|          |            |           | Vertical                | 175   | 9    | 6    |
|          |            |           |                         | 215   | 9    | 6    |
|          |            |           |                         | 260   | 8    | 5    |
|          |            |           |                         | 0   | 5    | —    |
|          |            |           |                         | 40  | 5    | —    |
|          |            |           |                         | 85  | 5    | —    |
| Vertical | 130        | 5         | —                       |   |      |      |
|          | 175        | 4.5       | —                       |   |      |      |
|          | 215        | 4         | —                       |   |      |      |
|          | 260        | 2.5       | —                       |   |      |      |

[When high-output setting for motor straight type is ineffective]

(Note) If the stroke is long, lighten the payload according to the graph in "1.2.3 Allowable Payload".

• Double Guide Block (Option Model: DB)

| Type | Motor Type | Lead [mm] | Horizontal/<br>Vertical | Payload by<br>Acceleration/Deceleration<br>[kg] |      |      |
|------|------------|-----------|-------------------------|---|------|------|
|      |            |           |                         | Velocity<br>[mm/s]                              | 0.3G | 0.7G |
| TA4C | 35P        | 10        | Horizontal              | 0   | 8    | 6    |
|      |            |           |                         | 85  | 8    | 6    |
|      |            |           |                         | 175   | 8    | 6    |
|      |            |           |                         | 260   | 8    | 6    |
|      |            |           |                         | 350   | 7    | 5    |
|      |            |           |                         | 435   | 5    | 3.5  |
|      |            |           |                         | 525   | —    | 1.5  |
|      |            |           | Vertical                | 0   | 2.5  | —    |
|      |            |           |                         | 85  | 2.5  | —    |
|      |            |           |                         | 175   | 2.5  | —    |
|      |            |           |                         | 260   | 2.25 | —    |
|      |            |           |                         | 350   | 1.5  | —    |
|      |            |           |                         | 435   | 1    | —    |
|      |            |           |                         | 525   | —    | —    |

[When high-output setting for motor straight type is ineffective]

(Note) If the stroke is long, lighten the payload according to the graph in "1.2.3 Allowable Payload".

• Double Guide Block (Option Model: DB)

| Type | Motor Type | Lead [mm] | Horizontal/<br>Vertical | Payload by<br>Acceleration/Deceleration<br>[kg] |      |      |
|------|------------|-----------|-------------------------|---|------|------|
|      |            |           |                         | Velocity<br>[mm/s]                              | 0.3G | 0.7G |
| TA6C | 42P        | 3         | Horizontal              | 0   | 20   | 16   |
|      |            |           |                         | 20  | 20   | 16   |
|      |            |           |                         | 50  | 20   | 16   |
|      |            |           |                         | 80  | 20   | 16   |
|      |            |           |                         | 110   | 20   | 16   |
|      |            |           |                         | 125   | 18   | 15   |
|      |            |           |                         | 140   | 15   | 14   |
|      |            |           | 170                     | 10  | 7    |      |
|      |            |           | Vertical                | 0   | 12   | —    |
|      |            |           |                         | 20  | 12   | —    |
|      |            |           |                         | 50  | 12   | —    |
|      |            |           |                         | 80  | 12   | —    |
|      |            |           |                         | 110   | 9    | —    |
|      |            |           |                         | 125   | 7    | —    |
|      |            | 140       |                         | 5   | —    |      |
|      |            | 170       | —                       | —   |      |      |
|      |            | 6         | Horizontal              | 0   | 20   | 16   |
|      |            |           |                         | 40  | 20   | 16   |
|      |            |           |                         | 100   | 20   | 16   |
|      |            |           |                         | 160   | 20   | 16   |
|      |            |           |                         | 220   | 20   | 16   |
|      |            |           |                         | 250   | 17   | 12   |
|      |            |           |                         | 280   | 14   | 8    |
|      |            |           | 340                     | 5   | 3    |      |
|      |            |           | Vertical                | 0   | 6    | —    |
|      |            |           |                         | 40  | 6    | —    |
|      |            |           |                         | 100   | 6    | —    |
|      |            |           |                         | 160   | 6    | —    |
| 220  | 4          |           |                         | —   |      |      |
| 250  | 3          |           |                         | —   |      |      |
| 280  | 2          | —         |                         |   |      |      |
| 340  | —          | —         |                         |   |      |      |

[When high-output setting for motor straight type is ineffective]

(Note) If the stroke is long, lighten the payload according to the graph in "1.2.3 Allowable Payload".

• Double Guide Block (Option Model: DB)

| Type | Motor Type | Lead [mm] | Horizontal/<br>Vertical | Payload by<br>Acceleration/Deceleration<br>[kg] |      |      |
|------|------------|-----------|-------------------------|---|------|------|
|      |            |           |                         | Velocity<br>[mm/s]                              | 0.3G | 0.7G |
| TA6C | 42P        | 12        | Horizontal              | 0   | 15   | 11   |
|      |            |           |                         | 80  | 15   | 11   |
|      |            |           |                         | 200   | 15   | 11   |
|      |            |           |                         | 320   | 15   | 10   |
|      |            |           |                         | 440   | 9    | 5    |
|      |            |           |                         | 500   | 6    | 3    |
|      |            |           |                         | 560   | 4    | 1.5  |
|      |            |           | Vertical                | 0   | 3    | —    |
|      |            |           |                         | 80  | 3    | —    |
|      |            |           |                         | 200   | 3    | —    |
|      |            |           |                         | 320   | 2.5  | —    |
|      |            |           |                         | 440   | 1    | —    |
|      |            |           |                         | 500   | —    | —    |
|      |            |           |                         | 560   | —    | —    |

[When high-output setting for motor straight type is ineffective]

(Note) If the stroke is long, lighten the payload according to the graph in "1.2.3 Allowable Payload".

• Double Guide Block (Option Model: DB)

| Type | Motor Type | Lead [mm] | Horizontal/<br>Vertical | Payload by<br>Acceleration/Deceleration<br>[kg] |      |      |    |
|------|------------|-----------|-------------------------|---|------|------|----|
|      |            |           |                         | Velocity<br>[mm/s]                              | 0.3G | 0.7G |    |
| TA7C | 56P        | 4         | Horizontal              | 0   | 30   | 26   |    |
|      |            |           |                         | 35  | 30   | 26   |    |
|      |            |           |                         | 70  | 25   | 18   |    |
|      |            |           |                         | 105   | 20   | 12   |    |
|      |            |           | Vertical                | 0   | 20   | —    |    |
|      |            |           |                         | 35  | 20   | —    |    |
|      |            | 8         | Horizontal              | 70  | 30   | 26   |    |
|      |            |           |                         | 140   | 25   | 18   |    |
|      |            |           |                         | 210   | 18   | 10   |    |
|      |            |           |                         | 280   | 4    | —    |    |
|      |            |           |                         | Vertical  | 0    | 12   | —  |
|      |            |           |                         |   | 70   | 12   | —  |
|      |            |           | 16                      | Horizontal                                      | 140  | 22   | 18 |
|      |            |           |                         |   | 280  | 16   | 14 |
|      |            |           |                         |   | 420  | 10   | 4  |
|      |            |           |                         |   | 560  | 2    | —  |
|      |            |           |                         | Vertical  | 0    | 5    | —  |
|      |            |           |                         |   | 140  | 5    | —  |
|      |            | 16        | Horizontal              | 280   | 5    | —    |    |
|      |            |           |                         | 420   | —    | —    |    |
|      |            |           | Vertical                | 280   | 5    | —    |    |
|      |            |           |                         | 420   | —    | —    |    |
|      |            |           | 16                      | Vertical  | 560  | —    | —  |

[When high-output setting for side-mounted motor type is ineffective]

(Note) If the stroke is long, lighten the payload according to the graph in "1.2.3 Allowable Payload".

• Standard Specification

| Type     | Motor Type | Lead [mm] | Horizontal/<br>Vertical | Payload by<br>Acceleration/Deceleration<br>[kg] |      |      |
|----------|------------|-----------|-------------------------|---|------|------|
|          |            |           |                         | Velocity<br>[mm/s]                              | 0.3G | 0.7G |
| TA4R     | 35P        | 2.5       | Horizontal              | 0   | 5    | 5    |
|          |            |           |                         | 20  | 5    | 5    |
|          |            |           |                         | 40  | 5    | 5    |
|          |            |           |                         | 65  | 5    | 5    |
|          |            |           |                         | 85  | 5    | 5    |
|          |            |           |                         | 105   | 5    | 5    |
|          |            |           | Vertical                | 130   | 5    | 5    |
|          |            |           |                         | 0   | 9    | —    |
|          |            |           |                         | 20  | 9    | —    |
|          |            |           |                         | 40  | 9    | —    |
|          |            |           |                         | 65  | 9    | —    |
|          |            |           |                         | 85  | 7.5  | —    |
|          |            | 5         | Horizontal              | 105   | 6    | —    |
|          |            |           |                         | 130   | 4    | —    |
|          |            |           |                         | 0   | 5    | 5    |
|          |            |           |                         | 40  | 5    | 5    |
|          |            |           |                         | 85  | 5    | 5    |
|          |            |           |                         | 130   | 5    | 5    |
|          |            |           | Vertical                | 175   | 5    | 5    |
|          |            |           |                         | 215   | 5    | 5    |
|          |            |           |                         | 260   | 5    | 5    |
|          |            |           |                         | 0   | 5    | —    |
|          |            |           |                         | 40  | 5    | —    |
|          |            |           |                         | 85  | 5    | —    |
| Vertical | 130        | 5         | —                       |   |      |      |
|          | 175        | 4.5       | —                       |   |      |      |
|          | 215        | 4         | —                       |   |      |      |
|          | 260        | 2.5       | —                       |   |      |      |

[When high-output setting for side-mounted motor type is ineffective]

(Note) If the stroke is long, lighten the payload according to the graph in "1.2.3 Allowable Payload".

• Standard Specification

| Type | Motor Type | Lead [mm] | Horizontal/<br>Vertical | Payload by<br>Acceleration/Deceleration<br>[kg] |      |      |
|------|------------|-----------|-------------------------|---|------|------|
|      |            |           |                         | Velocity<br>[mm/s]                              | 0.3G | 0.7G |
| TA4R | 35P        | 10        | Horizontal              | 0   | 4    | 4    |
|      |            |           |                         | 85  | 4    | 4    |
|      |            |           |                         | 175   | 4    | 4    |
|      |            |           |                         | 260   | 4    | 4    |
|      |            |           |                         | 350   | 4    | 4    |
|      |            |           |                         | 435   | 4    | 3.5  |
|      |            |           | 525                     | —   | 2    |      |
|      |            |           | Vertical                | 0   | 2.5  | —    |
|      |            |           |                         | 85  | 2.5  | —    |
|      |            |           |                         | 175   | 2.5  | —    |
|      |            |           |                         | 260   | 2.25 | —    |
|      |            |           |                         | 350   | 1.5  | —    |
|      |            | 435       |                         | 1   | —    |      |
|      |            | 16        | Horizontal              | 0   | 3    | 3    |
|      |            |           |                         | 140   | 3    | 3    |
|      |            |           |                         | 280   | 3    | 3    |
|      |            |           |                         | 420   | 3    | 3    |
|      |            |           |                         | 560   | 2.5  | 2    |
|      |            |           |                         | 700   | —    | 1.5  |
|      |            |           | 840                     | —   | 1    |      |
|      |            |           | Vertical                | 0   | 1    | —    |
|      |            |           |                         | 140   | 1    | —    |
|      |            |           |                         | 280   | 1    | —    |
|      |            |           |                         | 420   | 1    | —    |
| 560  | 0.75       |           |                         | —   |      |      |
| 700  | —          | —         |                         |   |      |      |
| 840  | —          | —         |                         |   |      |      |

[When high-output setting for side-mounted motor type is ineffective]

(Note) If the stroke is long, lighten the payload according to the graph in "1.2.3 Allowable Payload".

• Standard Specification

| Type | Motor Type | Lead [mm] | Horizontal/<br>Vertical | Payload by<br>Acceleration/Deceleration<br>[kg] |      |      |
|------|------------|-----------|-------------------------|---|------|------|
|      |            |           |                         | Velocity<br>[mm/s]                              | 0.3G | 0.7G |
| TA6R | 42P        | 3         | Horizontal              | 0   | 10   | 8    |
|      |            |           |                         | 20  | 10   | 8    |
|      |            |           |                         | 50  | 10   | 8    |
|      |            |           |                         | 80  | 10   | 8    |
|      |            |           |                         | 110   | 10   | 8    |
|      |            |           |                         | 125   | 9    | 8    |
|      |            |           |                         | 140   | 8    | 8    |
|      |            |           | 170                     | 7   | 6    |      |
|      |            |           | Vertical                | 0   | 12   | —    |
|      |            |           |                         | 20  | 12   | —    |
|      |            |           |                         | 50  | 12   | —    |
|      |            |           |                         | 80  | 12   | —    |
|      |            |           |                         | 110   | 9    | —    |
|      |            |           |                         | 125   | 7    | —    |
|      |            | 140       |                         | 5   | —    |      |
|      |            | 170       | —                       | —   |      |      |
|      |            | 6         | Horizontal              | 0   | 10   | 8    |
|      |            |           |                         | 40  | 10   | 8    |
|      |            |           |                         | 100   | 10   | 8    |
|      |            |           |                         | 160   | 10   | 8    |
|      |            |           |                         | 220   | 10   | 8    |
|      |            |           |                         | 250   | 9    | 8    |
|      |            |           |                         | 280   | 8    | 8    |
|      |            |           | 340                     | 6   | 3    |      |
|      |            |           | Vertical                | 0   | 6    | —    |
|      |            |           |                         | 40  | 6    | —    |
|      |            |           |                         | 100   | 6    | —    |
|      |            |           |                         | 160   | 6    | —    |
| 220  | 4          |           |                         | —   |      |      |
| 250  | 3          |           |                         | —   |      |      |
| 280  | 2          | —         |                         |   |      |      |
| 340  | —          | —         |                         |   |      |      |

[When high-output setting for side-mounted motor type is ineffective]

(Note) If the stroke is long, lighten the payload according to the graph in "1.2.3 Allowable Payload".

• Standard Specification

| Type | Motor Type | Lead [mm] | Horizontal/<br>Vertical | Payload by<br>Acceleration/Deceleration<br>[kg] |      |      |
|------|------------|-----------|-------------------------|---|------|------|
|      |            |           |                         | Velocity<br>[mm/s]                              | 0.3G | 0.7G |
| TA6R | 42P        | 12        | Horizontal              | 0   | 8    | 7    |
|      |            |           |                         | 80  | 8    | 7    |
|      |            |           |                         | 200   | 8    | 7    |
|      |            |           |                         | 320   | 8    | 7    |
|      |            |           |                         | 440   | 7    | 6    |
|      |            |           |                         | 500   | 6.5  | 4.5  |
|      |            |           | 560                     | 6   | 3    |      |
|      |            |           | 680                     | 3   | 1    |      |
|      |            |           | Vertical                | 0   | 3    | —    |
|      |            |           |                         | 80  | 3    | —    |
|      |            |           |                         | 200   | 3    | —    |
|      |            |           |                         | 320   | 3    | —    |
|      |            | 440       |                         | 2   | —    |      |
|      |            | 500       |                         | 1.5   | —    |      |
|      |            | 20        | Horizontal              | 560   | 1    | —    |
|      |            |           |                         | 680   | —    | —    |
|      |            |           |                         | 0   | 5    | 5    |
|      |            |           |                         | 160   | 5    | 5    |
|      |            |           |                         | 320   | 4.5  | 4.5  |
|      |            |           |                         | 480   | 4    | 4    |
|      |            |           | Vertical                | 640   | 3    | 3    |
|      |            |           |                         | 800   | —    | 2    |
|      |            |           |                         | 0   | 1    | —    |
|      |            |           |                         | 160   | 1    | —    |
| 320  | 1          |           |                         | —   |      |      |
| 480  | 1          |           |                         | —   |      |      |
| 640  | 0.75       | —         |                         |   |      |      |
| 800  | —          | —         |                         |   |      |      |

[When high-output setting for side-mounted motor type is ineffective]

(Note) If the stroke is long, lighten the payload according to the graph in "1.2.3 Allowable Payload".

• Standard Specification

| Type | Motor Type | Lead [mm] | Horizontal/<br>Vertical | Payload by<br>Acceleration/Deceleration<br>[kg] |      |      |
|------|------------|-----------|-------------------------|---|------|------|
|      |            |           |                         | Velocity<br>[mm/s]                              | 0.3G | 0.7G |
| TA7R | 56P        | 4         | Horizontal              | 0   | 15   | 15   |
|      |            |           |                         | 35  | 15   | 15   |
|      |            |           |                         | 70  | 15   | 15   |
|      |            |           |                         | 105   | 15   | 13   |
|      |            |           | 140                     | 6   | —    |      |
|      |            |           | Vertical                | 0   | 20   | —    |
|      |            |           |                         | 35  | 20   | —    |
|      |            |           |                         | 70  | 18   | —    |
|      |            | 105       |                         | 10  | —    |      |
|      |            | 140       | —                       | —   |      |      |
|      |            | 8         | Horizontal              | 0   | 15   | 15   |
|      |            |           |                         | 70  | 15   | 15   |
|      |            |           |                         | 140   | 15   | 15   |
|      |            |           |                         | 210   | 15   | 12   |
|      |            |           | 280                     | 10  | —    |      |
|      |            |           | Vertical                | 0   | 12   | —    |
| 70   | 12         |           |                         | —   |      |      |
| 140  | 12         |           |                         | —   |      |      |
| 210  | 3.5        | —         |                         |   |      |      |
| 280  | —          | —         |                         |   |      |      |

[When high-output setting for side-mounted motor type is ineffective]

(Note) If the stroke is long, lighten the payload according to the graph in "1.2.3 Allowable Payload".

• Standard Specification

| Type | Motor Type | Lead [mm] | Horizontal/<br>Vertical | Payload by<br>Acceleration/Deceleration<br>[kg] |      |      |
|------|------------|-----------|-------------------------|---|------|------|
|      |            |           |                         | Velocity<br>[mm/s]                              | 0.3G | 0.7G |
| TA7R | 56P        | 16        | Horizontal              | 0   | 12   | 10   |
|      |            |           |                         | 140   | 12   | 10   |
|      |            |           |                         | 280   | 12   | 10   |
|      |            |           |                         | 420   | 12   | 4    |
|      |            |           |                         | 560   | 5    | —    |
|      |            |           | Vertical                | 0   | 5    | —    |
|      |            |           |                         | 140   | 5    | —    |
|      |            |           |                         | 280   | 5    | —    |
|      |            |           |                         | 420   | —    | —    |
|      |            |           |                         | 560   | —    | —    |
|      |            | 24        | Horizontal              | 0   | 10   | 8    |
|      |            |           |                         | 200   | 10   | 8    |
|      |            |           |                         | 420   | 10   | 8    |
|      |            |           |                         | 640   | 5    | 1    |
|      |            |           |                         | 860   | 1    | —    |
|      |            |           | Vertical                | 0   | 3    | —    |
|      |            |           |                         | 200   | 3    | —    |
|      |            |           |                         | 420   | 3    | —    |
|      |            |           | 640                     | —   | —    |      |
|      |            |           | 860                     | —   | —    |      |

[When high-output setting for side-mounted motor type is ineffective]

(Note) If the stroke is long, lighten the payload according to the graph in "1.2.3 Allowable Payload".

• Double Guide Block (Option Model: DB)

| Type     | Motor Type | Lead [mm] | Horizontal/<br>Vertical | Payload by<br>Acceleration/Deceleration<br>[kg] |      |      |
|----------|------------|-----------|-------------------------|---|------|------|
|          |            |           |                         | Velocity<br>[mm/s]                              | 0.3G | 0.7G |
| TA4R     | 35P        | 2.5       | Horizontal              | 0   | 10   | 8    |
|          |            |           |                         | 20  | 10   | 8    |
|          |            |           |                         | 40  | 10   | 8    |
|          |            |           |                         | 65  | 9    | 8    |
|          |            |           |                         | 85  | 9    | 6    |
|          |            |           |                         | 105   | 9    | 6    |
|          |            |           | Vertical                | 130   | 8    | 5    |
|          |            |           |                         | 0   | 9    | —    |
|          |            |           |                         | 20  | 9    | —    |
|          |            |           |                         | 40  | 9    | —    |
|          |            |           |                         | 65  | 9    | —    |
|          |            |           |                         | 85  | 7.5  | —    |
|          |            | 5         | Horizontal              | 105   | 6    | —    |
|          |            |           |                         | 130   | 4    | —    |
|          |            |           |                         | 0   | 10   | 8    |
|          |            |           |                         | 40  | 10   | 8    |
|          |            |           |                         | 85  | 10   | 8    |
|          |            |           |                         | 130   | 9    | 8    |
|          |            |           | Vertical                | 175   | 9    | 6    |
|          |            |           |                         | 215   | 9    | 6    |
|          |            |           |                         | 260   | 8    | 5    |
|          |            |           |                         | 0   | 5    | —    |
|          |            |           |                         | 40  | 5    | —    |
|          |            |           |                         | 85  | 5    | —    |
| Vertical | 130        | 5         | —                       |   |      |      |
|          | 175        | 4.5       | —                       |   |      |      |
|          | 215        | 4         | —                       |   |      |      |
|          | 260        | 2.5       | —                       |   |      |      |

[When high-output setting for side-mounted motor type is ineffective]

(Note) If the stroke is long, lighten the payload according to the graph in "1.2.3 Allowable Payload".

• Double Guide Block (Option Model: DB)

| Type | Motor Type | Lead [mm] | Horizontal/<br>Vertical | Payload by<br>Acceleration/Deceleration<br>[kg] |      |      |
|------|------------|-----------|-------------------------|---|------|------|
|      |            |           |                         | Velocity<br>[mm/s]                              | 0.3G | 0.7G |
| TA4R | 35P        | 10        | Horizontal              | 0   | 8    | 6    |
|      |            |           |                         | 85  | 8    | 6    |
|      |            |           |                         | 175   | 8    | 6    |
|      |            |           |                         | 260   | 8    | 6    |
|      |            |           |                         | 350   | 7    | 5    |
|      |            |           |                         | 435   | 5    | 3.5  |
|      |            |           |                         | 525   | —    | 1.5  |
|      |            |           | Vertical                | 0   | 2.5  | —    |
|      |            |           |                         | 85  | 2.5  | —    |
|      |            |           |                         | 175   | 2.5  | —    |
|      |            |           |                         | 260   | 2.25 | —    |
|      |            |           |                         | 350   | 1.5  | —    |
|      |            |           |                         | 435   | 1    | —    |
|      |            |           |                         | 525   | —    | —    |

[When high-output setting for side-mounted motor type is ineffective]

(Note) If the stroke is long, lighten the payload according to the graph in "1.2.3 Allowable Payload".

• Double Guide Block (Option Model: DB)

| Type | Motor Type | Lead [mm] | Horizontal/<br>Vertical | Payload by<br>Acceleration/Deceleration<br>[kg] |      |      |
|------|------------|-----------|-------------------------|---|------|------|
|      |            |           |                         | Velocity<br>[mm/s]                              | 0.3G | 0.7G |
| TA6R | 42P        | 3         | Horizontal              | 0   | 20   | 16   |
|      |            |           |                         | 20  | 20   | 16   |
|      |            |           |                         | 50  | 20   | 16   |
|      |            |           |                         | 80  | 20   | 16   |
|      |            |           |                         | 110   | 20   | 16   |
|      |            |           |                         | 125   | 18   | 15   |
|      |            |           |                         | 140   | 15   | 14   |
|      |            |           | 170                     | 10  | 7    |      |
|      |            |           | Vertical                | 0   | 12   | —    |
|      |            |           |                         | 20  | 12   | —    |
|      |            |           |                         | 50  | 12   | —    |
|      |            |           |                         | 80  | 12   | —    |
|      |            |           |                         | 110   | 9    | —    |
|      |            |           |                         | 125   | 7    | —    |
|      |            | 140       |                         | 5   | —    |      |
|      |            | 170       | —                       | —   |      |      |
|      |            | 6         | Horizontal              | 0   | 20   | 16   |
|      |            |           |                         | 40  | 20   | 16   |
|      |            |           |                         | 100   | 20   | 16   |
|      |            |           |                         | 160   | 20   | 16   |
|      |            |           |                         | 220   | 20   | 16   |
|      |            |           |                         | 250   | 17   | 12   |
|      |            |           |                         | 280   | 14   | 8    |
|      |            |           | 340                     | 5   | 3    |      |
|      |            |           | Vertical                | 0   | 6    | —    |
|      |            |           |                         | 40  | 6    | —    |
|      |            |           |                         | 100   | 6    | —    |
|      |            |           |                         | 160   | 6    | —    |
| 220  | 4          |           |                         | —   |      |      |
| 250  | 3          |           |                         | —   |      |      |
| 280  | 2          | —         |                         |   |      |      |
| 340  | —          | —         |                         |   |      |      |

[When high-output setting for side-mounted motor type is ineffective]

(Note) If the stroke is long, lighten the payload according to the graph in "1.2.3 Allowable Payload".

• Double Guide Block (Option Model: DB)

| Type | Motor Type | Lead [mm] | Horizontal/<br>Vertical | Payload by<br>Acceleration/Deceleration<br>[kg] |      |      |
|------|------------|-----------|-------------------------|---|------|------|
|      |            |           |                         | Velocity<br>[mm/s]                              | 0.3G | 0.7G |
| TA6R | 42P        | 12        | Horizontal              | 0   | 15   | 11   |
|      |            |           |                         | 80  | 15   | 11   |
|      |            |           |                         | 200   | 15   | 11   |
|      |            |           |                         | 320   | 15   | 10   |
|      |            |           |                         | 440   | 9    | 5    |
|      |            |           |                         | 500   | 6    | 3    |
|      |            |           |                         | 560   | 4    | 1.5  |
|      |            |           | Vertical                | 0   | 3    | —    |
|      |            |           |                         | 80  | 3    | —    |
|      |            |           |                         | 200   | 3    | —    |
|      |            |           |                         | 320   | 2.5  | —    |
|      |            |           |                         | 440   | 1    | —    |
|      |            |           |                         | 500   | —    | —    |
|      |            |           |                         | 560   | —    | —    |

[When high-output setting for side-mounted motor type is ineffective]

(Note) If the stroke is long, lighten the payload according to the graph in "1.2.3 Allowable Payload".

● Double Guide Block (Option Model: DB)

| Type     | Motor Type | Lead [mm] | Horizontal/<br>Vertical | Payload by<br>Acceleration/Deceleration<br>[kg] |      |      |
|----------|------------|-----------|-------------------------|---|------|------|
|          |            |           |                         | Velocity<br>[mm/s]                              | 0.3G | 0.7G |
| TA7R     | 56P        | 4         | Horizontal              | 0   | 30   | 26   |
|          |            |           |                         | 35  | 30   | 26   |
|          |            |           |                         | 70  | 25   | 18   |
|          |            |           |                         | 105   | 20   | 12   |
|          |            |           | Vertical                | 0   | 20   | —    |
|          |            |           |                         | 35  | 20   | —    |
|          |            |           |                         | 70  | 20   | —    |
|          |            |           |                         | 105   | 10   | —    |
|          |            | 8         | Horizontal              | 0   | 30   | 26   |
|          |            |           |                         | 70  | 30   | 26   |
|          |            |           |                         | 140   | 25   | 18   |
|          |            |           |                         | 210   | 18   | 10   |
|          |            |           | Vertical                | 280   | 4    | —    |
|          |            |           |                         | 0   | 12   | —    |
|          |            |           |                         | 70  | 12   | —    |
|          |            |           |                         | 140   | 12   | —    |
|          |            | 16        | Horizontal              | 210   | 3.5  | —    |
|          |            |           |                         | 280   | —    | —    |
|          |            |           |                         | 0   | 22   | 18   |
|          |            |           |                         | 140   | 22   | 18   |
|          |            |           | Vertical                | 280   | 16   | 14   |
|          |            |           |                         | 420   | 10   | 4    |
|          |            |           |                         | 560   | 2    | —    |
|          |            |           |                         | 0   | 5    | —    |
| Vertical | 140        | 5         | —                       |   |      |      |
|          | 280        | 5         | —                       |   |      |      |
|          | 420        | —         | —                       |   |      |      |
|          | 560        | —         | —                       |   |      |      |

 **Caution:** Do not attempt to establish the settings for the acceleration/deceleration above the allowable range. It may cause a vibration, malfunction or shorten the product life. If any acceleration/deceleration equal to or greater than the rated acceleration/deceleration is set, a creep phenomenon or slipped coupling may occur.

### 1.2.3 Allowable Transportable Mass

If the stroke is long, lighten the transportable mass according to the following graph.

[TA4C, TA4R]

- Horizontal installation

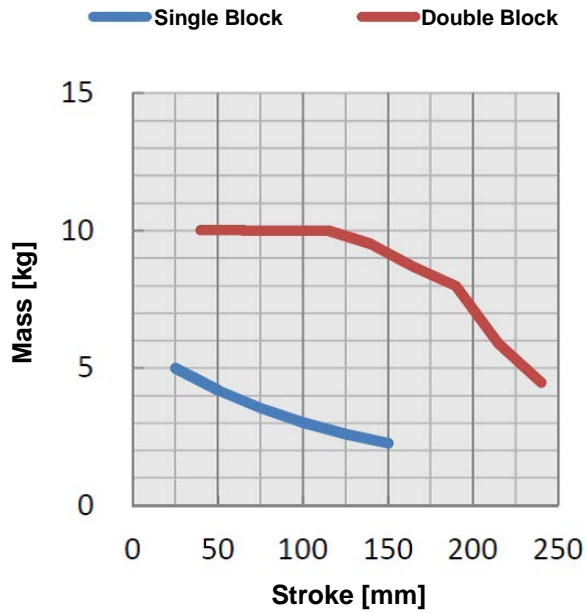

- Sideway installation

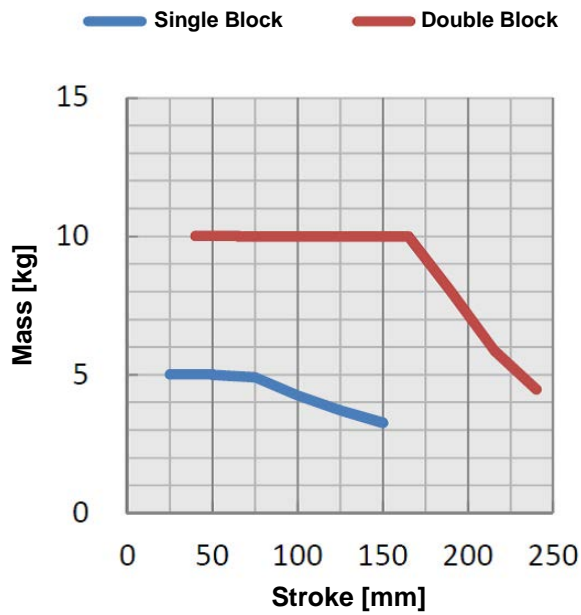

- Vertical installation

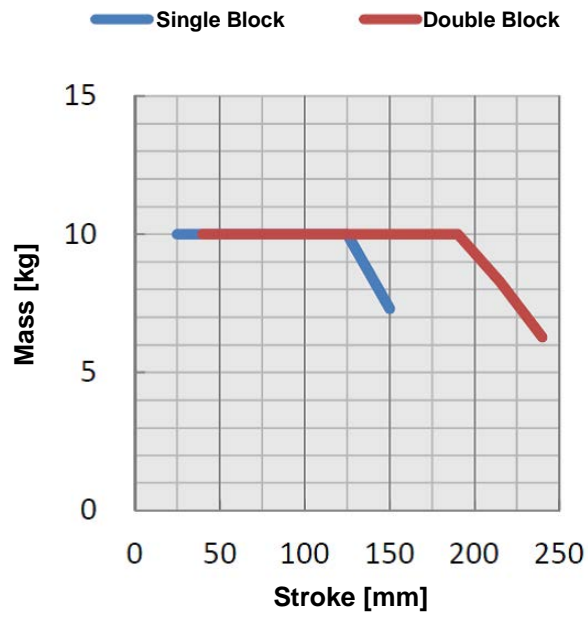

[TA6C, TA6R]

- Horizontal installation

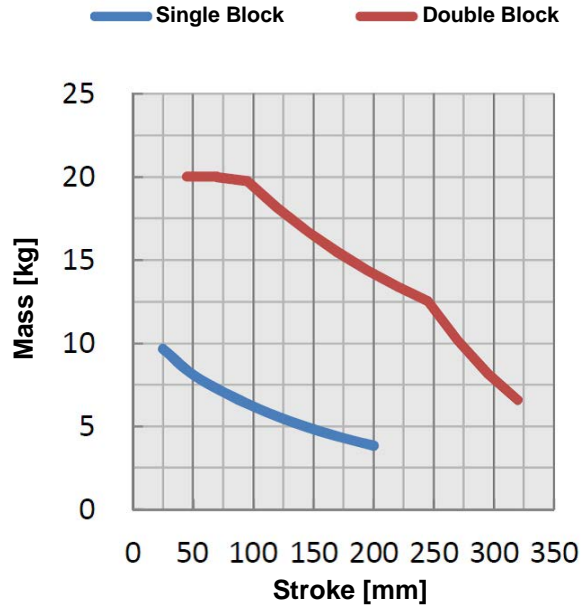

- Sideway installation

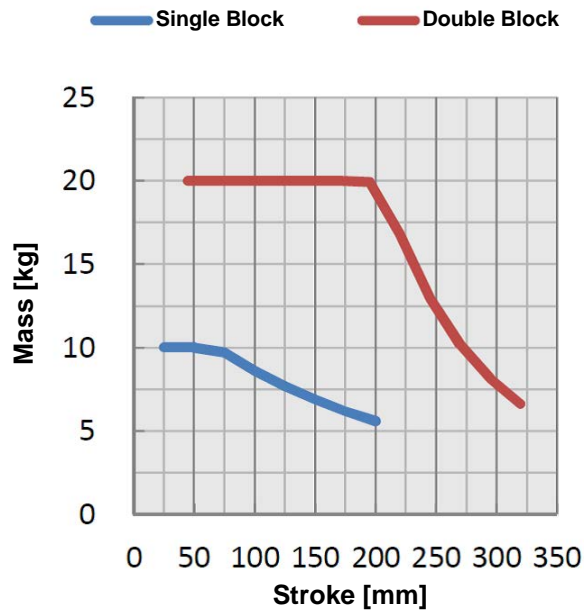

- Vertical installation

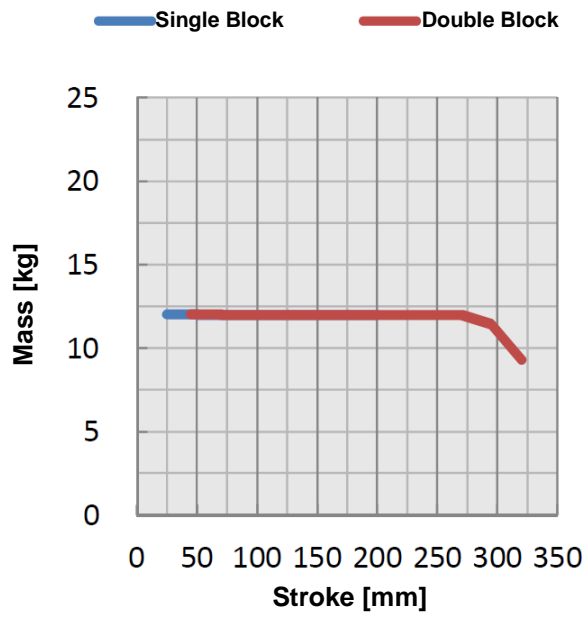

[TA7C, TA7R]

- Horizontal installation

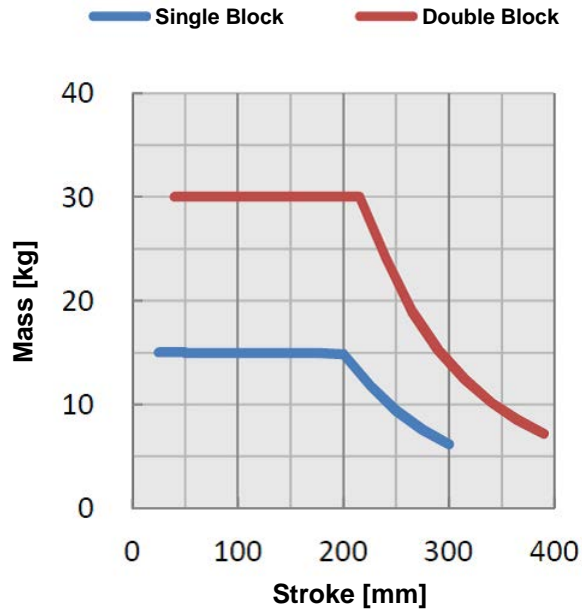

- Sideway installation

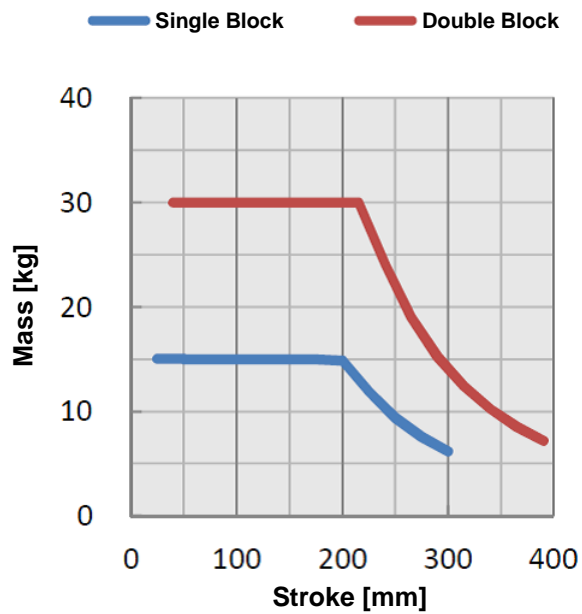

- Vertical installation

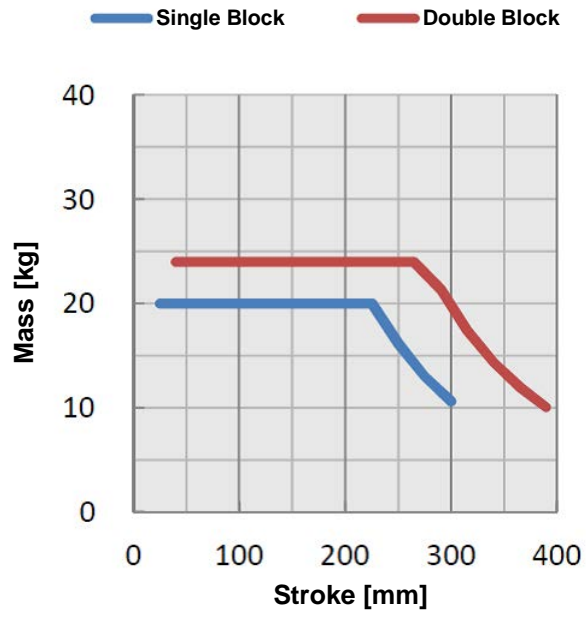

### 1.2.4 Driving System • Position Detector

| Type         | Motor Type | Lead | No. of Encoder Pulses | Ball Screw Type |          |          |       |     |
|--------------|------------|------|-----------------------|-----------------|----------|----------|-------|-----|
|              |            |      |                       | Type            | Diameter | Accuracy |       |     |
| TA4C<br>TA4R | 35P        | 2.5  | 8192                  | Rolled          | φ8mm     | C10      |       |     |
|              |            | 5    |                       |                 |          |          |       |     |
|              |            | 10   |                       |                 |          |          |       |     |
|              |            | 16   |                       |                 |          |          |       |     |
| TA6C<br>TA6R | 42P        | 3    |                       | 8192            | Rolled   | φ10mm    | C10   |     |
|              |            | 6    |                       |                 |          |          |       |     |
|              |            | 12   |                       |                 |          |          |       |     |
|              |            | 20   |                       |                 |          |          |       |     |
| TA7C<br>TA7R | 56P        | 4    |                       |                 | 8192     | Rolled   | φ12mm | C10 |
|              |            | 8    |                       |                 |          |          |       |     |
|              |            | 16   |                       |                 |          |          |       |     |
|              |            | 24   |                       |                 |          |          |       |     |

### 1.2.5 Positioning Precision

| Type         | Lead              | Item                      | Tolerance     |
|--------------|-------------------|---------------------------|---------------|
|              |                   |                           | Standard      |
| TA4C<br>TA4R | 2.5, 5,<br>10, 16 | Positioning repeatability | ±0.01mm       |
|              |                   | Lost motion               | 0.1mm or less |
| TA6C<br>TA6R | 3, 6,<br>12, 20   | Positioning repeatability | ±0.01mm       |
|              |                   | Lost motion               | 0.1mm or less |
| TA7C<br>TA7R | 4, 8,<br>16, 24   | Positioning repeatability | ±0.01mm       |
|              |                   | Lost motion               | 0.1mm or less |

This is an option already attached when it is shipped out from the factory. It does not include the consideration of time-dependent change as it is used.

## 1.2.6 Current Limit Value and Pressing Force

### • TA4C, TA4R

| Current Limit Value | Lead 2.5 [N] | Lead 5 [N] | Lead 10 [N] | Lead 16 [N] |
|---------------------|--------------|------------|-------------|-------------|
| 20%                 | 89           | 44         | 22          | -           |
| 30%                 | 133          | 66         | 33          | 21          |
| 40%                 | 177          | 89         | 44          | 27          |
| 50%                 | 221          | 111        | 55          | 34          |
| 60%                 | 266          | 133        | 66          | 41          |
| 70%                 | 310          | 155        | 77          | 48          |

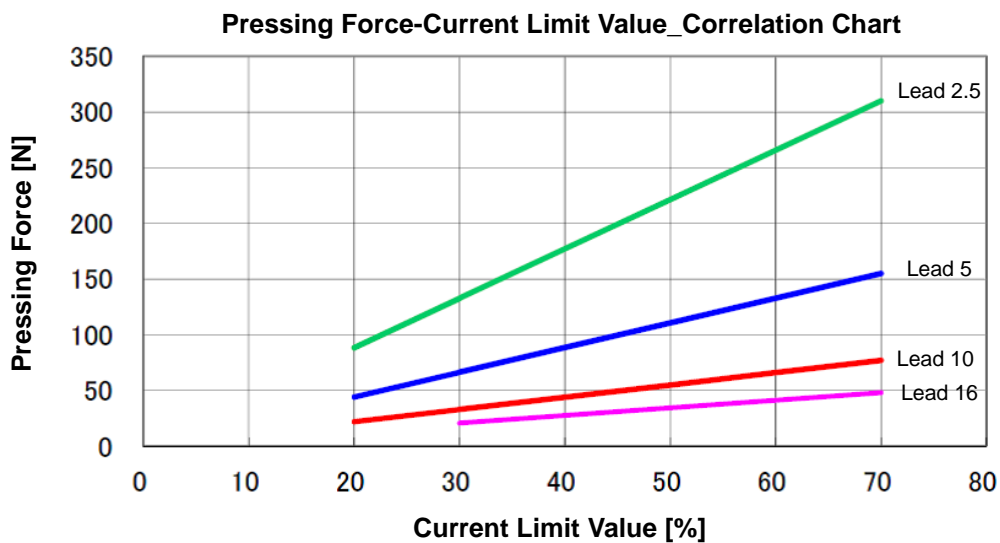

- ⚠ Caution:**
- (1) The relation of the current limit and the pressing force is a reference when assuming the speed is 20mm/s.
  - (2) There is a little variance in the actual pressing force. The variance of the pressing force becomes large when the current limit value is low.
  - (3) Use the product within the range in the graph for the current limit value. Pressing force will not be stable if used below 20%. There is even a case that it would not operate. An operation cannot be made also when it is beyond 70%. Doing so may cause degradation in the motor coil insulation by heat radiation, which results in shortening the product life.
  - (4) For CON-system controllers such as PCON, when the approach speed to the pressing start position (setting in the position table) is 20mm/s or less, pressing will be performed with the approach speed. In such a case also the pressing force will be unstable. In such cases, check in advance that the actuator can be used with no problem before omit using.  
For SEL-system controllers, such as MSEL, press at the speed set by PAPER instruction, regardless of the approach speed up to the pressing start position.

• TA6C, TA6R

| Current Limit Value | Lead 3 [N] | Lead 6 [N] | Lead 12 [N] | Lead 20 [N] |
|---------------------|------------|------------|-------------|-------------|
| 20%                 | 106        | 53         | 26          | 16          |
| 30%                 | 159        | 79         | 40          | 24          |
| 40%                 | 211        | 106        | 53          | 32          |
| 50%                 | 264        | 132        | 66          | 40          |
| 60%                 | 317        | 159        | 79          | 48          |
| 70%                 | 370        | 185        | 93          | 56          |

※ This is a reference at 20mm/s of pressing speed.

Pressing Force-Current Limit Value\_Correlation Chart

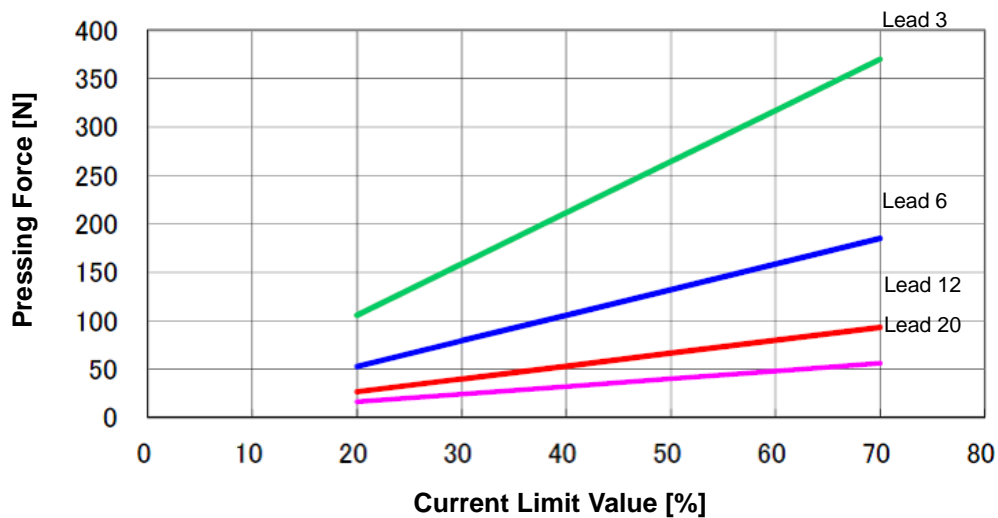

⚠ Caution: (1) The relation of the current limit and the pressing force is a reference when assuming the speed is 20mm/s.  
 (2) There will be a little variance in the actual pressing force. The variance of the pressing force becomes large when the current limit value is low.  
 (3) Use the product within the range in the graph for the current limit value. Pressing force will not be stable if used below 20%. There is even a case that it would not operate. An operation cannot be made also when it is beyond 70%. Doing so may cause degradation in the motor coil insulation by heat radiation, which results in shortening the product life.  
 (4) For CON-system controllers such as PCON, when the approach speed to the pressing start position (setting in the position table) is 20mm/s or less, pressing will be performed with the approach speed. In such a case also the pressing force will be unstable. In such cases, check in advance that the actuator can be used with no problem before omit using.  
 For SEL-system controllers, such as MSEL, press at the speed set by PAPER instruction, regardless of the approach speed up to the pressing start position.

• TA7C, TA7R

| Current Limit Value | Lead 4 [N] | Lead 8 [N] | Lead 16 [N] | Lead 24 [N] |
|---------------------|------------|------------|-------------|-------------|
| 20%                 | 192        | 96         | 48          | 32          |
| 30%                 | 288        | 144        | 72          | 48          |
| 40%                 | 385        | 192        | 96          | 64          |
| 50%                 | 481        | 240        | 120         | 80          |
| 60%                 | 577        | 288        | 144         | 96          |
| 70%                 | 673        | 336        | 168         | 112         |

※ This is a reference at 20mm/s of pressing speed.

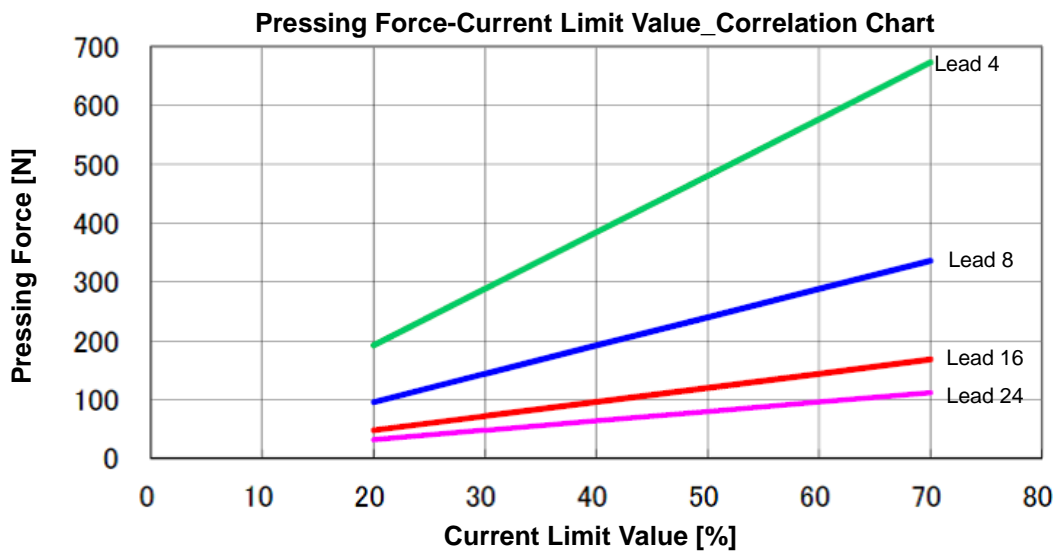

- ⚠ Caution:
- (1) The relation of the current limit and the pressing force is a reference when assuming the speed is 20mm/s.
  - (2) There will be a little variance in the actual pressing force. The variance of the pressing force becomes large when the current limit value is low.
  - (3) Use the product within the range in the graph for the current limit value. Pressing force will not be stable if used below 20%. There is even a case that it would not operate. An operation cannot be made also when it is beyond 70%. Doing so may cause degradation in the motor coil insulation by heat radiation, which results in shortening the product life.
  - (4) For CON-system controllers such as PCON, when the approach speed to the pressing start position (setting in the position table) is 20mm/s or less, pressing will be performed with the approach speed. In such a case also the pressing force will be unstable. In such cases, check in advance that the actuator can be used with no problem before omit using.  
For SEL-system controllers, such as MSEL, press at the speed set by PAPER instruction, regardless of the approach speed up to the pressing start position.

## 1.2.7 Allowable Moment of Actuator

| Type         |                        | Allowable static moment [N·m] |      |      | Allowable dynamic moment [N·m] |      |      | Allowable overhang Load (L)             |
|--------------|------------------------|-------------------------------|------|------|--------------------------------|------|------|---|
|              |                        | Ma                            | Mb   | Mc   | Ma                             | Mb   | Mc   |   |
| TA4C<br>TA4R | Standard Specification | 13.0                          | 18.6 | 25.3 | 4.98                           | 7.11 | 9.68 | Within the range of dynamic load moment |
|              | Double Guide Block     | 76.8                          | 110  | 50.5 | 23.9                           | 34.1 | 15.7 |   |
| TA6C<br>TA6R | Standard Specification | 32.3                          | 46.2 | 68.3 | 11.6                           | 16.6 | 24.6 |   |
|              | Double Guide Block     | 169                           | 242  | 137  | 49.5                           | 70.7 | 40   |   |
| TA7C<br>TA7R | Standard Specification | 115                           | 115  | 229  | 44.7                           | 44.7 | 89.1 |   |
|              | Double Guide Block     | 620                           | 620  | 458  | 196                            | 196  | 145  |   |

Allowable dynamic moment is a moment in the case of the operation life of 5,000 km. [Refer to 6. "Life"]

The figure shows the table position at the home position (0mm)  
 With the stroke movement of the table, the gravity center of the load moves,  
 and the load moment  $M_a$  (when installed horizontally) or  $M_b$  (when installed sideways) will increase or decrease.

- TA4C, TA4R

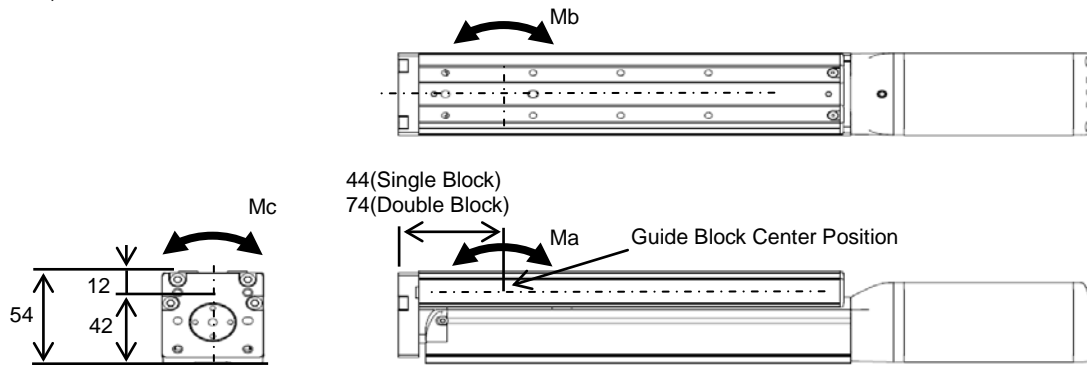

• TA6C, TA6R

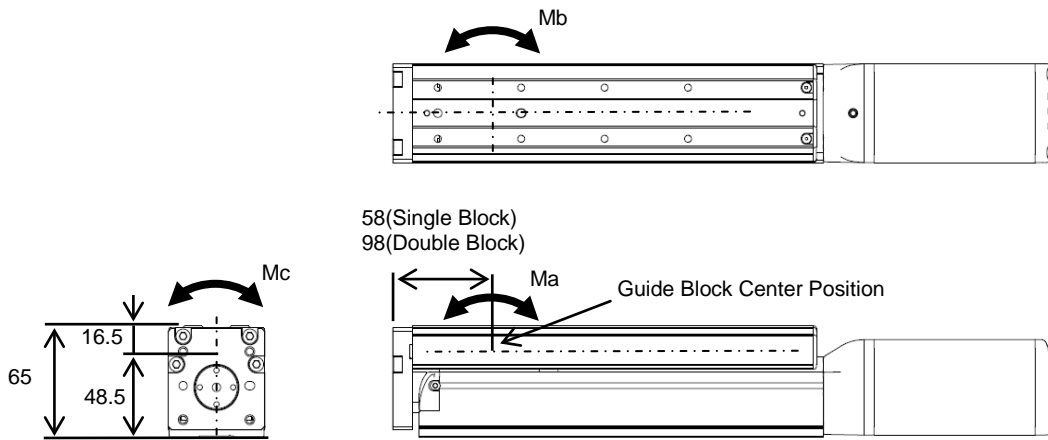

• TA7C, TA7R

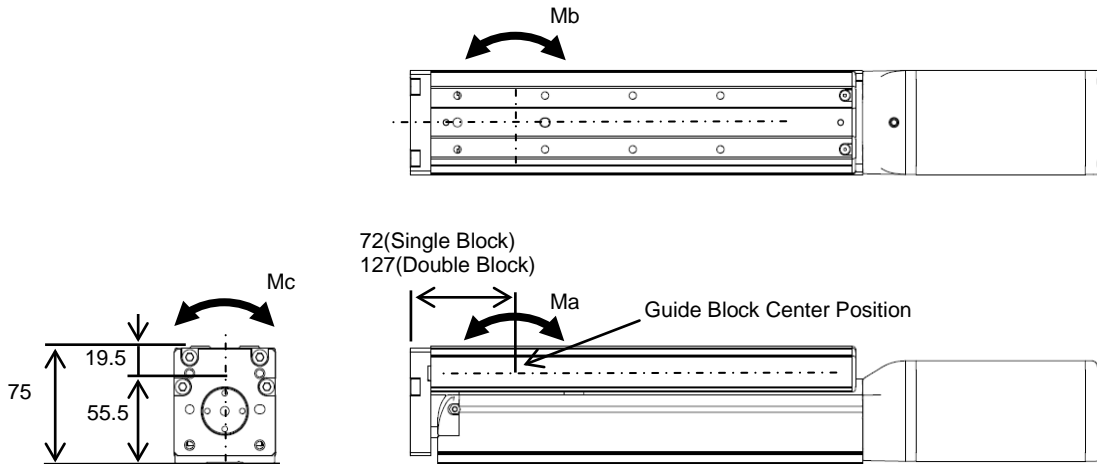

 Note: If the actuator is used with exceeding allowable moment and overhang load, it would not only cause noise and vibration, but also it may significantly reduce the life of the actuator.

## 1.2.8 Moment Load Displacement Amount

- TA4C, TA4R

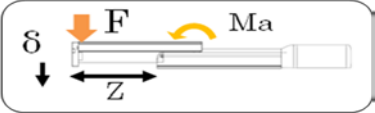
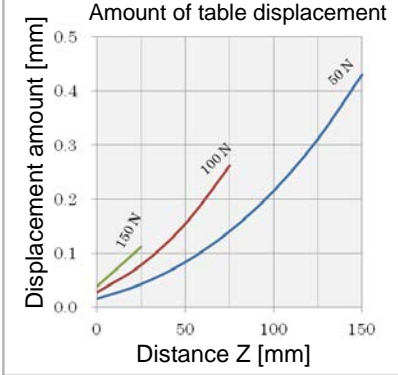
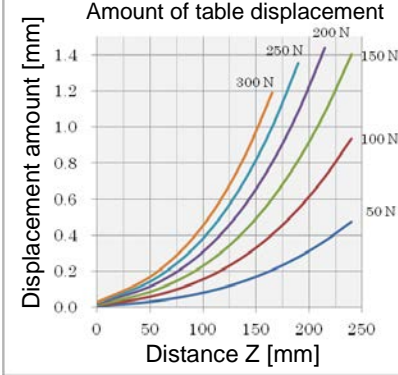
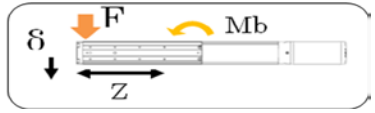
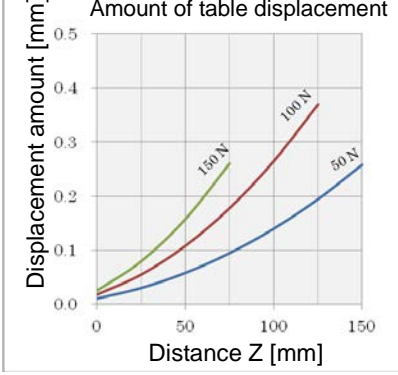
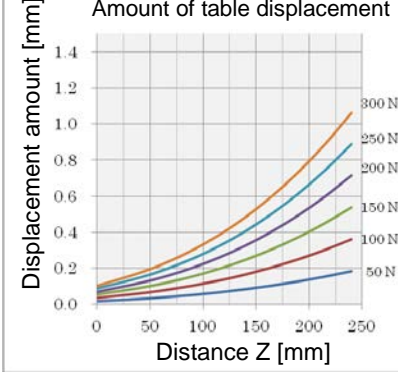
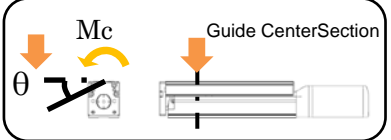
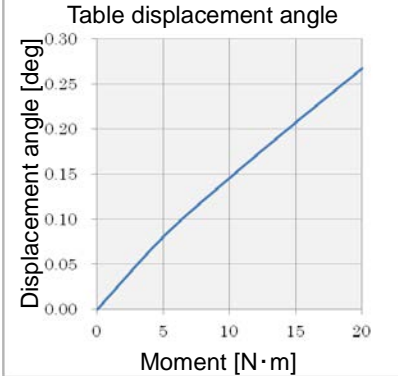
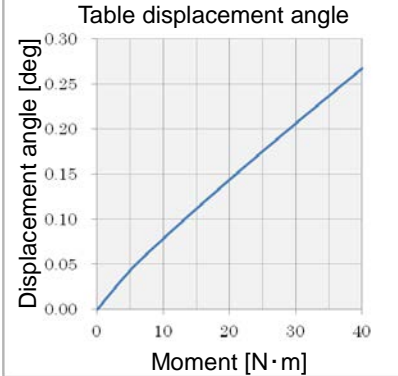
|   | Standard Specification  | Double Guide Block   |
|---|---|--|
| <p>[Ma direction moment load - Displacement amount]<br/>Amount of table displacement when Ma direction moment load F is applied to the table tip with the table moved to the distance Z</p>    | <p>Amount of table displacement</p>   | <p>Amount of table displacement</p>   |
| <p>[Mb direction moment load - Displacement amount]<br/>Amount of table displacement when Mb direction moment load F is applied to the table tip with the table moved to the distance Z</p>  | <p>Amount of table displacement</p>  | <p>Amount of table displacement</p>  |
| <p>[Mc direction moment - displacement angle]<br/>Displacement angle when Mc direction moment is applied on the guide center section to the table</p>                                        | <p>Table displacement angle</p>     | <p>Table displacement angle</p>     |

•TA6C, TA6R

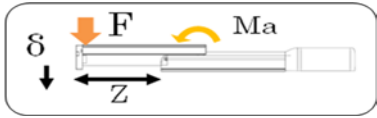
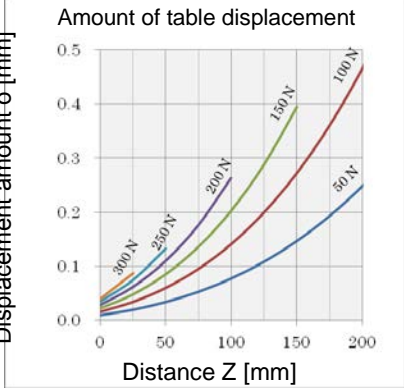
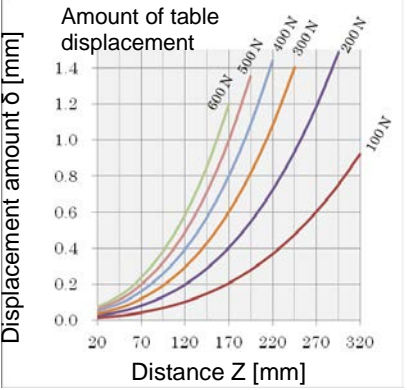
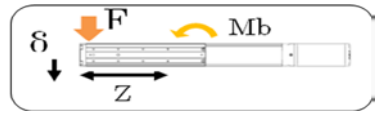
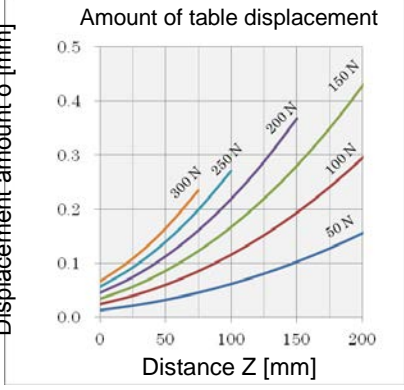
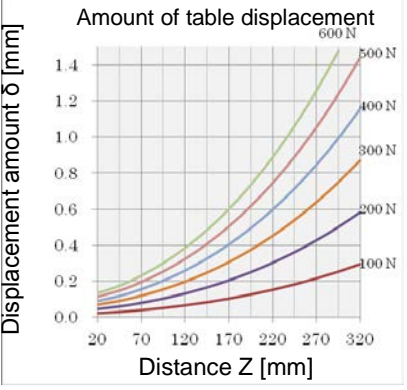
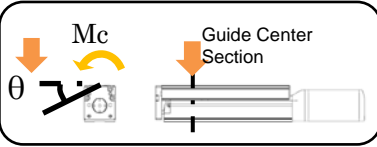
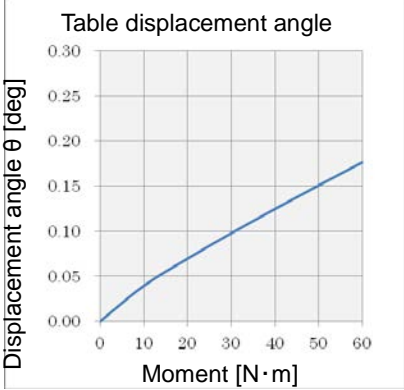
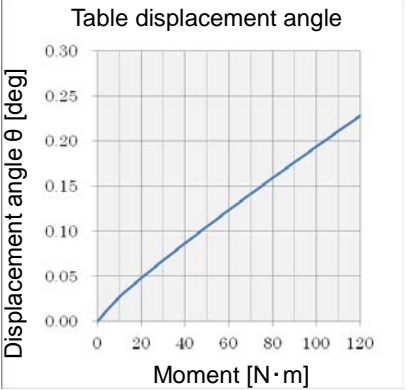
|   | Standard Specification  | Double Guide Block   |
|---|---|--|
| <p>[Ma direction moment load - Displacement amount]<br/>Amount of table displacement when Ma direction moment load F is applied to the table tip with the table moved to the distance Z</p>    | <p>Amount of table displacement</p>   | <p>Amount of table displacement</p>   |
| <p>[Mb direction moment load - Displacement amount]<br/>Amount of table displacement when Mb direction moment load F is applied to the table tip with the table moved to the distance Z</p>  | <p>Amount of table displacement</p>  | <p>Amount of table displacement</p>  |
| <p>[Mc direction moment - displacement angle]<br/>Displacement angle when Mc direction moment is applied on the guide center section to the table</p>                                        | <p>Table displacement angle</p>     | <p>Table displacement angle</p>     |

- TA7C, TA7R

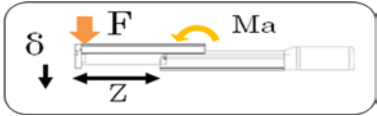
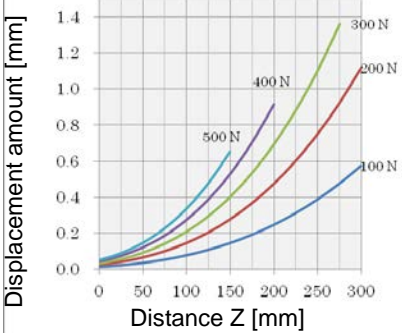
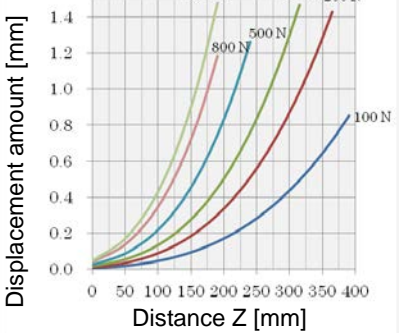
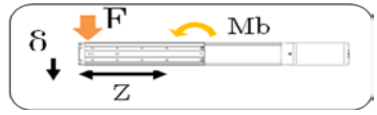
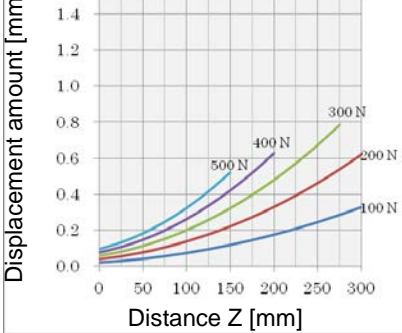
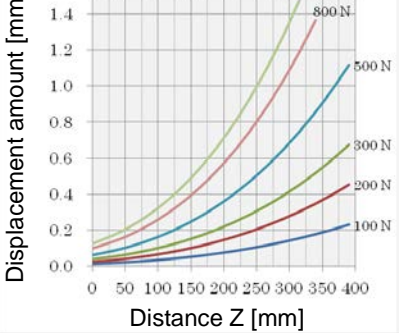
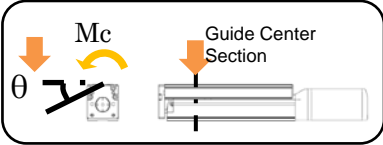
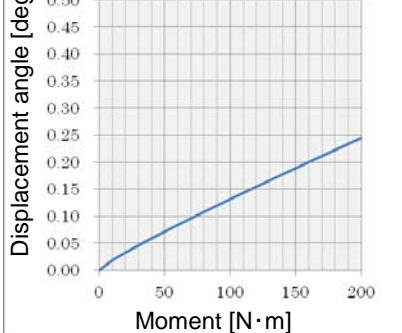
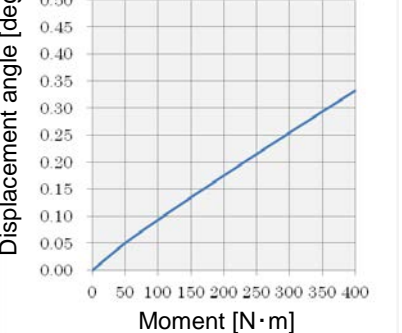
|   | Standard Specification  | Double Guide Block   |
|---|---|--|
| <p>[Ma direction moment load - Displacement amount]<br/>Amount of table displacement when Ma direction moment load F is applied to the table tip with the table moved to the distance Z</p>    | <p>Amount of table displacement</p>   | <p>Amount of table displacement</p>   |
| <p>[Mb direction moment load - Displacement amount]<br/>Amount of table displacement when Mb direction moment load F is applied to the table tip with the table moved to the distance Z</p>  | <p>Amount of table displacement</p>  | <p>Amount of table displacement</p>  |
| <p>[Mc direction moment - displacement angle]<br/>Displacement angle when Mc direction moment is applied on the guide center section to the table</p>                                        | <p>Table displacement angle</p>     | <p>Table displacement angle</p>     |

## 1.2.9 Duty Ratio for Continuous Operation

[Standard Specification]

It can operate continuously when the duty ratio is 100%.

[Built-in Controller Specification]

◎ RCP6S-TA4C, 4R

It can operate continuously when the duty ratio is 100%.

◎ RCP6S-TA6C, 6R

Lead 12mm and 20mm can operate continuously when the duty ratio is 100%.

Operate with the duty ratio as in the following graph for lead 3mm and 6mm.

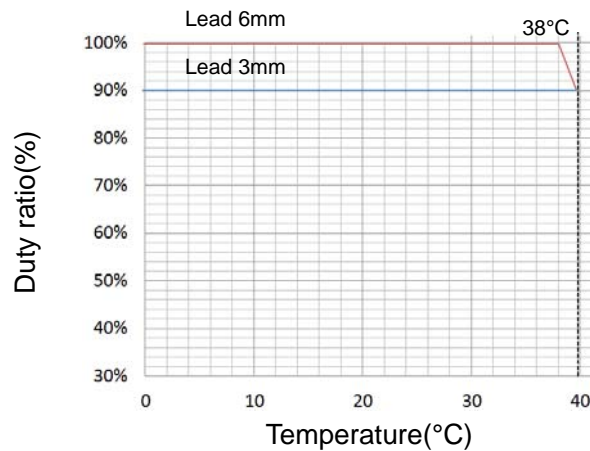

◎ RCP6S-TA7C, 7R

Lead 24mm can operate continuously when the duty ratio is 100%.

Operate with the duty ratio as in the following graph for lead 4mm, 8mm, and 16mm.

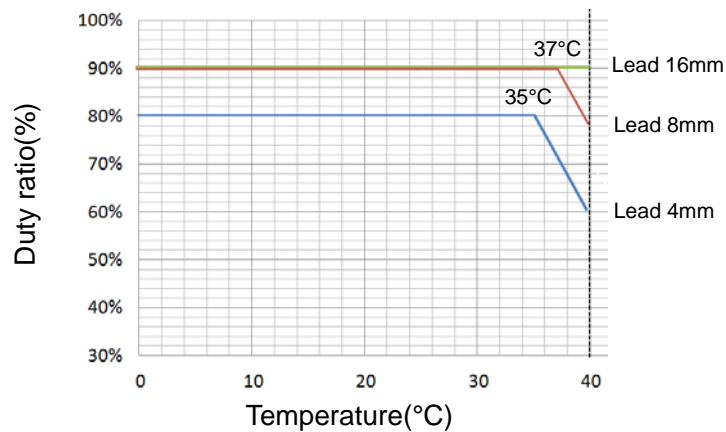

Duty ratio is an operating rate, which indicates the time that the actuator is running in one cycle by percentage.

## 1.3 Options

### 1.3.1 Brake Type (Model : B)

The brake is a mechanism designed to prevent the table from dropping on a vertically installed actuator when the power or servo is turned OFF.

Use the brake to prevent the installed load, etc., from being damaged due to the falling table.

### 1.3.2 Reversed-home Specification (Model : NM)

The standard home position is on the motor side. However, the motor position will be reversed if it is desirable in view of the layout of the system, etc.

(Note) The home position is adjusted at the factory before shipment. If you wish to change the home after the delivery of your actuator, you must return the actuator to IAI for adjustment.

### 1.3.3 Motor Left Side-Mounted, Motor Right Side-Mounted (Model: ML, MR)

From the view of the motor side, the type with the side-mounted to the left is ML and the motor side-mounted to the right is MR.

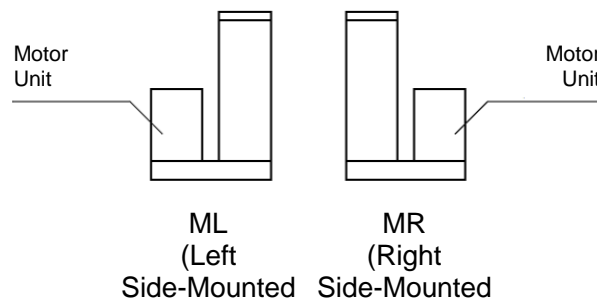

### 1.3.4 Cable Exit Direction Changed (Model: CJT, CJR, CJL, CJB, CJO)

If a change in the cable exit direction is made, the direction of cable exit will be changed. Ejection directions of Motor Straight Type TA4C, TA6C, TA7C are top (model: CJT), right (model: CJR), left (model: CJL), and bottom (model: CJB). Ejection direction of Side-Mounted Motor Type TA4R, TA6R, TA7R, TA8R is outward (model: CJO).

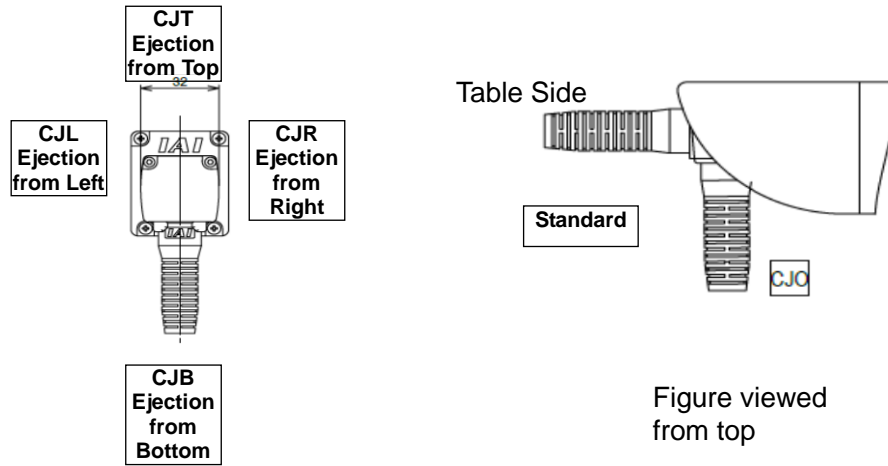
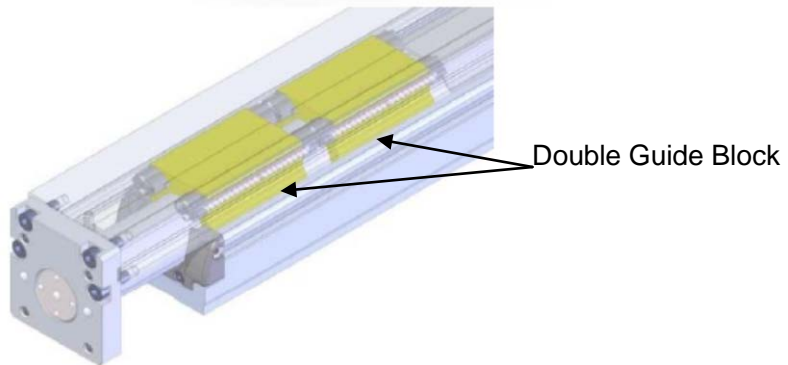

Figure viewed from motor side

### 1.3.5 High Rigidity Specification (Double Guide Block) (Model: DB)

By making the guide block double, dynamic allowable moment and transportable mass at the time of horizontal flat installation will improve.



## 1.4 Motor • Encoder Cables

### 1.4.1 Motor • Encoder Integrated Cables

CB-CAN-MPA□□□

□□□ indicates the cable length (L) (Example: 030=3m), Max.20m

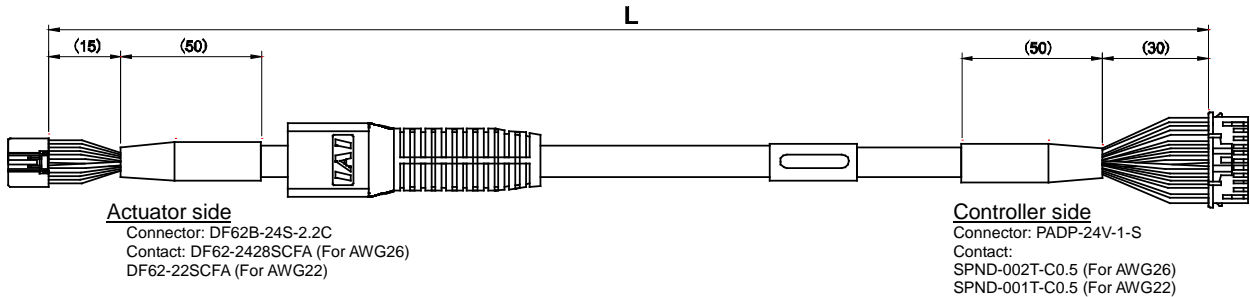

Connection diagram

| Actuator side |                     |          |         | Controller side |          |                     |           |
|---------------|---------------------|----------|---------|-----------------|----------|---------------------|-----------|
| Thickness     | Electric Wire Color | Symbol   | Pin No. | Pin No.         | Symbol   | Electric Wire Color | Thickness |
| AWG22/19      | Blue                | $\phi$ A | 3       | 1               | $\phi$ A | Blue                | AWG22/19  |
| AWG22/19      | Orange              | VMM      | 5       | 2               | VMM      | Orange              | AWG22/19  |
| AWG22/19      | Brown               | $\phi$ B | 10      | 3               | $\phi$ B | Brown               | AWG22/19  |
| AWG22/19      | Gray                | VMM      | 9       | 4               | VMM      | Gray                | AWG22/19  |
| AWG22/19      | Green               | $\phi$ A | 4       | 5               | $\phi$ A | Green               | AWG22/19  |
| AWG22/19      | Red                 | $\phi$ B | 15      | 6               | $\phi$ B | Red                 | AWG22/19  |
| AWG26         | Black               | LS+      | 8       | 7               | LS+      | Black               | AWG26     |
| AWG26         | Yellow              | LS-      | 14      | 8               | LS-      | Yellow              | AWG26     |
| AWG26         | Blue                | SA       | 12      | 11              | SA       | Blue                | AWG26     |
| AWG26         | Orange              | SB       | 17      | 12              | SB       | Orange              | AWG26     |
| AWG26         | Green               | A+       | 1       | 13              | A+       | Green               | AWG26     |
| AWG26         | Brown               | A-       | 6       | 14              | A-       | Brown               | AWG26     |
| AWG26         | Gray                | B+       | 11      | 15              | B+       | Gray                | AWG26     |
| AWG26         | Red                 | B-       | 16      | 16              | B-       | Red                 | AWG26     |
| AWG26         | Blue                | BK+      | 20      | 9               | BK+      | Blue                | AWG26     |
| AWG26         | Orange              | BK-      | 2       | 10              | BK-      | Orange              | AWG26     |
| AWG26         | Gray                | VCC      | 21      | 17              | VCC      | Gray                | AWG26     |
| AWG26         | Red                 | GND      | 7       | 19              | GND      | Red                 | AWG26     |
| AWG26         | Brown               | VPS      | 18      | 18              | VPS      | Brown               | AWG26     |
| AWG26         | Green               | LS_GND   | 13      | 20              | LS_GND   | Green               | AWG26     |
| -             | -                   | -        | 19      | 22              | -        | -                   | -         |
| AWG26         | Pink                | -        | 22      | 21              | -        | Pink                | AWG26     |
| -             | -                   | -        | 23      | 23              | -        | -                   | -         |
| AWG26         | Black               | FG       | 24      | 24              | FG       | Black               | AWG26     |

(Note) About thickness AWG22/19

The thickness is AWG22 when the cable length is 5m or less, and AWG19 when longer than 5m.

### 1.4.2 Motor • Encoder Integrated Cables Robot Type

CB-CAN-MPA□□□-RB

□□□ indicates the cable length (L) (Example: 030=3m), Max.20m

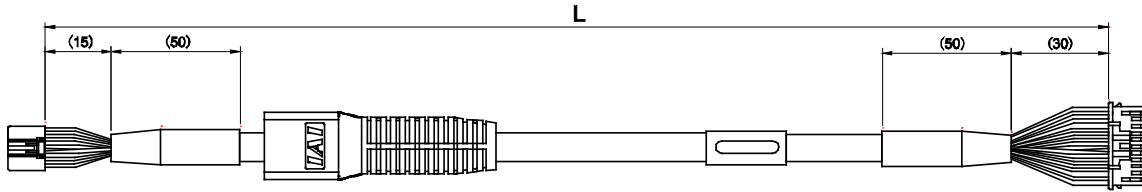

**Actuator side**

Connector: DF62B-24S-2.2C  
 Contact: DF62-2428SCFA (For AWG26)  
 DF62-22SCFA (For AWG22)

**Controller side**

Connector: PADP-24V-1-S  
 Contact: SPND-002T-C0.5 (For AWG26)  
 SPND-001T-C0.5 (For AWG22)

Connection diagram

| Actuator side |                     |          |         | Controller side |          |                     |           |
|---------------|---------------------|----------|---------|-----------------|----------|---------------------|-----------|
| Thickness     | Electric Wire Color | Symbol   | Pin No. | Pin No.         | Symbol   | Electric Wire Color | Thickness |
| AWG22/19      | Blue                | $\phi$ A | 3       | 1               | $\phi$ A | Blue                | AWG22/19  |
| AWG22/19      | Orange              | VMM      | 5       | 2               | VMM      | Orange              | AWG22/19  |
| AWG22/19      | Brown               | $\phi$ B | 10      | 3               | $\phi$ B | Brown               | AWG22/19  |
| AWG22/19      | Gray                | VMM      | 9       | 4               | VMM      | Gray                | AWG22/19  |
| AWG22/19      | Green               | $\phi$ A | 4       | 5               | $\phi$ A | Green               | AWG22/19  |
| AWG22/19      | Red                 | $\phi$ B | 15      | 6               | $\phi$ B | Red                 | AWG22/19  |
| AWG26         | Black               | LS+      | 8       | 7               | LS+      | Black               | AWG26     |
| AWG26         | Yellow              | LS-      | 14      | 8               | LS-      | Yellow              | AWG26     |
| AWG26         | Blue                | SA       | 12      | 11              | SA       | Blue                | AWG26     |
| AWG26         | Orange              | SB       | 17      | 12              | SB       | Orange              | AWG26     |
| AWG26         | Green               | A+       | 1       | 13              | A+       | Green               | AWG26     |
| AWG26         | Brown               | A-       | 6       | 14              | A-       | Brown               | AWG26     |
| AWG26         | Gray                | B+       | 11      | 15              | B+       | Gray                | AWG26     |
| AWG26         | Red                 | B-       | 16      | 16              | B-       | Red                 | AWG26     |
| AWG26         | Blue                | BK+      | 20      | 9               | BK+      | Blue                | AWG26     |
| AWG26         | Orange              | BK-      | 2       | 10              | BK-      | Orange              | AWG26     |
| AWG26         | Gray                | VCC      | 21      | 17              | VCC      | Gray                | AWG26     |
| AWG26         | Red                 | GND      | 7       | 19              | GND      | Red                 | AWG26     |
| AWG26         | Brown               | VPS      | 18      | 18              | VPS      | Brown               | AWG26     |
| AWG26         | Green               | LS_GND   | 13      | 20              | LS_GND   | Green               | AWG26     |
| -             | -                   | -        | 19      | 22              | -        | -                   | -         |
| AWG26         | Pink                | -        | 22      | 21              | -        | Pink                | AWG26     |
| -             | -                   | -        | 23      | 23              | -        | -                   | -         |
| AWG26         | Black               | FG       | 24      | 24              | FG       | Black               | AWG26     |

(Note) About thickness AWG22/19

The thickness is AWG22 when the cable length is 5m or less, and AWG19 when longer than 5m.

## 2. Installation

### 2.1 Transportation

#### [1] Handling of Robot

When you want to transport the actuator alone, observe the following points.

##### (1) Handling the Packed Unit

Unless otherwise specified, the actuator is shipped with each axis packaged separately.

- Do not damage or drop. The package is not applied with any special treatment that enables it to resist an impact caused by a drop or crash.
- Transport a heavy package with at least more than two operators. Consider an appropriate method for transportation.
- Keep the unit in horizontal orientation when placing it on the ground or transporting. Follow the instruction if there is any for the packaging condition.
- Do not step or sit on the package.
- Do not put any load that may cause a deformation or breakage of the package.

##### (2) Handling the Actuator After Unpacking

- Do not carry an actuator by motor unit and a cable or attempt to move it by pulling the cable.
- Be careful not to bump the actuator into anything when moving it.
- Hold the body base when transporting the actuator.
- Do not apply an excessive force to each part of the actuator.

Supplement) For the names of each part of the actuator, refer to “Names of the Parts”

## [2] Handling in the Assembled Condition

This is the case when the product is delivered from our factory under a condition that it is assembled with other actuators. The combined axes are delivered in a package that the frame is nailed on the lumber base. Fix the table so that would not accidentally move during transportation. The actuators are also fixed so the tip of it would not shake due to the external vibration.

### (1) Handling the Packed Unit

- Do not hit or drop the package. The package is not applied with any special treatment that enables it to resist an impact caused by a drop or crash.
- Do not attempt to carry a heavy package with only one worker. Also, have an appropriate method for transportation.
- When hanging up with ropes, support on the reinforcement frame on the bottom of the lumber base. When bringing up the package with a forklift, also support on the bottom of the lumber base.
- Handle with care when putting the package down to avoid impact or bounce.
- Do not step on the package.
- Do not put any load that may cause a deformation or breakage of the package.

### (2) How to Handle after Unpackaged

- Secure the table to prevent sudden movement during transport.
- If the tip of an actuator is overhanging, have an appropriate way to fix it to avoid shake due to the external vibration. In the transportation without the tip being fixed, do not apply any impact with 0.3G or more.
- When hanging up with ropes, have appropriate cushioning to avoid any deformation of the actuator body. Also keep it in stable horizontal orientation. Make a fixture utilizing the attachment holes and the tapped holes on the actuator body if necessary.
- Do not attempt to apply load on the actuators or the connector box. Also pay attention not to pinch cables and bend or deform them forcefully.

## [3] Handling in Condition of being assembled in Machinery Equipment (System)

These are some caution notes for when transporting the actuator being assembled in the machinery equipment (system):

- Secure the table to prevent sudden movement during transport.
- If the tip of an actuator is overhanging, have an appropriate way to fix it to avoid shake due to the external vibration. In the transportation without the tip being fixed, do not apply any impact with 0.3G or more.
- When hanging up the machinery equipment (system) with ropes, do not attempt to apply load on the actuators or the connector box. Also pay attention not to pinch cables and bend or deform them forcefully.

## 2.2 Installation and Storage • Preservation Environment

### [1] Installation Environment

The actuator should be installed in a location other than those specified below.

In general, the installation environment should be one in which an operator can work without protective gear.

Also provide sufficient work space required for maintenance inspection.

- Where the actuator receives radiant heat from strong heat sources such as heat treatment furnaces
- Where the ambient temperature exceeds the range of 0 to 40°C
- Where the temperature changes rapidly and condensation occurs
- Where the relative humidity exceeds 85% RH
- Where the actuator receives direct sunlight
- Where the actuator is exposed to corrosive or combustible gases
- Where the ambient air contains a large amount of powder dust, salt or iron (at level exceeding what is normally expected in an assembly plant)
- Where the actuator is subject to splashed water, oil (including oil mist or cutting fluid) or chemical solutions
- Where the actuator receives impact or vibration
- Where the altitude is more than 2000m

If the actuator is used in any of the following locations, provide sufficient shielding measures:

- Where noise generates due to static electricity, etc.
- Where the actuator is subject to a strong electric or magnetic field
- Where the actuator is subject to ultraviolet ray or radiation

### [2] Storage • Preservation Environment

- The storage and preservation environment should comply with the same standards as those for the installation environment. In particular, when the machine is to be stored for a long time, pay close attention to environmental conditions so that no dew condensation forms.
- Unless specially specified, moisture absorbency protection is not included in the package when the machine is delivered. In the case that the machine is to be stored and preserved in an environment where dew condensation is anticipated, take the condensation preventive measures from outside of the entire package, or directly after opening the package.
- For storage and preservation temperature, the machine withstands temperatures up to 60°C for a short time, but in the case of the storage and preservation period of 1 month or more, control the temperature to 50°C or less.
- Storage and preservation should be performed in the horizontal condition. In the case it is stored in the packaged condition, follow the posture instruction if any displayed on the package.

## 2.3 How to Install

This chapter explains how to install the actuator on your mechanical system.

### 2.3.1 Installation

Follow the information below when installing the actuator, as a rule. Do pay attention to these items (except with custom-order models).

○ : Possible    △ : Daily inspection is required    × : Not possible

| Model                                      | Horizontal installation | Vertical installation | Sideway installation | Ceiling mount installation |
|--|-------------------------|-----------------------|----------------------|----------------------------|
| TA4C,<br>TA6C, TA7C<br>TA4R,<br>TA6R, TA7R | ○                       | ○                     | ○                    | ○                          |

#### Installation Orientation

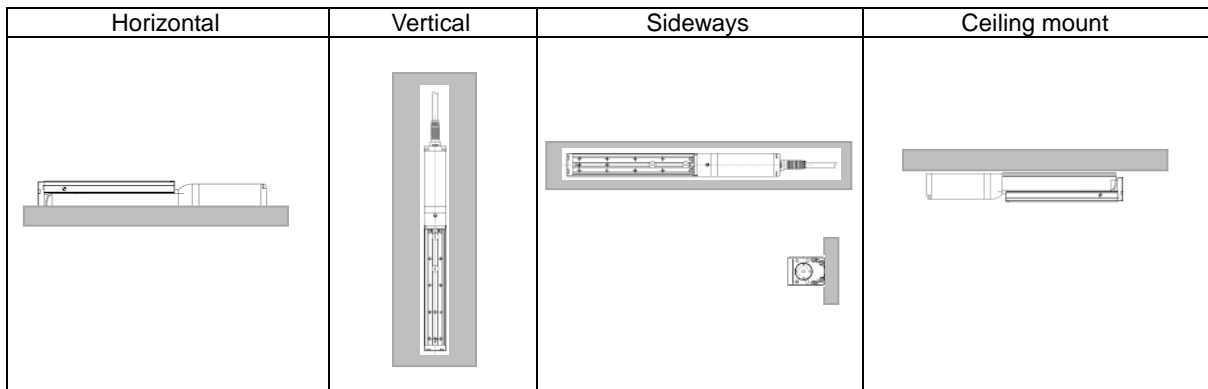

**Caution:** 1. When the unit is installed vertically oriented, Motor straight type is attempt to put the motor up unless there is a special reason. · Putting the motor on the lower side would not cause a problem in an ordinary operation. However, it may rarely cause a problem, when it is not operated for a long period, depending on the surrounding environment (especially high temperature), caused by the grease being separated and the base oil flowing into the

### 2.3.2 Installation of the Main Unit

The surface to mount the main unit should be a machined surface or a plane that possesses an equivalent accuracy and the flatness should be within 0.02mm/m. Also, the platform should have a structure stiff enough to install the unit so it would not generate vibration or other abnormality.

Also consider enough space necessary for maintenance work such as actuator replacement and inspection.

On the rear side of the actuator, there are tapped holes and through holes for attachment and reamed hole and oblong hole for positioning. See the appearance drawings for the details of the position and diameters. [Refer to 5. "External Dimensions"]

Utilize the reamed holes when repeatability in the attachment after detaching is required. However, when small tunings such as the perpendicularity is required, consider such things like to use one reamed hole.

#### [1] Using the Tapped Holes on the Bottom of the Base Frame

This actuator has the tapped holes for mounting so it can be fixed from the bottom of the base. (Note that tapped hole size depends on the model. Please see the diagrams below and 5 "External Dimensions".)

Also, there are reamed holes and a slotted hole for positioning.

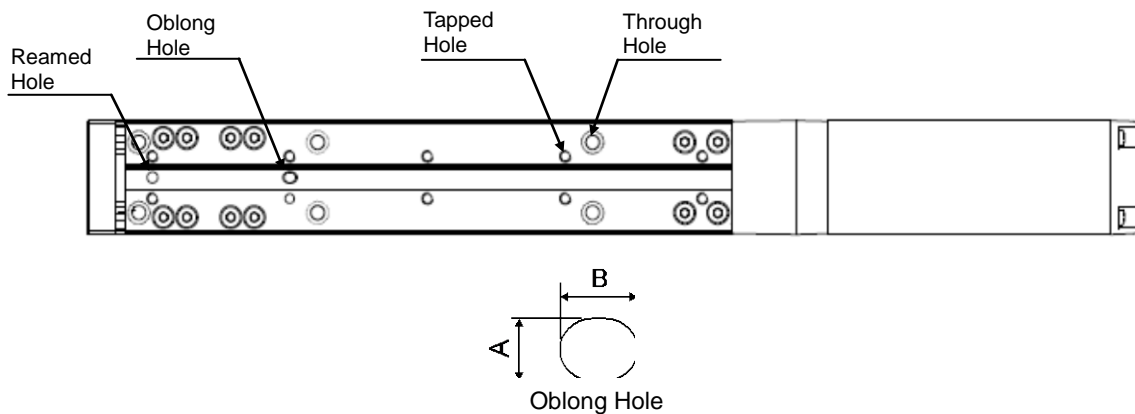

| Model Name   | Tapped Hole Size | Tapped Holes Depth                               | Tightening Torque  |   | Reamed Hole [mm] | Oblong Hole                   |
|--------------|------------------|--|--|---|------------------|-------------------------------|
|              |                  |  | In the case that steel is used for the bolt seating surface: | In the case that aluminum is used for the bolt seating surface: |                  |                               |
| TA4C<br>TA4R | M4               | Through<br>(screwing depth should be 7.5mm max.) | 3.59N·m<br>(0.37kgf·m)                                       | 1.76N·m<br>(0.18kgf·m)  | φ4H7 Depth 4     | A:4H7 B:5 Depth 4.5mm or less |
| TA6C<br>TA6R | M5               | 10mm   | 7.27N·m<br>(0.74kgf·m)                                       | 3.42N·m<br>(0.35kgf·m)  | φ5H7 Depth 5.5   | A:5H7 B:6 Depth 5.5mm or less |
| TA7C<br>TA7R | M6               | 12mm   | 12.34N·m<br>(1.26kgf·m)                                      | 5.36N·m<br>(0.55kgf·m)  | φ6H7 Depth 6     | A:6H7 B:7 Depth 6mm or less   |

## Tightening Screws

- Use hexagonal socket head bolts for the male threads for installing the base.
- Use of high-tension bolts meeting at least ISO 10.9 is recommended.
- The length of thread engagement should be 1.8 times more than the nominal diameter, and pay attention not to stick the screw out inside the actuator for through hole.

 Note: Be careful when selecting the bolt length. If bolts of inappropriate lengths are used, the tapped holes may be damaged, actuator mounting strength may become insufficient, or contact with driving parts may occur, resulting in lower precision or unexpected accidents.

## [2] Using the Through Holes on the Top of the Base Frame

For TA4, TA6, and TA7, there are through holes equipped on the base frame so that the unit can be attached from the top of the base.

(Note) When the stroke is short, the through hole on the front side of TA4R, TA6R, and TA7R cannot be used, since it interferes with the motor.  
[Refer to 5. "External Dimensions"]

It can be installed from the top of the base frame by removing the ball screw cover, as shown in the following procedures,

When the installation is completed, affix the ball screw cover by the reverse order.

When affixing the front cover, tighten the screws with the tightening torque described below.

|                   |
|-------------------|
| Tightening Torque |
| 64.8 N·cm         |

- (1) Pull the table forward as shown in the figure.  
The table cannot be driven only with ROBO Cylinder itself if it is equipped with a brake. Connect a controller and have JOG operation to move the table to perform installation. Or, for Motor Straight Type, detach the motor unit once to move the table for installation, and put the motor unit back on. [Refer to 4.8 "Motor Replacement Process"]
- (2) Remove the front cover and the ball screw cover (made of resin).  
Remove the two bolts and pull forward the front cover.  
Deform the ball screw cover toward inside to remove it.

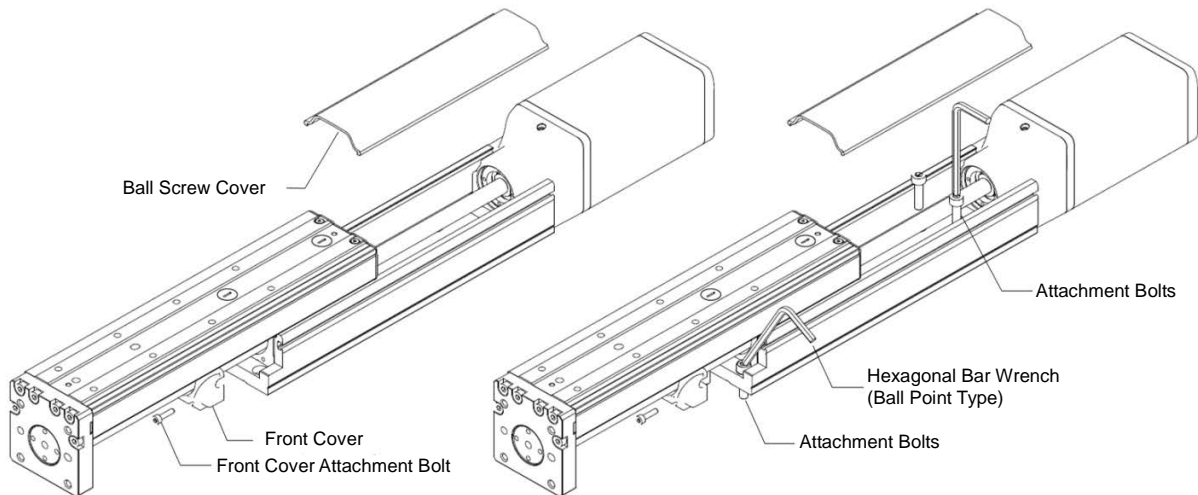

For mounting bolts, use hexagonal socket head bolts indicated in the following table depending on the platform material.

| Model        | Through Hole                                | Mounting Bolt | Tightening Torque      |
|--------------|---|---------------|------------------------|
| TA4C<br>TA4R | φ5 drilled hole, 8 counter boring depth 4   | M4            | 1.76N·m<br>(0.18kgf·m) |
| TA6C<br>TA6R | φ6 drilled hole, 9.5 counter boring depth 5 | M5            | 3.42N·m<br>(0.35kgf·m) |
| TA7C<br>TA7R | φ7 drilled hole, 11 counter boring depth 6  | M6            | 5.36N·m<br>(0.55kgf·m) |

## Tightening Screws

- Use hexagonal socket head bolts for the male threads for installing the base.
- Use of high-tension bolts meeting at least ISO 10.9 is recommended.
- For the effective engagement length between the bolt and female thread, provide at least the applicable value specified below:  
Female thread is made of steel material → Same length as the nominal diameter  
Female thread is made of aluminum → 1.8 times of nominal diameter

 **Caution:** Be careful when selecting the bolt length. If bolts of inappropriate lengths are used, actuator mounting strength may become insufficient, or contact with driving parts may occur, resulting in lower precision or unexpected accidents.

### [3] When Using Attachment Holes on Bracket in Side-Mounted Motor Type

There are tapped holes equipped on the side-mounted bracket. (Refer to the table below for detailed dimensions.)

- For TA4R

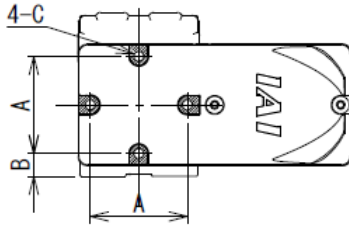

- For TA6R, TA7R

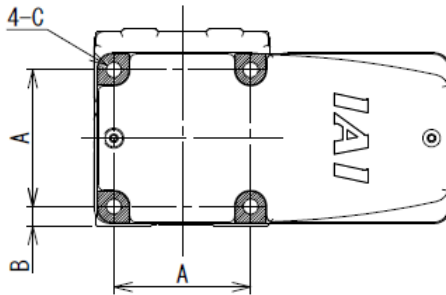

|      | A  | B   |
|------|----|-----|
| TA4R | 32 | 7.5 |
| TA6R | 45 | 6.5 |
| TA7R | 55 | 7.5 |

| Model Name | Attachment Hole Diameter | Attachment Hole Depth | Tightening Torque      |
|------------|--------------------------|-----------------------|------------------------|
| TA4R       | M4                       | 8mm                   | 1.76N·m<br>(0.18kgf·m) |
| TA6R       | M6                       | 12mm                  | 5.4N·m<br>(0.55kgf·m)  |
| TA7R       | M8                       | 16mm                  | 11.5N·m<br>(1.17kgf·m) |

## Tightening Screws

- Use hexagonal socket head bolts for the male threads for installing the base.
- Use of high-tension bolts meeting at least ISO 10.9 is recommended.
- Have the length of thread engagement approximately 1.8 times of the nominal diameter.



Caution: Be careful when selecting the bolt length. If bolts of inappropriate lengths are used, the damage of the attachment hole and actuator mounting strength may become insufficient, or contact with driving parts may occur, resulting in lower precision or unexpected accidents.

**[Precautions for Attachments]**

Pay attention to the following when installation is conducted with using the attachment holes on the side-mounted bracket.

Do not attempt to affix the unit only with the tapped holes on the side-mounted bracket.

Do not apply external force to the main body.

There may be caused vibration due to the operating condition or installation environment, which may result in operational failures or components malfunction.

Availability of installation for each installation posture is as shown below:

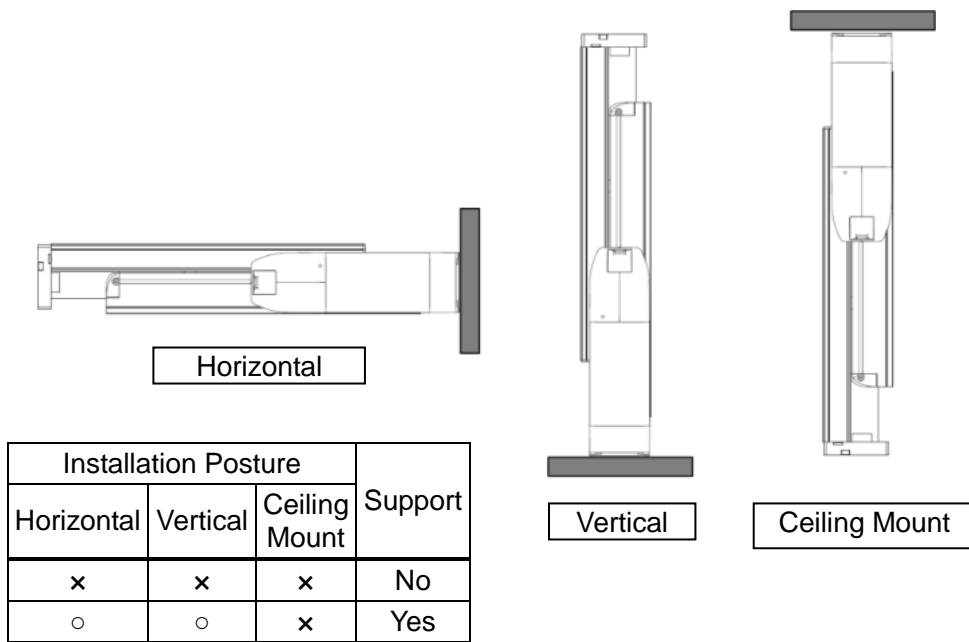

When using the product in horizontal or vertical orientation, have a support block to support the main body to avoid any external force to be applied on the body.

Table motion is blocked when the mounting height, perpendicularity, and position of the support block since it affects center of the actuator axis. Adjust the mounting so that the table moves smoothly.

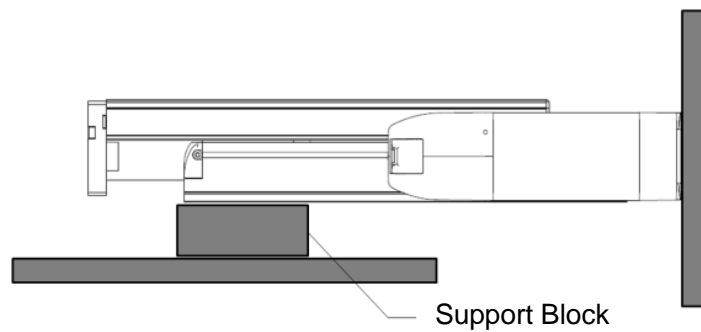

## [4] Attachment of Transported Object

- There are tapped holes on the top surface of the table.
- The way to affix follows the installation of the main unit. Flatness of the mounting surface of transported object should be within 0.020mm as well.
- There are reamed and oblong holes on the top surface of the table. Use these reamed and oblong holes if repeatability of attaching and detaching is required. Also, if small tuning such as perpendicularity is required, use one of the reamed holes for the tuning.
- Refer to the below table for the screwed depth, reamed depth, and oblong depth. Screwing further than indicated in the table may destroy the tapped hole or lower the reinforcement of the attachment of the work part, result in the drop of the accuracy or an unexpected accident.
- Do not fix the perpendicular biplanes of the front plate and the table at the same time. The perpendicularity of the mounted parts may affect the center of the actuator axis, which can lead to operational failures of the table.

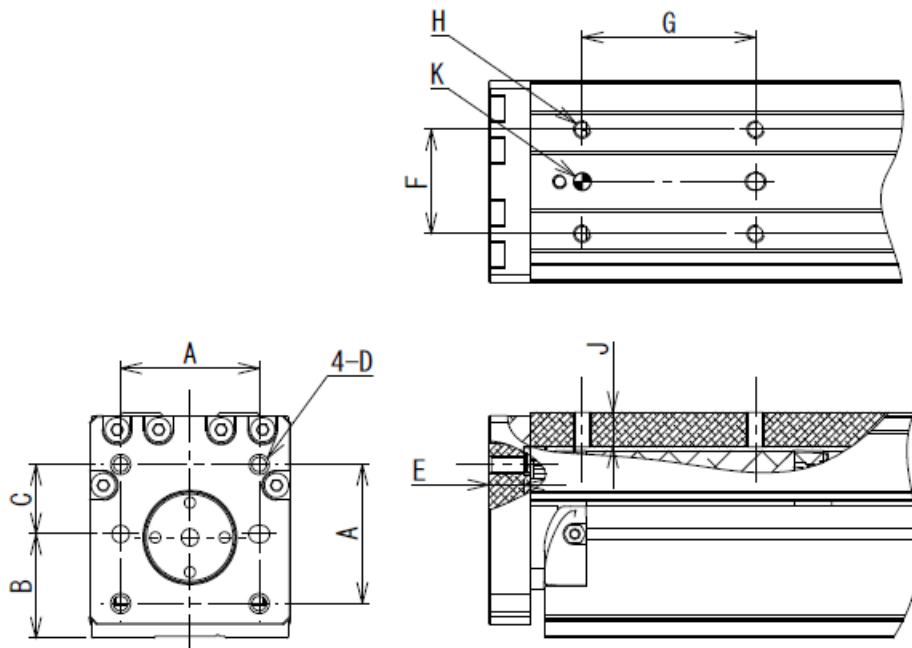

| Model | A  | B  | C  | D  | E          | F  | G  | H  | J          | K              |
|-------|----|----|----|----|------------|----|----|----|------------|----------------|
| TA4   | 30 | 29 | 15 | M4 | 8 or less  | 20 | 50 | M4 | 6 or less  | φ4H7 Depth 4.5 |
| TA6   | 40 | 30 | 20 | M5 | 10 or less | 30 | 50 | M5 | 10 or less | φ5H7 Depth 5.5 |
| TA7   | 50 | 35 | 25 | M6 | 13 or less | 36 | 50 | M6 | 11 or less | φ6H7 Depth 6   |

※ The depth of the positioning pin holes is the distance from the mounting surface

### Tightening Screws

- Use hexagonal socket head bolts for the male threads for installing the base.
- Use of high-tension bolts meeting at least ISO 10.9 is recommended.
- Have the length of thread engagement approximately 1.8 times of the nominal diameter.

⚠ Note: Be careful when selecting the bolt length. Selection of inappropriate length of bolts may cause a breakage of tapped holes or insufficient strength of attachment for transportation.

## 3. Connecting with the Controller

As the connection cable for the controller and the actuator, use the IAI-dedicated connection cable.

- If the dedicated connection cable cannot be secured, reduce the load on the cable by allowing it to deflect only by the weight of the cable or wire it in a self-standing cable hose, etc., having a large radius.
- Do not cut and reconnect the dedicated connection cable for extension or shorten the cable.
- Do not pull on the dedicated connection cable or bend it forcibly.
- The actuator cable coming out of the motor unit is not meant to be bent. Fix the cable so it would not be bent repeatedly

Please consult with IAI if you require a different kind of cable than the one supplied.

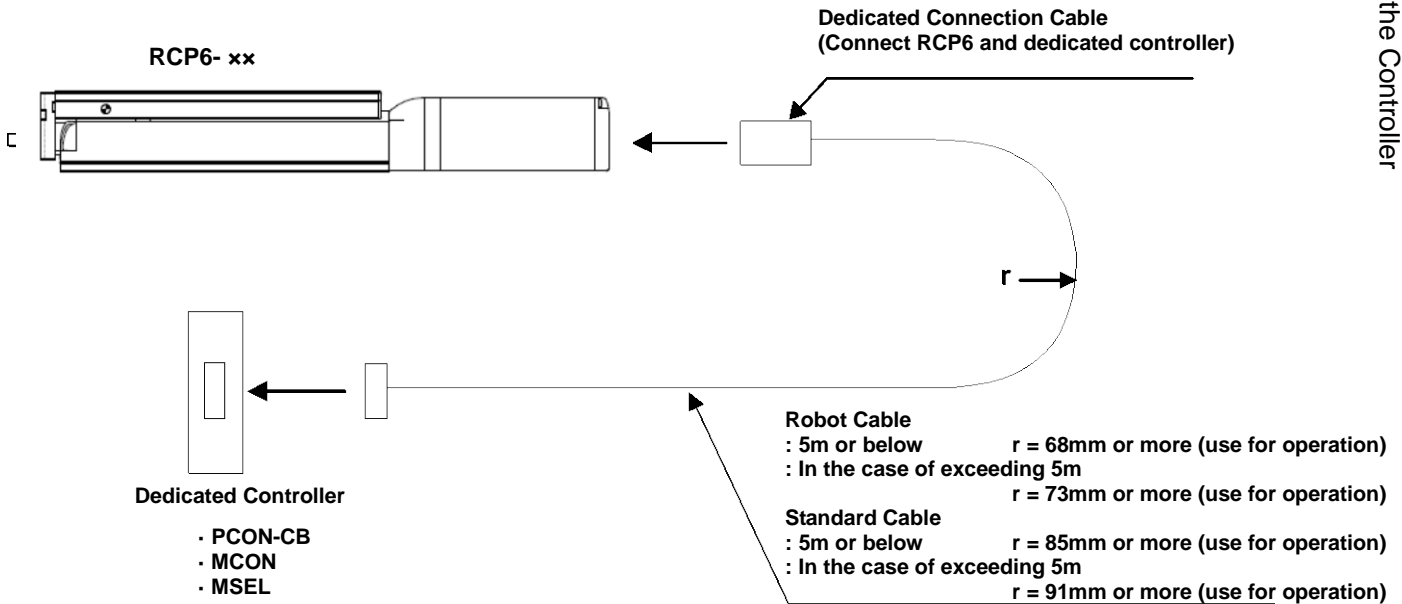

### Dedicated Cable

- Motor Encoder Integrated Cables: CB-CAN-MPA□□□
- Motor Encoder Integrated Robot Cables: CB-CAN-MPA□□□-RB

\*□□□ represents the cable length. The longest corresponds to 20m.  
e.g.) 080 = 8m

**Warning:** For wiring, please follow the warnings stated below. When constructing a system as the machinery equipment, pay attention to the wiring and connection of each cable so they are conducted properly. Not following them may cause not only a malfunction such as cable breakage or connection failure, or an operation error, but also electric shock or electric leakage, or may even cause a fire.

- Use dedicated cables of IAI indicated in this instruction manual. Contact us if you wish to have a change to the specifications of the dedicated cables.
- Make sure to turn the power off in the process of power line or cable connection or disconnection.
- Do not attempt to cut a dedicated cable with connectors on both ends to extend, shorten or re-joint it.
- Hold the dedicated cable to avoid mechanical force being applied to the terminals and connectors.
- Use a cable pipe or duct to have an appropriate protection when there is a possibility of mechanical damage on a dedicated cable.
- In case a dedicated cable is to be used at a moving part, make sure to lay out the cable without applying any force to pull the connector or extreme bend on the cable. Do not attempt to use the cable with a bending radius below the allowable value.
- Make certain that the connectors are plugged properly. Insufficient connection may cause an operation error, thus it is extremely risky.
- Do not lay out the cables to where the machine runs over them.
- Pay attention to the cable layout so it would not hit peripherals during an operation. In case it does, have an appropriate protection such as a cable track.
- When a cable is used hanging on the ceiling, prevent an environment that the cable swings with acceleration or wind velocity.
- Make sure there is not too much friction inside the cable storage equipment.
- Do not apply radiated heat to power line or cables.
- Do not bend the cable in the area from the connector tip inward to 150mm on both ends.  
 Motor • Encoder Integrated Cables CB-CAN-MPA□□□  
 Motor • Encoder Integrated Cables Robot Type CB-CAN-MPA□□□-RB

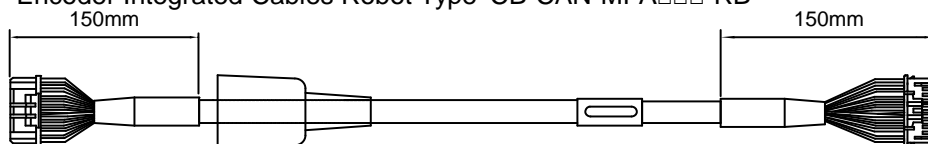

- Have a sufficient radius for bending, and avoid a bend concentrating on one point.

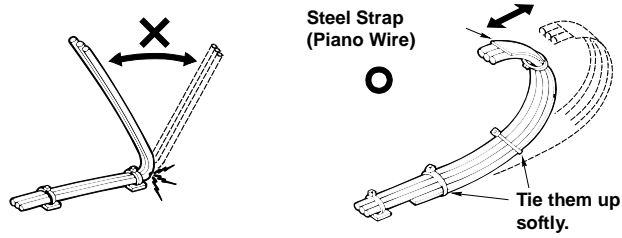

- Do not let the cable bend, kink or twist.

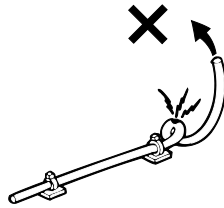

- Do not pull the cable with a strong force.

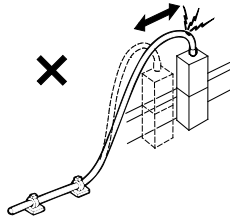

- Pay attention not to concentrate the twisting force to one point on a cable.

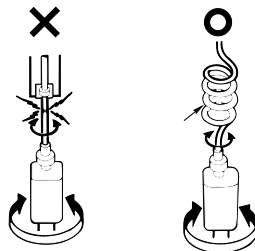

- Do not pinch, drop a heavy object onto or cut the cable.

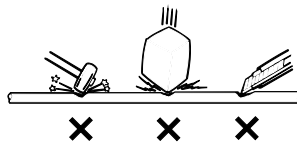

- When a cable is fastened to affix, make sure to have an appropriate force and do not tighten too much.

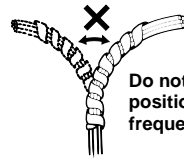
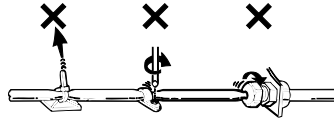

Do not use spiral tube in any position where cables are bent frequently.

- PIO line, communication line, power and driving lines are to be put separately from each other and do not tie them together. Arrange so that such lines are independently routed in the duct.

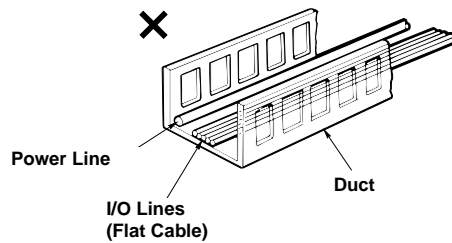

Follow the instructions below when using a cable track.

- If there is an indication to the cable for the space factor in a cable track, refer to the wiring instruction given by the supplier when storing the cable in the cable track.
- Avoid the cables to get twined or twisted in the cable track, and also to have the cables move freely and do not tie them up. (Avoid tension being applied when the cables are bent.) Do not pile up cables. It may cause faster abrasion of the sheaths or cable breakage.

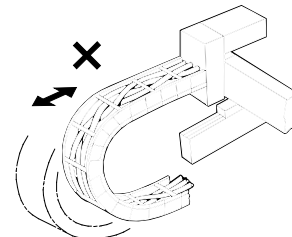
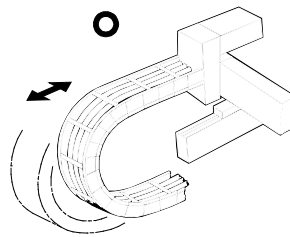
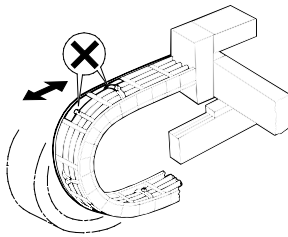

## 4. Maintenance and Inspection

### 4.1 Inspection Items and Schedule

Follow the maintenance inspection schedule below.

It is assumed that the equipment is operating 8 hours per day.

If the equipment is running continuously night and day or otherwise running at a high operating rate, inspect more often as needed.

| Period of Time                    | External Visual Inspection | Internal Inspection   | Greasing <sup>(Note 1)</sup>                |
|-----------------------------------|----------------------------|-----------------------|---|
| Start of work inspection          | ○                          |                       |   |
| 1 month inspection                | ○                          |                       |   |
| 3 month inspection                |                            |                       | ○   |
| 3 months after starting operation |                            |                       | Depends on grease supply timing (reference) |
| 6 month inspection                | ○                          | ○ <sup>(Note 2)</sup> |   |
| Every 6 months thereafter         | ○                          | ○ <sup>(Note 2)</sup> |   |

Note 1 Grease film may run out if the actuator is moved back and forth continuously over a distance of 30 mm or less. As a guide, perform a back-and-forth operation five times or so over a distance of 50 mm or more after a back-and-forth operation over such short distance has been repeated 5,000 to 10,000 times. This will restore oil film.

Note 2 Check the condition of grease, and wipe off the grease before supplying new in case it is extremely dirty.

#### [Grease Supply Timing (Reference)]

Perform grease supply when it has reached to either the operation distance or spent months described in the table below.

| Maximum Speed of Use [mm/s] | Grease Supply Timing (Reference) |          |
|-----------------------------|----------------------------------|----------|
|                             | Operated distance                | Months   |
| 0 to 750 or less            | 1,250km                          | 12 month |
| 750 to 1120                 | 2,500km                          |          |

⚠ Caution: • An actuator after 6 months of storage may have caused a degradation of the grease.  
Supply grease before start using. [Refer to 4.6 "Grease Supply"]

- Degradation speed of grease may differ depending on the environment of use (temperature, humidity and ambient conditions). It is recommended to shorten the grease supply period if the actuator is used under a bad condition such as in high temperature, high humidity or in dusty ambience. Also, it is recommended to improve the environment conditions in case the grease changes its color due to the bad condition of use.

## 4.2 External Visual Inspection

An external visual inspection should check the following things.

|           |   |
|-----------|---|
| Main unit | Loose actuator mounting bolts,<br>other loose items |
| Cables    | Scratches, proper connections                       |
| Overall   | Irregular noise, vibration                          |

- When the actuator is vertically fixed, the grease applied to the guide may drip depending on the environment. Do appropriate cleaning and supply of grease.

## 4.3 Cleaning

- Clean exterior surfaces as necessary.
- Use a soft cloth to wipe away dirt and buildup.
- Do not blow too hard with compressed air as it may cause dust to get in through the gaps.
- Do not use oil-based solvents as they can harm lacquered and painted surfaces.
- To remove severe buildup, wipe gently with a soft cloth soaked in a neutral detergent or alcohol.

## 4.4 Internal Inspections

Turn OFF the power, remove the ball screw cover and have a visual inspection. When inspecting the interior, check the following items.

|               |   |
|---------------|---|
| Actuator      | Loose mounting bolts, other loose items |
| Guide section | Lubrication, buildup                    |

Visually inspect the interior of the equipment. Check whether dust or other foreign matter has gotten inside and check the lubrication state.

The lubrication may have turned brown. This is not a problem as long as the travel surfaces shine as though they are wet.

If the grease is mixed with dust and does not have a shiny appearance, or if the grease has lost its efficacy due to prolonged use, then clean each section and reapply grease.

The procedure for internal inspections is outlined below.

- (1) Pull the table forward as shown in the figure.  
The table cannot be driven only with ROBO Cylinder itself if it is equipped with a brake. Connect a controller and have JOG operation to move the table to perform installation. Or, for Motor Straight Type, detach the motor unit once to move the table for installation, and put the motor unit back on. [Refer to 4.8 "Motor Replacement Process"]
- (2) Remove the ball screw cover (made of resin).  
Deform the ball screw cover toward inside to remove it.

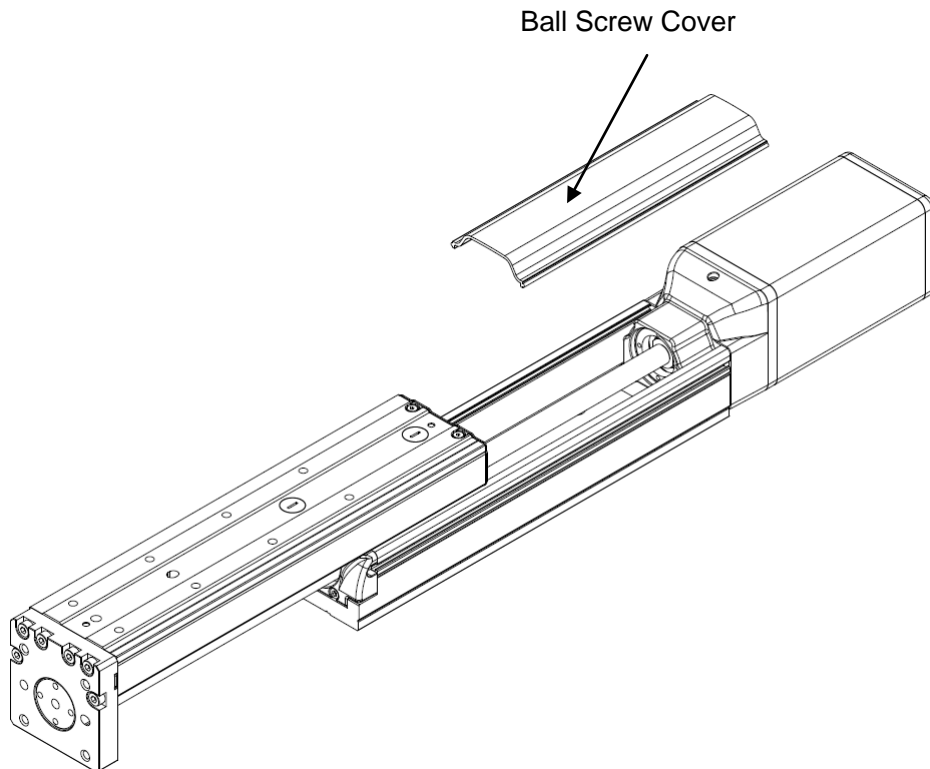

- (3) Check inside.
- (4) After finishing the inspection, assemble back in the reverse order.

## 4.5 Internal Cleaning

- Use a soft cloth to wipe away dirt and buildup.
- Do not blow too hard with compressed air as it may cause dust to get in through the gaps.
- Do not use oil-based solvents, neutral detergent or alcohol.

## 4.6 Grease Supply

### 4.6.1 Standard Type Grease to Use

IAI uses the following grease in our plant.

|                     |                |                 |
|---------------------|----------------|-----------------|
| Guide<br>Ball Screw | Kyodo<br>Yushi | Multitemp LRL 3 |
|---------------------|----------------|-----------------|

**⚠ Warning:** Never use anything other than synthetic poly-olefin grease. Mixing poly-grease with other grease not only reduces the performance of the grease, it may even cause damage to the actuator.

### 4.6.2 How to Apply Grease

- (1) Grease the ball screw  
 With the table fully extended, remove the ball screw cover by the procedure described in "Internal Inspections". Wipe the grease off the ball screw surface.  
 Apply the grease to ball screw directly by hand.  
 Wipe off excess grease.
- (2) Grease the guide part  
 With the table fully extended, remove the hole cap from the table.  
 Insert the grease nozzle into the hole and apply the grease.  
 Move the table several times to rub the grease.  
 Wipe off excess grease.

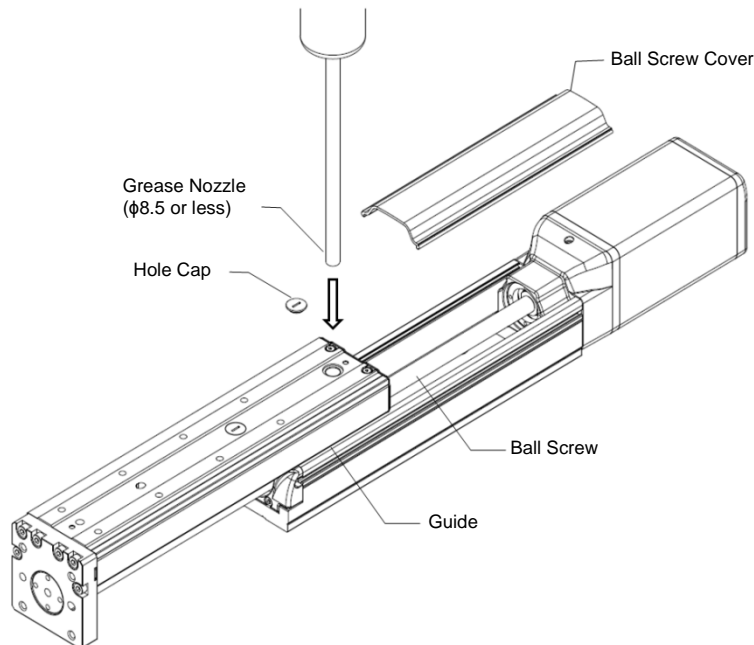

**⚠ Caution:** Supplying too much grease may increase sliding resistance and load to the motor, resulting in a drop of performance.

## 4.7 Procedure for Belt Replacement and Tuning

Application : TA4R, TA6R, TA7R

### 4.7.1 Inspection of the Belt

For inspection work, detach the pulley cover with hexagonal wrench and carry it out by visual. Remove two hexagonal socket button head bolts for TA4R, TA6R, and TA7R (where marked with a circle).

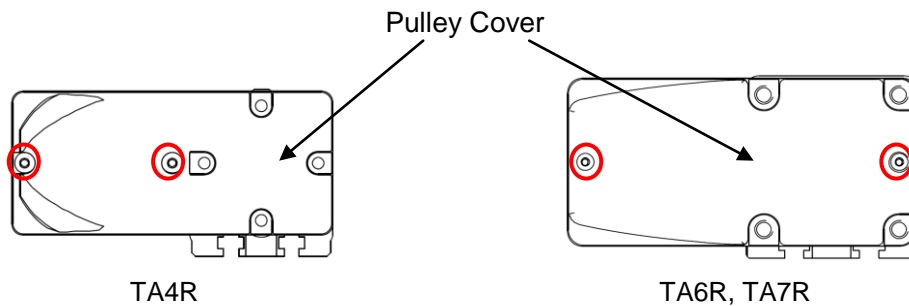

The period of replacement for the belt cannot be clearly defined as the durability of it is impacted so much by the operational conditions.

In generally speaking, it possesses bending life of several million times.

The timing belt gets worn away as the time passes, and it is necessary to have replacement at regular intervals with the following conditions as reference.

- When the gear and belt area show obvious friction.

- When swelling occurs as a result of oil adhesion.

- When damages such as a crack occurs on the belt gear and back side.

Also, for the toothed belt, it is recommended to set the interval of regular replacement cycle when in use under high wire fatigue condition in high acceleration and deceleration because it is difficult to judge the right timing for replacement by checking appearance or looseness of the wires strengthening the belt.

### 4.7.2 Belt to Use

IAI uses the following belt in our plant

| Model | IAI Maintenance Part Code | Manufacturer Model Code |  |
|-------|---------------------------|-------------------------|--|
| TA4R  | TB-RCP6-STRA4R            | 60S2M148 GB             | Rubber, Super torque G Bareback specification<br>(Mitsuboshi Belting Ltd.) |
| TA6R  | TB-RCP6-STRA6R            | 60S2M182 GB             | Rubber, Super torque G Bareback specification<br>(Mitsuboshi Belting Ltd.) |
| TA7R  | TB-RCP6-STRA7R            | 100S3M225 GB            | Rubber, Super torque G Bareback specification<br>(Mitsuboshi Belting Ltd.) |



- 4) Loosen the bolts (where marked with a circle; two bolts for TA4R and TA6R, four bolts for TA7R) holding the motor with a 2.5mm-sized (TA4R) or 3mm-sized (TA6R/TA7R) hexagonal wrench.  
Replace the belt if it is necessary.

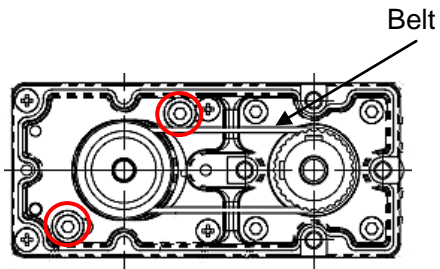

TA4R

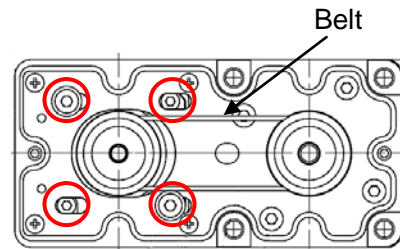

TA6R, TA7R

- 5) Adjust the belt tension.  
 Hand a cable band (thin string) on the edge of the motor unit and pull it on a tension gauge with the specified load (specified value of the belt tension).  
 When the load reached the specified, tighten the bolts (where marked with a circle) with a 2.5mm-sized (TA4R) or 3mm-sized (TA6R/TA7R) hexagonal wrench to hold the unit in the place.

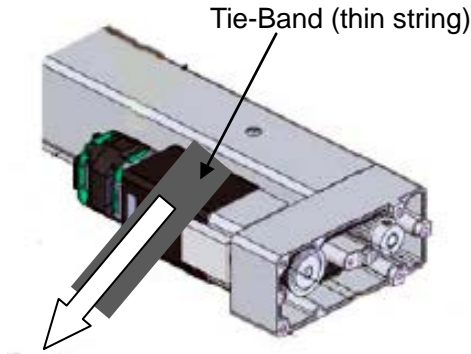

| Model | Tension Force |
|-------|---------------|
| TA4R  | 20 to 25N     |
| TA6R  | 25 to 30N     |
| TA7R  | 80 to 90N     |

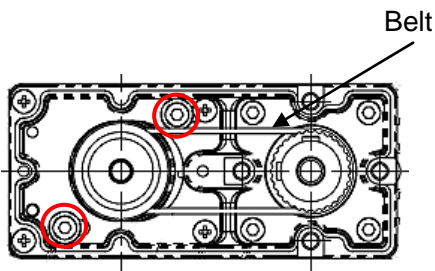

TA4R

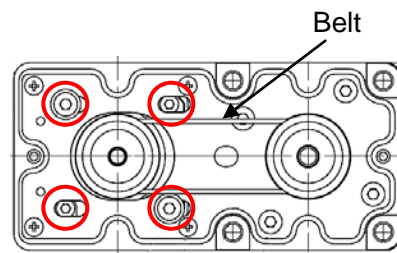

TA6R, TA7R

| Model | Tightening Torque |
|-------|-------------------|
| TA4R  | 162N·cm           |
| TA6R  | 323N·cm           |
| TA7R  | 323N·cm           |

- 6) After tension adjustment of the belt, tighten the following bolts and circular washers attached for position repeatability of the motor in close contact with the motor bracket with 2.5mm-sized hexagonal wrench.

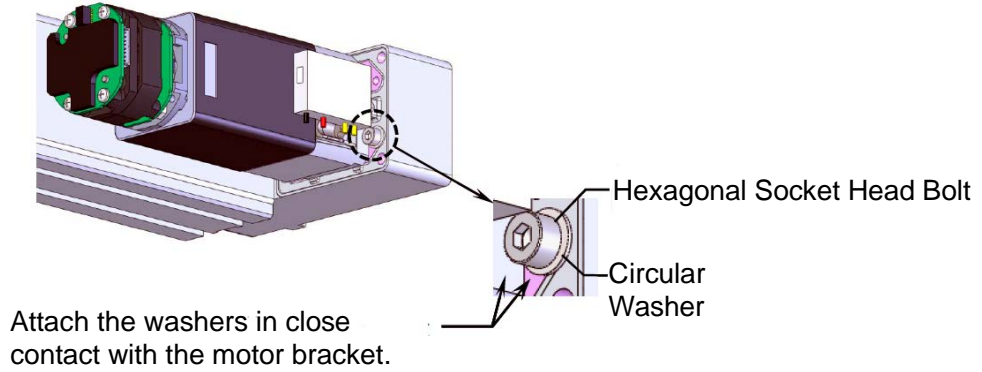

|                   |
|-------------------|
| Tightening Torque |
| 88.7N·cm          |

- 7) Attach the motor cover with four Phillips screws and tighten them with Phillips screwdriver.

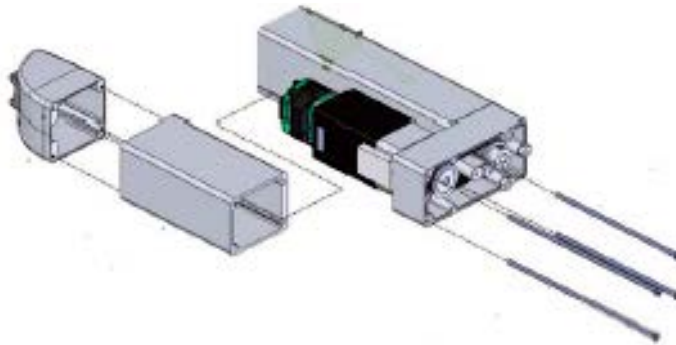

|                  |                   |
|------------------|-------------------|
| Model            | Tightening Torque |
| TA4R, TA6R, TA7R | 41.4N·cm          |

- 8) Attach the pulley cover with two hexagonal socket flat-head bolts for TA4R, TA6R, and TA7R (where marked with a circle) and tighten with a hexagonal wrench.

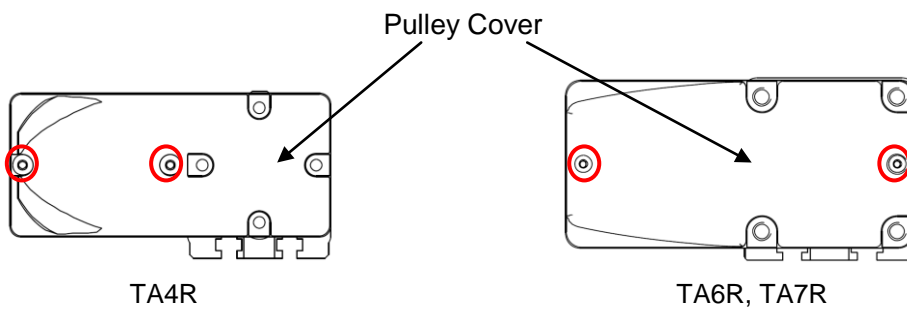

|                   |
|-------------------|
| Tightening Torque |
| 47.9N·cm          |

## 4.8 Motor Replacement Process

 **Caution:** The encoder part of the motor for replacement and the control board of RCP6S may fail due to static electricity. Please be sure to follow the following precautions during work.

- Do not touch the encoder part of the motor for replacement directly with hands.
- Do not touch the control board directly with hands except when replacing the control board of RCP6S.
- Before replacement work, touch metal objects and the like to release any static electricity from body.
- Do not perform replacement work at the place where static electricity is likely to occur (carpet, etc).

### 4.8.1 TA4C, TA6C, TA7C

[Items required for replacing the motor]

- Motor Unit for Replacement

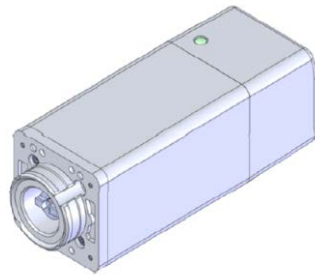

For RCP6

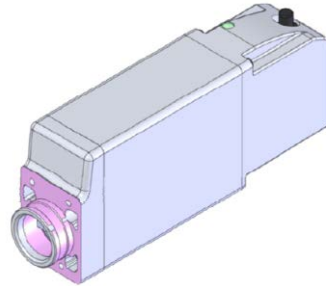

For RCP6S

- Hexagonal wrench set 2mm or 2.5mm-sized

[Procedure]

- 1) Remove the fixing screw affixing the actuator and the motor unit with a 2mm-sized (TA4C, TA6C) or 2.5mm-sized (TA7C) hexagonal wrench.
- 2) Detach the motor unit.

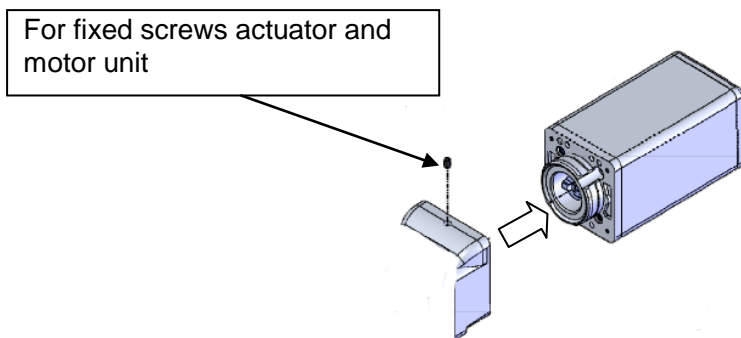

- 3) Make the profiles on the actuator side and motor unit side aligned so the projection matches to the slit.

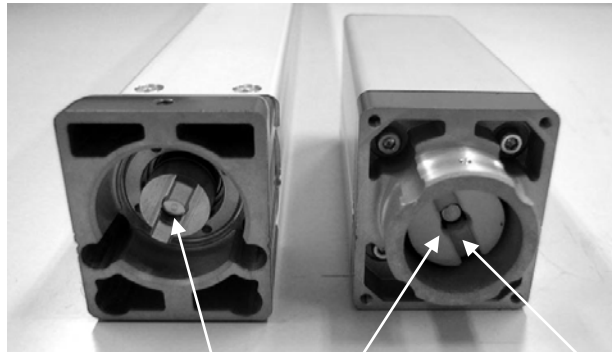

Make the projection and slit matched with each other.

Apply grease to the coupling part. NOXLUB TL1010 grease made by NOK

- 4) Attach the motor unit for replacement with the projection being matched with the slit.
- 5) Tighten the fixing screw to affixing the motor unit to the actuator with 2mm-sized (TA4C, TA6C) or 2.5mm-sized (TA7C) hexagonal wrench.

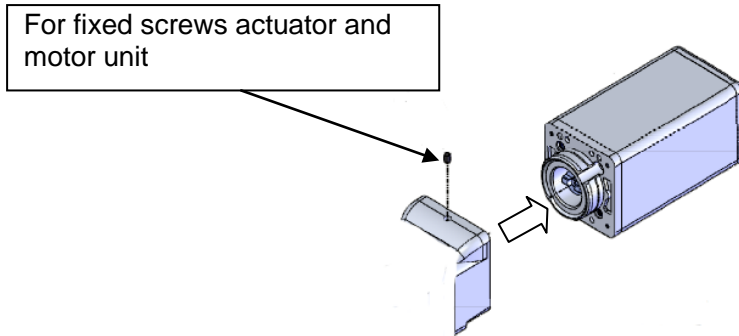

| Model      | Tightening Torque |
|------------|-------------------|
| TA4C, TA6C | 167N·cm           |
| TA7C       | 353N·cm           |

- 6) Make sure to conduct a home return on a PC or a touch panel teaching after motor replacement.

## 4.8.2 TA4R, TA6R, TA7R

[Items required for replacing the motor]

- Motor unit for replacement

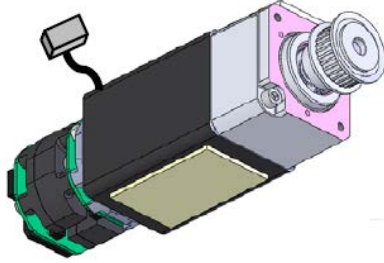

- Hexagon wrench set 2.5mm(TA4R), 3mm(TA6R/TA7R)  
2mm (for hexagonal socket bolt)
- Phillips screwdriver
- Tension gauge (capable thing of tensioning to 90N or greater)
- Strong string or long tie-band

[Procedure]

- 1) Remove two hexagonal socket flat-head bolts for TA4R, TA6R, and TA7R (where marked with a circle) with a hexagonal wrench. Detach the pulley cover.

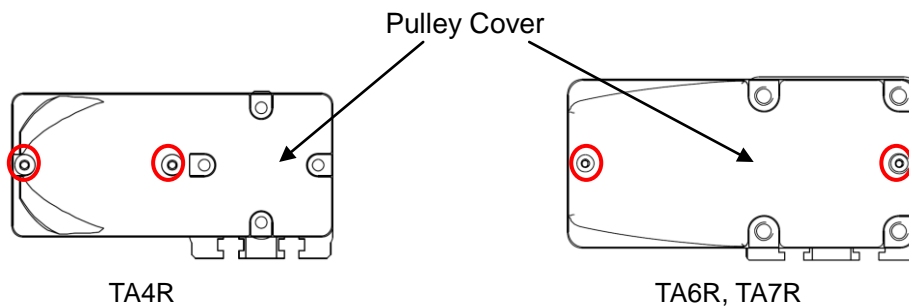

- 2) Remove the four Phillips screws by Phillips screwdriver and remove the motor cover.

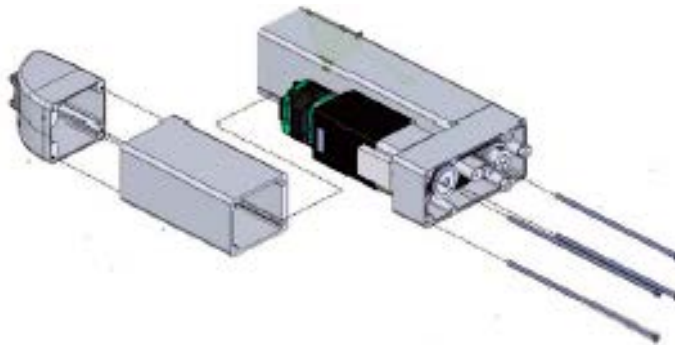

- 3) If the belt is to be replaced at the same time, remove the following bolts and circular washers that are mounted for position repeatability of the motor by 2.5mm-sized hexagonal wrench, after tension adjustment of the belt,

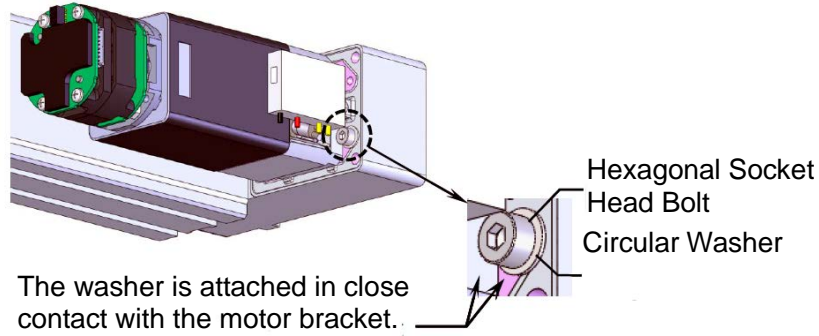

- 4) Loosen the bolts (where marked with a circle; two bolts for TA4R, four bolts for TA6R and TA7R) holding the motor with a 2.5mm-sized (TA4R) or 3mm-sized (TA6R/TA7R) hexagonal wrench. Replace the belt if it is necessary.

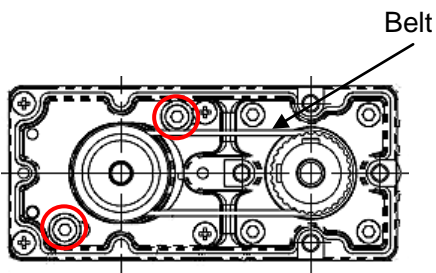

TA4R

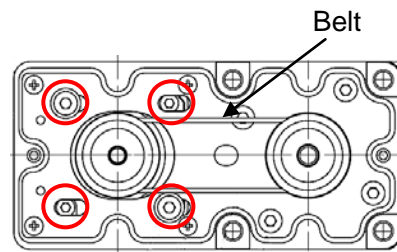

TA6R, TA7R

- 5) Detach the belt off the pulleys.
- 6) Pull out four bolts and remove the motor unit.

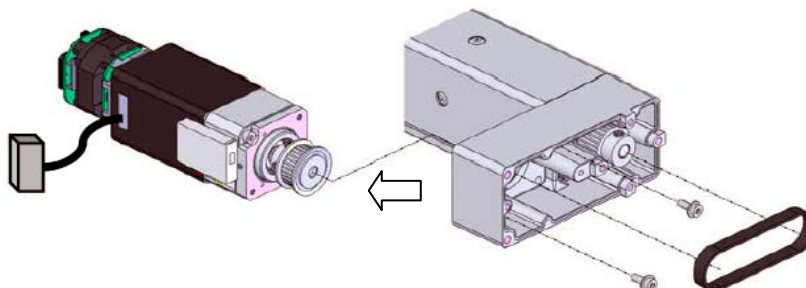

- 7) Install the new motor and temporarily tighten the tension adjustment bolts (encircled parts). Hang the timing belt.

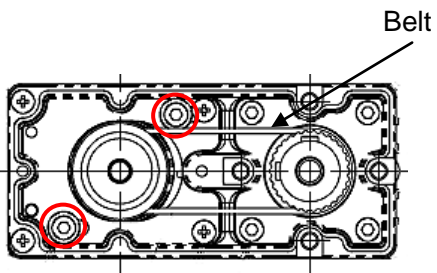
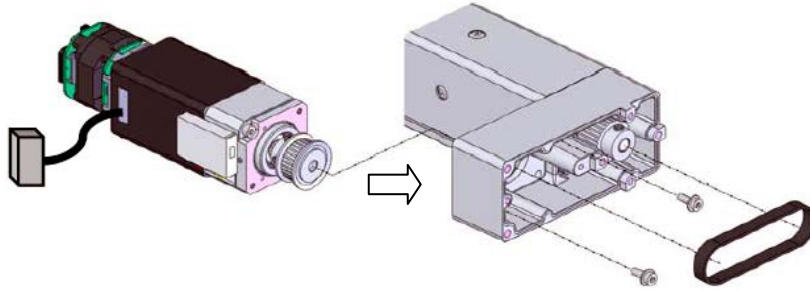

TA4R

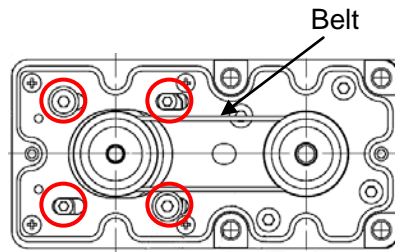

TA6R, TA7R

(Note) If the belt is not replaced at the same time and the following hexagonal socket bolts and circular washers are not removed, there is no need to adjust tension of the belt as prescribed in 8).

Hand a cable band (thin string) on the edge of the motor unit and pull it. When it is abutting against the hexagonal socket bolt, tighten the bolt (where marked with a circle) with 2.5mm-sized (TA4R) or 3mm-sized (TA6R/TA7R) hexagonal wrench to hold the unit in the place.

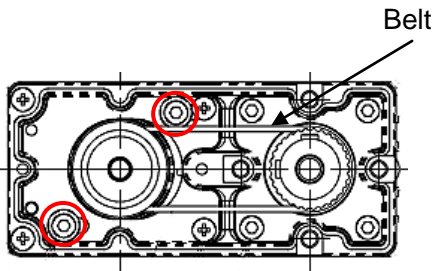
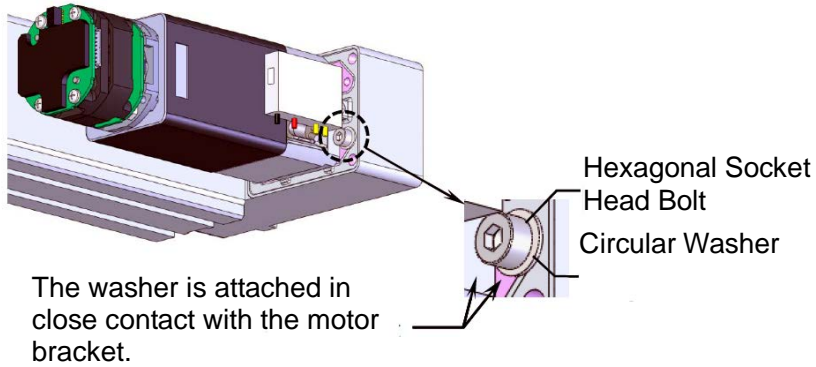

TA4R

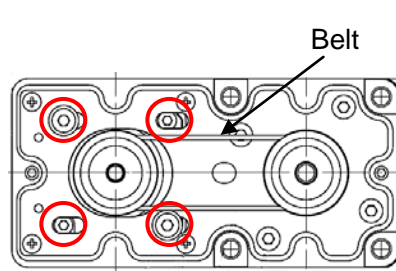

TA6R, TA7R

| Model | Tightening Torque |
|-------|-------------------|
| TA4R  | 162N cm           |
| TA6R  | 323N cm           |
| TA7R  | 323N cm           |

- 8) If the belt has been replaced at the same time, adjust the tension of the belt.  
 Hand a cable band (thin string) on the edge of the motor unit and pull it on a tension gauge with the specified load (specified value of the belt tension).  
 When the load reached the specified, tighten the bolts (where marked with a circle) with a 2.5mm-sized (TA4R) or 3mm-sized (TA6R/TA7R) hexagonal wrench to hold the unit in the place.

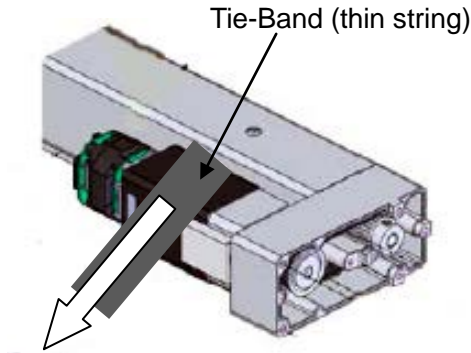

| Model | Tension Force |
|-------|---------------|
| TA4R  | 20 to 25N     |
| TA6R  | 25 to 30N     |
| TA7R  | 80 to 90N     |

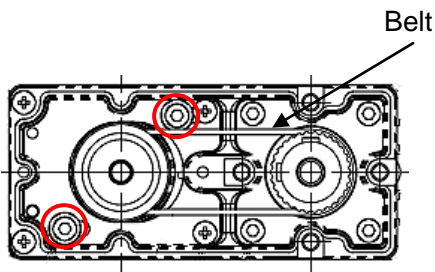

TA4R

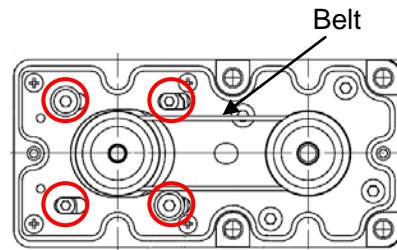

TA6R, TA7R

| Model | Tightening Torque |
|-------|-------------------|
| TA4R  | 162N cm           |
| TA6R  | 323N cm           |
| TA7R  | 323N cm           |

- 9) If the belt has been replaced at the same time, tighten the following bolts and circular washers that are mounted for position repeatability of the motor with 2.5-mm sized hexagonal wrench after tension adjustment of the belt.

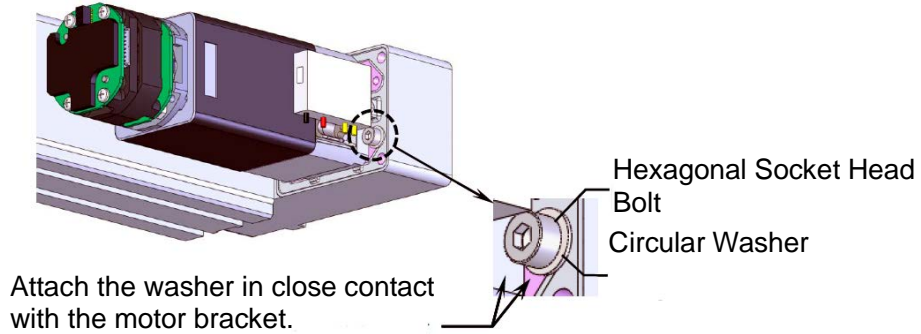

|                   |
|-------------------|
| Tightening Torque |
| 88.7N·cm          |

- 10) Attach the motor cover with four Phillips screws and tighten them with Phillips screwdriver.

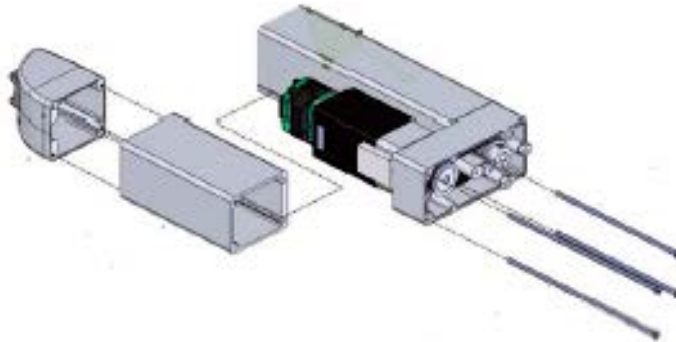

|                  |                   |
|------------------|-------------------|
| Model            | Tightening Torque |
| TA4R, TA6R, TA7R | 41.4N·cm          |

- 11) Attach the pulley cover with two hexagonal socket flat-head bolts for TA4R, TA6R, and TA7R (where marked with a circle) and tighten with a hexagonal wrench.

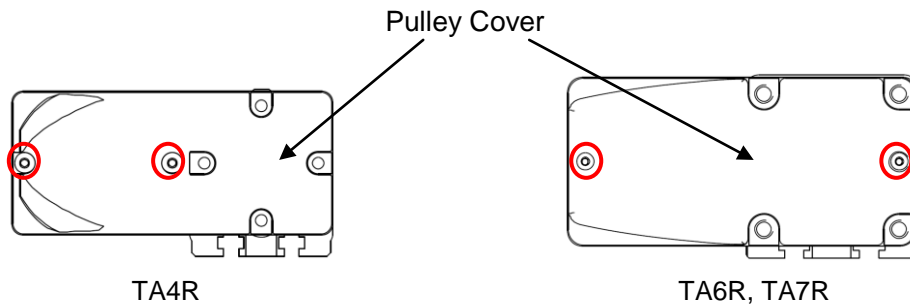

|                   |
|-------------------|
| Tightening Torque |
| 47.9N·cm          |

- 12) Make sure to conduct a home return on a PC or a touch panel teaching after motor replacement.

## 5. External Dimensions

### 5.1 Standard Specification RCP6-TA4C

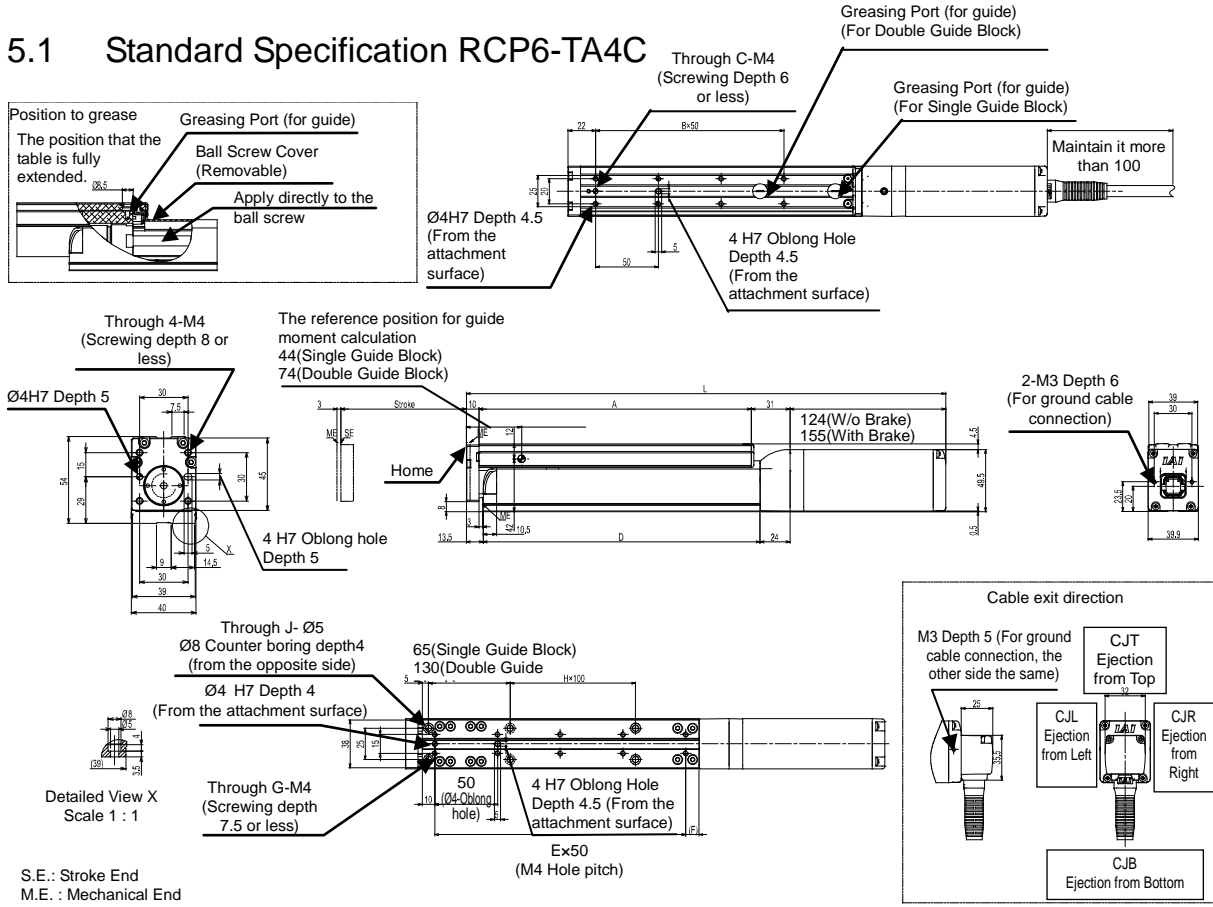

#### Standard Specification (Single Guide Block)

| Stroke | L         |            | A   | B | C | D     | E | F    | G  | H | J | Mass [kg] |            |
|--------|-----------|------------|-----|---|---|-------|---|------|----|---|---|-----------|------------|
|        | W/o Brake | With Brake |     |   |   |       |   |      |    |   |   | W/o Brake | With Brake |
| 25     | 257       | 288        | 92  | 1 | 4 | 95.5  | 1 | 35.5 | 4  | 0 | 4 | 1.2       | 1.4        |
| 50     | 282       | 313        | 117 | 1 | 4 | 120.5 | 2 | 10.5 | 6  | 0 | 4 | 1.3       | 1.4        |
| 75     | 307       | 338        | 142 | 2 | 6 | 145.5 | 2 | 35.5 | 6  | 0 | 4 | 1.4       | 1.5        |
| 100    | 332       | 363        | 167 | 2 | 6 | 170.5 | 3 | 10.5 | 8  | 0 | 4 | 1.5       | 1.6        |
| 125    | 357       | 388        | 192 | 3 | 8 | 195.5 | 3 | 35.5 | 8  | 1 | 6 | 1.6       | 1.7        |
| 150    | 382       | 413        | 217 | 3 | 8 | 220.5 | 4 | 10.5 | 10 | 1 | 6 | 1.6       | 1.8        |

#### Double Guide Block

| Stroke | L         |            | A   | B | C  | D     | E | F    | G  | H | J | Mass [kg] |            |
|--------|-----------|------------|-----|---|----|-------|---|------|----|---|---|-----------|------------|
|        | W/o Brake | With Brake |     |   |    |       |   |      |    |   |   | W/o Brake | With Brake |
| 40     | 332       | 363        | 167 | 2 | 6  | 170.5 | 3 | 10.5 | 8  | 0 | 4 | 1.5       | 1.7        |
| 65     | 357       | 388        | 192 | 3 | 8  | 195.5 | 3 | 35.5 | 8  | 0 | 4 | 1.6       | 1.8        |
| 90     | 382       | 413        | 217 | 3 | 8  | 220.5 | 4 | 10.5 | 10 | 0 | 4 | 1.7       | 1.9        |
| 140    | 432       | 463        | 267 | 4 | 10 | 270.5 | 5 | 10.5 | 12 | 1 | 6 | 1.9       | 2.0        |
| 190    | 482       | 513        | 317 | 5 | 12 | 320.5 | 6 | 10.5 | 14 | 1 | 6 | 2.1       | 2.2        |
| 240    | 532       | 563        | 367 | 6 | 14 | 370.5 | 7 | 10.5 | 16 | 2 | 8 | 2.2       | 2.4        |

(Note) L dimensions described in the table are those with no cable ejection direction (option). For cable ejection direction types (option), the dimensions are longer in 25mm.

## 5.2 Built-in Controller Specification RCP6S-TA4C

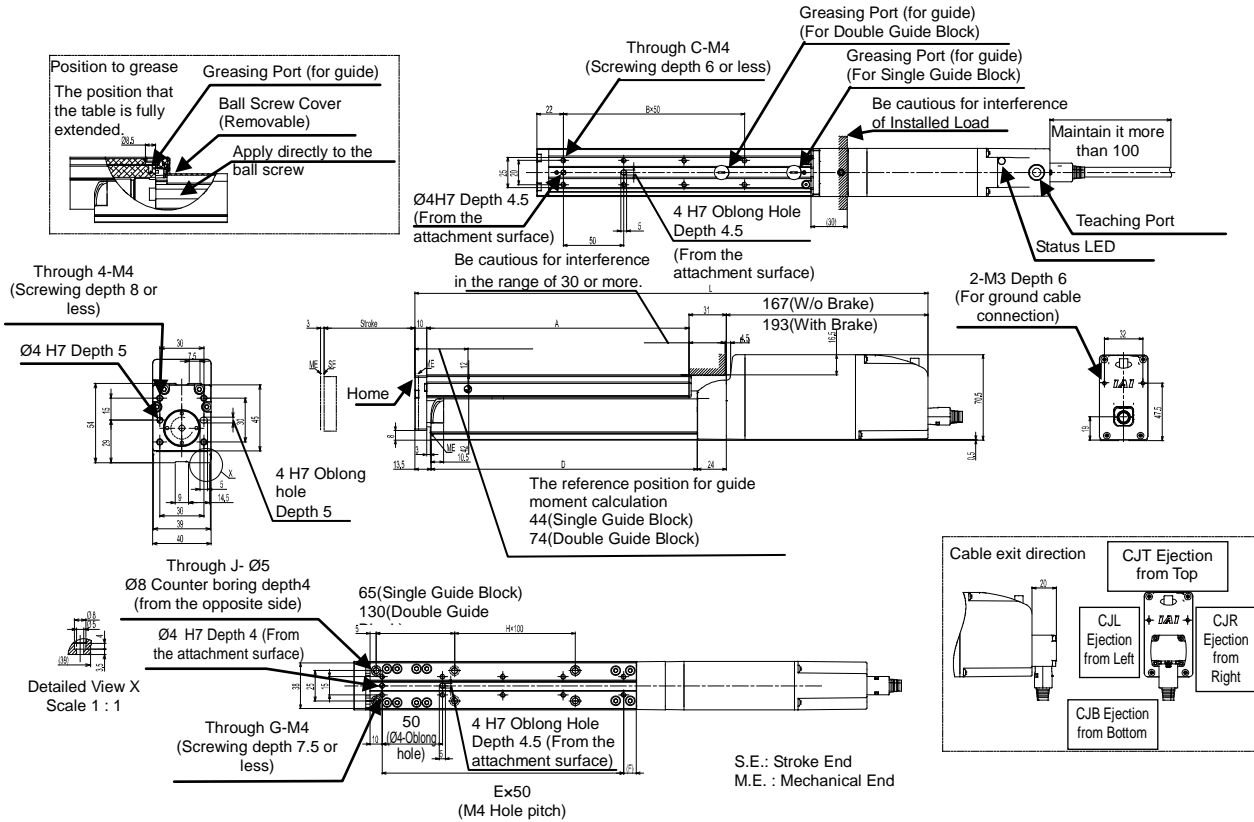

### Standard Specification (Single Guide Block)

| Stroke | L         |            | A   | B | C | D     | E | F    | G  | H | J | Mass [kg] |            |
|--------|-----------|------------|-----|---|---|-------|---|------|----|---|---|-----------|------------|
|        | W/o Brake | With Brake |     |   |   |       |   |      |    |   |   | W/o Brake | With Brake |
| 25     | 300       | 326        | 92  | 1 | 4 | 95.5  | 1 | 35.5 | 4  | 0 | 4 | 1.4       | 1.5        |
| 50     | 325       | 351        | 117 | 1 | 4 | 120.5 | 2 | 10.5 | 6  | 0 | 4 | 1.5       | 1.6        |
| 75     | 350       | 376        | 142 | 2 | 6 | 145.5 | 2 | 35.5 | 6  | 0 | 4 | 1.6       | 1.7        |
| 100    | 375       | 401        | 167 | 2 | 6 | 170.5 | 3 | 10.5 | 8  | 0 | 4 | 1.7       | 1.8        |
| 125    | 400       | 426        | 192 | 3 | 8 | 195.5 | 3 | 35.5 | 8  | 1 | 6 | 1.7       | 1.9        |
| 150    | 425       | 451        | 217 | 3 | 8 | 220.5 | 4 | 10.5 | 10 | 1 | 6 | 1.8       | 2.0        |

### Double Guide Block

| Stroke | L         |            | A   | B | C  | D     | E | F    | G  | H | J | Mass [kg] |            |
|--------|-----------|------------|-----|---|----|-------|---|------|----|---|---|-----------|------------|
|        | W/o Brake | With Brake |     |   |    |       |   |      |    |   |   | W/o Brake | With Brake |
| 40     | 375       | 401        | 167 | 2 | 6  | 170.5 | 3 | 10.5 | 8  | 0 | 4 | 1.7       | 1.9        |
| 65     | 400       | 426        | 192 | 3 | 8  | 195.5 | 3 | 35.5 | 8  | 0 | 4 | 1.8       | 2.0        |
| 90     | 425       | 451        | 217 | 3 | 8  | 220.5 | 4 | 10.5 | 10 | 0 | 4 | 1.9       | 2.1        |
| 140    | 475       | 501        | 267 | 4 | 10 | 270.5 | 5 | 10.5 | 12 | 1 | 6 | 2.1       | 2.2        |
| 190    | 525       | 551        | 317 | 5 | 12 | 320.5 | 6 | 10.5 | 14 | 1 | 6 | 2.3       | 2.4        |
| 240    | 575       | 601        | 367 | 6 | 14 | 370.5 | 7 | 10.5 | 16 | 2 | 8 | 2.4       | 2.6        |

(Note) L dimensions described in the table are those with no cable ejection direction (option). For cable ejection direction types (option), the dimensions are longer in 20mm.

## 5.3 Standard Specification RCP6-TA6C

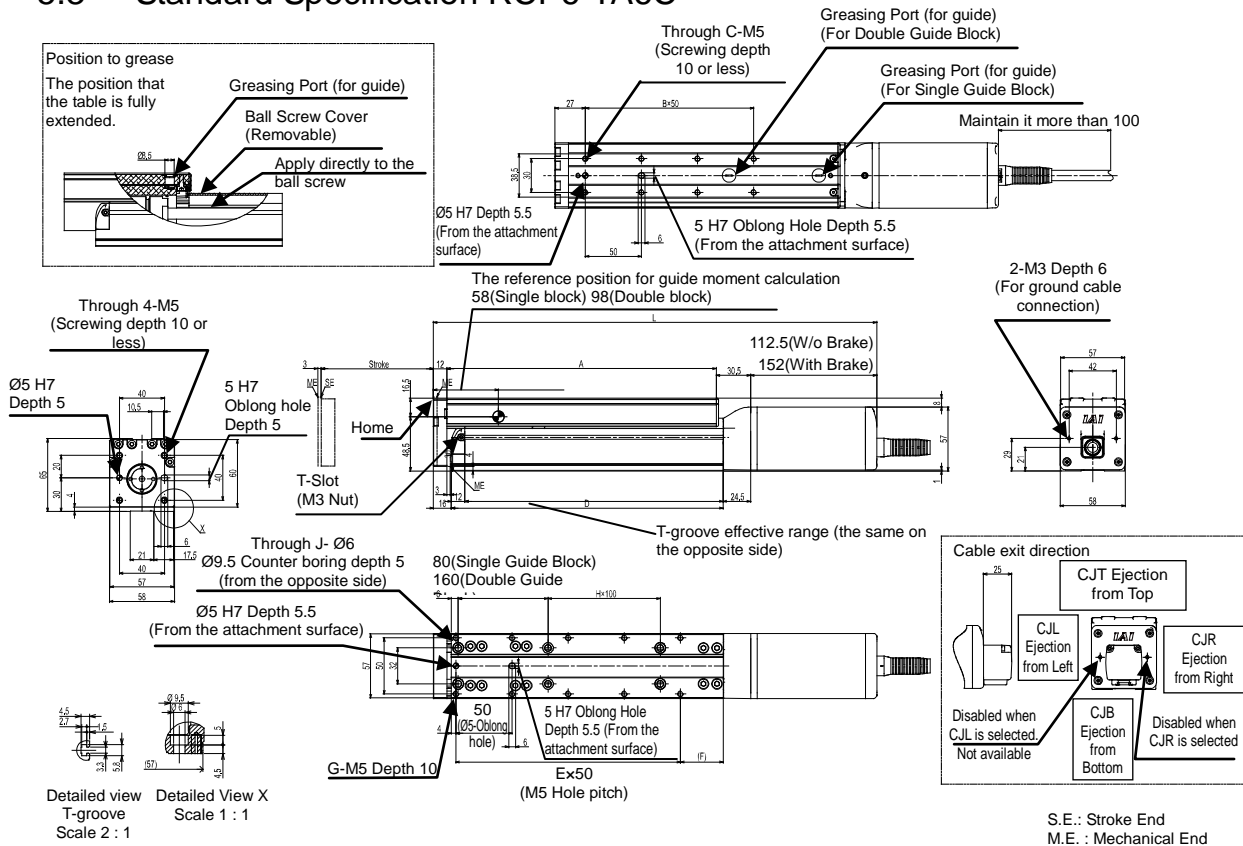

### Standard Specification (Single Guide Block)

| Stroke | L         |            | A   | B | C  | D   | E | F  | G  | H | J | Mass [kg] |            |
|--------|-----------|------------|-----|---|----|-----|---|----|----|---|---|-----------|------------|
|        | W/o Brake | With Brake |     |   |    |     |   |    |    |   |   | W/o Brake | With Brake |
| 25     | 270       | 309.5      | 115 | 1 | 4  | 117 | 2 | 13 | 6  | 0 | 4 | 2.1       | 2.3        |
| 50     | 295       | 334.5      | 140 | 1 | 4  | 142 | 2 | 38 | 6  | 0 | 4 | 2.2       | 2.5        |
| 75     | 320       | 359.5      | 165 | 2 | 6  | 167 | 3 | 13 | 8  | 0 | 4 | 2.4       | 2.6        |
| 100    | 345       | 384.5      | 190 | 2 | 6  | 192 | 3 | 38 | 8  | 0 | 4 | 2.5       | 2.8        |
| 125    | 370       | 409.5      | 215 | 3 | 8  | 217 | 4 | 13 | 10 | 1 | 6 | 2.7       | 2.9        |
| 150    | 395       | 434.5      | 240 | 3 | 8  | 242 | 4 | 38 | 10 | 1 | 6 | 2.9       | 3.1        |
| 175    | 420       | 459.5      | 265 | 4 | 10 | 267 | 5 | 13 | 12 | 1 | 6 | 3.0       | 3.3        |
| 200    | 445       | 484.5      | 290 | 4 | 10 | 292 | 5 | 38 | 12 | 1 | 6 | 3.2       | 3.4        |

### Double Guide Block

| Stroke | L         |            | A   | B | C  | D   | E | F  | G  | H | J | Mass [kg] |            |
|--------|-----------|------------|-----|---|----|-----|---|----|----|---|---|-----------|------------|
|        | W/o Brake | With Brake |     |   |    |     |   |    |    |   |   | W/o Brake | With Brake |
| 45     | 370       | 409.5      | 215 | 3 | 8  | 217 | 4 | 13 | 10 | 0 | 4 | 2.9       | 3.1        |
| 70     | 395       | 434.5      | 240 | 3 | 8  | 242 | 4 | 38 | 10 | 0 | 4 | 3.0       | 3.3        |
| 95     | 420       | 459.5      | 265 | 4 | 10 | 267 | 5 | 13 | 12 | 0 | 4 | 3.2       | 3.4        |
| 120    | 445       | 484.5      | 290 | 4 | 10 | 292 | 5 | 38 | 12 | 0 | 4 | 3.3       | 3.6        |
| 170    | 495       | 534.5      | 340 | 5 | 12 | 342 | 6 | 38 | 14 | 1 | 6 | 3.7       | 3.9        |
| 220    | 545       | 584.5      | 390 | 6 | 14 | 392 | 7 | 38 | 16 | 1 | 6 | 4.0       | 4.2        |
| 270    | 595       | 634.5      | 440 | 7 | 16 | 442 | 8 | 38 | 18 | 2 | 8 | 4.3       | 4.5        |
| 320    | 645       | 684.5      | 490 | 8 | 18 | 492 | 9 | 38 | 20 | 2 | 8 | 4.6       | 4.9        |

(Note) L dimensions described in the table are those with no cable ejection direction (option). For cable ejection direction types (option), the dimensions are longer in 25mm.

## 5.4 Built-in Controller Specification RCP6S-TA6C

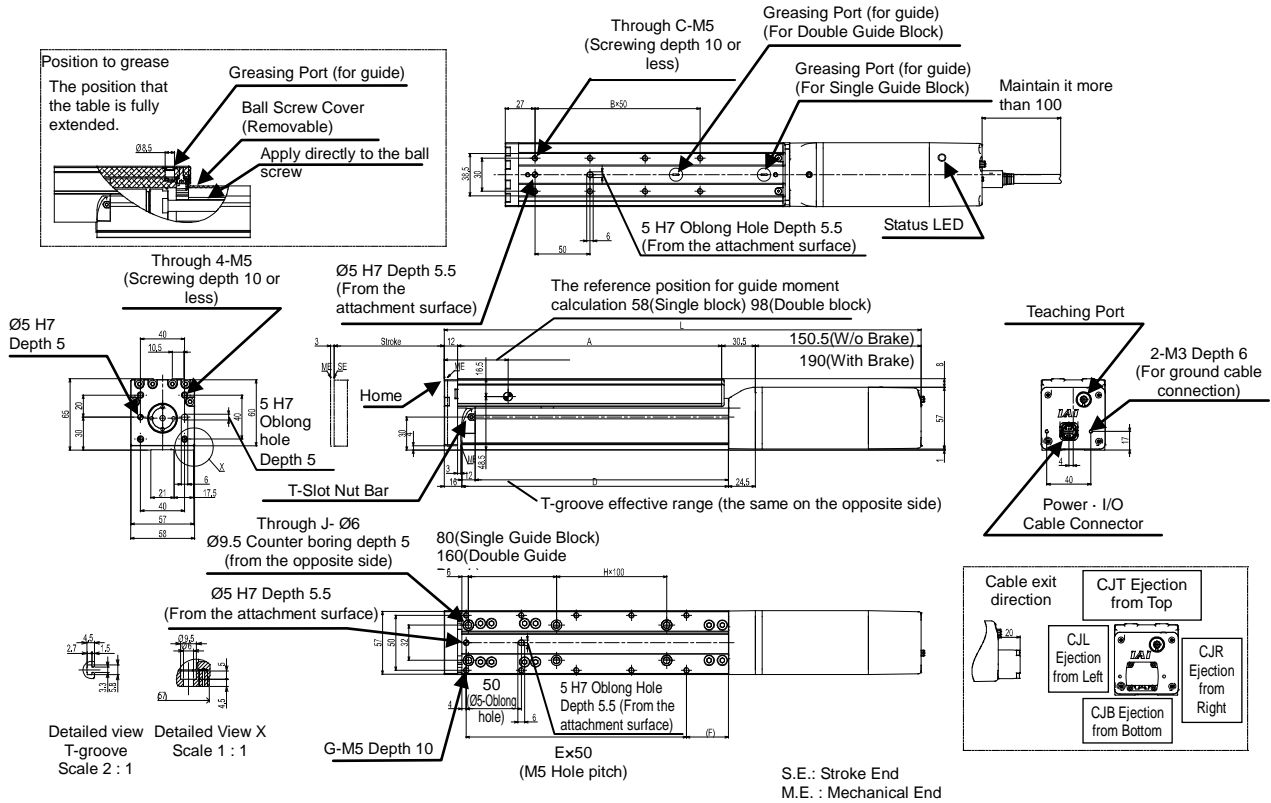

### Standard Specification (Single Guide Block)

| Stroke | L         |            | A   | B | C  | D   | E | F  | G  | H | J | Mass [kg] |            |
|--------|-----------|------------|-----|---|----|-----|---|----|----|---|---|-----------|------------|
|        | W/o Brake | With Brake |     |   |    |     |   |    |    |   |   | W/o Brake | With Brake |
| 25     | 308       | 347.5      | 115 | 1 | 4  | 117 | 2 | 13 | 6  | 0 | 4 | 2.2       | 2.4        |
| 50     | 333       | 372.5      | 140 | 1 | 4  | 142 | 2 | 38 | 6  | 0 | 4 | 2.4       | 2.6        |
| 75     | 358       | 397.5      | 165 | 2 | 6  | 167 | 3 | 13 | 8  | 0 | 4 | 2.5       | 2.8        |
| 100    | 383       | 422.5      | 190 | 2 | 6  | 192 | 3 | 38 | 8  | 0 | 4 | 2.7       | 2.9        |
| 125    | 408       | 447.5      | 215 | 3 | 8  | 217 | 4 | 13 | 10 | 1 | 6 | 2.8       | 3.1        |
| 150    | 433       | 472.5      | 240 | 3 | 8  | 242 | 4 | 38 | 10 | 1 | 6 | 3.0       | 3.2        |
| 175    | 458       | 497.5      | 265 | 4 | 10 | 267 | 5 | 13 | 12 | 1 | 6 | 3.2       | 3.4        |
| 200    | 483       | 522.5      | 290 | 4 | 10 | 292 | 5 | 38 | 12 | 1 | 6 | 3.3       | 3.6        |

### Double Guide Block

| Stroke | L         |            | A   | B | C  | D   | E | F  | G  | H | J | Mass [kg] |            |
|--------|-----------|------------|-----|---|----|-----|---|----|----|---|---|-----------|------------|
|        | W/o Brake | With Brake |     |   |    |     |   |    |    |   |   | W/o Brake | With Brake |
| 45     | 408       | 447.5      | 215 | 3 | 8  | 217 | 4 | 13 | 10 | 0 | 4 | 3.0       | 3.2        |
| 70     | 433       | 472.5      | 240 | 3 | 8  | 242 | 4 | 38 | 10 | 0 | 4 | 3.2       | 3.4        |
| 95     | 458       | 497.5      | 265 | 4 | 10 | 267 | 5 | 13 | 12 | 0 | 4 | 3.3       | 3.6        |
| 120    | 483       | 522.5      | 290 | 4 | 10 | 292 | 5 | 38 | 12 | 0 | 4 | 3.5       | 3.7        |
| 170    | 533       | 572.5      | 340 | 5 | 12 | 342 | 6 | 38 | 14 | 1 | 6 | 3.8       | 4.0        |
| 220    | 583       | 622.5      | 390 | 6 | 14 | 392 | 7 | 38 | 16 | 1 | 6 | 4.1       | 4.4        |
| 270    | 633       | 672.5      | 440 | 7 | 16 | 442 | 8 | 38 | 18 | 2 | 8 | 4.4       | 4.7        |
| 320    | 683       | 722.5      | 490 | 8 | 18 | 492 | 9 | 38 | 20 | 2 | 8 | 4.8       | 5.0        |

(Note) L dimensions described in the table are those with no cable ejection direction (option). For cable ejection direction types (option), the dimensions are longer in 20mm.

## 5.5 Standard Specification RCP6-TA7C

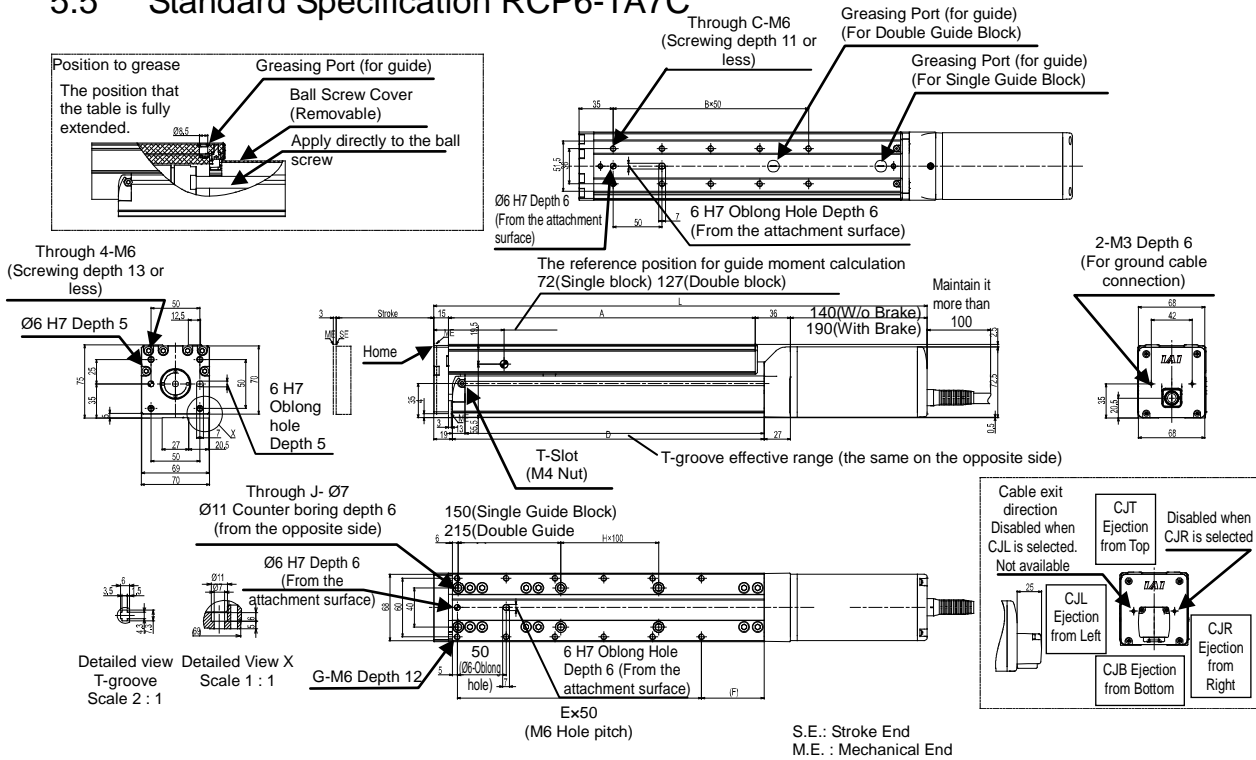

Standard Specification (Single Guide Block)

| Stroke | L         |            | A   | B | C  | D   | E | F  | G  | H | J | Mass [kg] |            |
|--------|-----------|------------|-----|---|----|-----|---|----|----|---|---|-----------|------------|
|        | W/o Brake | With Brake |     |   |    |     |   |    |    |   |   | W/o Brake | With Brake |
| 25     | 330       | 380        | 139 | 1 | 4  | 144 | 2 | 39 | 6  | 0 | 4 | 3.9       | 4.3        |
| 50     | 355       | 405        | 164 | 1 | 4  | 169 | 2 | 64 | 6  | 0 | 4 | 4.1       | 4.5        |
| 75     | 380       | 430        | 189 | 2 | 6  | 194 | 3 | 39 | 8  | 0 | 4 | 4.3       | 4.7        |
| 100    | 405       | 455        | 214 | 2 | 6  | 219 | 3 | 64 | 8  | 0 | 4 | 4.5       | 5.0        |
| 125    | 430       | 480        | 239 | 3 | 8  | 244 | 4 | 39 | 10 | 1 | 6 | 4.7       | 5.2        |
| 150    | 455       | 505        | 264 | 3 | 8  | 269 | 4 | 64 | 10 | 1 | 6 | 5.0       | 5.4        |
| 175    | 480       | 530        | 289 | 4 | 10 | 294 | 5 | 39 | 12 | 1 | 6 | 5.2       | 5.6        |
| 200    | 505       | 555        | 314 | 4 | 10 | 319 | 5 | 64 | 12 | 1 | 6 | 5.4       | 5.8        |
| 250    | 555       | 605        | 364 | 5 | 12 | 369 | 6 | 64 | 14 | 2 | 8 | 5.8       | 6.3        |
| 300    | 605       | 655        | 414 | 6 | 14 | 419 | 7 | 64 | 16 | 2 | 8 | 6.3       | 6.7        |

Double Guide Block

| Stroke | L         |            | A   | B  | C  | D   | E  | F  | G  | H | J  | Mass [kg] |            |
|--------|-----------|------------|-----|----|----|-----|----|----|----|---|----|-----------|------------|
|        | W/o Brake | With Brake |     |    |    |     |    |    |    |   |    | W/o Brake | With Brake |
| 40     | 455       | 505        | 264 | 3  | 8  | 269 | 4  | 64 | 10 | 0 | 4  | 5.3       | 5.8        |
| 65     | 480       | 530        | 289 | 4  | 10 | 294 | 5  | 39 | 12 | 0 | 4  | 5.6       | 6.0        |
| 90     | 505       | 555        | 314 | 4  | 10 | 319 | 5  | 64 | 12 | 0 | 4  | 5.8       | 6.2        |
| 140    | 555       | 605        | 364 | 5  | 12 | 369 | 6  | 64 | 14 | 1 | 6  | 6.2       | 6.6        |
| 190    | 605       | 655        | 414 | 6  | 14 | 419 | 7  | 64 | 16 | 1 | 6  | 6.6       | 7.1        |
| 240    | 655       | 705        | 464 | 7  | 16 | 469 | 8  | 64 | 18 | 2 | 8  | 7.1       | 7.5        |
| 290    | 705       | 755        | 514 | 8  | 18 | 519 | 9  | 64 | 20 | 2 | 8  | 7.5       | 8.0        |
| 340    | 755       | 805        | 564 | 9  | 20 | 569 | 10 | 64 | 22 | 3 | 10 | 8.0       | 8.4        |
| 390    | 805       | 855        | 614 | 10 | 22 | 619 | 11 | 64 | 24 | 3 | 10 | 8.4       | 8.8        |

(Note) L dimensions described in the table are those with no cable ejection direction (option). For cable ejection direction types (option), the dimensions are longer in 25mm.

## 5.6 Built-in Controller Specification RCP6S-TA7C

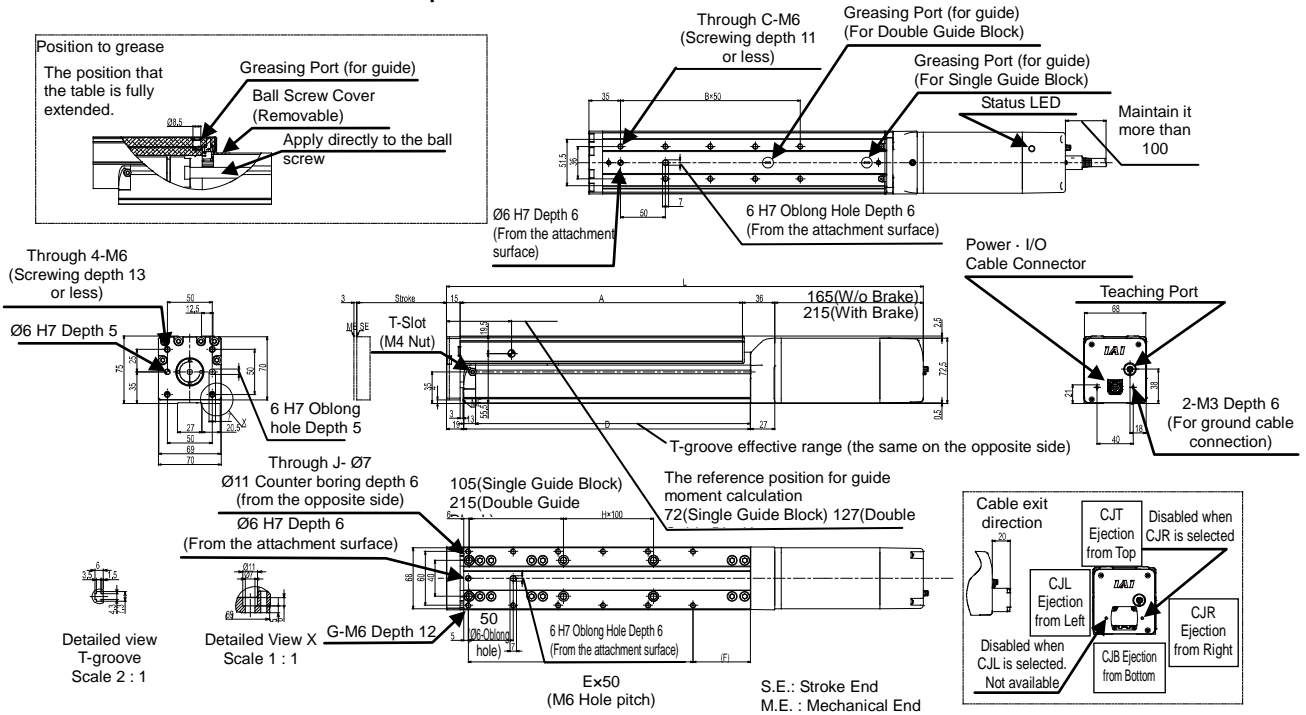

### Standard Specification (Single Guide Block)

| Stroke | L         |            | A   | B | C  | D   | E | F  | G  | H | J | Mass [kg] |            |
|--------|-----------|------------|-----|---|----|-----|---|----|----|---|---|-----------|------------|
|        | W/o Brake | With Brake |     |   |    |     |   |    |    |   |   | W/o Brake | With Brake |
| 25     | 355       | 405        | 139 | 1 | 4  | 144 | 2 | 39 | 6  | 0 | 4 | 4.0       | 4.5        |
| 50     | 380       | 430        | 164 | 1 | 4  | 169 | 2 | 64 | 6  | 0 | 4 | 4.3       | 4.7        |
| 75     | 405       | 455        | 189 | 2 | 6  | 194 | 3 | 39 | 8  | 0 | 4 | 4.5       | 4.9        |
| 100    | 430       | 480        | 214 | 2 | 6  | 219 | 3 | 64 | 8  | 0 | 4 | 4.7       | 5.1        |
| 125    | 455       | 505        | 239 | 3 | 8  | 244 | 4 | 39 | 10 | 1 | 6 | 4.9       | 5.3        |
| 150    | 480       | 530        | 264 | 3 | 8  | 269 | 4 | 64 | 10 | 1 | 6 | 5.1       | 5.6        |
| 175    | 505       | 555        | 289 | 4 | 10 | 294 | 5 | 39 | 12 | 1 | 6 | 5.3       | 5.8        |
| 200    | 530       | 580        | 314 | 4 | 10 | 319 | 5 | 64 | 12 | 1 | 6 | 5.6       | 6.0        |
| 250    | 580       | 630        | 364 | 5 | 12 | 369 | 6 | 64 | 14 | 2 | 8 | 6.0       | 6.4        |
| 300    | 630       | 680        | 414 | 6 | 14 | 419 | 7 | 64 | 16 | 2 | 8 | 6.4       | 6.9        |

### Double Guide Block

| Stroke | L         |            | A   | B  | C  | D   | E  | F  | G  | H | J  | Mass [kg] |            |
|--------|-----------|------------|-----|----|----|-----|----|----|----|---|----|-----------|------------|
|        | W/o Brake | With Brake |     |    |    |     |    |    |    |   |    | W/o Brake | With Brake |
| 40     | 480       | 530        | 264 | 3  | 8  | 269 | 4  | 64 | 10 | 0 | 4  | 5.5       | 5.9        |
| 65     | 505       | 555        | 289 | 4  | 10 | 294 | 5  | 39 | 12 | 0 | 4  | 5.7       | 6.2        |
| 90     | 530       | 580        | 314 | 4  | 10 | 319 | 5  | 64 | 12 | 0 | 4  | 5.9       | 6.4        |
| 140    | 580       | 630        | 364 | 5  | 12 | 369 | 6  | 64 | 14 | 1 | 6  | 6.4       | 6.8        |
| 190    | 630       | 680        | 414 | 6  | 14 | 419 | 7  | 64 | 16 | 1 | 6  | 6.8       | 7.3        |
| 240    | 680       | 730        | 464 | 7  | 16 | 469 | 8  | 64 | 18 | 2 | 8  | 7.3       | 7.7        |
| 290    | 730       | 780        | 514 | 8  | 18 | 519 | 9  | 64 | 20 | 2 | 8  | 7.7       | 8.1        |
| 340    | 780       | 830        | 564 | 9  | 20 | 569 | 10 | 64 | 22 | 3 | 10 | 8.1       | 8.6        |
| 390    | 830       | 880        | 614 | 10 | 22 | 619 | 11 | 64 | 24 | 3 | 10 | 8.6       | 9.0        |

(Note) L dimensions described in the table are those with no cable ejection direction (option). For cable ejection direction types (option), the dimensions are longer in 20mm.

### 5.7 Standard Specification RCP6-TA4R Left Side-Mounted (Model: ML) (Note) For Right Side-Mounted (model: MR), side-mounted motor will be on the right side in the drawing beneath.

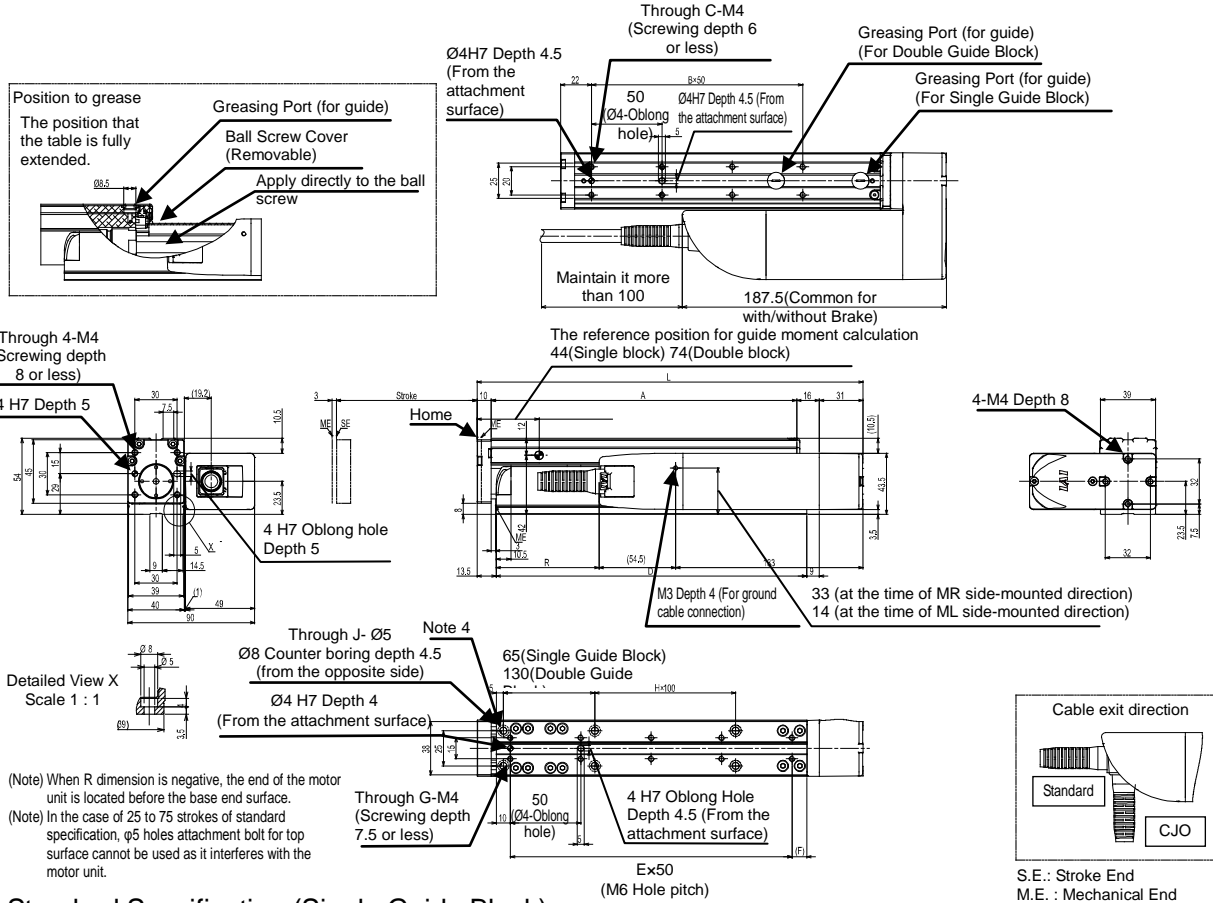

#### Standard Specification (Single Guide Block)

| Stroke | L   | A   | B | C | D     | E | F    | G  | H | J | R   | Mass [kg] |            |
|--------|-----|-----|---|---|-------|---|------|----|---|---|-----|-----------|------------|
|        |     |     |   |   |       |   |      |    |   |   |     | W/o Brake | With Brake |
| 25     | 149 | 92  | 1 | 4 | 95.5  | 1 | 35.5 | 4  | 0 | 4 | -52 | 1.3       | 1.4        |
| 50     | 174 | 117 | 1 | 4 | 120.5 | 2 | 10.5 | 6  | 0 | 4 | -27 | 1.4       | 1.5        |
| 75     | 199 | 142 | 2 | 6 | 145.5 | 2 | 35.5 | 6  | 0 | 4 | -2  | 1.5       | 1.6        |
| 100    | 224 | 167 | 2 | 6 | 170.5 | 3 | 10.5 | 8  | 0 | 4 | 23  | 1.6       | 1.7        |
| 125    | 249 | 192 | 3 | 8 | 195.5 | 3 | 35.5 | 8  | 1 | 6 | 48  | 1.7       | 1.8        |
| 150    | 274 | 217 | 3 | 8 | 220.5 | 4 | 10.5 | 10 | 1 | 6 | 73  | 1.8       | 1.8        |

#### Double Guide Block

| Stroke | L   | A   | B | C  | D     | E | F    | G  | H | J | R   | Mass [kg] |            |
|--------|-----|-----|---|----|-------|---|------|----|---|---|-----|-----------|------------|
|        |     |     |   |    |       |   |      |    |   |   |     | W/o Brake | With Brake |
| 40     | 224 | 167 | 2 | 6  | 170.5 | 3 | 10.5 | 8  | 0 | 4 | 23  | 1.7       | 1.8        |
| 65     | 249 | 192 | 3 | 8  | 195.5 | 3 | 35.5 | 8  | 0 | 4 | 48  | 1.8       | 1.9        |
| 90     | 274 | 217 | 3 | 8  | 220.5 | 4 | 10.5 | 10 | 0 | 4 | 73  | 1.9       | 1.9        |
| 140    | 324 | 267 | 4 | 10 | 270.5 | 5 | 10.5 | 12 | 1 | 6 | 123 | 2.1       | 2.1        |
| 190    | 374 | 317 | 5 | 12 | 320.5 | 6 | 10.5 | 14 | 1 | 6 | 173 | 2.2       | 2.3        |
| 240    | 424 | 367 | 6 | 14 | 370.5 | 7 | 10.5 | 16 | 2 | 8 | 223 | 2.4       | 2.5        |

## 5.8 Built-in Controller Specification RCP6S-TA4R Left Side-Mounted (Model: ML)

(Note) For Right Side-Mounted (model: MR), side-mounted motor will be on the right side in the drawing beneath.

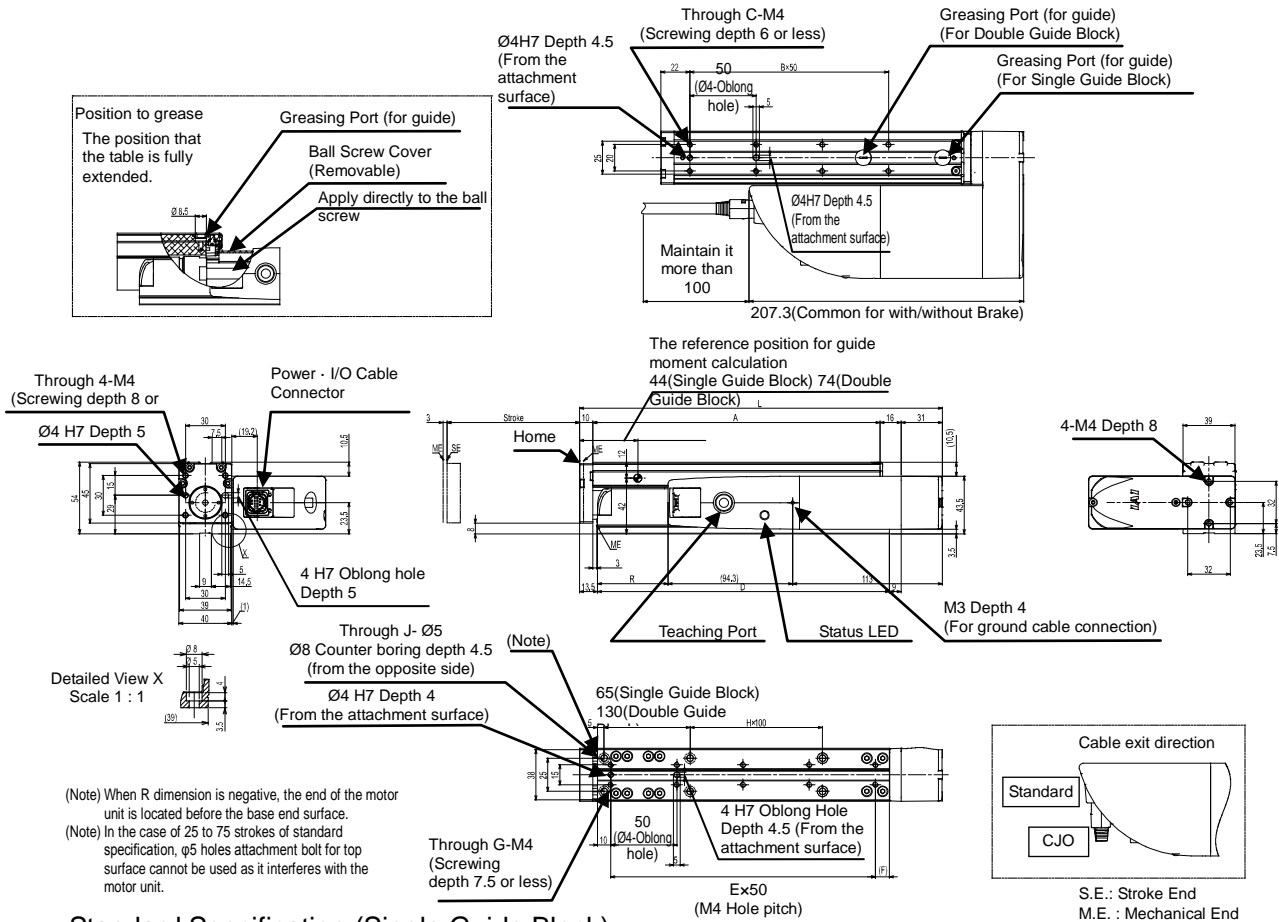

### Standard Specification (Single Guide Block)

| Stroke | L   | A   | B | C | D     | E | F    | G  | H | J | R     | Mass [kg] |            |
|--------|-----|-----|---|---|-------|---|------|----|---|---|-------|-----------|------------|
|        |     |     |   |   |       |   |      |    |   |   |       | W/o Brake | With Brake |
| 25     | 149 | 92  | 1 | 4 | 95.5  | 1 | 35.5 | 4  | 0 | 4 | -71.8 | 1.5       | 1.5        |
| 50     | 174 | 117 | 1 | 4 | 120.5 | 2 | 10.5 | 6  | 0 | 4 | -46.8 | 1.6       | 1.6        |
| 75     | 199 | 142 | 2 | 6 | 145.5 | 2 | 35.5 | 6  | 0 | 4 | -21.8 | 1.6       | 1.7        |
| 100    | 224 | 167 | 2 | 6 | 170.5 | 3 | 10.5 | 8  | 0 | 4 | 3.2   | 1.7       | 1.8        |
| 125    | 249 | 192 | 3 | 8 | 195.5 | 3 | 35.5 | 8  | 1 | 6 | 28.2  | 1.8       | 1.9        |
| 150    | 274 | 217 | 3 | 8 | 220.5 | 4 | 10.5 | 10 | 1 | 6 | 53.2  | 1.9       | 2.0        |

### Double Guide Block

| Stroke | L   | A   | B | C  | D     | E | F    | G  | H | J | R     | Mass [kg] |            |
|--------|-----|-----|---|----|-------|---|------|----|---|---|-------|-----------|------------|
|        |     |     |   |    |       |   |      |    |   |   |       | W/o Brake | With Brake |
| 40     | 224 | 167 | 2 | 6  | 170.5 | 3 | 10.5 | 8  | 0 | 4 | 3.2   | 1.8       | 1.9        |
| 65     | 249 | 192 | 3 | 8  | 195.5 | 3 | 35.5 | 8  | 0 | 4 | 28.2  | 1.9       | 2.0        |
| 90     | 274 | 217 | 3 | 8  | 220.5 | 4 | 10.5 | 10 | 0 | 4 | 53.2  | 2.0       | 2.1        |
| 140    | 324 | 267 | 4 | 10 | 270.5 | 5 | 10.5 | 12 | 1 | 6 | 103.2 | 2.2       | 2.2        |
| 190    | 374 | 317 | 5 | 12 | 320.5 | 6 | 10.5 | 14 | 1 | 6 | 153.2 | 2.4       | 2.4        |
| 240    | 424 | 367 | 6 | 14 | 370.5 | 7 | 10.5 | 16 | 2 | 8 | 203.2 | 2.5       | 2.6        |

### 5.9 Standard Specification RCP6-TA6R Left Side-Mounted (Model: ML) (Note) For Right Side-Mounted (model: MR), side-mounted motor will be on the right side in the drawing beneath.

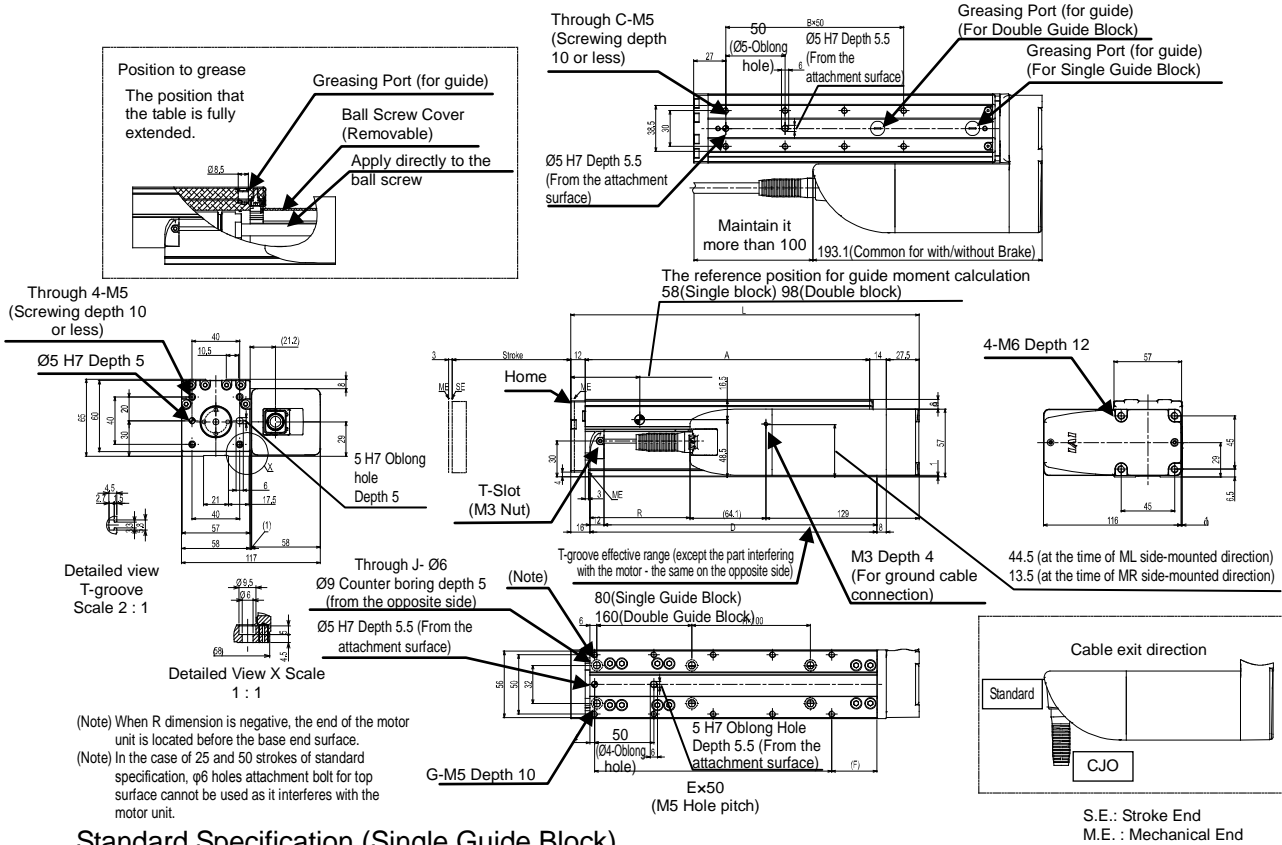

#### Standard Specification (Single Guide Block)

| Stroke | L     | A   | B | C  | D   | E | F  | G  | H | J | R     | Mass [kg] |            |
|--------|-------|-----|---|----|-----|---|----|----|---|---|-------|-----------|------------|
|        |       |     |   |    |     |   |    |    |   |   |       | W/o Brake | With Brake |
| 25     | 168.5 | 115 | 1 | 4  | 117 | 2 | 13 | 6  | 0 | 4 | -40.6 | 2.3       | 2.4        |
| 50     | 193.5 | 140 | 1 | 4  | 142 | 2 | 38 | 6  | 0 | 4 | -15.6 | 2.5       | 2.6        |
| 75     | 218.5 | 165 | 2 | 6  | 167 | 3 | 13 | 8  | 0 | 4 | 9.4   | 2.7       | 2.7        |
| 100    | 243.5 | 190 | 2 | 6  | 192 | 3 | 38 | 8  | 0 | 4 | 34.4  | 2.8       | 2.9        |
| 125    | 268.5 | 215 | 3 | 8  | 217 | 4 | 13 | 10 | 1 | 6 | 59.4  | 3.0       | 3.0        |
| 150    | 293.5 | 240 | 3 | 8  | 242 | 4 | 38 | 10 | 1 | 6 | 84.4  | 3.1       | 3.2        |
| 175    | 318.5 | 265 | 4 | 10 | 267 | 5 | 13 | 12 | 1 | 6 | 109.4 | 3.3       | 3.4        |
| 200    | 343.5 | 290 | 4 | 10 | 292 | 5 | 38 | 12 | 1 | 6 | 134.4 | 3.5       | 3.5        |

#### Double Guide Block

| Stroke | L     | A   | B | C  | D   | E | F  | G  | H | J | R     | Mass [kg] |            |
|--------|-------|-----|---|----|-----|---|----|----|---|---|-------|-----------|------------|
|        |       |     |   |    |     |   |    |    |   |   |       | W/o Brake | With Brake |
| 45     | 268.5 | 215 | 3 | 8  | 217 | 4 | 13 | 10 | 0 | 4 | 59.4  | 3.2       | 3.3        |
| 70     | 293.5 | 240 | 3 | 8  | 242 | 4 | 38 | 10 | 0 | 4 | 84.4  | 3.4       | 3.4        |
| 95     | 318.5 | 265 | 4 | 10 | 267 | 5 | 13 | 12 | 0 | 4 | 109.4 | 3.5       | 3.6        |
| 120    | 343.5 | 290 | 4 | 10 | 292 | 5 | 38 | 12 | 0 | 4 | 134.4 | 3.7       | 3.8        |
| 170    | 393.5 | 340 | 5 | 12 | 342 | 6 | 38 | 14 | 1 | 6 | 184.4 | 4.0       | 4.1        |
| 220    | 443.5 | 390 | 6 | 14 | 392 | 7 | 38 | 16 | 1 | 6 | 234.4 | 4.3       | 4.4        |
| 270    | 493.5 | 440 | 7 | 16 | 442 | 8 | 38 | 18 | 2 | 8 | 284.4 | 4.7       | 4.7        |
| 320    | 543.5 | 490 | 8 | 18 | 492 | 9 | 38 | 20 | 2 | 8 | 334.4 | 5.0       | 5.0        |

## 5.10 Built-in Controller Specification RCP6S-TA6R Left Side-Mounted (Model: ML)

(Note) For Right Side-Mounted (model: MR), side-mounted motor will be on the right side in the drawing beneath.

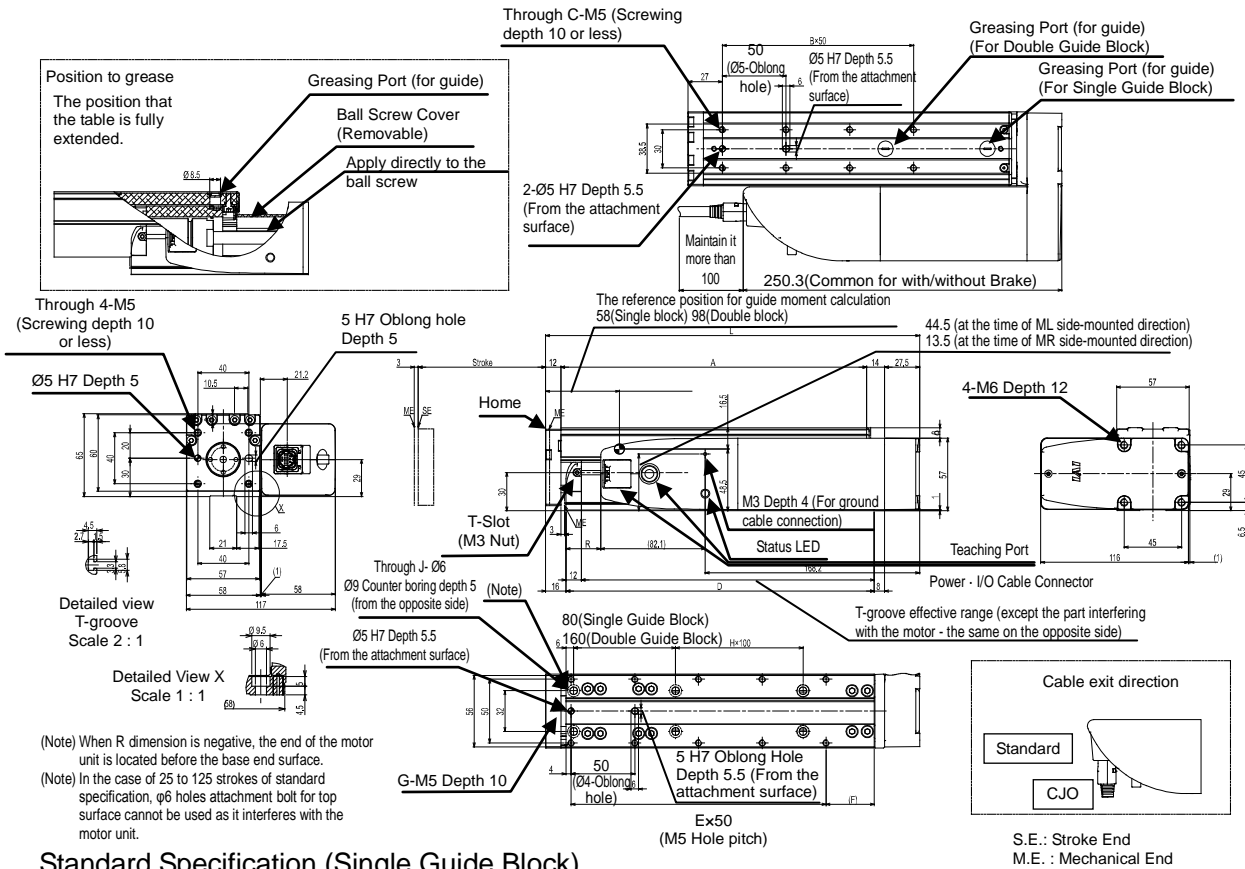

### Standard Specification (Single Guide Block)

| Stroke | L     | A   | B | C  | D   | E | F  | G  | H | J | R     | Mass [kg] |            |
|--------|-------|-----|---|----|-----|---|----|----|---|---|-------|-----------|------------|
|        |       |     |   |    |     |   |    |    |   |   |       | W/o Brake | With Brake |
| 25     | 168.5 | 115 | 1 | 4  | 117 | 2 | 13 | 6  | 0 | 4 | -97.8 | 2.5       | 2.5        |
| 50     | 193.5 | 140 | 1 | 4  | 142 | 2 | 38 | 6  | 0 | 4 | -72.8 | 2.6       | 2.7        |
| 75     | 218.5 | 165 | 2 | 6  | 167 | 3 | 13 | 8  | 0 | 4 | -47.8 | 2.8       | 2.9        |
| 100    | 243.5 | 190 | 2 | 6  | 192 | 3 | 38 | 8  | 0 | 4 | -22.8 | 3.0       | 3.0        |
| 125    | 268.5 | 215 | 3 | 8  | 217 | 4 | 13 | 10 | 1 | 6 | 2.2   | 3.1       | 3.2        |
| 150    | 293.5 | 240 | 3 | 8  | 242 | 4 | 38 | 10 | 1 | 6 | 27.2  | 3.3       | 3.3        |
| 175    | 318.5 | 265 | 4 | 10 | 267 | 5 | 13 | 12 | 1 | 6 | 52.2  | 3.4       | 3.5        |
| 200    | 343.5 | 290 | 4 | 10 | 292 | 5 | 38 | 12 | 1 | 6 | 77.2  | 3.6       | 3.7        |

### Double Guide Block

| Stroke | L     | A   | B | C  | D   | E | F  | G  | H | J | R     | Mass [kg] |            |
|--------|-------|-----|---|----|-----|---|----|----|---|---|-------|-----------|------------|
|        |       |     |   |    |     |   |    |    |   |   |       | W/o Brake | With Brake |
| 45     | 268.5 | 215 | 3 | 8  | 217 | 4 | 13 | 10 | 0 | 4 | 2.2   | 3.3       | 3.4        |
| 70     | 293.5 | 240 | 3 | 8  | 242 | 4 | 38 | 10 | 0 | 4 | 27.2  | 3.5       | 3.6        |
| 95     | 318.5 | 265 | 4 | 10 | 267 | 5 | 13 | 12 | 0 | 4 | 52.2  | 3.7       | 3.7        |
| 120    | 343.5 | 290 | 4 | 10 | 292 | 5 | 38 | 12 | 0 | 4 | 77.2  | 3.8       | 3.9        |
| 170    | 393.5 | 340 | 5 | 12 | 342 | 6 | 38 | 14 | 1 | 6 | 127.2 | 4.1       | 4.2        |
| 220    | 443.5 | 390 | 6 | 14 | 392 | 7 | 38 | 16 | 1 | 6 | 177.2 | 4.5       | 4.5        |
| 270    | 493.5 | 440 | 7 | 16 | 442 | 8 | 38 | 18 | 2 | 8 | 227.2 | 4.8       | 4.9        |
| 320    | 543.5 | 490 | 8 | 18 | 492 | 9 | 38 | 20 | 2 | 8 | 277.2 | 5.1       | 5.2        |

### 5.11 Standard Specification RCP6-TA7R Left Side-Mounted (Model: ML) (Note) For Right Side-Mounted (model: MR), side-mounted motor will be on the right side in the drawing beneath.

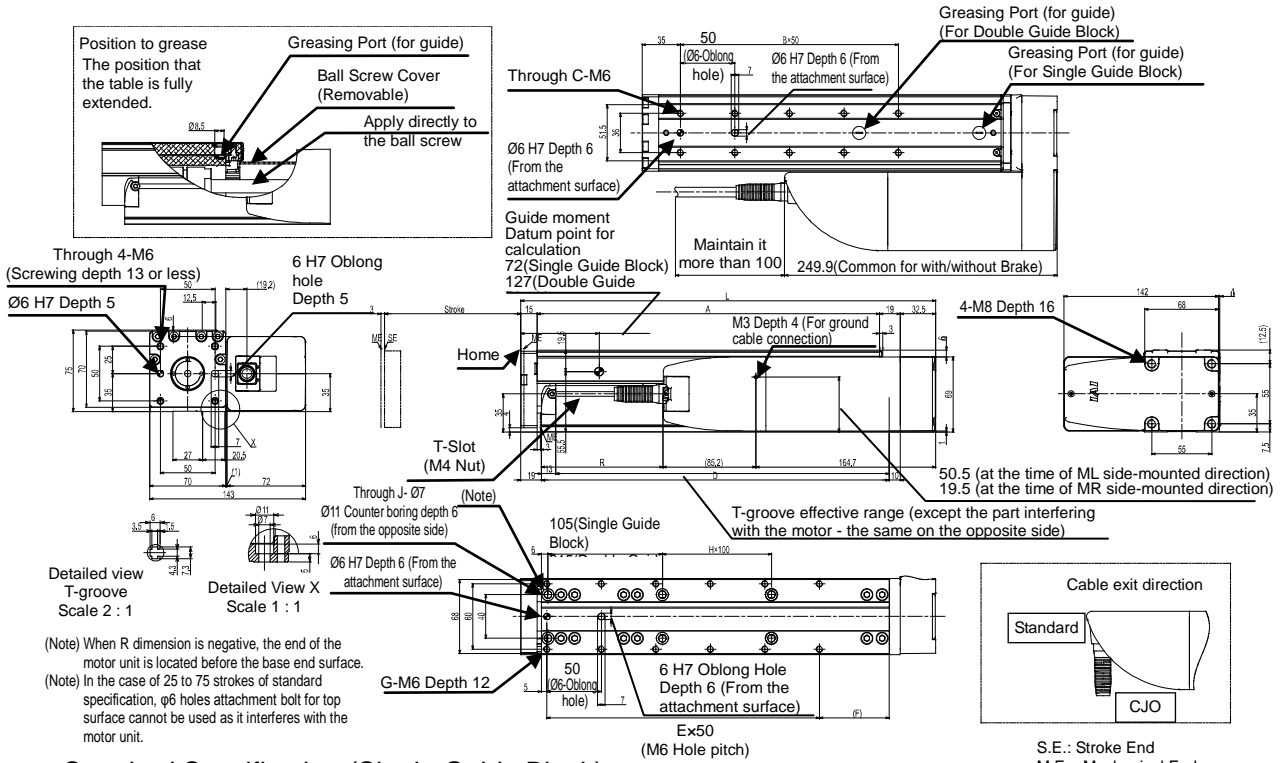

#### Standard Specification (Single Guide Block)

| Stroke | L     | A   | B | C  | D   | E | F  | G  | H | J | R     | Mass [kg] |            |
|--------|-------|-----|---|----|-----|---|----|----|---|---|-------|-----------|------------|
|        |       |     |   |    |     |   |    |    |   |   |       | W/o Brake | With Brake |
| 25     | 205.5 | 139 | 1 | 4  | 144 | 2 | 39 | 6  | 0 | 4 | -63.4 | 4.4       | 4.5        |
| 50     | 230.5 | 164 | 1 | 4  | 169 | 2 | 64 | 6  | 0 | 4 | -38.4 | 4.6       | 4.8        |
| 75     | 255.5 | 189 | 2 | 6  | 194 | 3 | 39 | 8  | 0 | 4 | -13.4 | 4.9       | 5.0        |
| 100    | 280.5 | 214 | 2 | 6  | 219 | 3 | 64 | 8  | 0 | 4 | 11.6  | 5.1       | 5.2        |
| 125    | 305.5 | 239 | 3 | 8  | 244 | 4 | 39 | 10 | 1 | 6 | 36.6  | 5.3       | 5.4        |
| 150    | 330.5 | 264 | 3 | 8  | 269 | 4 | 64 | 10 | 1 | 6 | 61.6  | 5.5       | 5.6        |
| 175    | 355.5 | 289 | 4 | 10 | 294 | 5 | 39 | 12 | 1 | 6 | 86.6  | 5.7       | 5.8        |
| 200    | 380.5 | 314 | 4 | 10 | 319 | 5 | 64 | 12 | 1 | 6 | 111.6 | 5.9       | 6.0        |
| 250    | 430.5 | 364 | 5 | 12 | 369 | 6 | 64 | 14 | 2 | 8 | 161.6 | 6.4       | 6.5        |
| 300    | 480.5 | 414 | 6 | 14 | 419 | 7 | 64 | 16 | 2 | 8 | 211.6 | 6.8       | 6.9        |

#### Double Guide Block

| Stroke | L     | A   | B  | C  | D   | E  | F  | G  | H | J  | R     | Mass [kg] |            |
|--------|-------|-----|----|----|-----|----|----|----|---|----|-------|-----------|------------|
|        |       |     |    |    |     |    |    |    |   |    |       | W/o Brake | With Brake |
| 40     | 330.5 | 264 | 3  | 8  | 269 | 4  | 64 | 10 | 0 | 4  | 61.6  | 6.0       | 6.1        |
| 65     | 355.5 | 289 | 4  | 10 | 294 | 5  | 39 | 12 | 0 | 4  | 86.6  | 6.2       | 6.3        |
| 90     | 380.5 | 314 | 4  | 10 | 319 | 5  | 64 | 12 | 0 | 4  | 111.6 | 6.4       | 6.5        |
| 140    | 430.5 | 364 | 5  | 12 | 369 | 6  | 64 | 14 | 1 | 6  | 161.6 | 6.9       | 7.0        |
| 190    | 480.5 | 414 | 6  | 14 | 419 | 7  | 64 | 16 | 1 | 6  | 211.6 | 7.3       | 7.4        |
| 240    | 530.5 | 464 | 7  | 16 | 469 | 8  | 64 | 18 | 2 | 8  | 261.6 | 7.7       | 7.8        |
| 290    | 580.5 | 514 | 8  | 18 | 519 | 9  | 64 | 20 | 2 | 8  | 311.6 | 8.2       | 8.3        |
| 340    | 630.5 | 564 | 9  | 20 | 569 | 10 | 64 | 22 | 3 | 10 | 361.6 | 8.6       | 8.7        |
| 390    | 680.5 | 614 | 10 | 22 | 619 | 11 | 64 | 24 | 3 | 10 | 411.6 | 9.1       | 9.2        |

## 5.12 Built-in Controller Specification RCP6S-TA7R Left Side-Mounted (Model: ML)

(Note) For Right Side-Mounted (model: MR), side-mounted motor will be on the right side in the drawing beneath.

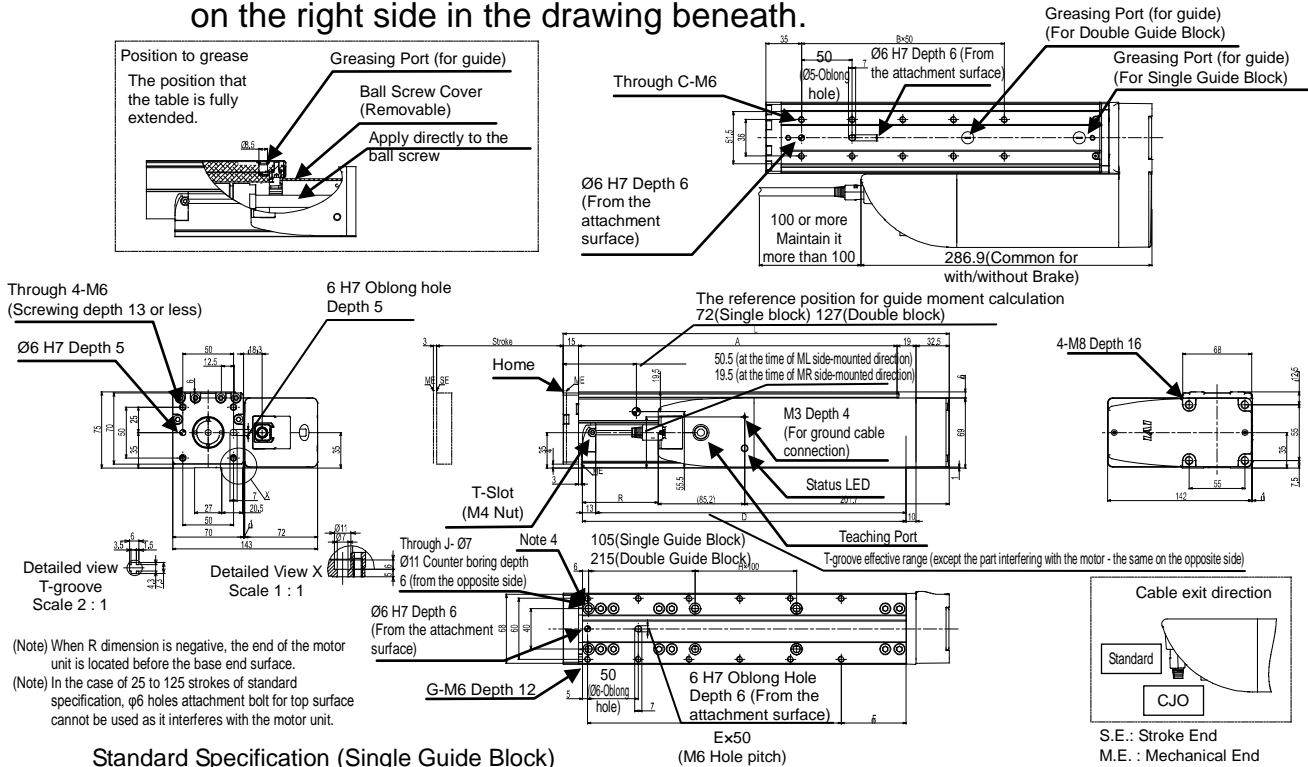

Standard Specification (Single Guide Block)

| Stroke | L     | A   | B | C  | D   | E | F  | G  | H | J | R      | Mass [kg] |            |
|--------|-------|-----|---|----|-----|---|----|----|---|---|--------|-----------|------------|
|        |       |     |   |    |     |   |    |    |   |   |        | W/o Brake | With Brake |
| 25     | 205.5 | 139 | 1 | 4  | 144 | 2 | 39 | 6  | 0 | 4 | -100.4 | 4.5       | 4.6        |
| 50     | 230.5 | 164 | 1 | 4  | 169 | 2 | 64 | 6  | 0 | 4 | -75.4  | 4.8       | 4.9        |
| 75     | 255.5 | 189 | 2 | 6  | 194 | 3 | 39 | 8  | 0 | 4 | -50.4  | 5.0       | 5.1        |
| 100    | 280.5 | 214 | 2 | 6  | 219 | 3 | 64 | 8  | 0 | 4 | -25.4  | 5.2       | 5.3        |
| 125    | 305.5 | 239 | 3 | 8  | 244 | 4 | 39 | 10 | 1 | 6 | -0.4   | 5.4       | 5.5        |
| 150    | 330.5 | 264 | 3 | 8  | 269 | 4 | 64 | 10 | 1 | 6 | 24.6   | 5.6       | 5.7        |
| 175    | 355.5 | 289 | 4 | 10 | 294 | 5 | 39 | 12 | 1 | 6 | 49.6   | 5.8       | 5.9        |
| 200    | 380.5 | 314 | 4 | 10 | 319 | 5 | 64 | 12 | 1 | 6 | 74.6   | 6.1       | 6.2        |
| 250    | 430.5 | 364 | 5 | 12 | 369 | 6 | 64 | 14 | 2 | 8 | 124.6  | 6.5       | 6.6        |
| 300    | 480.5 | 414 | 6 | 14 | 419 | 7 | 64 | 16 | 2 | 8 | 174.6  | 6.9       | 7.0        |

Double Guide Block

| Stroke | L     | A   | B  | C  | D   | E  | F  | G  | H | J  | R     | Mass [kg] |            |
|--------|-------|-----|----|----|-----|----|----|----|---|----|-------|-----------|------------|
|        |       |     |    |    |     |    |    |    |   |    |       | W/o Brake | With Brake |
| 40     | 330.5 | 264 | 3  | 8  | 269 | 4  | 64 | 10 | 0 | 4  | 24.6  | 6.1       | 6.2        |
| 65     | 355.5 | 289 | 4  | 10 | 294 | 5  | 39 | 12 | 0 | 4  | 49.6  | 6.3       | 6.4        |
| 90     | 380.5 | 314 | 4  | 10 | 319 | 5  | 64 | 12 | 0 | 4  | 74.6  | 6.5       | 6.6        |
| 140    | 430.5 | 364 | 5  | 12 | 369 | 6  | 64 | 14 | 1 | 6  | 124.6 | 7.0       | 7.1        |
| 190    | 480.5 | 414 | 6  | 14 | 419 | 7  | 64 | 16 | 1 | 6  | 174.6 | 7.4       | 7.5        |
| 240    | 530.5 | 464 | 7  | 16 | 469 | 8  | 64 | 18 | 2 | 8  | 224.6 | 7.8       | 8.0        |
| 290    | 580.5 | 514 | 8  | 18 | 519 | 9  | 64 | 20 | 2 | 8  | 274.6 | 8.3       | 8.4        |
| 340    | 630.5 | 564 | 9  | 20 | 569 | 10 | 64 | 22 | 3 | 10 | 324.6 | 8.7       | 8.8        |
| 390    | 680.5 | 614 | 10 | 22 | 619 | 11 | 64 | 24 | 3 | 10 | 374.6 | 9.2       | 9.3        |

## 6. Life

The life is assumed under condition of operation with maximum transported mass and maximum acceleration/deceleration, and it is 5,000km (reference).

## 7. Warranty

### 7.1 Warranty Period

One of the following periods, whichever is shorter:

- 18 months after shipment from IAI
- 12 months after delivery to the specified location
- 2,500 hours of operation

### 7.2 Scope of the Warranty

Our products are covered by warranty when all of the following conditions are met. Faulty products covered by warranty will be replaced or repaired free of charge:

- (1) The breakdown or problem in question pertains to our product as delivered by us or our authorized dealer.
- (2) The breakdown or problem in question occurred during the warranty period.
- (3) The breakdown or problem in question occurred while the product was in use for an appropriate purpose under the conditions and environment of use specified in the instruction manual and catalog.
- (4) The breakdown or problem in question was caused by a specification defect or problem, or by a quality issue with our product.

Note that breakdowns due to any of the following reasons are excluded from the scope of warranty:

- [1] Anything other than our product
- [2] Modification or repair performed by a party other than us (unless we have approved such modification or repair)
- [3] Anything that could not be easily predicted with the level of science and technology available at the time of shipment from our company
- [4] A natural disaster, man-made disaster, incident or accident for which we are not liable
- [5] Natural fading of paint or other symptoms of aging
- [6] Wear, depletion or other expected result of use
- [7] Operation noise, vibration or other subjective sensation not affecting function or maintenance

Note that the warranty only covers our product as delivered and that any secondary loss arising from a breakdown of our product is excluded from the scope of warranty.

### 7.3 Honoring the Warranty

As a rule, the product must be brought to us for repair under warranty.

## 7.4 Limited Liability

- (1) We shall assume no liability for any special damage, consequential loss or passive loss such as a loss of expected profit arising from or in connection with our product.
- (2) We shall not be liable for any program or control method created by the customer to operate our product or for the result of such program or control method.

## 7.5 Conditions of Conformance with Applicable Standards/Regulations, Etc., and Applications

- (1) If our product is combined with another product or any system, device, etc., used by the customer, the customer must first check the applicable standards, regulations and/or rules. The customer is also responsible for confirming that such combination with our product conforms to the applicable standards, etc. In such a case we will not be liable for the conformance of our product with the applicable standards, etc.
- (2) Our product is for general industrial use. It is not intended or designed for the applications specified below, which require a high level of safety. Accordingly, as a rule our product cannot be used in these applications. Contact us if you must use our product for any of these applications:
  - 1) Medical equipment used to maintain, control or otherwise affect human life or physical health.
  - 2) Mechanisms and machinery designed for the purpose of moving or transporting people (For vehicle, railway facility or air navigation facility)
  - 3) Important safety parts of machinery (Safety device, etc.)
  - 4) Equipment used to handle cultural assets, art or other irreplaceable items
- (3) Contact us at the earliest opportunity if our product is to be used in any condition or environment that differs from what is specified in the catalog or instruction manual.

## 7.6 Other Items Excluded from Warranty

The price of the product delivered to you does not include expenses associated with programming, the dispatch of engineers, etc. Accordingly, a separate fee will be charged in the following cases even during the warranty period:

- [1] Guidance for installation/adjustment and witnessing of test operation
- [2] Maintenance and inspection
- [3] Technical guidance and education on operating/wiring methods, etc.
- [4] Technical guidance and education on programming and other items related to programs

## Change History

| Revision Date | Description of Revision   |
|---------------|---|
| January 2016  | First edition   |
| April 2016    | Edition 1B <ul style="list-style-type: none"> <li>• Pg. 18      Corrected "Number of Encoder Pulse" to "800"</li> <li>• Pg. 48      Deleted TA8C and TA8R</li> <li>• Pg. 66      Changed the flatness from 0.05mm/m to 0.02mm/m</li> <li>• Pg. 72      Added cautions for mounting the support block</li> <li>• Pg. 73      Added cautions to not fix the perpendicular biplanes of the front plate and the table at the same time</li> <li>• Pg. 81      Deleted description on detaching work of the front cover</li> <li>• Pg.84      Changed belt manufacturer for TA4R and TA7R</li> <li>• Pg. 85, 86    Corrected misdescription (hexagonal socket flat-head bolt -&gt; hexagonal socket button head bolt)</li> </ul> |
| May 2016      | Edition 1C <ul style="list-style-type: none"> <li>• Pg. 89      Added precautions about static electricity during motor replacement</li> </ul>  |
| Jun 2016      | Second edition <ul style="list-style-type: none"> <li>• Added specifications about when high-output setting is ineffective</li> <li>• Pg.83      Changed graphs about duty ratio</li> </ul>   |





## ***IAI Corporation***

Head Office: 577-1 Obane Shimizu-KU Shizuoka City Shizuoka 424-0103, Japan  
TEL +81-54-364-5105 FAX +81-54-364-2589  
website: [www.iai-robot.co.jp/](http://www.iai-robot.co.jp/)

Technical Support available in USA, Europe and China

## ***IAI America, Inc.***

Head Office: 2690 W. 237th Street, Torrance, CA 90505  
TEL (310) 891-6015 FAX (310) 891-0815  
Chicago Office: 110 East State Parkway, Schaumburg, IL 60173  
TEL (847) 908-1400 FAX (847) 908-1399  
Atlanta Office: 1220 Kennestone Circle, Suite 108, Marietta, GA 30066  
TEL (678) 354-9470 FAX (678) 354-9471  
website: [www.intelligentactuator.com](http://www.intelligentactuator.com)

## ***IAI Industrieroboter GmbH***

Ober der Röth 4, D-65824 Schwalbach am Taunus, Germany  
TEL 06196-88950 FAX 06196-889524

## ***IAI (Shanghai) Co., Ltd.***

SHANGHAI JIAHUA BUSINESS CENTER A8-303, 808, Hongqiao Rd. Shanghai 200030, China  
TEL 021-6448-4753 FAX 021-6448-3992  
website: [www.iai-robot.com](http://www.iai-robot.com)

## ***IAI Robot (Thailand) Co., Ltd.***

825, PhairojKijja Tower 12th Floor, Bangna-Trad RD., Bangna, Bangkok 10260, Thailand  
TEL +66-2-361-4458 FAX +66-2-361-4456

The information contained in this document is subject to change without notice for purposes of product improvement.

Copyright © 2016 Jun. IAI Corporation. All rights reserved.