

# Welding Device for Auto Parts

## Application

A mechanism in a welding device for steel pipes to move the welding torch at a constant speed.

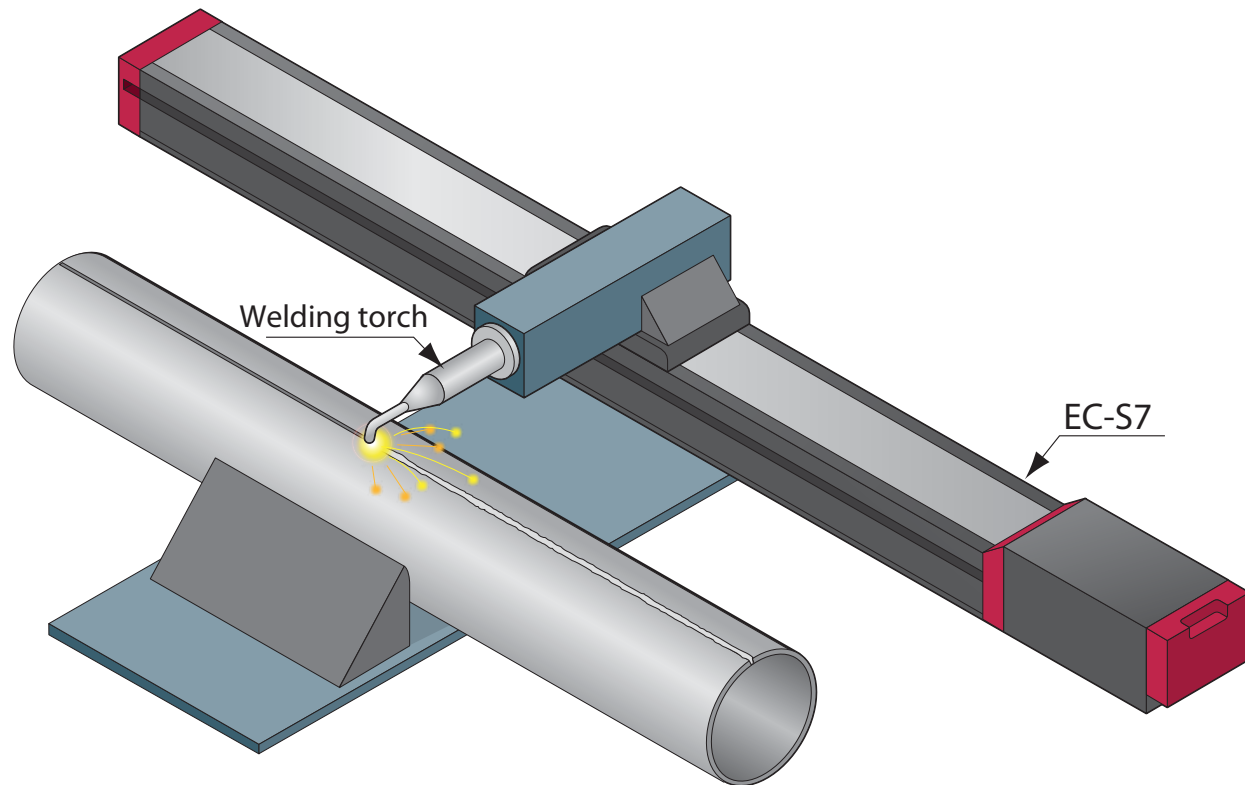

## Description

In the past, this work was done manually, causing uneven quality. By using an **ELECYLINDER**, the moving speed became constant, providing stable quality. In addition, since the speed can easily be changed, fine adjustments are also possible while checking the welding quality. The **ELECYLINDER** provides a low-cost solution and simple operations. Furthermore, fine-adjustments of the welding bead width can be made in a short time thanks to simple speed changing.